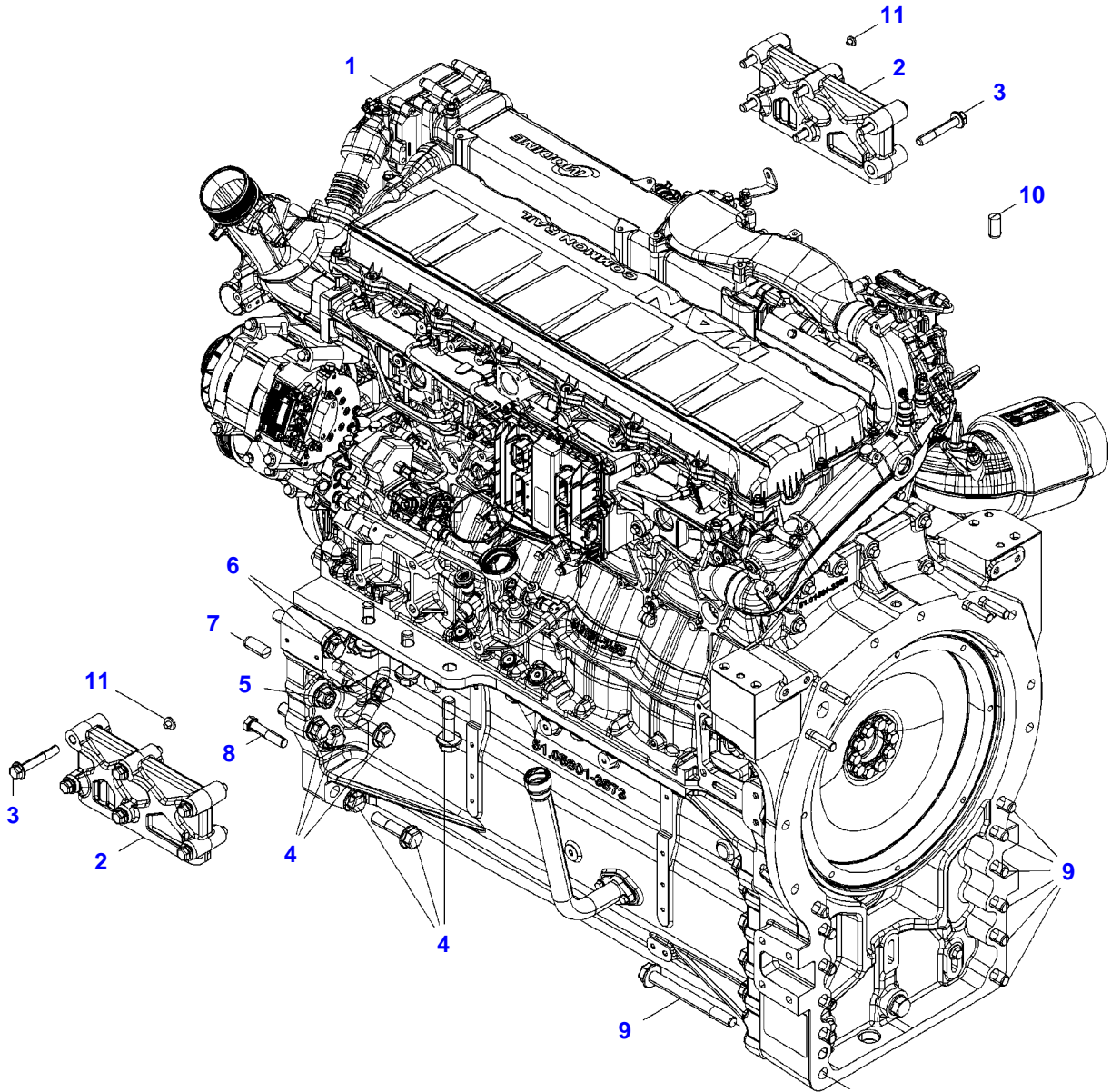

**TABLE OF CONTENT**

<b>Page Number</b>	<b>Page Title</b>	<b>Page Reference</b>
01-000-TOC	ENGINE, FUEL AND EXHAUST SYSTEM	01-000-TOC
02-000-TOC	AXLES	02-000-TOC
03-000-TOC	STEERING SYSTEM	03-000-TOC
04-000-TOC	DRIVE TRAIN SYSTEM	04-000-TOC
05-000-TOC	COMPRESSED AIR SYSTEM	05-000-TOC
06-000-TOC	HYDRAULIC SYSTEM	06-000-TOC
07-000-TOC	ELECTRICAL SYSTEM	07-000-TOC
08-000-TOC	CAB	08-000-TOC
09-000-TOC	AIR CONDITIONING AND HEATING SYSTEM	09-000-TOC
10-000-TOC	CHASSIS	10-000-TOC
11-000-TOC	DECALS	11-000-TOC
12-000-TOC	WHEELS	12-000-TOC
13-000-TOC	IMPLEMENT LIFT SYSTEM FRONT	13-000-TOC
14-000-TOC	IMPLEMENT LIFT SYSTEM REAR	14-000-TOC
15-000-TOC	LINKAGE	15-000-TOC
16-000-TOC	PRECISION FARMING SYSTEMS	16-000-TOC
17-000-TOC	ACCESSORIES	17-000-TOC



12949844-M-1

Item	Part Number	Qty	Description Comments	Technical Specification
1	72620031	1	DIESEL ENGINE	F528 NA
2	72654471	2	TIE PLATE	
3	72620799	12	HEXAGONAL HEAD BOLT	EN1665 M14X2X90-12 VDA10
4	72620800	16	HEXAGONAL HEAD BOLT	EN1665_M20X80-10.9
5	72620791	2	NUT	DIN6923_M20-10
6	72620801	8	HEXAGONAL HEAD BOLT	EN1665_M20X130-10.9
7	72452520	2	CYLINDER PIN	DIN6325-20M6X50
8	72315582	8	HEXAGONAL HEAD BOLT	DIN 931 M16X75 GWA-10.9
9	72620802	12	HEXAGONAL HEAD BOLT	EN1665_M20X190-10.9
10	72420150	3	CYLINDER PIN	DIN 6325 12M6X40
11	72314743	2	LOCKING PLUG	F2

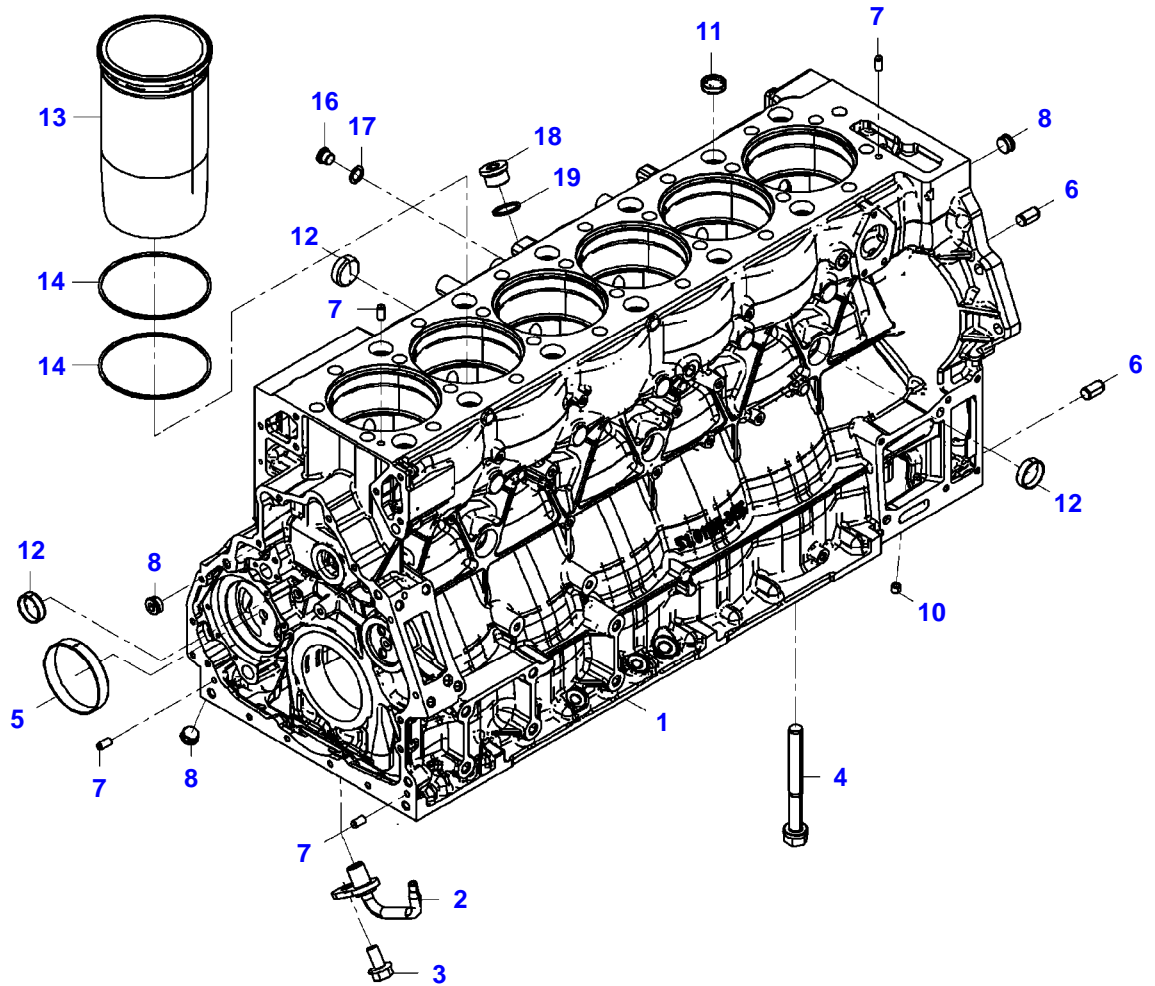

12928707-M-1

## CRANKCASE

Item	Part Number	Qty	Description Comments	Technical Specification
1	72624329	1	CRANKCASE	
2	72624342	6	OIL SPLASH NOZZLE	
3	ACP0410440	6	HEX BOLT, WITH COLLAR	M6X12-10.9
4	72624532	14	HEX BOLT, WITH COLLAR	M18X2X160,5-10.9
5	72624564	1	BEARING BUSH	D=102X18
6	72624289	2	DOWEL	16H8X24-ST50-2K
7	72624290	4	DOWEL	8M6X18
8	72624540	3	PLUG SCREW	M22X1,5X9-5.8
10	72624285	1	SEALING PLUG	10X6,5-C15PB/9SMNPB28K-BK/BK
11	72311428	12	COVER	
12	72624556	6	CAP COVER	A40,3/14,5-X5CRNI1810N
13	72624337	6	CYLINDER LINER	
14	ACP0425080	12	PROFILED CORD SEAL	
16	72624272	1	PLUG SCREW	M16X1,5-ST-M3360-RK9-K
17	72624304	1	SEALING WASHER	16,3X24X1,5-ST/FKM1-80
18	72624273	1	PLUG SCREW	M24X1,5-ST-M3360-RK12-K
19	72624297	1	SEALING WASHER	A26X31-CU

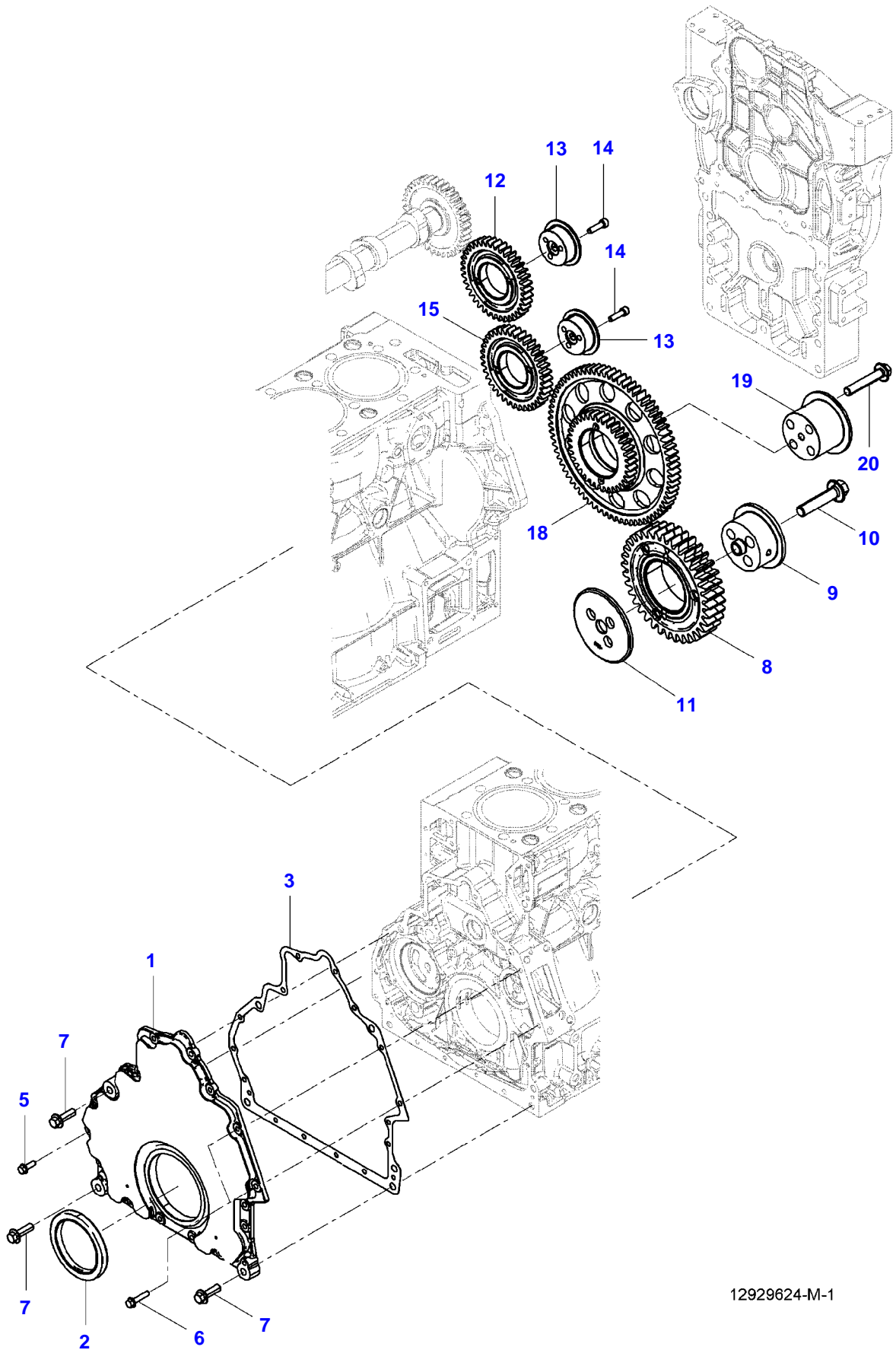

12929624-M-1

## TIMING GEARS AND HOUSING

Item	Part Number	Qty	Description Comments	Technical Specification
1	72624339	1	LID	
2	72624340	1	RADIAL SHAFT LIP SEAL	100X130X12
3	72624345	1	HOUSING GASKET	
5	72624231	12	HEX FLANGE CAPSCREW	M8X25-10.9
6	72624234	2	HEX FLANGE CAPSCREW	M8X40-10.9
7	72624250	3	HEX FLANGE CAPSCREW	M12X40-10.9
8	72629236	1	GEAR,IDLER AIR PRESSER	
9	72629237	1	HUB	
10	72624251	3	HEX FLANGE CAPSCREW	M12X55-10.9
11	72624551	1	THRUST WASHER	
12	72624387	1	GEAR,IDLER	
13	72629228	2	HUB	
14	72624213	6	SOCKET HEAD BOLT	M8X30-10.9
15	72624386	1	GEAR,IDLER	
18	72624385	1	GEAR,IDLER	
19	72629229	1	HUB	
20	72624253	4	HEX FLANGE CAPSCREW	M14X80-10.9

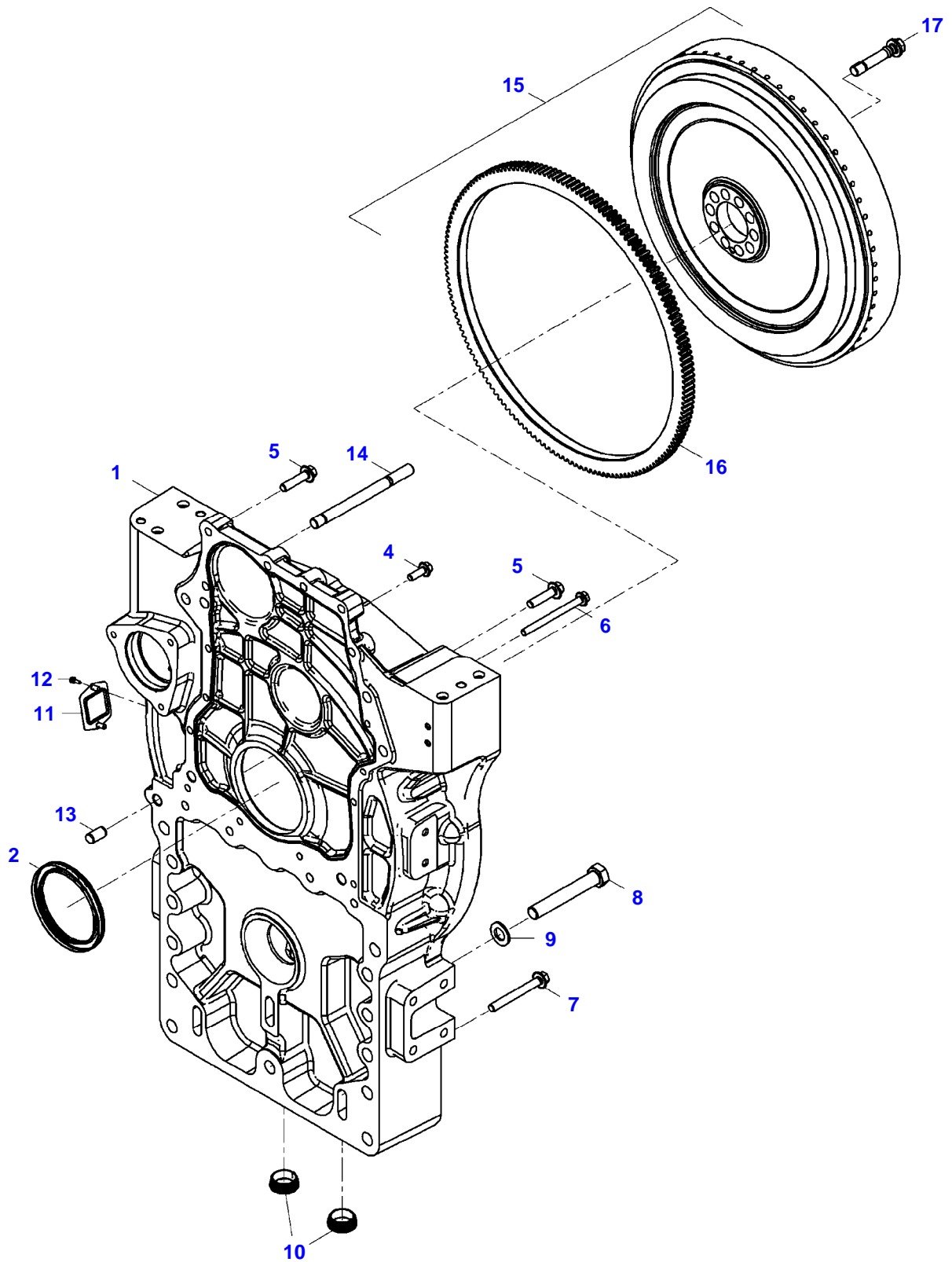

12929934-M-1



## FLYWHEEL AND HOUSING

Item	Part Number	Qty	Description Comments	Technical Specification
1	72625910	1	FLYWHEEL HOUSING	
2	72624341	1	RADIAL SHAFT LIP SEAL	115X140X12LD-ACM/PTFE
4	72624256	9	HEX FLANGE CAPSCREW	M10X30-12.9
5	72624258	10	HEX FLANGE CAPSCREW	M12X50-12.9
6	72624247	1	HEX FLANGE CAPSCREW	M10X120-10.9
7	72624259	2	HEX FLANGE CAPSCREW	M12X100-12.9
8	72624205	1	HEXAGONAL HEAD BOLT	M20X130-10.9
9	72624281	1	WASHER	20X37X3-200HV
10	72314695	2	LOCKING PLUG	
11	ACP0353880	1	BLANK FLANGE	
12	72624230	2	HEX FLANGE CAPSCREW	M8X20-10.9
13	72624289	1	DOWEL	16H8X24-ST50-2K
14	72624262	4	STUD BOLT	M16X1,5X180-12.9-ZNPHR3F
15	72627885	1	FLYWHEEL INCLUDES ITEMS 16	
16	72624355	1	STARTER RING	
17	72624533	10	HEX BOLT, WITH COLLAR	M16X1,5X81-12.9-ZNPHRF

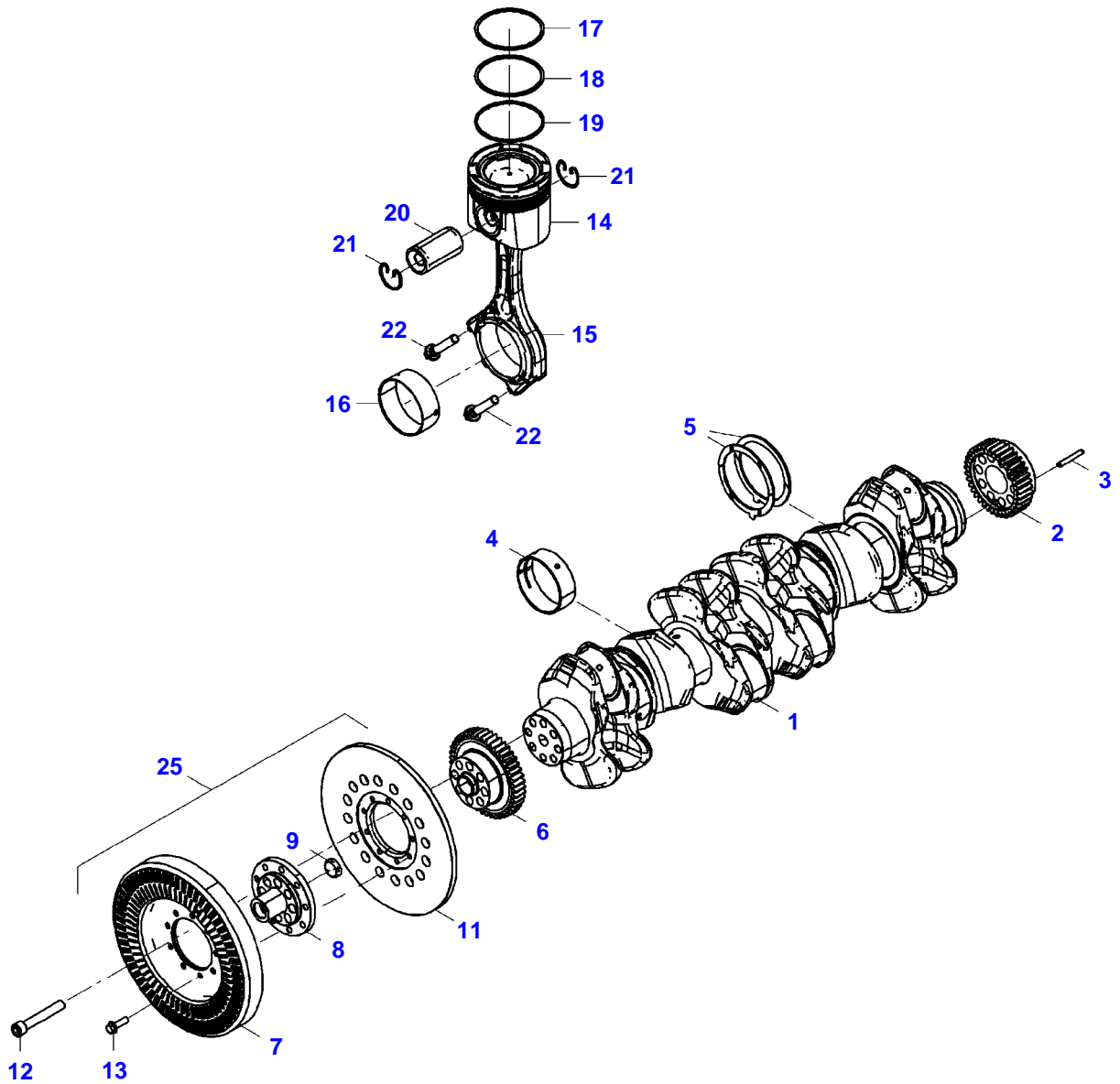

12930450-M-1

## CRANKSHAFT AND PISTONS

Item	Part Number	Qty	Description Comments	Technical Specification
1	ACP0353530	1	CRANKSHAFT	
2	72624350	1	CRANKSHAFT GEAR INCLUDES ITEMS 3	
3	72624291	1	SPIRAL PIN	8X60-ST
4	72624330	7	MAIN BEARING	
5	72624336	2	THRUST WASHER	
6	72624349	1	CRANKSHAFT GEAR	
7	72654401	1	VIBRATION DAMPER	
8	72624353	1	HUB INCLUDES ITEMS 9,10	
9	72624557	1	CAP COVER	A34,2/10-X5CRNI1810N
11	72624352	1	MASS BALANCER	
12	72624212	8	SOCKET HEAD BOLT	M16X1,5X100-10.9
13	72624223	9	HEX FLANGE CAPSCREW	M10X35-8.8
14	ACP0427070	6	PISTON	
15	72627504	6	PISTON ROD	340X115X43
16	72624357	6	CONROD BEARING	D=95X36
17	72624363	1	TRAP.SECTION RG.	D=126X3,5
18	72624365	1	CHAMFER PIST.RG.	D=126X2,5
19	72624364	1	U/MKME-CHAMF.RG.	D=126X3,5
20	72624362	1	PISTON PIN	
21	72624553	2	SNAPRING	52X2-FDST
22	72624545	2	HEXAGON FLANGE BOLT	M13X1,5X66-11.9
25	72629212	1	VIBRATION DAMPER INCLUDES ITEMS 7-11,13	ASM.

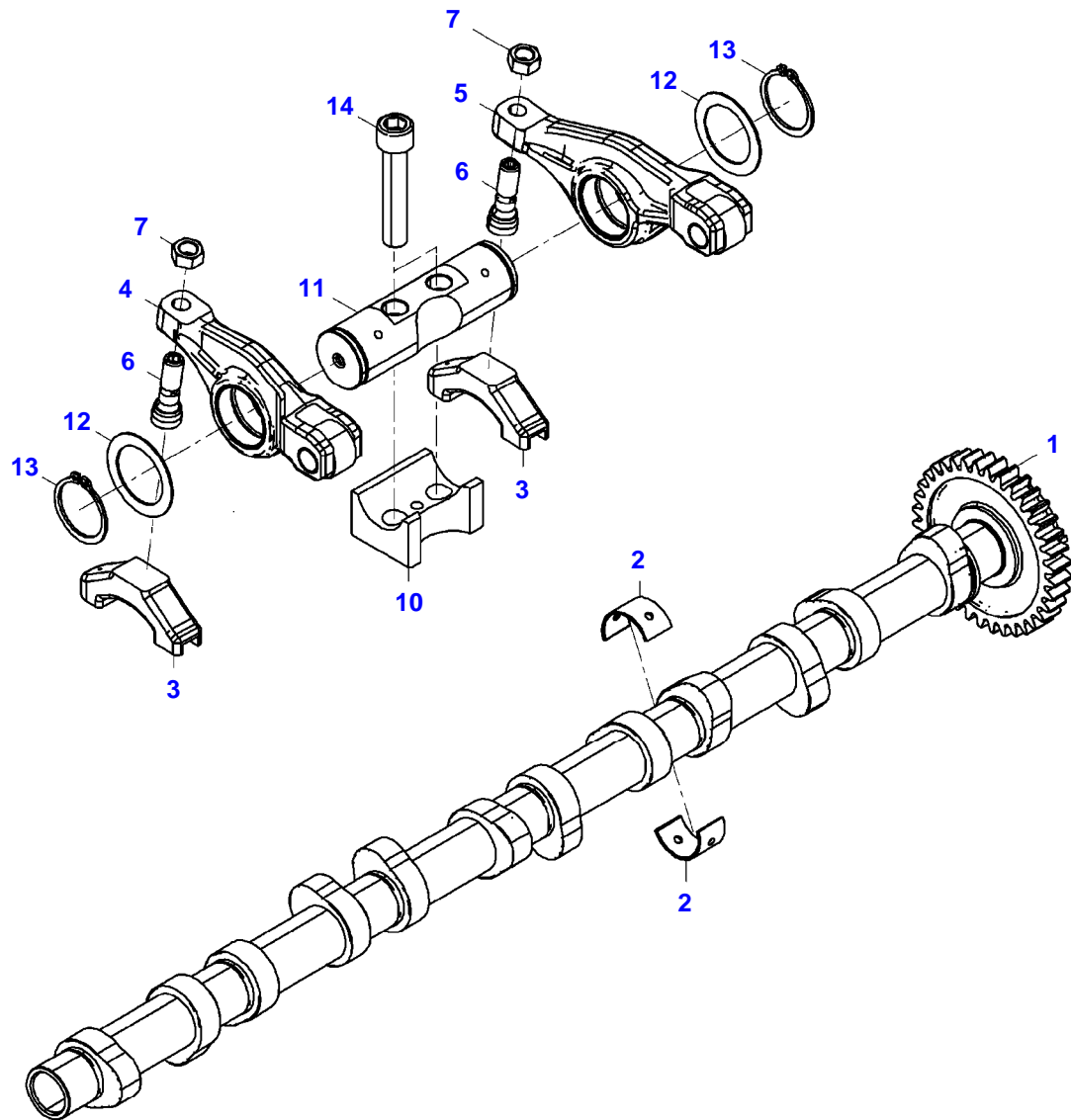

12931704-M-1

## CAMSHAFT AND VALVE

Item	Part Number	Qty	Description Comments	Technical Specification
1	72624383	1	CAMSHAFT	
2	72624384	14	CAMSHAFT BUSHING	D=45X26
3	72624377	12	VALVE BRIDGE	
4	72624378	1	ROCKER ARM	
5	72624379	1	ROCKER ARM	
6	72624382	2	ADJUSTING SCREW	
7	72313252	2	NUT	
10	72629239	1	BEARING SUPPORT	
11	72624381	1	ROCKER SHAFT ASM	
12	72624547	2	SHIM RING	32X45D12X1-DIN1544
13	72624292	2	LOCK WASHER	32X1,50-ZNPHR5F
14	72624215	2	SOCKET HEAD BOLT	M12X60-10.9

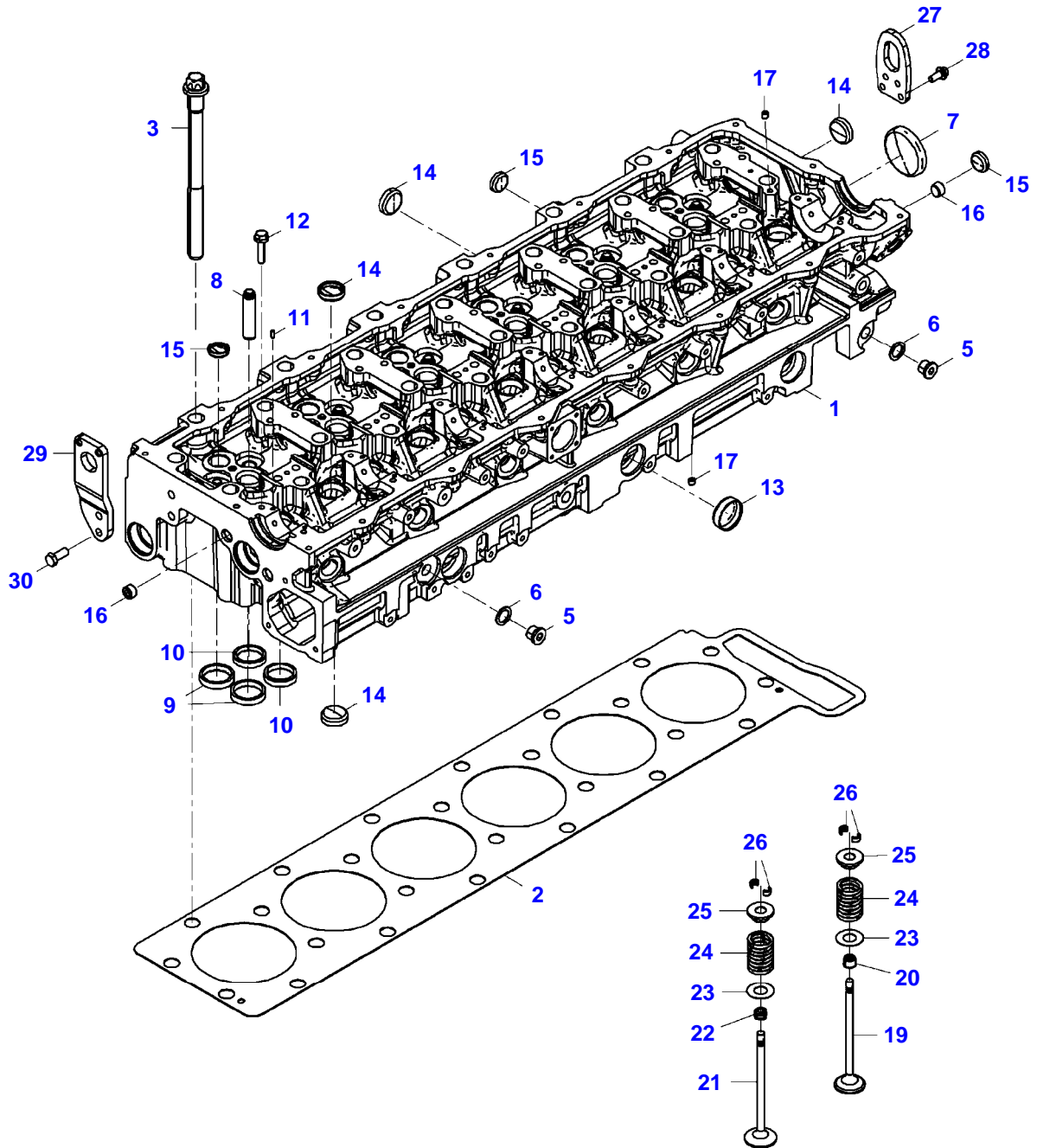

12932888-M-1

## CYLINDER HEAD AND VALVES

Item	Part Number	Qty	Description Comments	Technical Specification
1	72627883	1	CYLINDER HEAD	70HZ
2	72624371	1	CYLINDER HEAD GASKET	
3	72630163	26	HEXAGON FLANGE BOLT	M18X2X246
5	72624272	3	PLUG SCREW	M16X1,5-ST-M3360-RK9-K
6	72624304	3	SEALING WASHER	16,3X24X1,5-ST/FKM1-80
7	72624558	1	CAP COVER	A63,1/12,5-X5CRNI1810N
8	72624367	24	VALVE GUIDE	
9	72624369	12	VALVE SEAT RING INLET	
10	72627821	12	VALVE SEAT RING OUTLET	
11	72624287	14	DOWEL	4H8X10-ST50-2K
12	72624217	14	HEX FLANGE CAPSCREW	M8X35-8.8
13	72311424	3	COVER	
14	72311428	38	COVER	
15	72311429	15	COVER	
16	72624541	4	PLUG SCREW	M16X1,5-ST-M3360-RK8-K
17	72417088	2	SEALING PLUG	
19	72629225	12	EXHAUST VALVE	
20	72624390	12	VALVE STEM SEAL	
21	72624372	12	INLET VALVE	
22	72624390	12	VALVE STEM SEAL	
23	72624548	24	SHIM	16,5X34X0,5-C67S+OT
24	72624374	24	VALVE SPRING	
25	72624375	24	VALVE SPRING RETAINER	
26	72624376	48	VALVE SPRING KEY	
27	72624494	2	HOOK	
28	72624249	4	HEX FLANGE CAPSCREW	M12X30-10.9
29	72624495	1	SUSPENSION EYE	
30	72624209	2	HEXAGONAL HEAD BOLT	M12X30SK-10.9

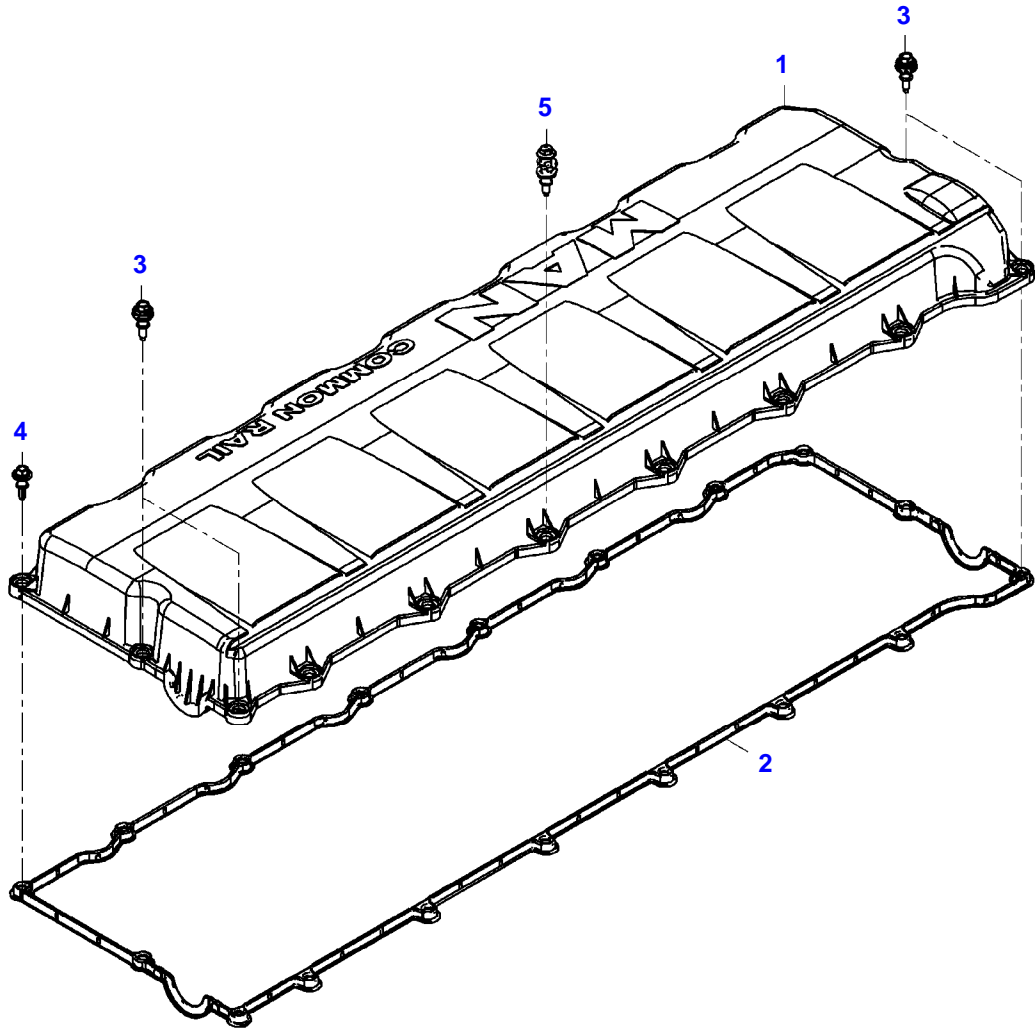

12933215-M-1



**VALVE COVER**

<b>Item</b>	<b>Part Number</b>	<b>Qty</b>	<b>Description Comments</b>
1	72624370	1	CYLINDER HEAD COVER INCLUDES ITEMS 2-5
2	ACP0153600	1	CYLINDER HEAD COVER SEAL
3	72624570	4	INSULATING MATERIAL
4	72624571	8	BUSHING
5	72624546	6	SCREW

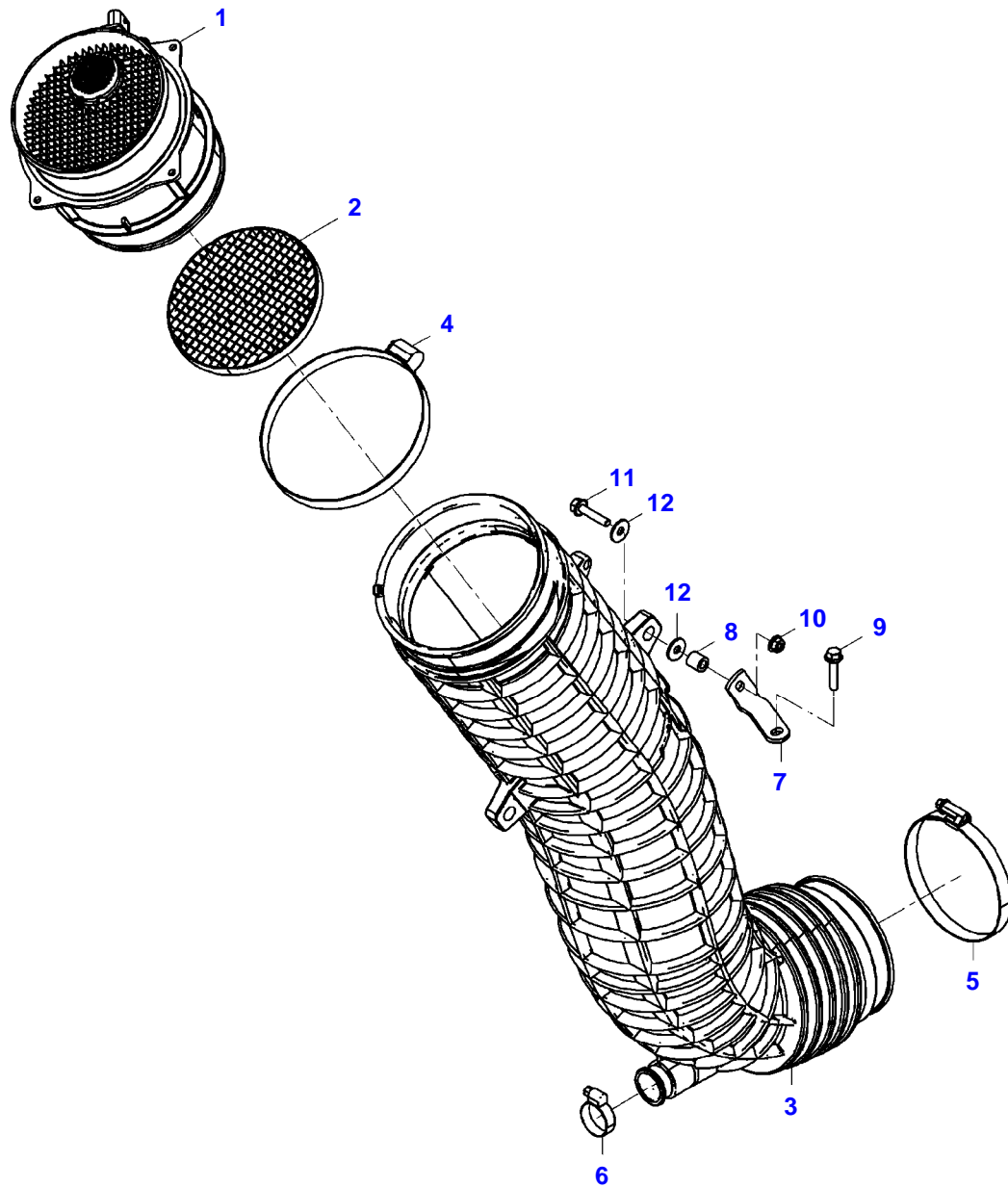

12933230-M-1

Item	Part Number	Qty	Description Comments	Technical Specification
1	72620060	1	SENSOR	
2	72623875	1	MESH PANEL	
3	72654311	1	AIR INTAKE HOSE	
4	72311175	1	HOSE CLIP	
5	72311173	1	HOSE CLIP	
6	72373531	1	HOSE CLIP	
7	72624458	1	HOLDER	
8	72623872	1	BUSHING	
9	72624226	1	HEX FLANGE CAPSCREW	M6X20-10.9
10	72313266	1	NUT	DIN 934 M6-8A3L
11	72315633	1	HEXAGONAL HEAD BOLT	DIN 933 M6X25-8.8A3L
12	72311822	2	DISC	DIN9021-6,4-140HV-A3L

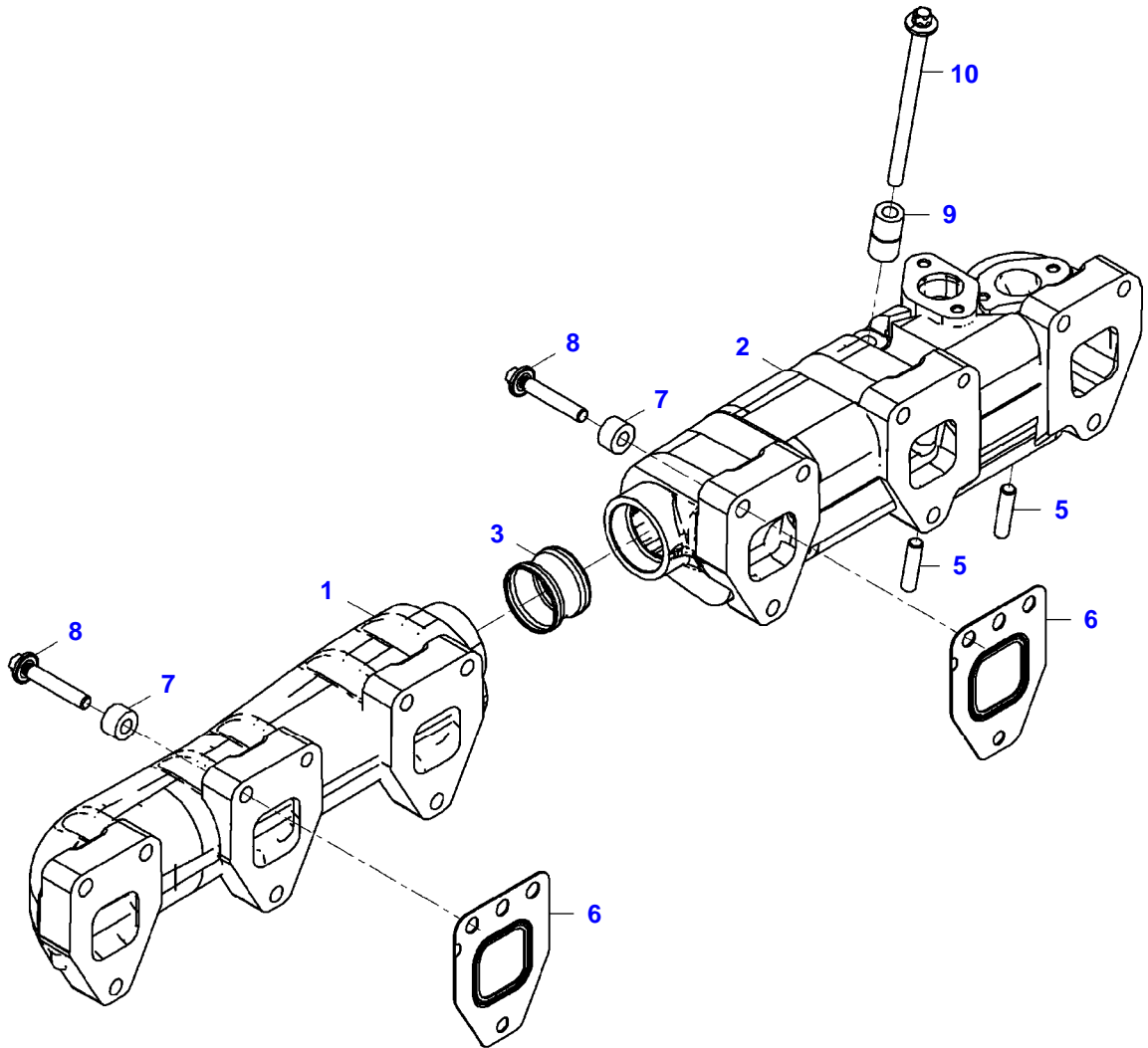

12933457-M-1

## EXHAUST MANIFOLD

Item	Part Number	Qty	Description Comments	Technical Specification
1	72624440	1	EXHAUST ELBOW	
2	72627944	1	EXHAUST ELBOW	
3	72624442	1	CONNECTING PIECE	
5	72624538	2	STUD BOLT	M10X30-SD
6	72624452	6	GASKET	
7	ACP0353750	18	BUSHING	10,5X22X13
8	72315395	18	WASHER HEAD BOLT	
9	72624563	1	BUSHING	10,5X20X37-21CRMOV57V
10	72624544	1	HEXAGON FLANGE BOLT	M10X145-1.4980-E14-SD

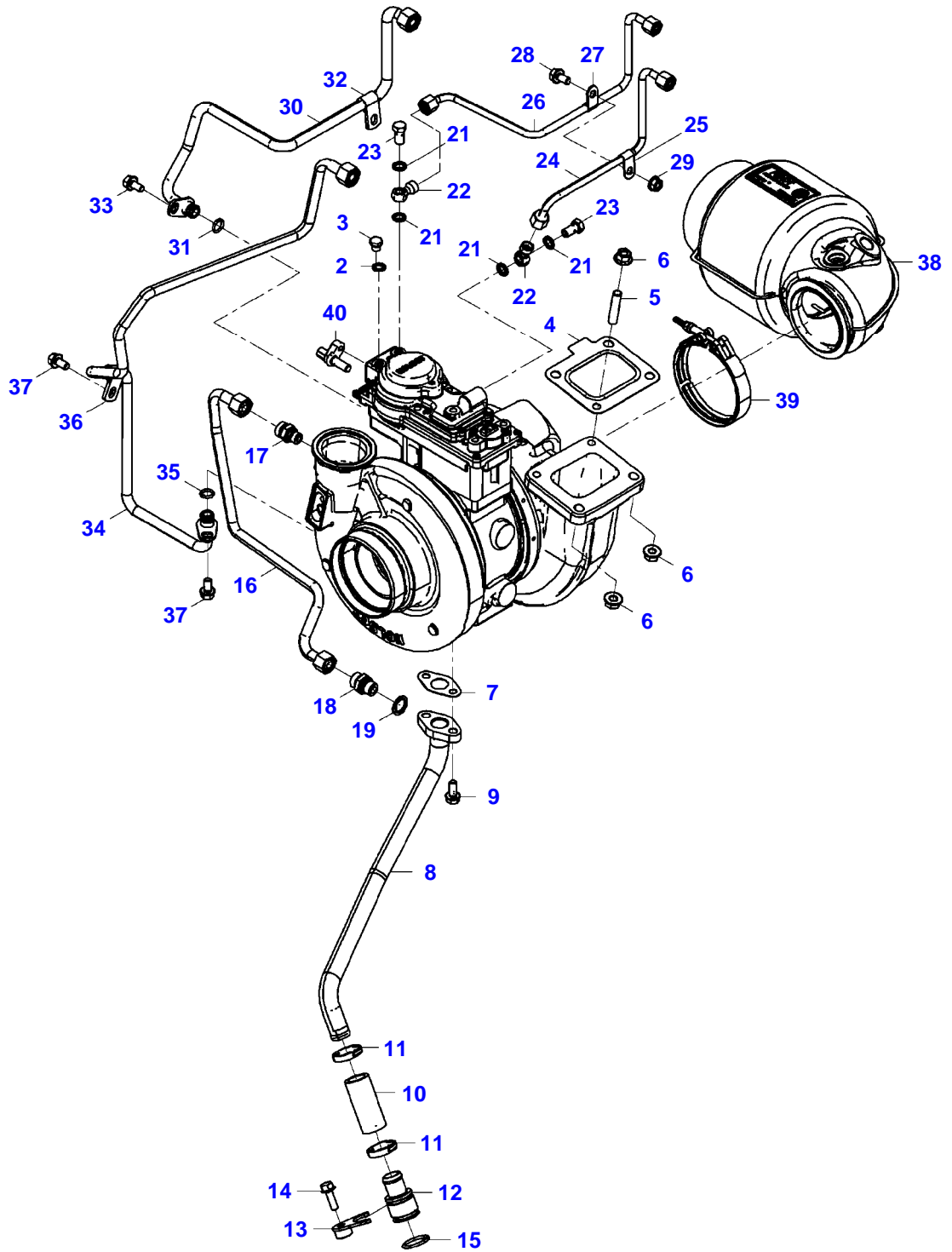

12933506-M-1

Item	Part Number	Qty	Description Comments	Technical Specification
1	72624455	1	EXHAUST TURBOCHARGER INCLUDES ITEMS 20	
2	72624301	1	SEALING WASHER	10,3X16X1,5-ST/FKM1-80
3	72608291	1	SCREW	
4	72624453	1	GASKET	
5	72624539	1	STUD BOLT	M10X35-SD
6	72624276	3	SHOULDER HEX NUT	M10-GA-C3J
7	72624454	1	GASKET	
8	72624402	1	OIL RETURN LINE	
9	72624230	2	HEX FLANGE CAPSCREW	M8X20-10.9
10	72312632	1	HOSE	
11	72624590	2	HOSE CLIP	29,9-33,1
12	72624601	1	HOSE BARB	22/33F8X30-11SMNPB30-P3K
13	72624328	1	HOLDER	
14	72624231	1	HEX FLANGE CAPSCREW	M8X25-10.9
15	72624300	1	O-RING SEAL	28X3B-FPM1-80-GN
16	72624401	1	OIL PRESSURE LINE	
17	72624602	1	SOCKET	
18	72624321	1	THREADED SOCKET	L12A-M-ST
19	72624304	1	SEALING WASHER	16,3X24X1,5-ST/FKM1-80
21	72624301	4	SEALING WASHER	10,3X16X1,5-ST/FKM1-80
22	72624594	2	BANJO UNION	D10,1/M14X1,5
23	72627849	2	BANJO BOLT	
24	72624415	1	COOLANT LINE INCLUDES ITEMS 25	
25	72624585	1	TUBE CLAMP	A8X16X28-9-UST37-2
26	72624416	1	COOLANT LINE INCLUDES ITEMS 27	
27	72624585	1	TUBE CLAMP	A8X16X28-9-UST37-2
28	72624229	1	HEX FLANGE CAPSCREW	M8X16-10.9
29	72624275	1	SHOULDER HEX NUT	M8-8SC-8-SW13
30	72624417	1	COOLANT LINE INCLUDES ITEMS 31,32 UP TO ENGINE S/N 52249811644978	
	ACP0427160	1	COOLANT LINE INCLUDES ITEMS 31,32 FROM ENGINE S/N 52249812075002	
31	ACP0353400	1	SEALING WASHER	12,42X1,78N-FKM2-70
32	72624584	1	TUBE CLAMP	B12,1X20X33-9X13-UST37-2
33	72624229	1	HEX FLANGE CAPSCREW	M8X16-10.9
34	72624422	1	COOLANT LINE INCLUDES ITEMS 35,36 UP TO ENGINE S/N 52249811644978	
	ACP0427170	1	COOLANT LINE INCLUDES ITEMS 35,36 FROM ENGINE S/N 52249812075002	
35	ACP0353400	1	SEALING WASHER	12,42X1,78N-FKM2-70
36	72624584	1	TUBE CLAMP	B12,1X20X33-9X13-UST37-2
37	72624229	2	HEX FLANGE CAPSCREW	M8X16-10.9
38	72624489	1	EXHAUST PIPE	
39	72624591	1	PROFILE CLIP	
40	72624517	1	ENGINE SPEED SENSOR B277	





Item	Part Number	Qty	Description Comments	Technical Specification
			<b>UP TO ENGINE S/N 52245781864573</b>	
1	72627911	1	EGR-MODULE INCLUDES ITEMS 14-23	
2	72624242	8	HEX FLANGE CAPSCREW	M10X45-10.9
3	72624447	1	EXHAUST PIPE	
4	72624450	1	GASKET	
5	72624231	4	HEX FLANGE CAPSCREW	M8X25-10.9
6	72624443	1	HEAT SHIELD	
7	72624279	1	WASHER	8X16X1,6-200HV
8	72624208	1	HEXAGONAL HEAD BOLT	M8X20-8.8-C3J
9	72624280	1	WASHER	10X20X2-200HV
10	72624206	1	HEXAGONAL HEAD BOLT	M10X16-8.8
11	72624446	1	EXHAUST PIPE	
12	ACP0405500	1	EXHAUST PIPE	
13	72624535	8	SOCKET HEAD BOLT	M8X20-GA-C3J
14	72624444	1	HOUSING	
15	72624662	4	CHECK VALVE	
16	72455491	7	HEXAGONAL HEAD BOLT	
17	72624663	1	HEX FLANGE CAPSCREW	M8X45-10.9
18	72629238	2	HEX FLANGE CAPSCREW	
19	72624451	1	SEALING WASHER	
20	72624445	1	SPACER PLATE	
21	72627913	1	AIR STRANGLER	
22	72624666	1	GASKET	143X136X0,29
23	72624667	6	HEXAGON FLANGE BOLT	M8X50-1.7709-E12-GA
24	72624605	1	HOSE COUPLER	
25	72624302	1	SEALING WASHER	12,3X18X1,5-ST/FKM1-80
26	72624457	1	CHARGE AIR ELBOW	
27	72624238	1	HEX FLANGE CAPSCREW	M8X110-10.9
28	72624236	1	HEX FLANGE CAPSCREW	M8X80-10.9
29	72624240	1	HEX FLANGE CAPSCREW	M8X150-10.9
31	72624269	1	PLUG SCREW	M20X1,5-ST-A3C
32	72624305	1	SEALING WASHER	20,3X28X1,5-ST/FKM1-80
33	72629234	1	PLUG SCREW	
34	72624302	1	SEALING WASHER	12,3X18X1,5-ST/FKM1-80
35	72624418	1	COOLANT LINE	
36	72624323	1	THREADED SOCKET	L10A-M12X1,5-ST
37	72624302	1	SEALING WASHER	12,3X18X1,5-ST/FKM1-80
38	72624419	1	COOLANT LINE	
39	72310189	1	RING FITTING	
40	72624302	2	SEALING WASHER	12,3X18X1,5-ST/FKM1-80
41	72624325	1	BANJO BOLT	8-M3360-RK5-K
42	72624449	1	PIPE INCLUDES ITEMS 43	
43	72624583	1	TUBE CLAMP	B6,1X16X20,5-7X10-UST37-2
44	72624322	1	THREADED SOCKET	SDS-L6XM10-B
45	72624225	1	HEX FLANGE CAPSCREW	M6X16-10.9
46	72624668	1	SHOULDER HEX NUT	M6-10

Thank you so much for reading.  
Please click the “Buy Now!”  
button below to download the  
complete manual.



After you pay.

You can download the most  
perfect and complete manual in  
the world immediately.

Our support email:

[ebooklibonline@outlook.com](mailto:ebooklibonline@outlook.com)