

<b>Page Number</b>	<b>Page Title</b>	<b>Page Reference</b>
01-000-TOC	ENGINE, FUEL AND EXHAUST SYSTEM	01-000-TOC
02-000-TOC	AXLES	02-000-TOC
03-000-TOC	STEERING SYSTEM	03-000-TOC
04-000-TOC	DRIVE TRAIN SYSTEM	04-000-TOC
05-000-TOC	COMPRESSED AIR SYSTEM	05-000-TOC
06-000-TOC	HYDRAULIC SYSTEM	06-000-TOC
07-000-TOC	ELECTRICAL SYSTEM	07-000-TOC
08-000-TOC	CAB	08-000-TOC
09-000-TOC	AIR CONDITIONING AND HEATING SYSTEM	09-000-TOC
10-000-TOC	CHASSIS	10-000-TOC
11-000-TOC	WHEELS	11-000-TOC
12-000-TOC	IMPLEMENT LIFT SYSTEM FRONT	12-000-TOC
13-000-TOC	IMPLEMENT LIFT SYSTEM REAR	13-000-TOC
14-000-TOC	FRONT/REAR LOADERS	14-000-TOC
15-000-TOC	ACCESSORIES	15-000-TOC

FAVORIT 711 (711/00101-00200 & 01001-08000)  
31887

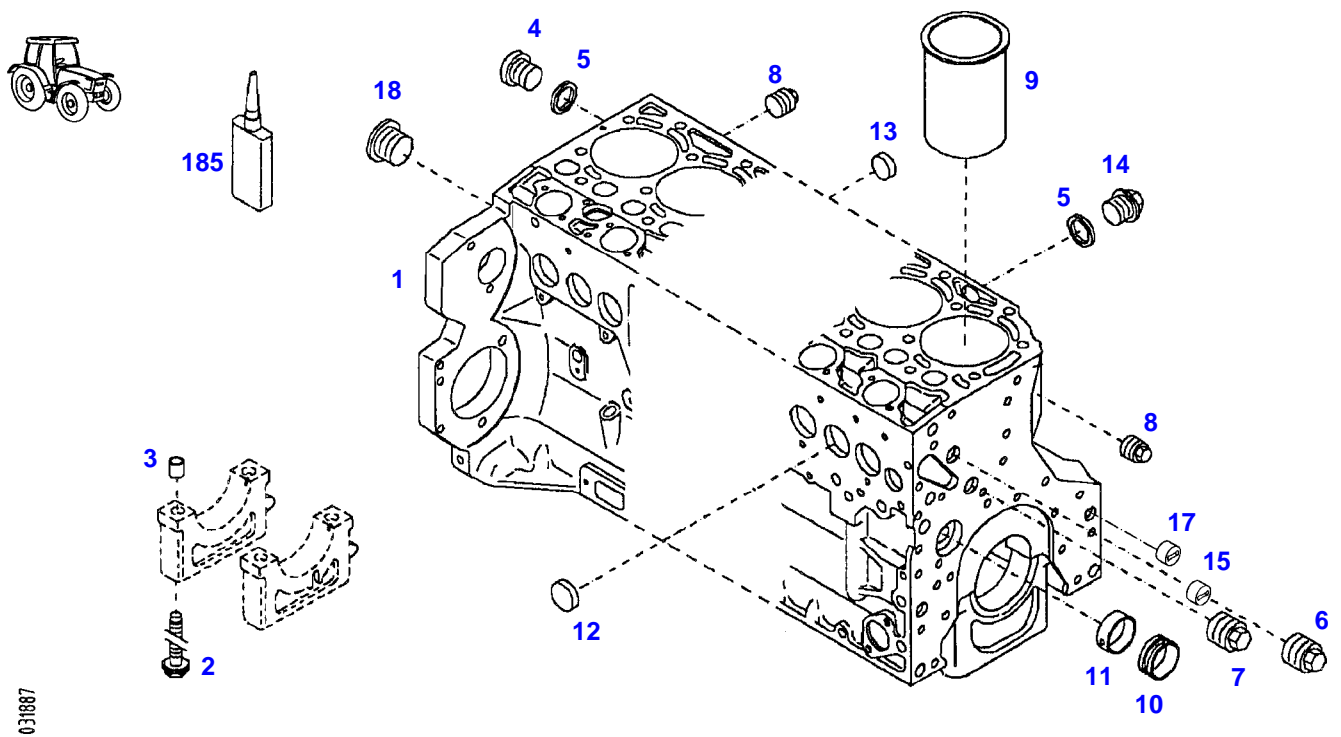

Item	Part Number	Qty	Description Comments	Technical Specification
	72415424	1	ENGINE ENGINE NEW <-- 711/0101 --> 711/0200 <-- 711/1001 --> 711/5182 <-- Z711.201.010.020	BF06M2013
	72604785	1	ENGINE EXCHANGE REMANUFACTURED SHORT BLOCK ENGINE <-- 711/0101 --> 711/0200 <-- 711/1001 --> 711/5182	
	72431127	1	ENGINE ENGINE NEW <-- 711/5183 <-- Z711.201.010.030	BF06M2013
	72604785	1	ENGINE EXCHANGE REMANUFACTURED SHORT BLOCK ENGINE <-- 711/5183	
1	72423957	1	CRANKCASE ><2-15,17,18 ENG.NO. --> 773570 <-- F718.202.210.210 ENG.NO. --> 604302 <> <>	
	72423960	1	THRUST WASHER	
	72429392	1	CRANKCASE ><2-15,17,18 ENG.NO. <-- 773571 <-- F718.202.210.210	
2	72416467	14	HEXAGONAL HEAD BOLT	
3	72344342	14	ADAPTER BUSH	
4	72315438	1	PLUG SCREW	DIN 908 M14X1,5-ST
5	72315095	3	SEALING WASHER	DIN 7603 A14X20-CU
6	72325319	1	PLUG M30X1,5	
7	72325321	1	PLUG	
8	72325322	2	PLUG M14X1,5 ENG.NO. --> 773570	
	72429347	2	SCREW M14X1,5 ENG.NO. <-- 773571	M14X1,5
9	72416468	6	CYLINDER LINER	
10	72416469	6	BEARING BUSHING	
11	72416470	1	BEARING BUSHING	
12	72325325	9	CORE HOLE PLUG	
13	72325326	6	CORE HOLE PLUG	
14	72315799	2	PLUG	DIN 7604 AM14X1,5-A3L
15	72325327	1	GUIDE SLEEVE	
17	72415819	1	GUIDE SLEEVE ENG.NO. <-- 604303	
18	72416465	1	PLUG M22X1,5 ENG.NO. --> 773570	
	72431135	1	LOCKING PLUG M22X1,5 ENG.NO. <-- 773571	
185	72381391	1	THREADLOCKER	LOCTITE 243 10ML

FAVORIT 711 (711/00101-00200 & 01001-08000)  
432327-M-1

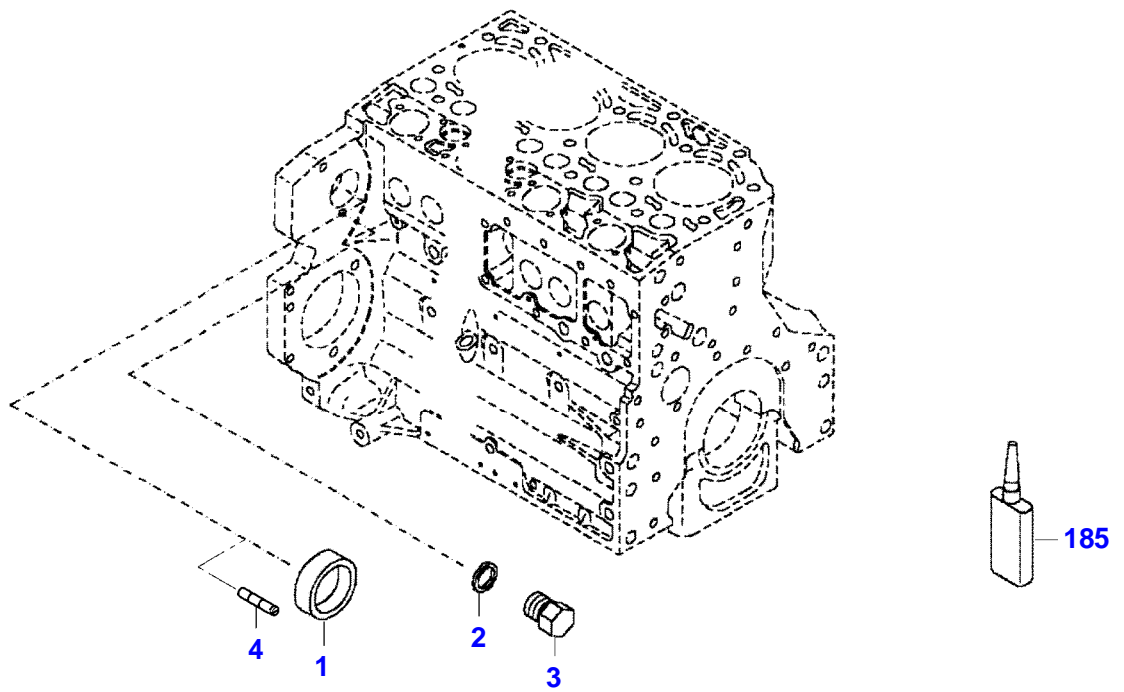

432327-M-1

Item	Part Number	Qty	Description Comments	Technical Specification
<b>BLANKING PARTS</b>				
1	72627515	1	CORE HOLE PLUG	
2	72315088	2	SEALING WASHER	DIN 7603 A10X13,5-CU
3	72323677	2	PLUG	
4	72631860	2	SLUG	
185	72325403	1	SAFE.LOCK AGENT	

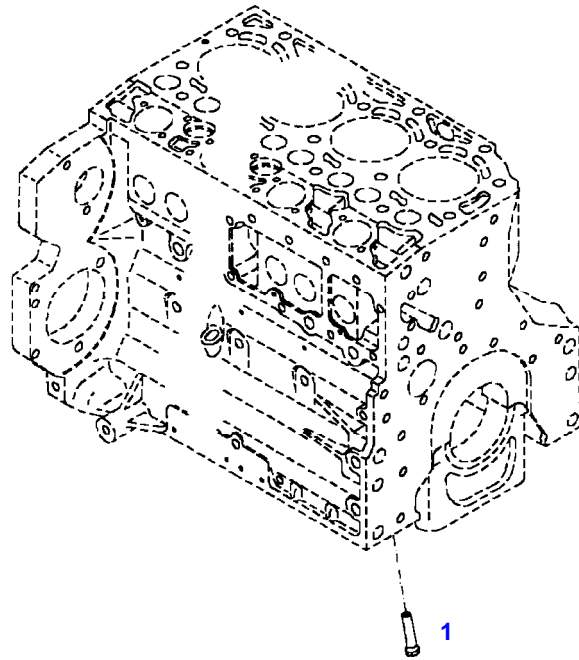

030004

---

Fendt

FAVORIT 711 (711/00101-00200 & 01001-08000)

F711000

CRANKCASE

Page01-0003

---

Item	Part Number	Qty	Description Comments
			PISTON COOL.NOZZLE
1	72415140	6	PISTON COOLING JET

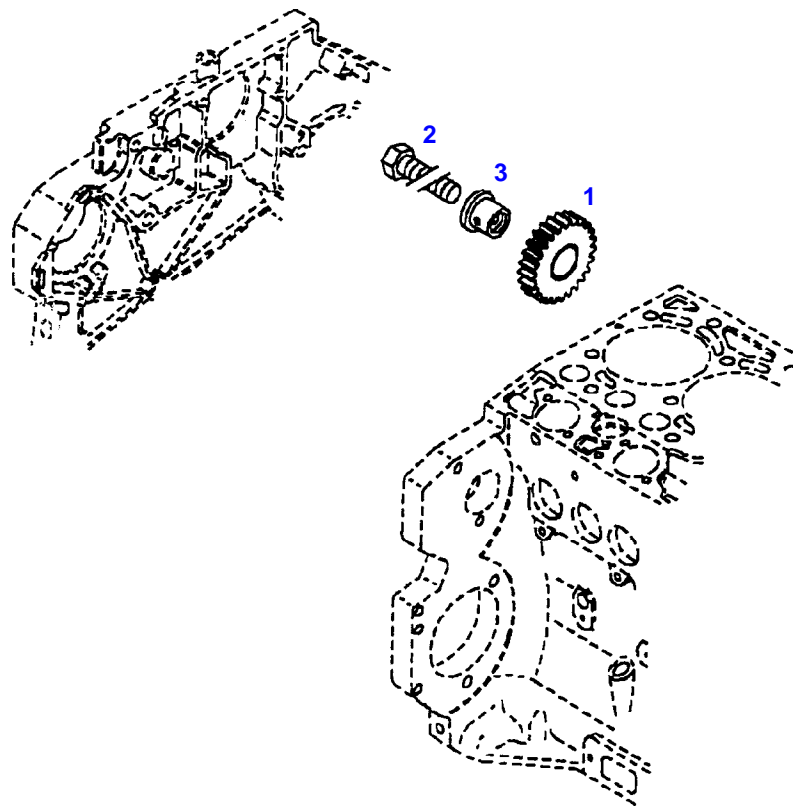

12057



---

Item	Part Number	Qty	Description Comments	Technical Specification
			<b>INTERM. GEAR WHEEL</b>	
1	72325335	1	GEAR WHEEL	
2	72315658	1	HEXAGONAL HEAD BOLT	DIN 933 M8X35-10.9
3	72325336	1	PIVOT	

FAVORIT 711 (711/00101-00200 & 01001-08000)  
40194

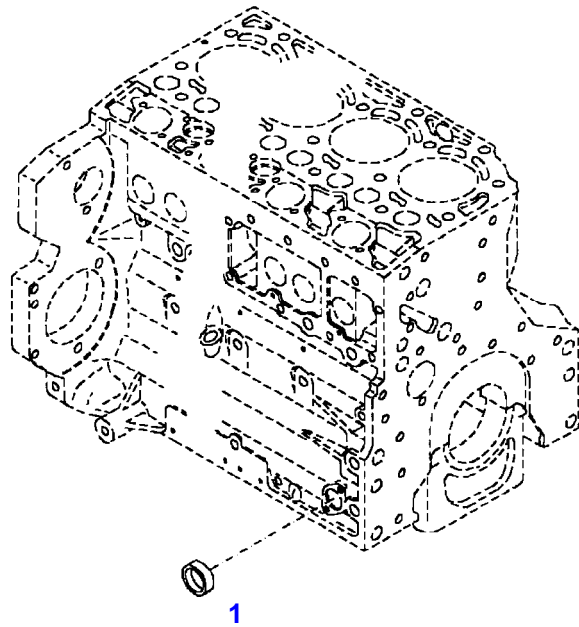

040194

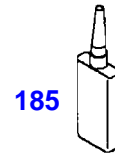

185

Fendt

FAVORIT 711 (711/00101-00200 & 01001-08000)

F711000

CRANKCASE

Page01-0005

Item	Part Number	Qty	Description Comments
			LOCKING PLUG
1	72325326	1	CORE HOLE PLUG
185	72325403	1	SAFE.LOCK AGENT

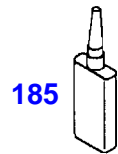
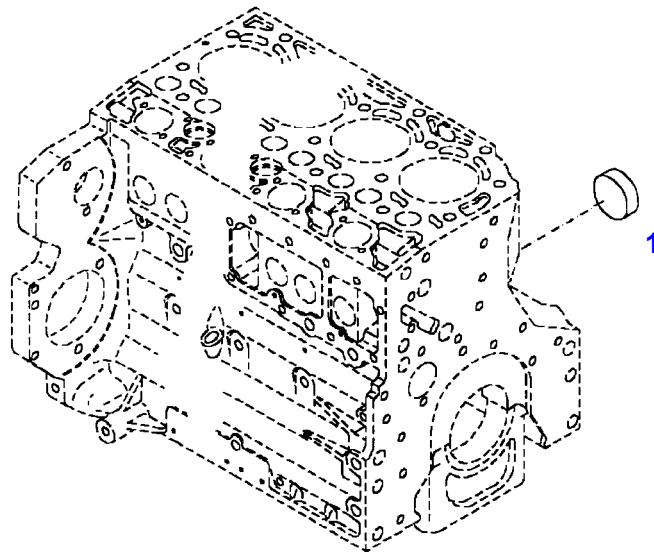

030097

Fendt

FAVORIT 711 (711/00101-00200 & 01001-08000)

F711000

CRANKCASE

Page01-0006

Item	Part Number	Qty	Description Comments
			LOCKING PLUG <-- 711/0101 --> 711/0200 <-- 711/1001 --> 711/5182
1	72325337	1	CORE HOLE PLUG
185	72325403	1	SAFE.LOCK AGENT

FAVORIT 711 (711/00101-00200 & 01001-08000)  
F51551

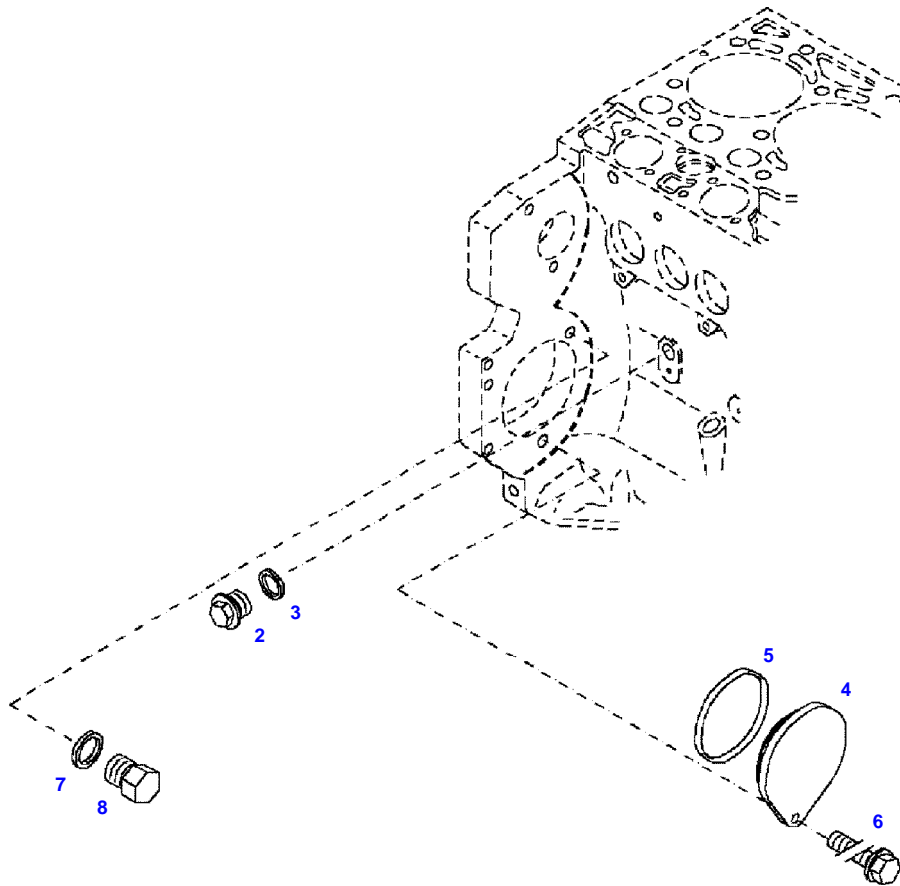

051551



Item	Part Number	Qty	Description Comments	Technical Specification
			<b>BLANKING PARTS</b> <b>ENGINE NUMBER</b> --> 829341	
2	72315799	1	PLUG NOT NEEDED WITH AIR BRAKE	DIN 7604 AM14X1,5-A3L
3	72315094	1	SEALING WASHER NOT NEEDED WITH AIR BRAKE	DIN 7603 A14X18-CU
4	72431648	1	COVER NOT NEEDED WITH AIR BRAKE	
5	72416472	1	SEAL 96X4MM NOT NEEDED WITH AIR BRAKE	
6	72621034	1	HEXAGONAL HEAD BOLT NOT NEEDED WITH AIR BRAKE	M10X20
7	72315088	1	SEALING WASHER	DIN 7603 A10X13,5-CU
8	72323677	1	PLUG	

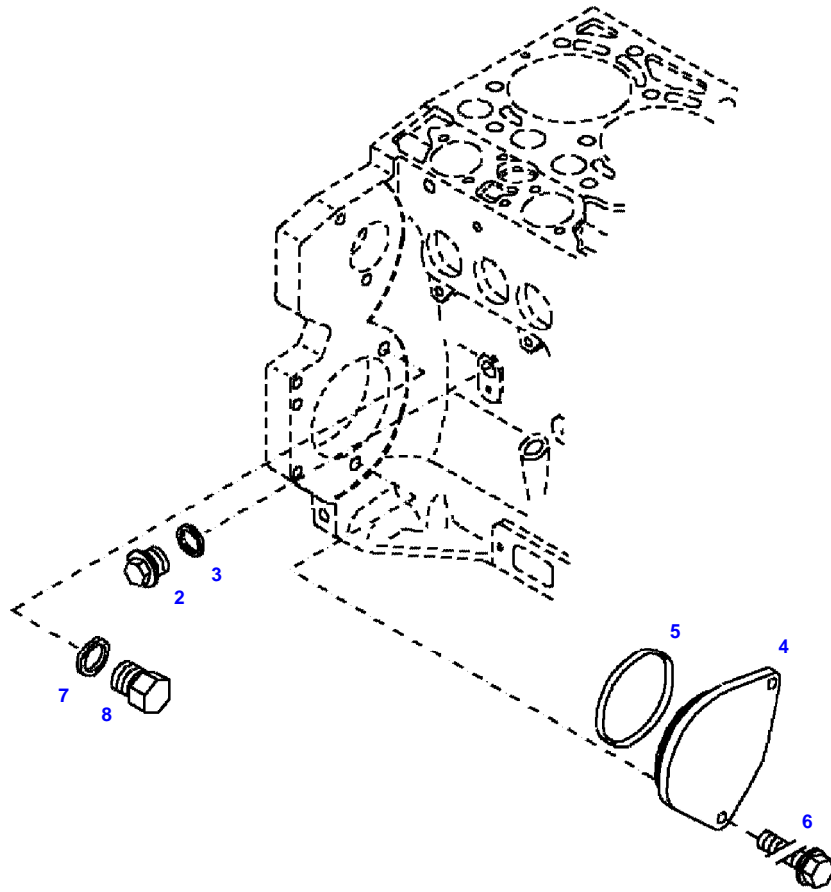

051552





Item	Part Number	Qty	Description Comments	Technical Specification
			<b>BLANKING PARTS ENGINE NUMBER &lt;-- 829342</b>	
2	72315799	1	PLUG NOT NEEDED WITH AIR BRAKE	DIN 7604 AM14X1,5-A3L
3	72315094	1	SEALING WASHER NOT NEEDED WITH AIR BRAKE	DIN 7603 A14X18-CU
4	72431648	1	COVER NOT NEEDED WITH AIR BRAKE	
5	72416472	1	SEAL 96X4MM NOT NEEDED WITH AIR BRAKE	
6	72621034	2	HEXAGONAL HEAD BOLT NOT NEEDED WITH AIR BRAKE	M10X20
7	72315088	1	SEALING WASHER	DIN 7603 A10X13,5-CU
8	72323677	1	PLUG	

FAVORIT 711 (711/00101-00200 & 01001-08000)  
40029

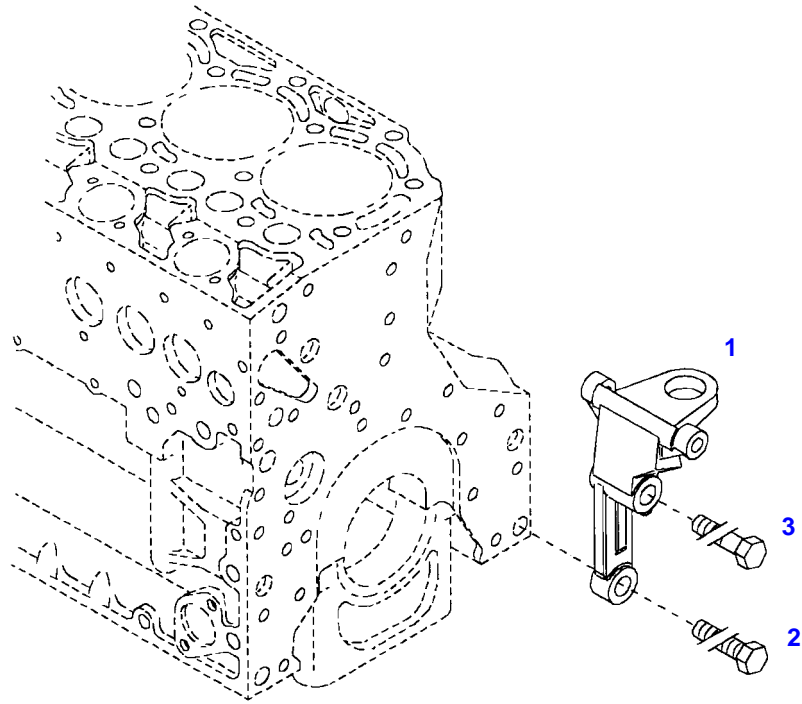

040029

Item	Part Number	Qty	Description Comments	Technical Specification
			<b>LEFT</b>	
1	72428791	1	ENGINE SUSPENSION	
2	72418408	1	HEXAGONAL HEAD BOLT	DIN 933 M16X40 GWA-10.9
3	72374294	1	HEXAGONAL HEAD BOLT	DIN 931-M16X85 GWA-10.9

FAVORIT 711 (711/00101-00200 & 01001-08000)  
40030

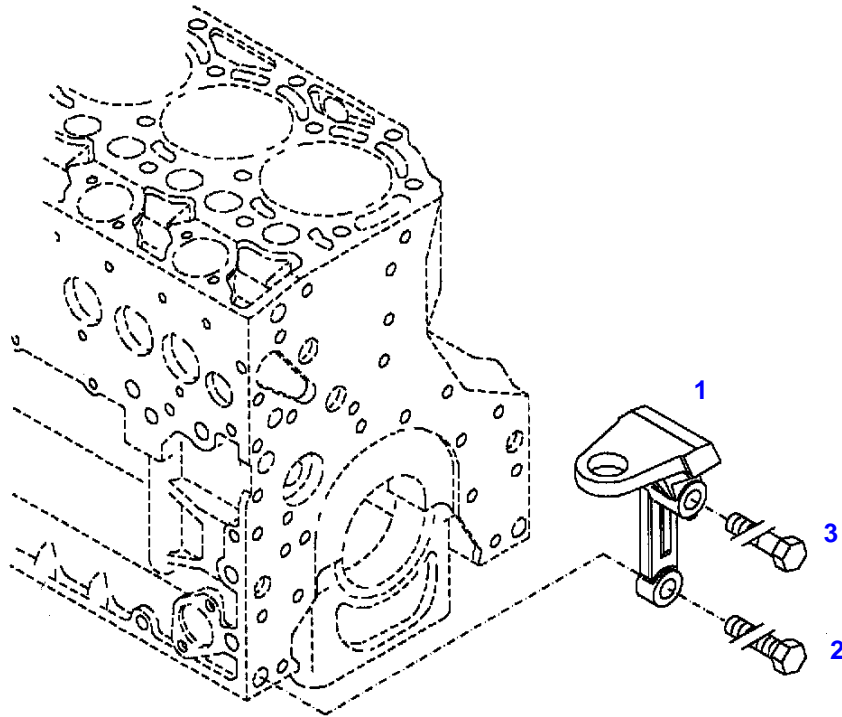

040030

Item	Part Number	Qty	Description Comments	Technical Specification
			<b>RIGHT</b>	
1	72423955	1	ENGINE SUSPENSION	
2	72418408	1	HEXAGONAL HEAD BOLT	DIN 933 M16X40 GWA-10.9
3	72374294	1	HEXAGONAL HEAD BOLT	DIN 931-M16X85 GWA-10.9

FAVORIT 711 (711/00101-00200 & 01001-08000)  
35107

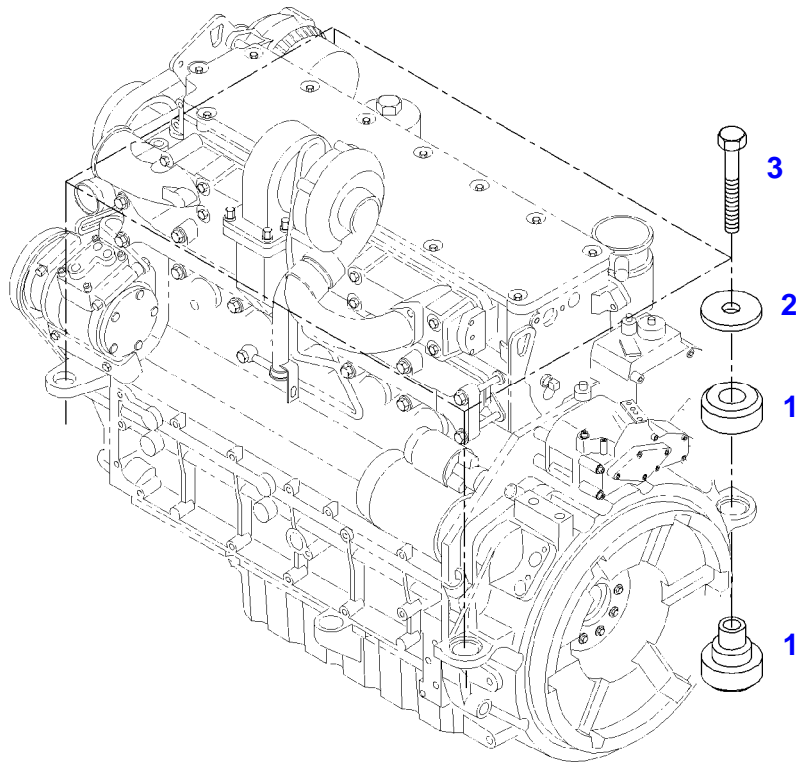

035107

---

Fendt

FAVORIT 711 (711/00101-00200 & 01001-08000)

F711000

ENGINE BEARINGS

Page01-0011

---

Item	Part Number	Qty	Description Comments	Technical Specification
1	72423991	4	ENGINE MOUNT	
2	72318110	4	DISC	
3	72315563	4	HEXAGONAL HEAD BOLT	DIN 931 M12X80-8.8A3L

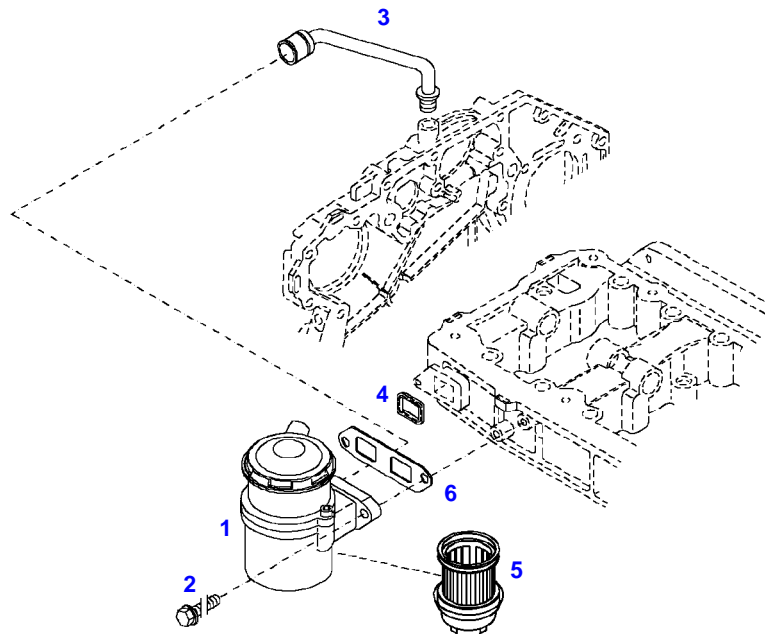

036448



Item	Part Number	Qty	Description Comments	Technical Specification
			<b>ENGINE NUMBER</b> --> 651347	
1	72416476	1	BREATHER ><4,5	
2	72325449	2	HEXAGONAL HEAD BOLT M8X25	M8X25
3	72416477	1	RUBBER-JACKET CORD	
4	72416500	1	MOLDED SEAL ENG.NO. <-- 369828	
5	72416501	1	FILTER ELEMENT	
6	72416502	1	SEAL ENG.NO. --> 369827	

FAVORIT 711 (711/00101-00200 & 01001-08000)  
12566

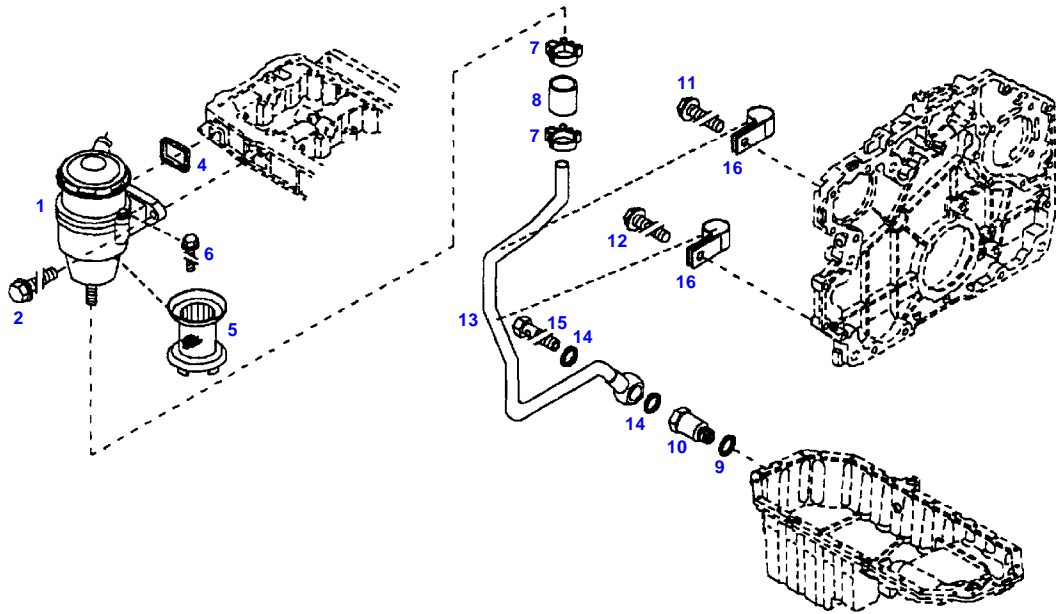

12566

Item	Part Number	Qty	Description Comments	Technical Specification
			<b>ENGINE NUMBER</b> <-- 651348	
1	72425784	1	BREATHER ><4-6 <-- F718.202.210.130	
2	72325449	2	HEXAGONAL HEAD BOLT M8X25	M8X25
4	72416500	1	MOLDED SEAL	
5	72425767	1	FILTER ELEMENT	
6	72425768	2	HEXAGONAL HEAD BOLT M5X20	
7	72325537	2	HOSE CLIP	
8	72425769	1	THIMBLE	
9	72315101	1	SEALING WASHER	DIN 7603 A22X27-CU
10	72425770	1	LOCK VALVE	
11	72325453	1	HEXAGONAL HEAD BOLT M8X50	
12	72325457	1	HEXAGONAL HEAD BOLT M8X40	
13	72425771	1	BREATHER LINE ><14-16	
14	72416578	2	SEALING WASHER	
15	72323517	1	BANJO BOLT	
16	72425772	2	PIPE CLAMP	

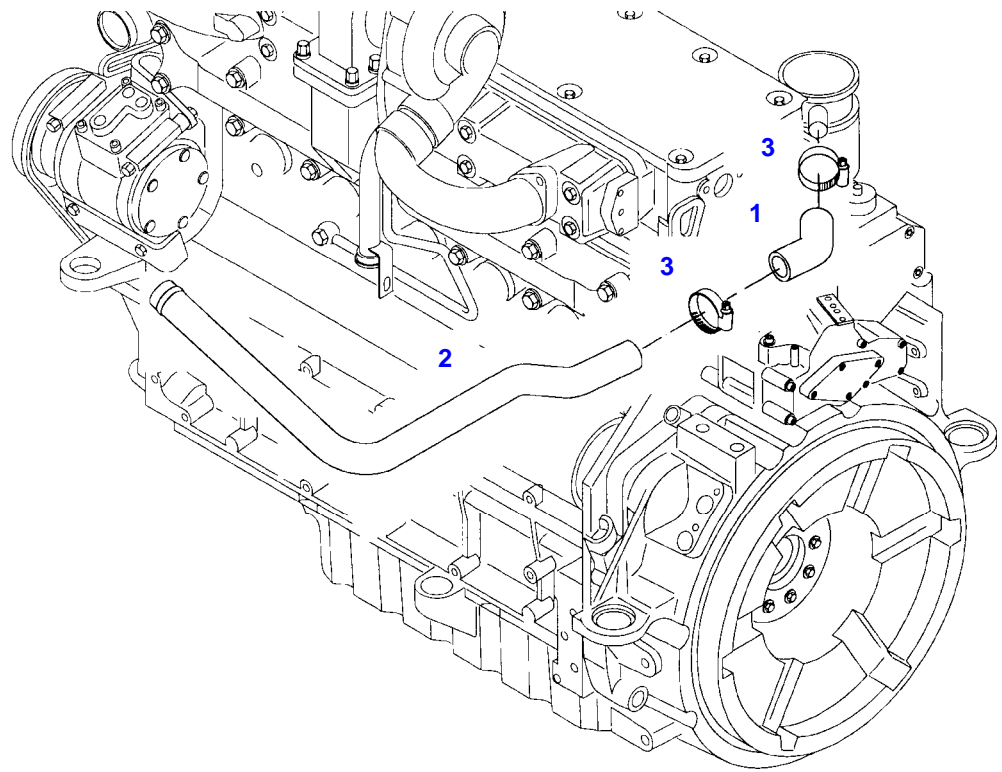

6660E0

---

Fendt

FAVORIT 711 (711/00101-00200 & 01001-08000)

F711000

CRANKCASE BREATHER

Page01-0014

---

Item	Part Number	Qty	Description Comments
			PIPE
1	72318111	1	RUBBER ARCH
2	72318112	1	PIPE
3	72311167	2	HOSE CLIP

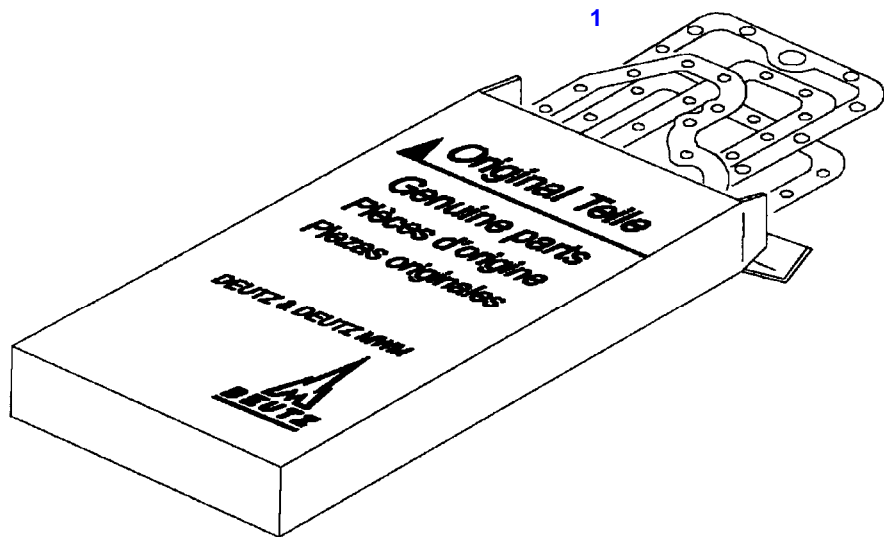

030100

Item	Part Number	Qty	Description Comments
			<b>ENGINE</b>
1	72487669	1	SEAL KIT WITHOUT CYLINDER HEAD GASKET FOR VALVE COVER ALUMINIUM ENG.NO. --> 555824
	72487673	1	SEAL KIT WITHOUT CYLINDER HEAD GASKET FOR VALVE COVER PLASTIC ENG.NO. <-- 555825

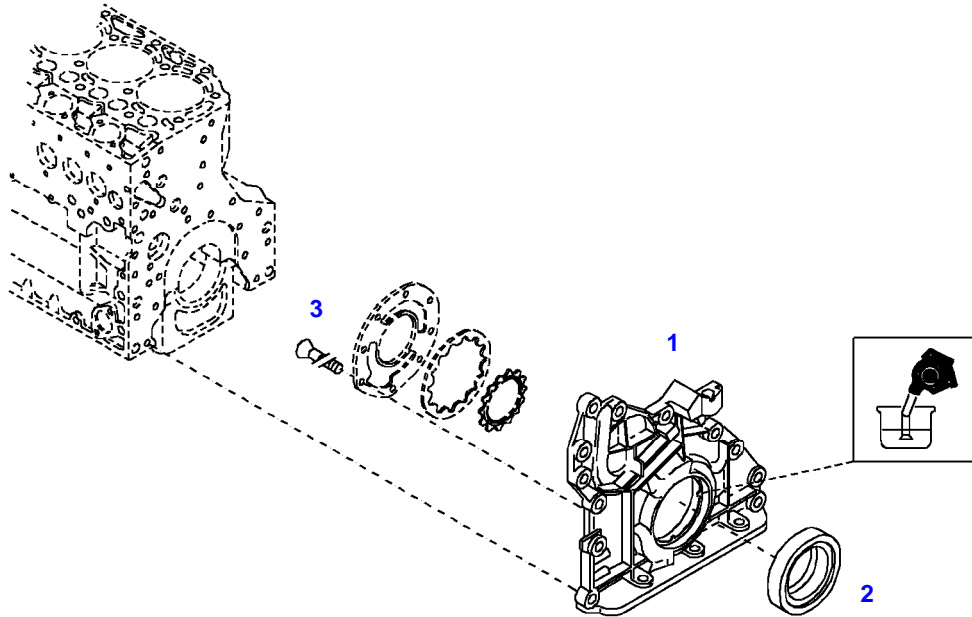

040475



Item	Part Number	Qty	Description Comments
			<b>INTEGRATED OIL PUMP</b>
1	72479485	1	CRANKCASE END COVER INTEGRATED OIL PUMP ><2,3
2	72479487	1	SHAFT SEAL
3	72416228	8	COUNTERSUNK CAPSCREW M8X16

FAVORIT 711 (711/00101-00200 & 01001-08000)  
41308

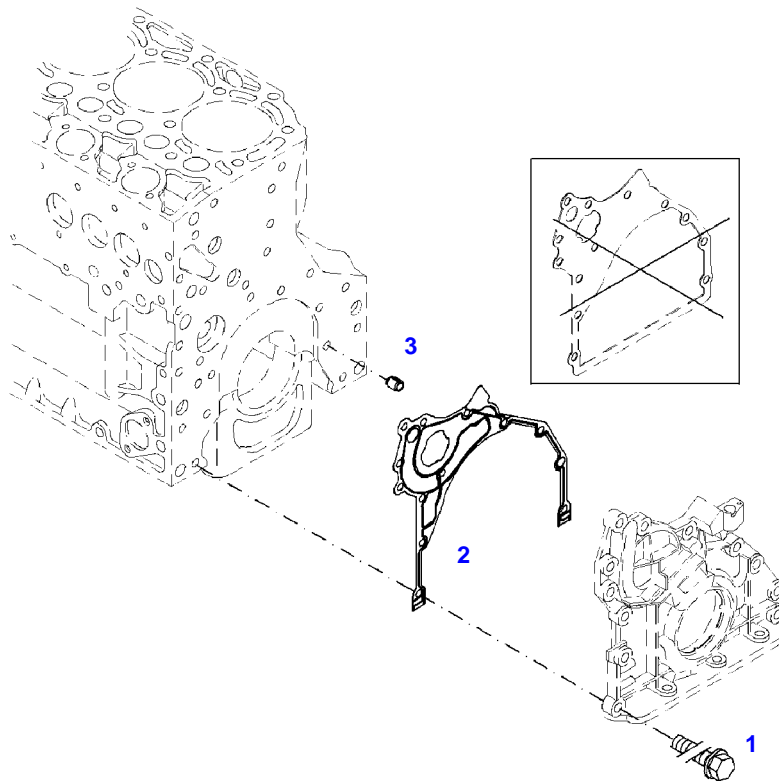

041308

---

Fendt

FAVORIT 711 (711/00101-00200 & 01001-08000)

F711000

FRONT COVER

Page01-0017

---

Item	Part Number	Qty	Description Comments	Technical Specification
<b>FASTENINGS</b>				
1	72605244	10	HEXAGONAL HEAD BOLT M8X35	M8X35
2	72486511	1	SEAL	
3	72325352	1	TENSIONER BUSHING	

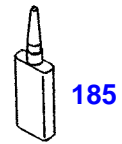
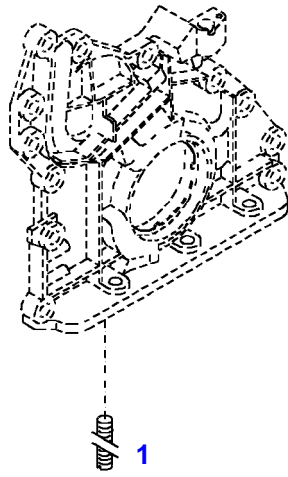

040503

Fendt

FAVORIT 711 (711/00101-00200 & 01001-08000)

F711000

FRONT COVER

Page01-0018

Item	Part Number	Qty	Description Comments
			BLANKING PARTS ENGINE NUMBER <-- 439469 --> 527757
1	72416230	1	THREADED PIN M8X14
185	72325403	1	SAFE.LOCK AGENT

Thank you so much for reading.  
Please click the “Buy Now!”  
button below to download the  
complete manual.



After you pay.

You can download the most  
perfect and complete manual in  
the world immediately.

Our support email:

[ebooklibonline@outlook.com](mailto:ebooklibonline@outlook.com)