

Page Number	Page Title	Page Reference
01-000-TOC	ENGINE, FUEL AND EXHAUST SYSTEM	01-000-TOC
02-000-TOC	AXLES	02-000-TOC
03-000-TOC	STEERING SYSTEM	03-000-TOC
04-000-TOC	DRIVE TRAIN SYSTEM	04-000-TOC
05-000-TOC	COMPRESSED AIR SYSTEM	05-000-TOC
06-000-TOC	HYDRAULIC SYSTEM	06-000-TOC
07-000-TOC	ELECTRICAL SYSTEM	07-000-TOC
08-000-TOC	CAB	08-000-TOC
09-000-TOC	AIR CONDITIONING AND HEATING SYSTEM	09-000-TOC
10-000-TOC	CHASSIS	10-000-TOC
11-000-TOC	WHEELS	11-000-TOC
12-000-TOC	IMPLEMENT LIFT SYSTEM FRONT	12-000-TOC
13-000-TOC	IMPLEMENT LIFT SYSTEM REAR	13-000-TOC
14-000-TOC	ACCESSORIES	14-000-TOC

FENDT 930 (928/00101-99999)
F41530

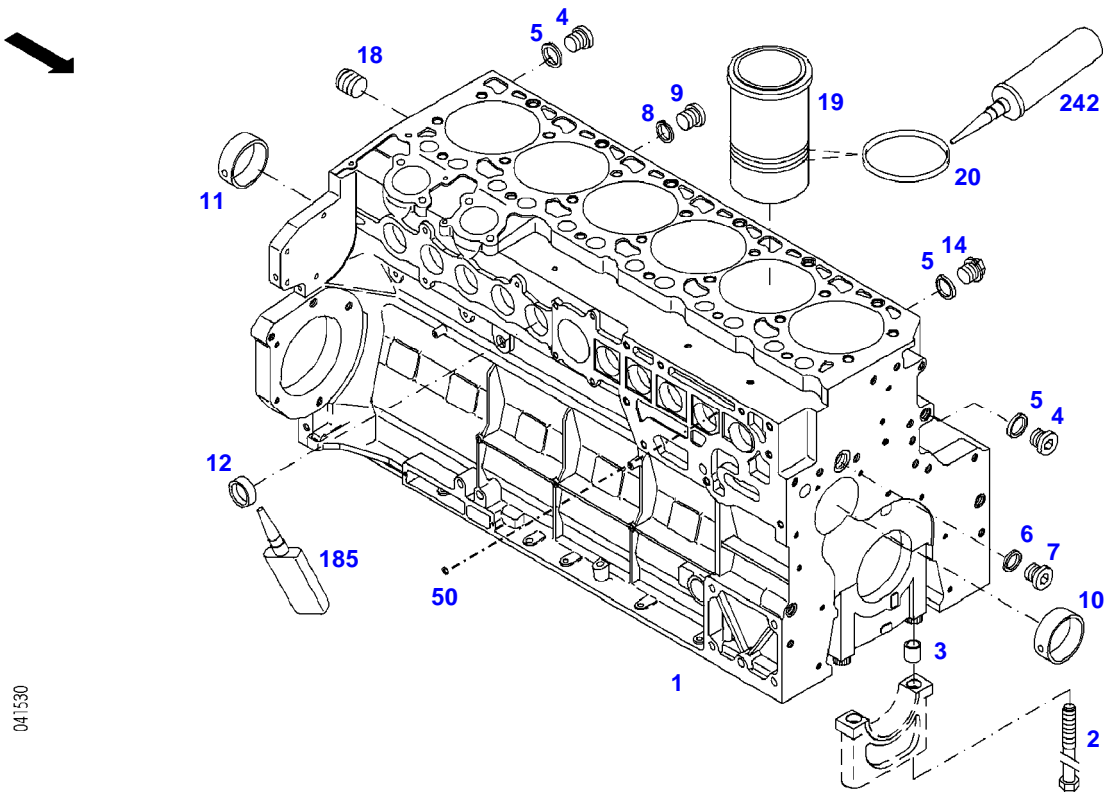

041530

Item	Part Number	Qty	Description Comments	Technical Specification
			<-- 928/4341	
	72487637	1	ENGINE FOR MARKETS WITH EXHAUST REGULATIONS PLEASE ORDER WITH ENGINE NO. ONLY !	TCD2013L064V
	72604351	1	REMANUFACTURED SHORT BLOCK ENGINE FOR MARKETS WITH EXHAUST REGULATIONS	
	72609457		REMANUFACTURED LONG BLOCK ENGINE INCLUDING CYLINDER HEAD	INCLUDING CYLINDER HEAD
	72454880	1	ENGINE FOR MARKETS WITH EXHAUST REGULATIONS PLEASE ORDER WITH ENGINE NO. ONLY !	TCD2013L064V
	72494619	1	REMANUFACTURED ENGINE ENGINE EXCHANGE FOR MARKETS WITHOUT EXHAUST REGULATIONS PLEASE ORDER WITH ENGINE NO. ONLY !	
	72604351	1	REMANUFACTURED SHORT BLOCK ENGINE FOR MARKETS WITHOUT EXHAUST REGULATIONS	
	72609457	1	REMANUFACTURED LONG BLOCK ENGINE INCLUDING CYLINDER HEAD FOR MARKETS WITHOUT EXHAUST REGULATIONS	INCLUDING CYLINDER HEAD
1	72474386	1	CRANKCASE	
2	72451992	14	SCREW	
3	72451993	14	ADAPTER BUSH	
4	72315438	2	PLUG SCREW	DIN 908 M14X1,5-ST
5	72315094	3	SEALING WASHER	DIN 7603 A14X18-CU
6	72315101	1	SEALING WASHER	DIN 7603 A22X27-CU
7	72315442	1	PLUG	DIN 908 M22X1,5-ST
8	72315104	1	SEALING WASHER	DIN 7603 A26X31-CU
9	72373957	1	SCREW	DIN 908-M26X1,5-ST-A3L
10	72451995	6	BEARING BUSHING	
11	72451996	1	BEARING BUSHING	
12	72325325	10	CORE HOLE PLUG	
14	72315799	1	PLUG	DIN 7604 AM14X1,5-A3L
18	72416465	1	PLUG M22X1,5	
19	72451997	6	CYLINDER LINER ><20	
20	72415821	12	SEAL 112X3MM	
50	72614774	X	SEALING PLUG	4X4,5MM
185	72325403	1	SAFE.LOCK AGENT	
242	72325276	1	INSTALLATION AIDS	

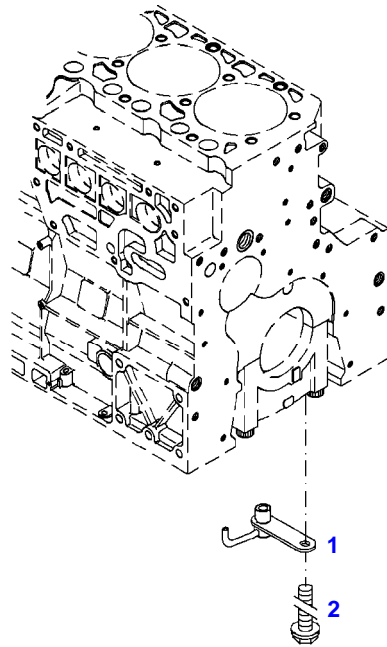

035631

Fendt

FENDT 930 (928/00101-99999)

F928000

CRANKCASE

Page01-0004

Item	Part Number	Qty	Description Comments	Technical Specification
			PISTON COOL.NOZZLE	
1	72451998	6	PISTON COOLING JET	
2	72605244	6	HEXAGONAL HEAD BOLT M8X35	M8X35

FENDT 930 (928/00101-99999)
41038

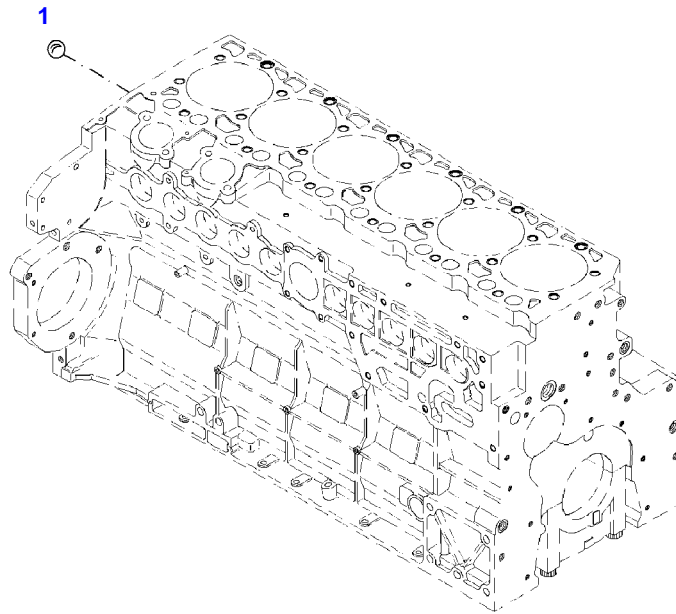

041038

Fendt

FENDT 930 (928/00101-99999)

F928000

CRANKCASE

Page01-0005

Item	Part Number	Qty	Description Comments
			BLANKING PARTS ENGINE NUMBER <-- 10394266 --> 10435249
1	72439920	X	BALL

FENDT 930 (928/00101-99999)
35632

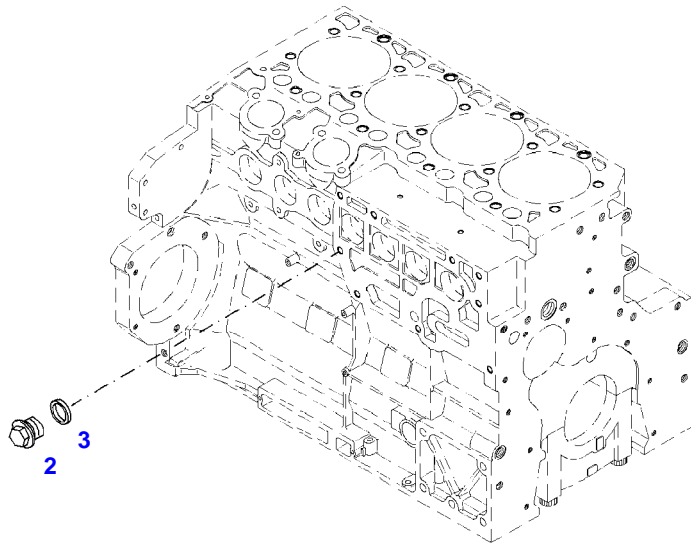

035632

Fendt

FENDT 930 (928/00101-99999)

F928000

CRANKCASE

Page01-0006

Item	Part Number	Qty	Description Comments	Technical Specification
BLANKING PARTS				
2	72315799	1	PLUG	DIN 7604 AM14X1,5-A3L
3	72315094	1	SEALING WASHER	DIN 7603 A14X18-CU

FENDT 930 (928/00101-99999)
41229

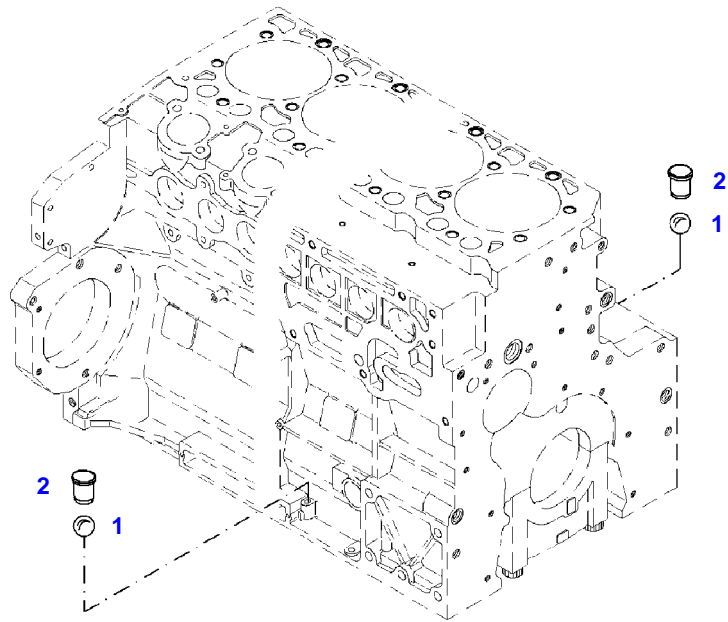

041229

Fendt

FENDT 930 (928/00101-99999)

F928000

CRANKCASE

Page01-0007

Item	Part Number	Qty	Description Comments
			LOCKING PLUG
1	72484231	2	BALL
2	72611452	2	LOCKING PLUG

FENDT 930 (928/00101-99999)
40930

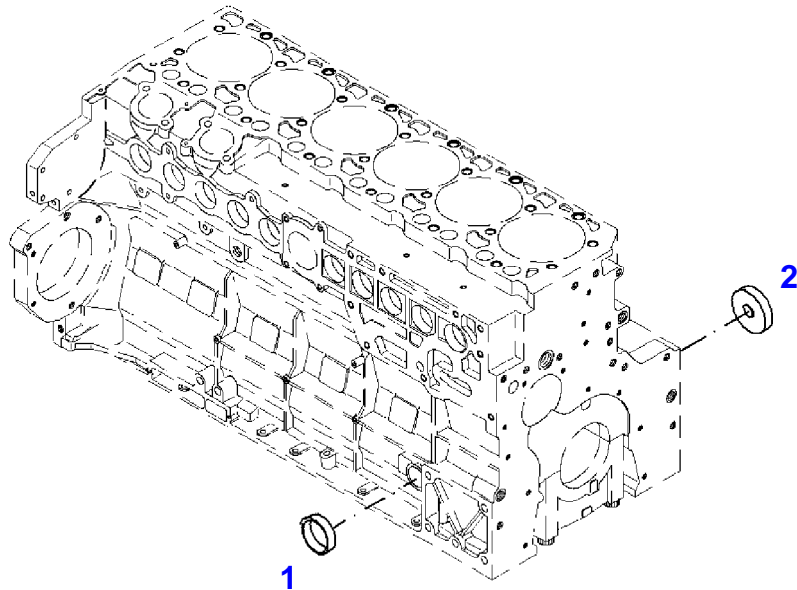

040930

Fendt

FENDT 930 (928/00101-99999)

F928000

CRANKCASE

Page01-0008

Item	Part Number	Qty	Description Comments
------	-------------	-----	-------------------------

BLANKING PARTS

1	72327066	1	COVER
2	72437548	1	COVER

FENDT 930 (928/00101-99999)
40970

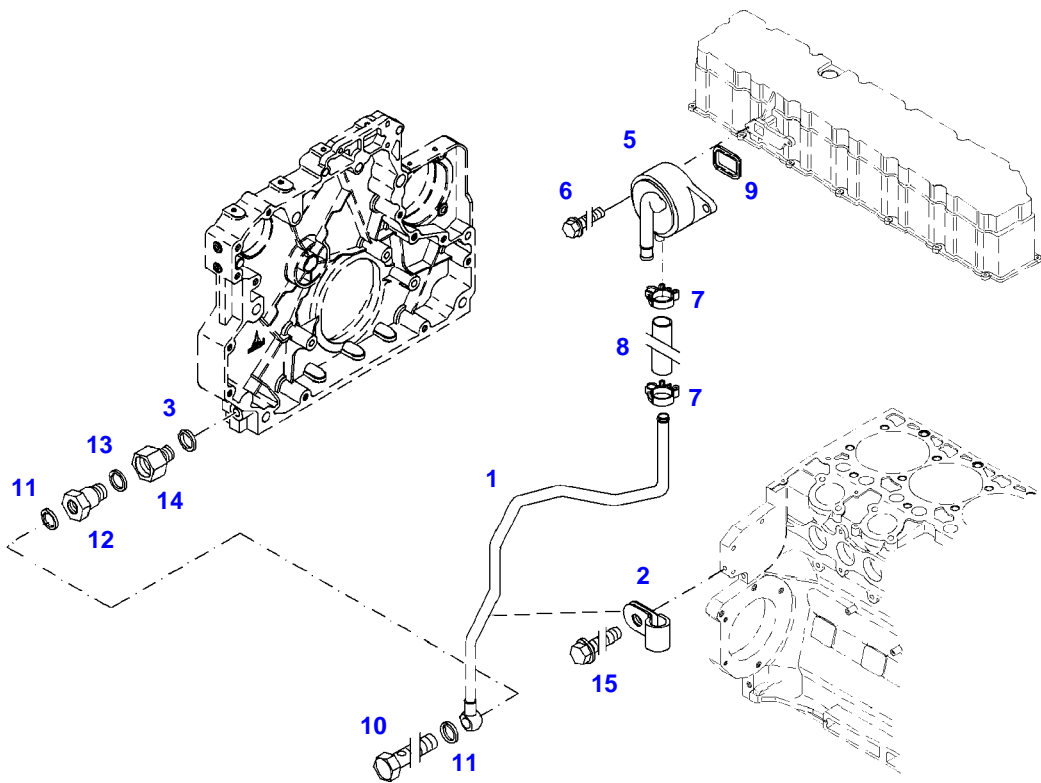

040970

Item	Part Number	Qty	Description Comments	Technical Specification
			ENGINE NUMBER --> 10343499	
1	72438755	1	RETURN LINE ><10,11 <>	
	72485771	1	LOCK VALVE	
2	72452000	1	PIPE CLAMP	
3	72315090	1	SEALING WASHER	DIN 7603 A12X15,5-CU
5	72437250	1	BREATHER ><9	
6	72325293	2	HEXAGONAL HEAD BOLT M8X30	M8X30
7	72325537	2	HOSE CLIP	
8	72452001	1	RUBBER HOSE	
9	72455795	1	SEAL	
10	72323517	1	BANJO BOLT	
11	72315092	2	SEALING WASHER	DIN 7603 A12X16-CU
12	72452002	1	CHECK VALVE <-- F946.201.210.140 1X <>	
	72438755	1	RETURN LINE	
13	72452003	1	SEALING WASHER	
14	72452004	1	ADAPTER	
15	72415878	1	HEXAGONAL HEAD BOLT M8X16	

FENDT 930 (928/00101-99999)
40971

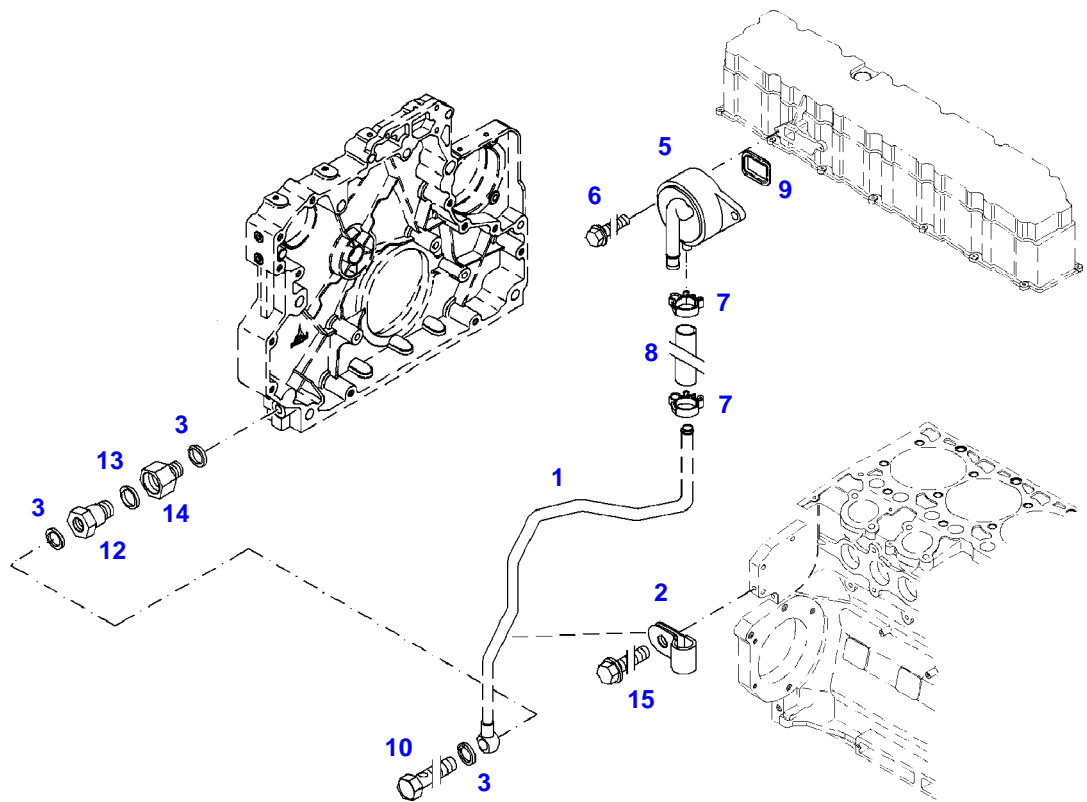

040971

Item	Part Number	Qty	Description Comments	Technical Specification
			ENGINE NUMBER <-- 10343500	
1	72438755	1	RETURN LINE ><2,3,10	
2	72454982	1	PIPE CLAMP	
3	72315090	3	SEALING WASHER	DIN 7603 A12X15,5-CU
5	72437250	1	BREATHER ><9	
6	72325293	2	HEXAGONAL HEAD BOLT M8X30	M8X30
7	72607524	2	HOSE CLIP	
8	72452001	1	RUBBER HOSE	
9	72455795	1	SEAL	
10	72323517	1	BANJO BOLT	
12	72485771	1	LOCK VALVE ><13,14	
13	72315101	1	SEALING WASHER	DIN 7603 A22X27-CU
14	72452004	1	ADAPTER	
15	72415878	1	HEXAGONAL HEAD BOLT M6X16	

FENDT 930 (928/00101-99999)
35675

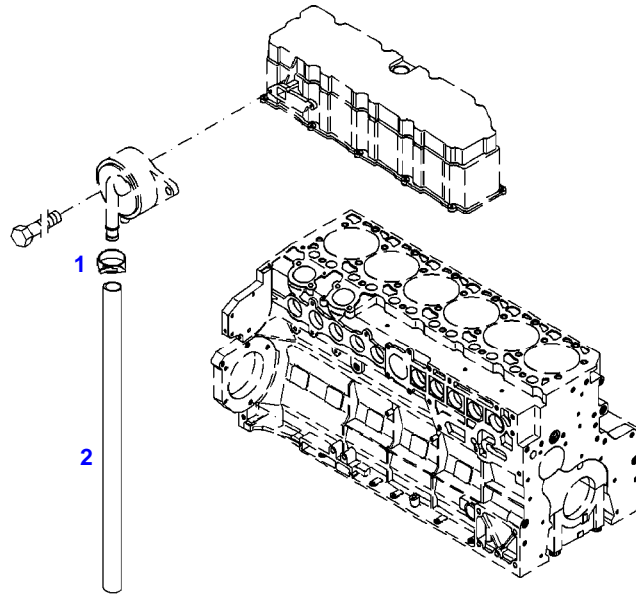

035675

Fendt

FENDT 930 (928/00101-99999)

F928000

CRANKCASE BREATHER

Page01-0011

Item	Part Number	Qty	Description Comments	Technical Specification
			BREATHER TUBE	
1	72311167	1	HOSE CLIP	
2	72450415	1	HOSE	L=900 DIN73411-22X3,5 R

FENDT 930 (928/00101-99999)
41153

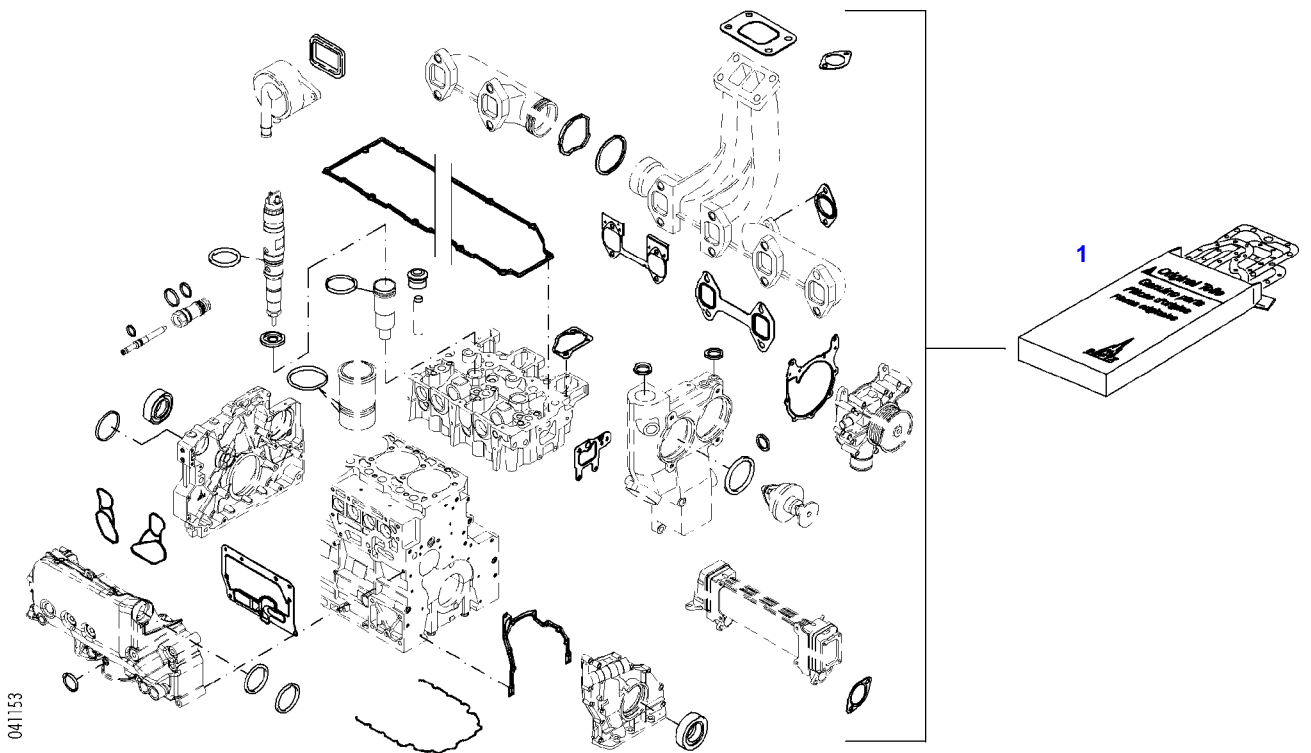

Fendt

FENDT 930 (928/00101-99999)

F928000

SET OF GASKETS

Page01-0012

Item	Part Number	Qty	Description Comments
			ENGINE
1	72452385	1	SEAL KIT WITHOUT CYLINDER HEAD GASKET

FENDT 930 (928/00101-99999)
35634

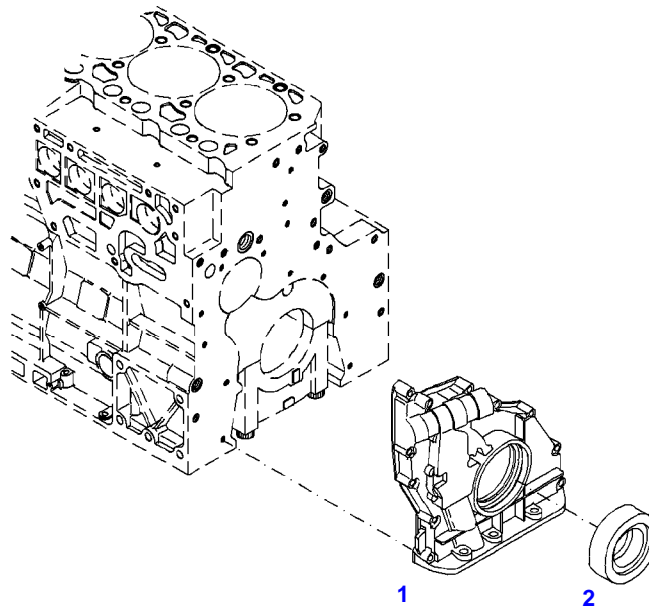

035634

Fendt

FENDT 930 (928/00101-99999)

F928000

FRONT COVER

Page01-0013

Item	Part Number	Qty	Description Comments
			INTEGRATED OIL PUMP ENGINE NUMBER --> 10989250
1	72485249	1	CRANKCASE END COVER INTEGRATED OIL PUMP ><2
2	72485251	1	SHAFT SEAL

FENDT 930 (928/00101-99999)
41280

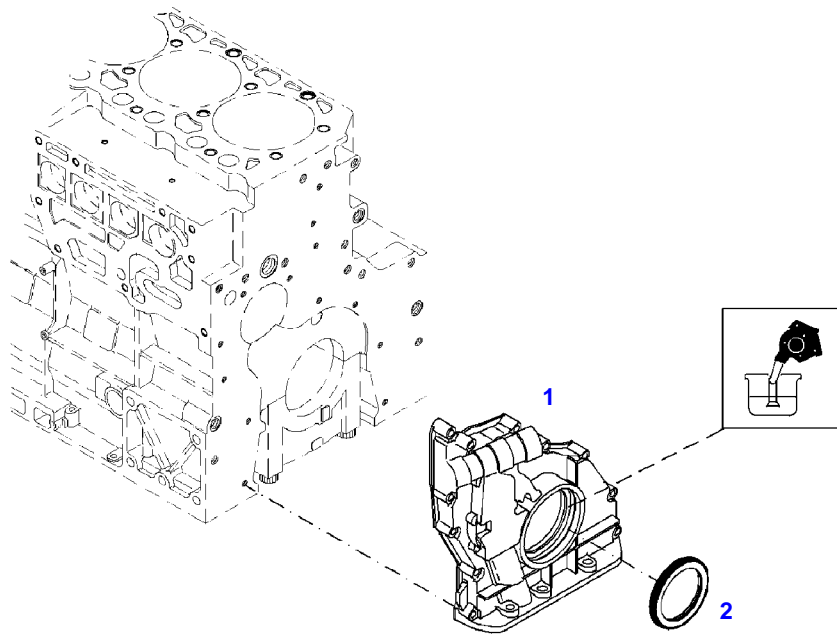

041280

Fendt

FENDT 930 (928/00101-99999)

F928000

FRONT COVER

Page01-0014

Item	Part Number	Qty	Description Comments
			INTEGRATED OIL PUMP ENGINE NUMBER <-- 10989251
1	72485249	1	CRANKCASE END COVER ><2
2	72485251	1	SHAFT SEAL

FENDT 930 (928/00101-99999)
40931

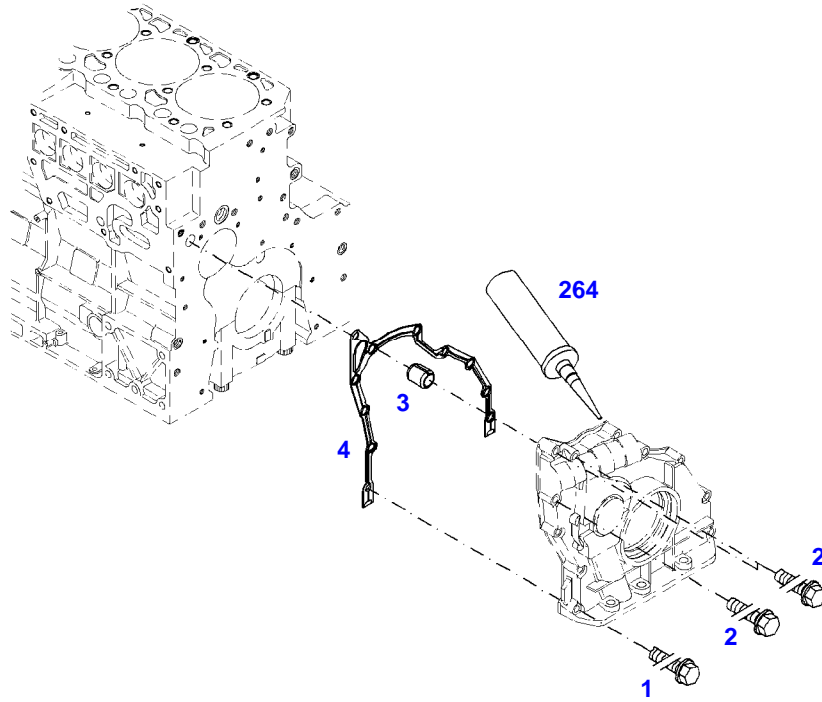

040931

Item	Part Number	Qty	Description Comments	Technical Specification
FASTENINGS				
1	72605244	8	HEXAGONAL HEAD BOLT M8X35	M8X35
2	72452006	3	HEXAGONAL HEAD BOLT M8X70	
3	72325352	1	TENSIONER BUSHING	
4	72452007	1	SEAL	
264	72438062	1	SEALING COMPOUND	

FENDT 930 (928/00101-99999)
35636

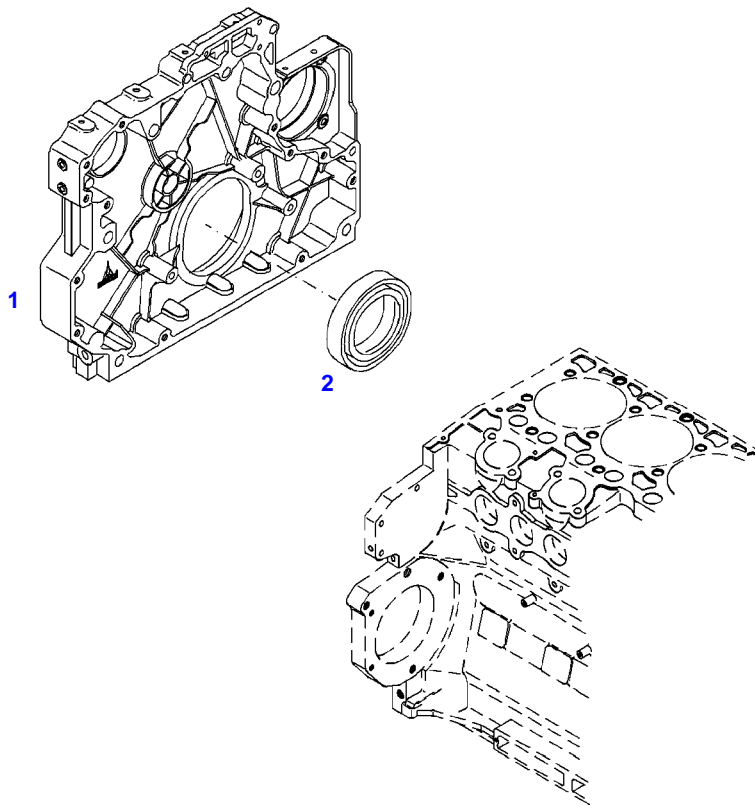

035636

Fendt

FENDT 930 (928/00101-99999)

F928000

GEARCASE

Page01-0016

Item	Part Number	Qty	Description Comments
1	72619324	1	WHEEL BOX
2	72415842	1	SHAFT SEAL

FENDT 930 (928/00101-99999)
35637

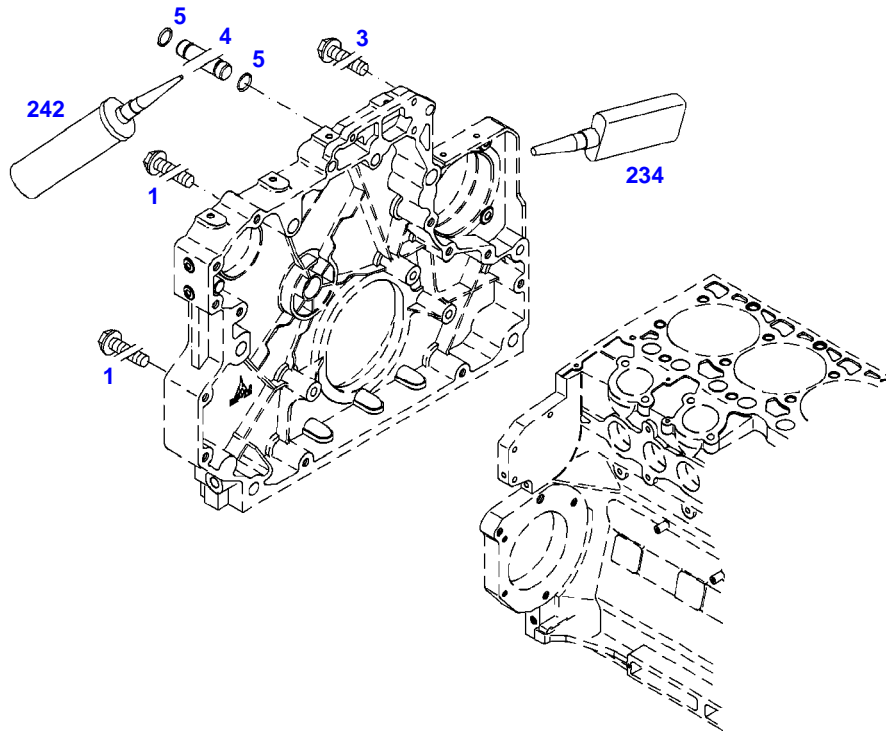

035637

Item	Part Number	Qty	Description Comments	Technical Specification
			FASTENINGS ENGINE NUMBER --> 10436063	
1	72325393	8	HEXAGONAL HEAD BOLT M8X65	
3	72325293	2	HEXAGONAL HEAD BOLT M8X30	M8X30
4	72452009	1	BOLT ><5	
5	72452010	2	SEAL 42X4MM	
234	72325408	1	SEALING COMPOUND	
242	72325276	1	INSTALLATION AIDS	

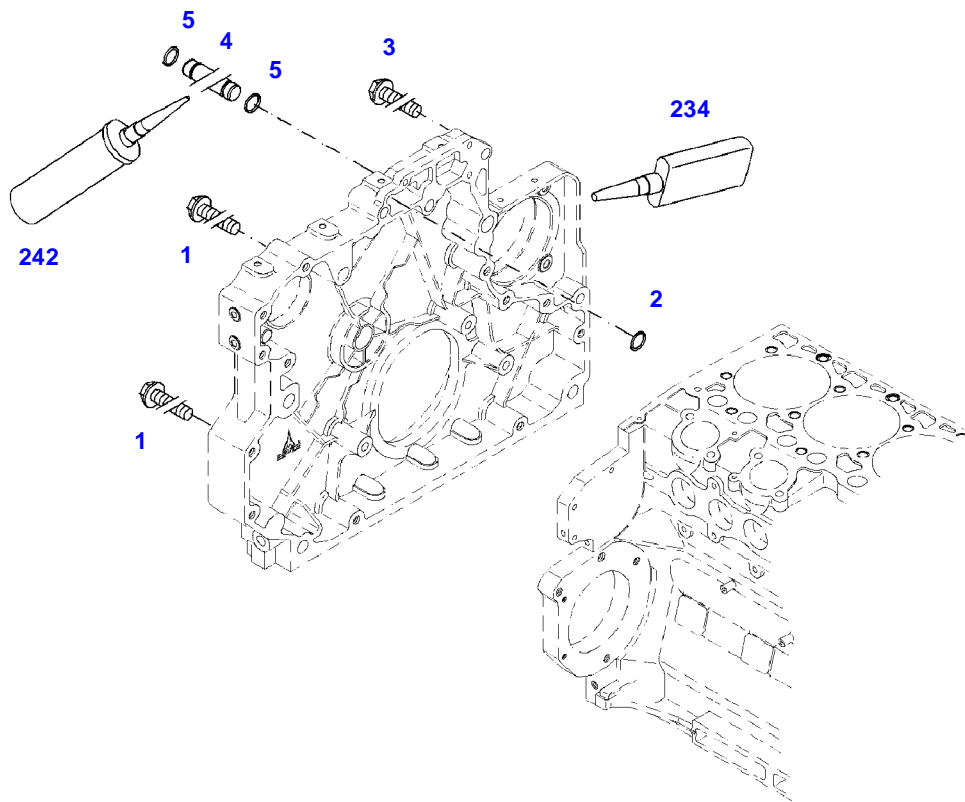

041039

Item	Part Number	Qty	Description Comments	Technical Specification
			FASTENINGS ENGINE NUMBER <-- 10436064	
1	72325393	8	HEXAGONAL HEAD BOLT M8X65	
2	72415664	1	SEAL 7X3MM	
3	72325293	2	HEXAGONAL HEAD BOLT M8X30	M8X30
4	72452009	1	BOLT ><5	
5	72452010	2	SEAL 42X4MM	
234	72325408	1	SEALING COMPOUND	
242	72325276	1	INSTALLATION AIDS	

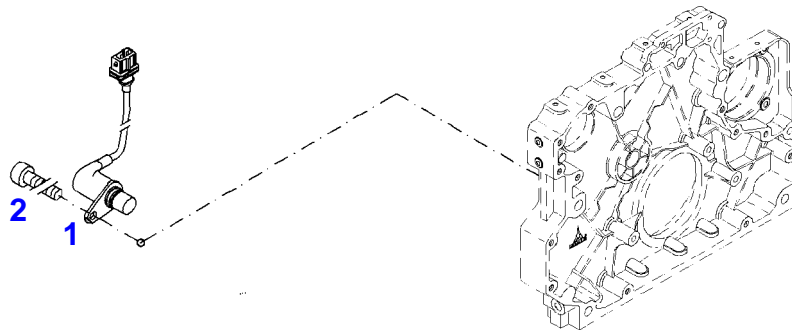

040932

Fendt

FENDT 930 (928/00101-99999)

F928000

IMPULSETRANSMITTER

Page01-0019

Item	Part Number	Qty	Description Comments	Technical Specification
			CAM SHAFT	
1	72452011	1	ENGINE SPEED SENSOR CAM SHAFT	
2	72315460	1	SOCKET HEAD BOLT	DIN 912 M6X16-8.8

FENDT 930 (928/00101-99999)
35639

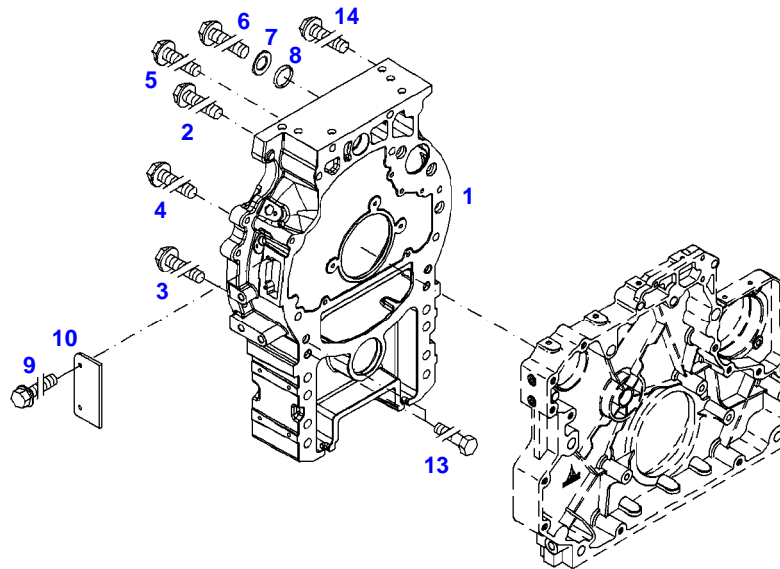

035639

Item	Part Number	Qty	Description Comments	Technical Specification
			ENGINE NUMBER --> 10280405	
1	72452020	1	CONNECTING HOUSING <-- F934.201.210.620 1X <>	
	72374344	2	HEXAGONAL HEAD BOLT	DIN 931 M20X70-10.9
	72474374	1	OIL PAN	
2	72452012	1	HEXAGONAL HEAD BOLT M16X200	
3	72452013	3	HEXAGONAL HEAD BOLT M16X120	
4	72452014	8	HEXAGONAL HEAD BOLT M8X70	
5	72452015	1	HEXAGONAL HEAD BOLT M12X130	
6	72452016	1	HEXAGONAL HEAD BOLT M16X1,5X180	
7	72452021	1	DISC	
8	72452017	1	SEAL 16X4MM	
9	72415315	2	HEXAGONAL HEAD BOLT M8X20	M8X20
10	72452022	1	COVER	
13	72452018	4	HEXAGONAL HEAD BOLT M18X70	
14	72452019	1	HEXAGONAL HEAD BOLT M12X190	

FENDT 930 (928/00101-99999)
40933

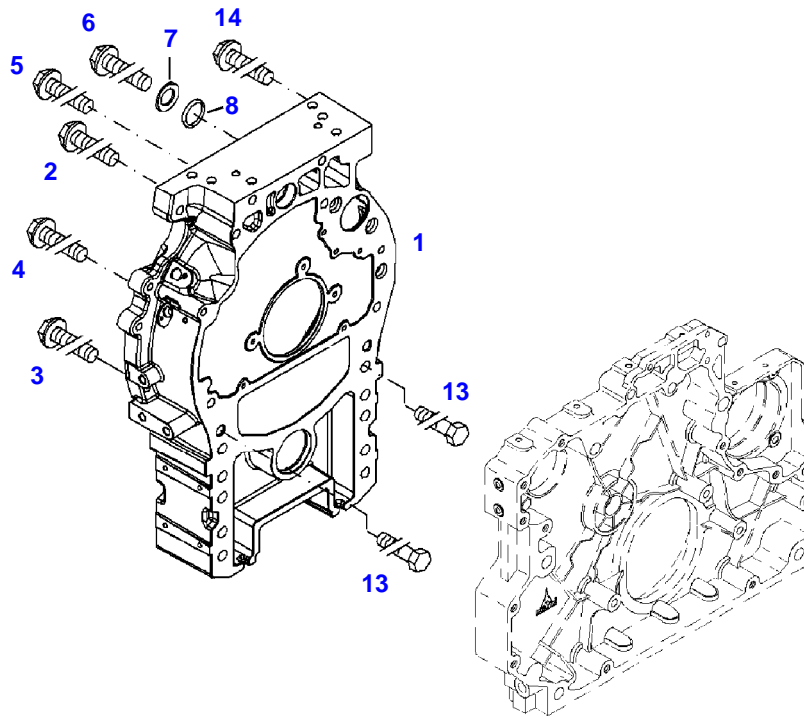

040933

Thank you so much for reading.
Please click the “Buy Now!”
button below to download the
complete manual.



After you pay.

You can download the most
perfect and complete manual in
the world immediately.

Our support email:

ebooklibonline@outlook.com