

Page Number	Page Title	Page Reference
01-000-TOC	ENGINE, FUEL AND EXHAUST SYSTEM	01-000-TOC
02-000-TOC	AXLES	02-000-TOC
03-000-TOC	STEERING SYSTEM	03-000-TOC
04-000-TOC	DRIVE TRAIN SYSTEM	04-000-TOC
05-000-TOC	COMPRESSED AIR SYSTEM	05-000-TOC
06-000-TOC	HYDRAULIC SYSTEM	06-000-TOC
07-000-TOC	ELECTRICAL SYSTEM	07-000-TOC
08-000-TOC	CAB	08-000-TOC
09-000-TOC	AIR CONDITIONING AND HEATING SYSTEM	09-000-TOC
10-000-TOC	CHASSIS	10-000-TOC
11-000-TOC	WHEELS	11-000-TOC
12-000-TOC	IMPLEMENT LIFT SYSTEM FRONT	12-000-TOC
13-000-TOC	IMPLEMENT LIFT SYSTEM REAR	13-000-TOC
14-000-TOC	PRECISION FARMING SYSTEMS	14-000-TOC
15-000-TOC	ACCESSORIES	15-000-TOC

FENDT 930 TIER III (943/01001-99999)
41276

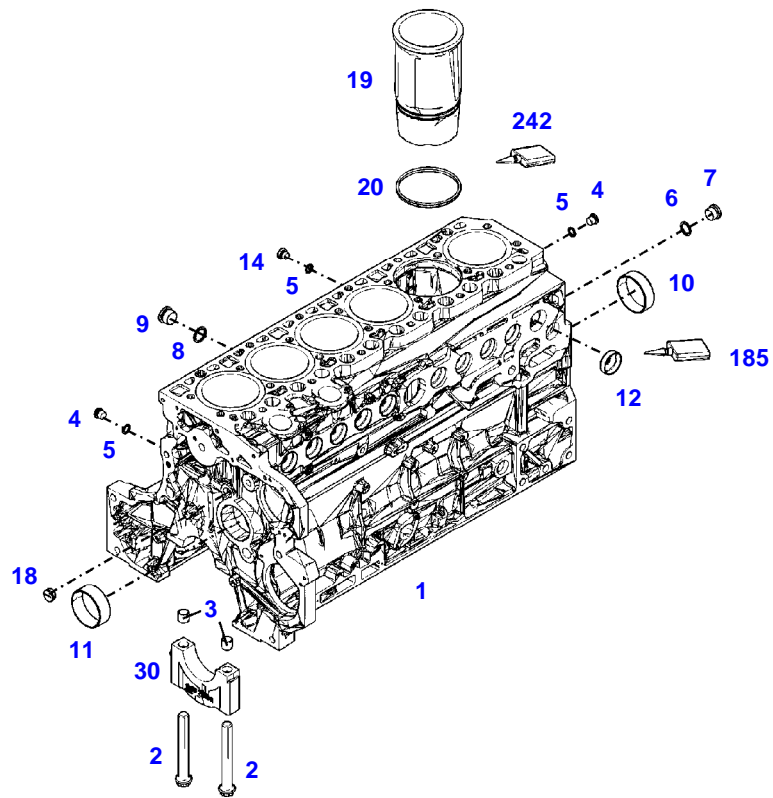



041276

Item	Part Number	Qty	Description Comments	Technical Specification
	E943201010100	1	ENGINE	TCD7.8L6
1	F946201210020	1	CRANKCASE ><2-12,14,18-20,30	
2	F934201210020	14	SCREW	
3	F934201210030	14	ADAPTER BUSH	
4	X483800800000	2	PLUG SCREW	DIN 908 M14X1,5-ST
5	F731200060160	3	SEALING WASHER 14X18MM	DIN7603-14X18-CU-VERZ
6	F731200210190	1	SEALING WASHER	
7	X483802400000	1	PLUG	DIN 908 M22X1,5-ST
8	F946201210010	1	SEALING WASHER 26X31MM	26X31
9	X483803201000	1	SCREW	DIN 908-M26X1,5-ST-A3L
10	F934201210050	6	BEARING BUSHING	
11	F934201210060	1	BEARING BUSHING	
12	F119200210070	10	CORE HOLE PLUG	
14	X494203800000	1	PLUG	DIN 7604 AM14X1,5-A3L
18	F716201210010	1	PLUG	
19	F946201210030	6	CYLINDER LINER ><20	
20	F004200210110	12	SEAL 112X3MM	
30			NOT AVAILABLE IN SINGLE PARTS	
185	F119200210850	1	SAFE.LOCK AGENT	
242	F119200040090	1	INSTALLATION AIDS	

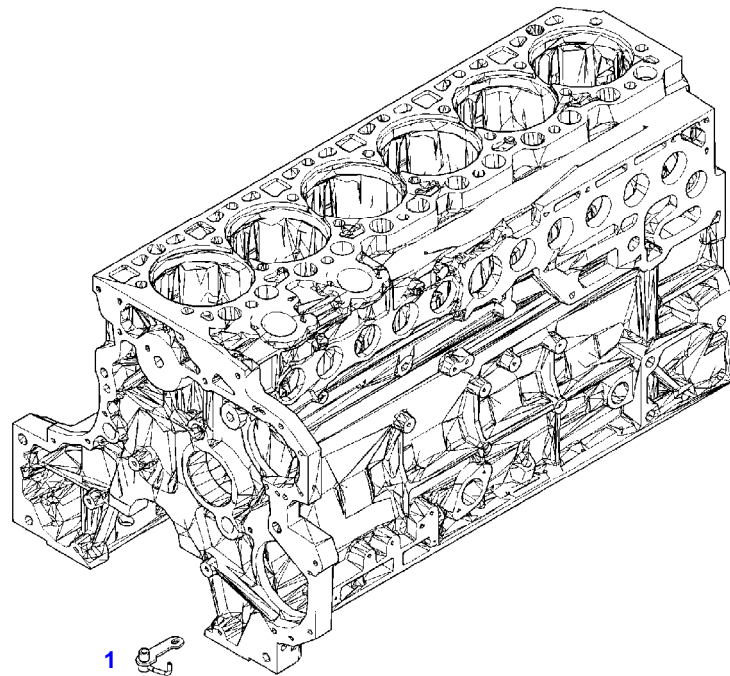
FENDT 930 TIER III (943/01001-99999)
41277



- 1 
- 2 

041277

Fendt

FENDT 930 TIER III (943/01001-99999)

F943003

CRANKCASE

Page01-0002

Item	Part Number	Qty	Description Comments	Technical Specification
			PISTON COOL.NOZZLE	
1	F946201210040	6	PISTON COOLING JET	
2	F416200210030	6	HEXAGONAL HEAD BOLT M8X35	M8X35

FENDT 930 TIER III (943/01001-99999)
41284

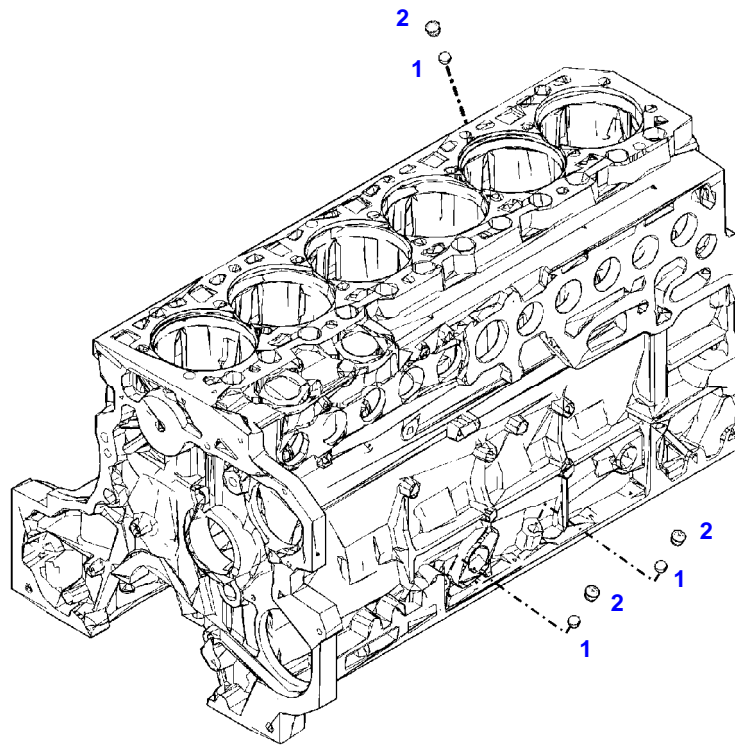

041284

Fendt

FENDT 930 TIER III (943/01001-99999)

F943003

CRANKCASE

Page01-0003

Item	Part Number	Qty	Description Comments
			LOCKING PLUG
1	F934201210750	3	BALL
2	F934201210810	3	LOCKING PLUG

FENDT 930 TIER III (943/01001-99999)
41319

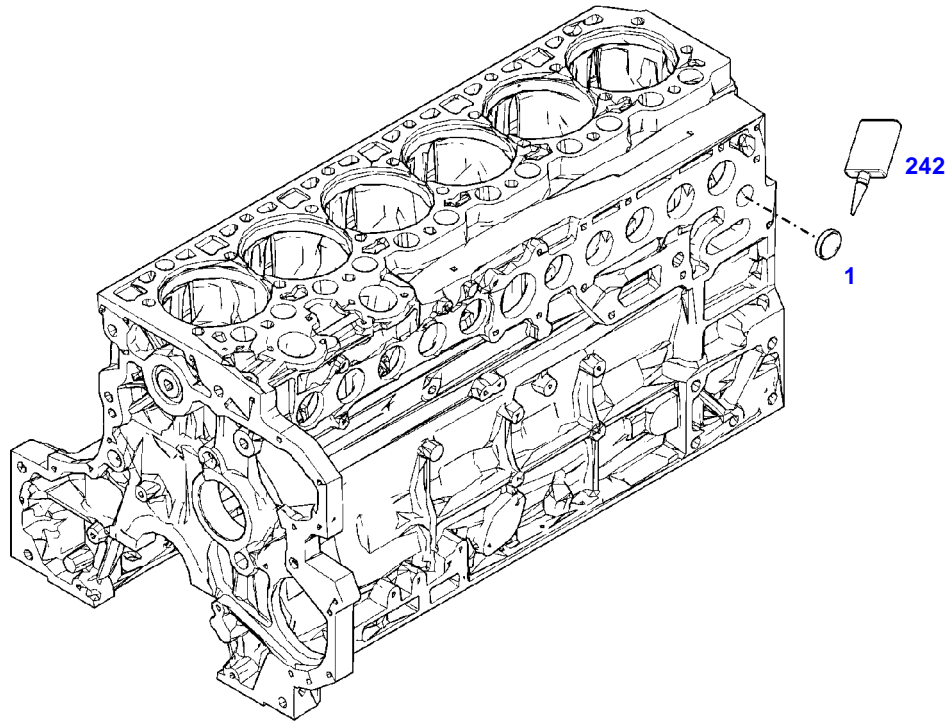

041319

Fendt

FENDT 930 TIER III (943/01001-99999)

F943003

CRANKCASE

Page01-0004

Item	Part Number	Qty	Description Comments	Technical Specification
			LOCKING PLUG	
1	F946201210050	1	CORE HOLE PLUG	
242	X903050084000	1	THREADLOCKER	LOCTITE 243 10ML

FENDT 930 TIER III (943/01001-99999)
35632

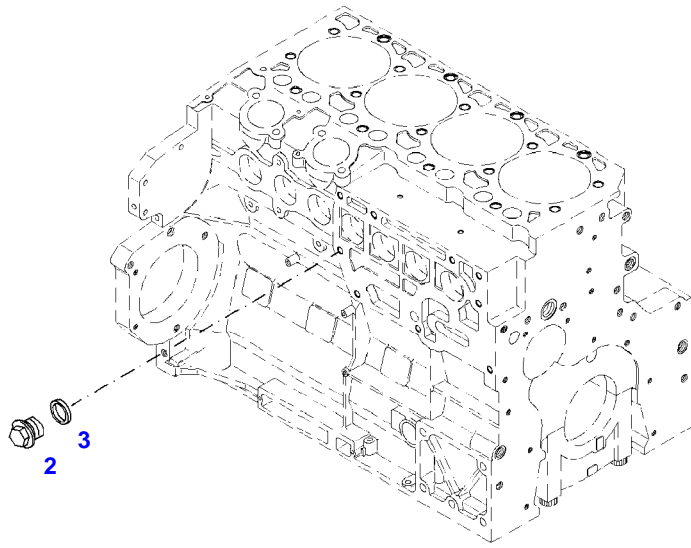

035632

Fendt

FENDT 930 TIER III (943/01001-99999)

F943003

CRANKCASE

Page01-0005

Item	Part Number	Qty	Description Comments	Technical Specification
BLANKING PARTS				
2	X494203800000	1	PLUG	DIN 7604 AM14X1,5-A3L
3	X540004078000	1	SEALING WASHER	DIN 7603 A14X18-CU

FENDT 930 TIER III (943/01001-99999)
41337

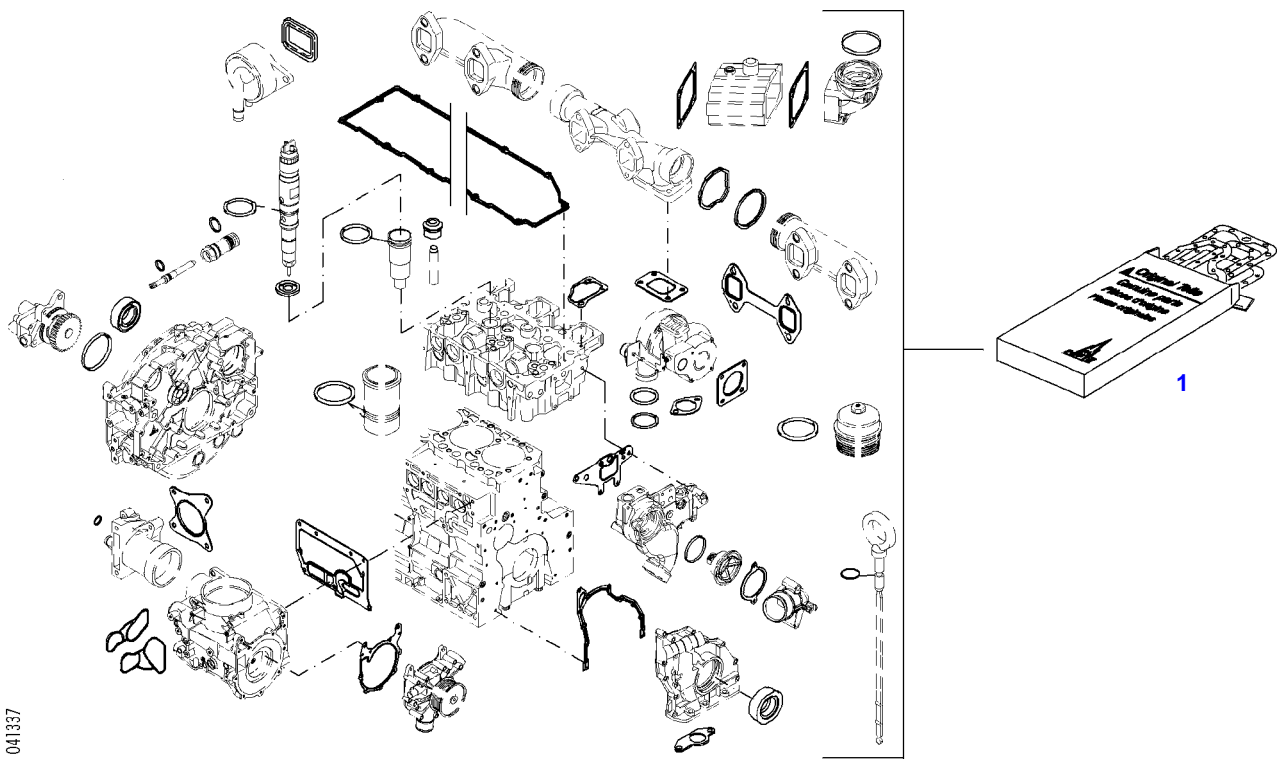

Fendt

FENDT 930 TIER III (943/01001-99999)

F943003

SET OF GASKETS

Page01-0006

Item	Part Number	Qty	Description Comments
			ENGINE
1	F946201210250	1	SEAL KIT WITHOUT CYLINDER HEAD GASKET

FENDT 930 TIER III (943/01001-99999)
41330

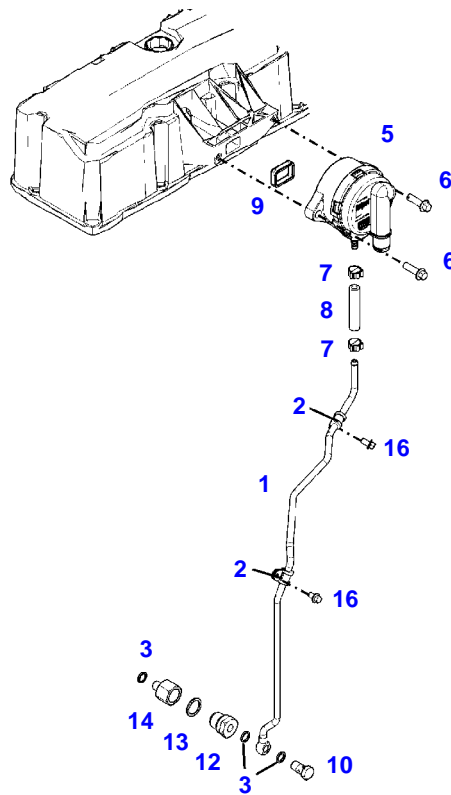

041330

Item	Part Number	Qty	Description Comments	Technical Specification
1	F946201210210	1	RETURN LINE ><2,3,10	
2	F934201210680	2	PIPE CLAMP	
3	X540003278000	3	SEALING WASHER	DIN 7603 A12X15,5-CU
5	F339202210280	1	BREATHER ><9	
6	F119200090080	2	HEXAGONAL HEAD BOLT M8X30	M8X30
7	F945201210020	2	HOSE CLIP	
8	F934201210110	1	RUBBER HOSE	
9	725200010251	1	SEAL	
10	F100001119241	1	BANJO BOLT	
12	F946201210140	1	LOCK VALVE ><13,14	
13	X540006678000	1	SEALING WASHER	DIN 7603 A22X27-CU
14	F934201210140	1	ADAPTER	
16	F119200090150	2	HEXAGONAL HEAD BOLT M6X12	M6X12

FENDT 930 TIER III (943/01001-99999)
35675

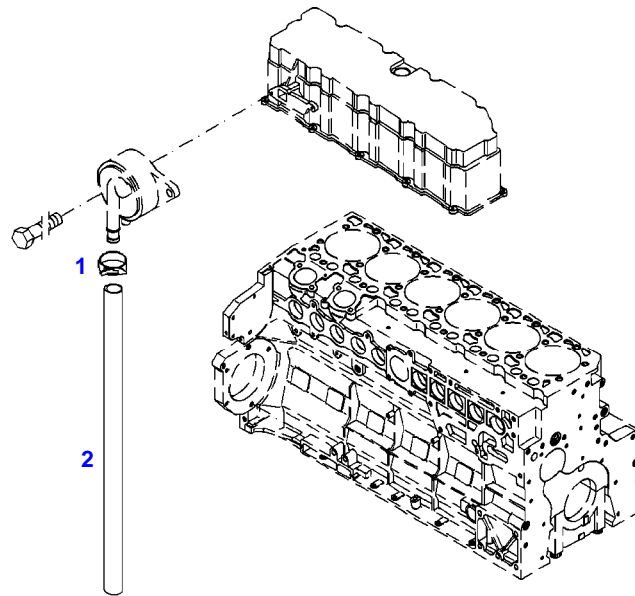

035675

Fendt

FENDT 930 TIER III (943/01001-99999)

F943003

CRANKCASE BREATHER

Page01-0008

Item	Part Number	Qty	Description Comments	Technical Specification
			BREATHER TUBE	
1	X458651300000	1	HOSE CLIP	
2	X591110000900	1	HOSE	L=900 DIN73411-22X3,5 R

FENDT 930 TIER III (943/01001-99999)
41280

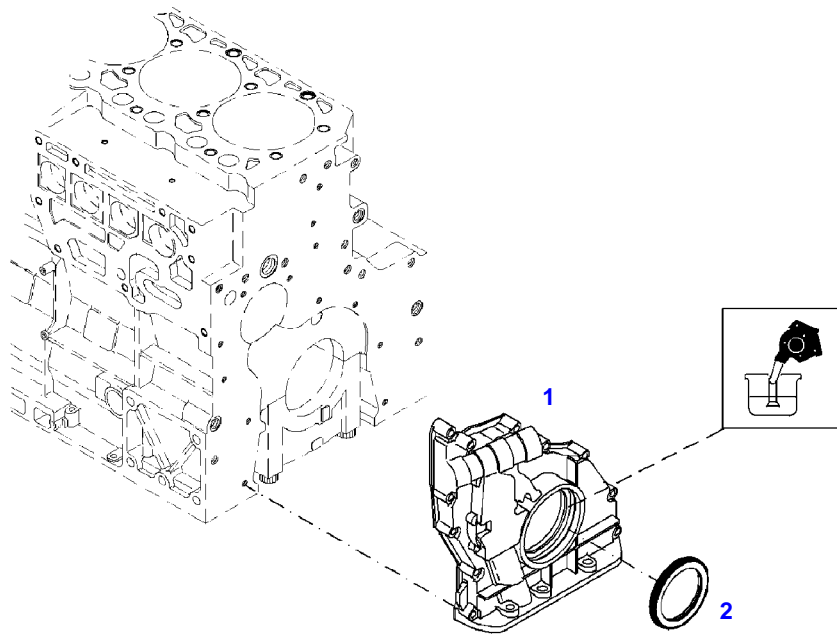

041280

Fendt

FENDT 930 TIER III (943/01001-99999)

F943003

FRONT COVER

Page01-0009

Item	Part Number	Qty	Description Comments
			INTEGRATED OIL PUMP
1	F946201210060	1	CRANKCASE END COVER ><2
2	F946201210070	1	SHAFT SEAL

FENDT 930 TIER III (943/01001-99999)
40931

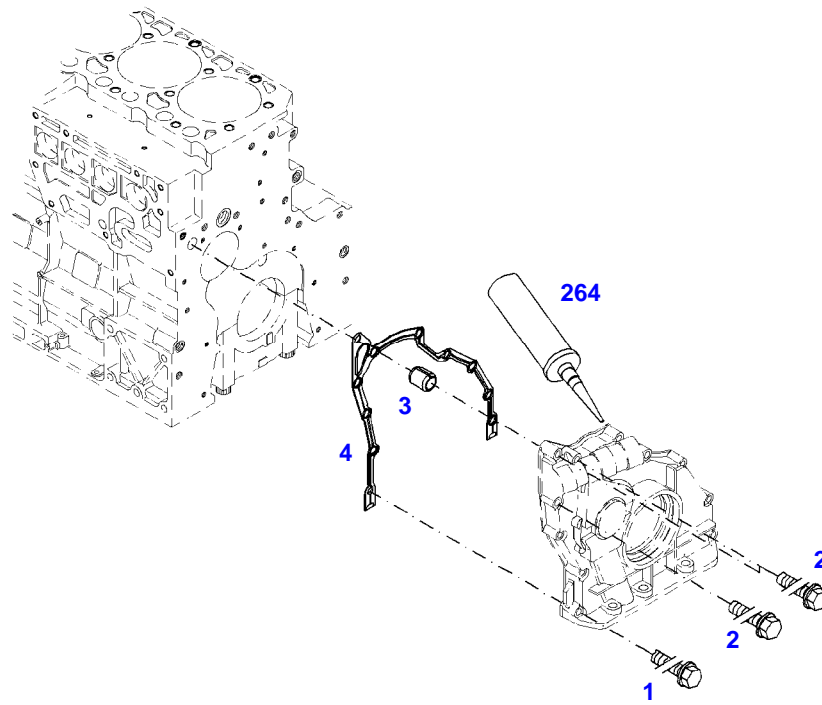

040931

Item	Part Number	Qty	Description Comments	Technical Specification
FASTENINGS				
1	F416200210030	8	HEXAGONAL HEAD BOLT M8X35	M8X35
2	F934201210160	3	HEXAGONAL HEAD BOLT M8X70	
3	F119200210340	1	TENSIONER BUSH	
4	F934201210170	1	SEAL	
264	F934201210570	1	SEALING COMPOUND	

FENDT 930 TIER III (943/01001-99999)
35636

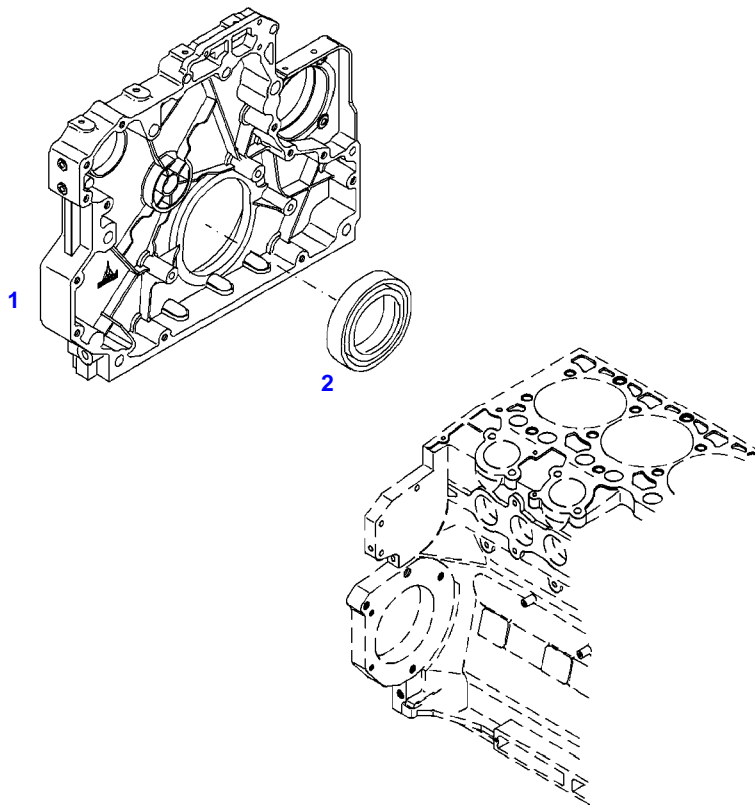

035636

Fendt

FENDT 930 TIER III (943/01001-99999)

F943003

GEARCASE

Page01-0011

Item	Part Number	Qty	Description Comments
1	F934201210840	1	WHEEL BOX
2	F946201210230	1	SHAFT SEAL

FENDT 930 TIER III (943/01001-99999)
41039

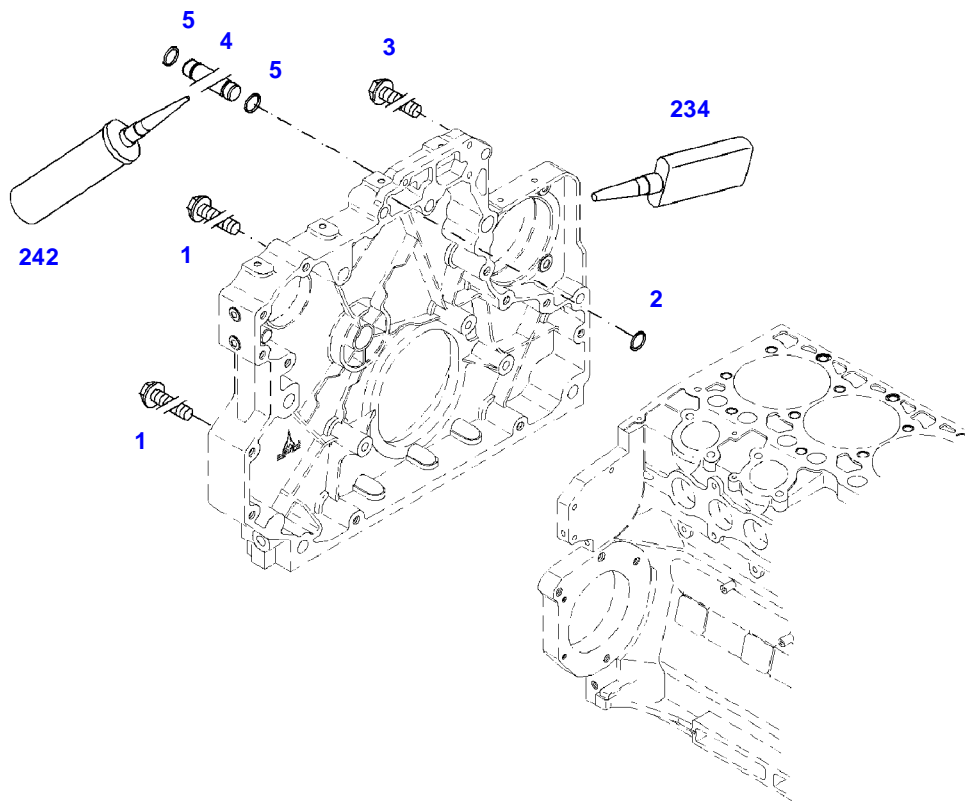

041039

Item	Part Number	Qty	Description Comments	Technical Specification
FASTENINGS				
1	F119200210750	8	HEXAGONAL HEAD BOLT M8X65	
2	F002200710040	1	SEAL 7X3MM	
3	F119200090080	2	HEXAGONAL HEAD BOLT M8X30	M8X30
4	F934201210190	1	BOLT ><5	
5	F934201210200	2	SEAL 42X4MM	
234	F119200210900	1	SEALING COMPOUND	
242	F119200040090	1	INSTALLATION AIDS	

FENDT 930 TIER III (943/01001-99999)
40932

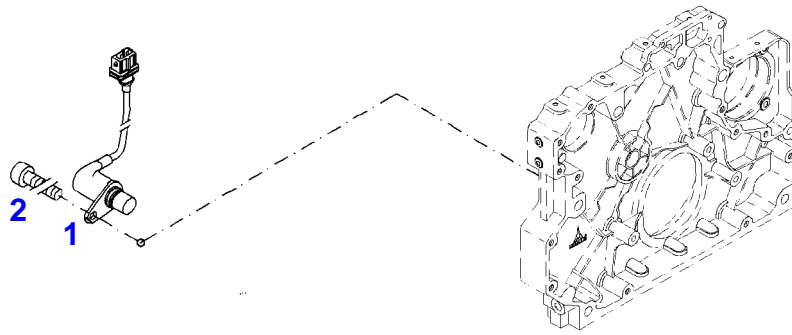

040932

Fendt

FENDT 930 TIER III (943/01001-99999)

F943003

IMPULSETRANSMITTER

Page01-0013

Item	Part Number	Qty	Description Comments	Technical Specification
			CAM SHAFT	
1	F934201210210	1	ENGINE SPEED SENSOR CAM SHAFT	
2	X485004405000	1	SOCKET HEAD BOLT	DIN 912 M6X16-8.8

FENDT 930 TIER III (943/01001-99999)
40933

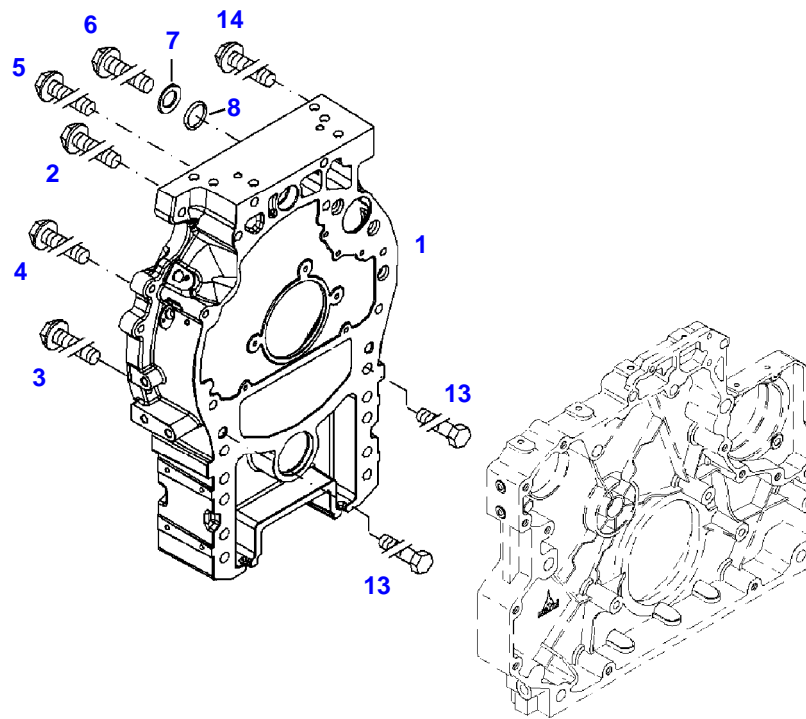

040933

Item	Part Number	Qty	Description Comments	Technical Specification
1	F934201210620	1	CONNECTING HOUSING	
2	F934201210220	1	HEXAGONAL HEAD BOLT M16X200	
3	F934201210230	3	HEXAGONAL HEAD BOLT M16X120	
4	F934201210240	8	HEXAGONAL HEAD BOLT M8X70	
5	F934201210250	1	HEXAGONAL HEAD BOLT M12X130	
6	F934201210260	1	HEXAGONAL HEAD BOLT M16X1,5X180	
7	F934201210310	1	DISC	
8	F934201210270	1	SEAL 16X4MM	
13	X486555301000	2	HEXAGONAL HEAD BOLT	DIN 931 M20X70-10.9
14	F934201210290	1	HEXAGONAL HEAD BOLT M12X190	

FENDT 930 TIER III (943/01001-99999)
40934

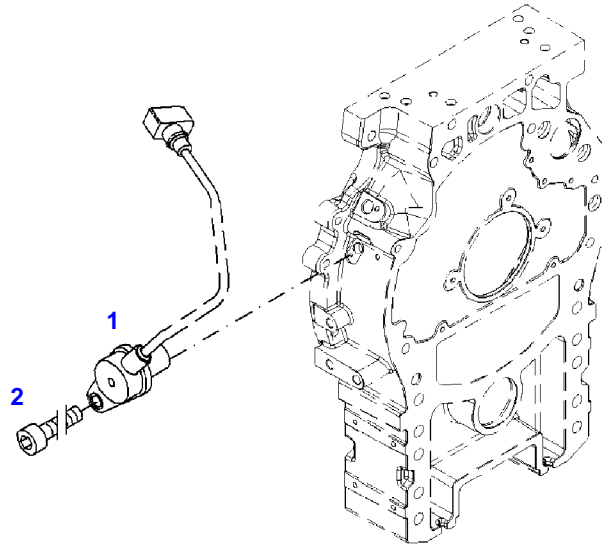

040934

Fendt

FENDT 930 TIER III (943/01001-99999)

F943003

IMPULSETRANSMITTER

Page01-0015

Item	Part Number	Qty	Description Comments	Technical Specification
			FLYWHEEL	
1	F339202210180	1	TRANSMITTER FLYWHEEL	
2	X485004405000	1	SOCKET HEAD BOLT	DIN 912 M6X16-8.8

FENDT 930 TIER III (943/01001-99999)
41281

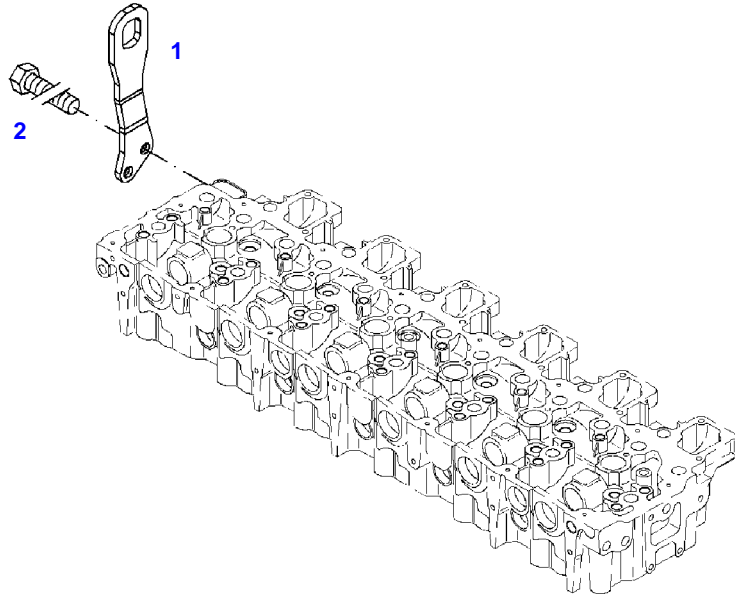

041281

Fendt

FENDT 930 TIER III (943/01001-99999)

F943003

ENGINE MOUNTING

Page01-0016

Item	Part Number	Qty	Description Comments
1	F946201210090	1	SUSPENSION PLATE
2	F946201210080	2	HEXAGONAL HEAD BOLT M12X25

FENDT 930 TIER III (943/01001-99999)
41388

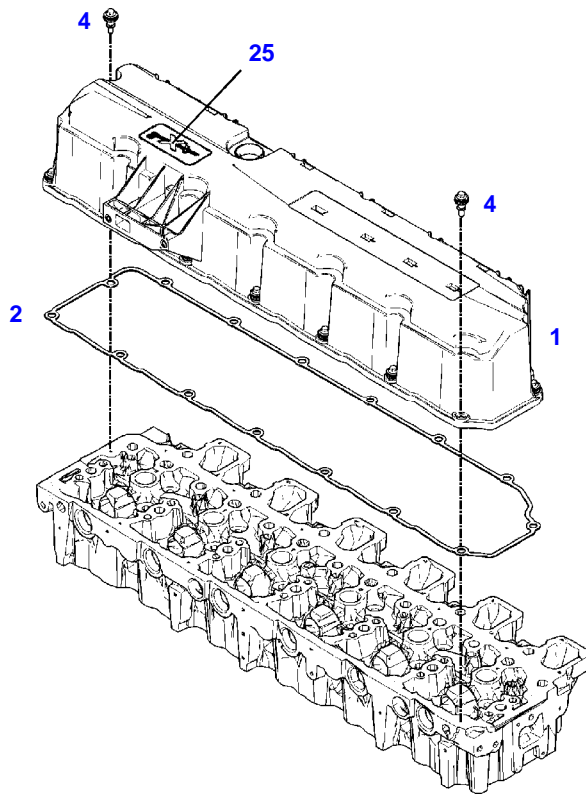

041388

Item	Part Number	Qty	Description Comments
1	F934201210790	1	VALVE COVER ><2,4
2	F934201210010	1	SEAL
4	F934201210370	15	SCREW
25		1	NO SPARE PART

FENDT 930 TIER III (943/01001-99999)
35643

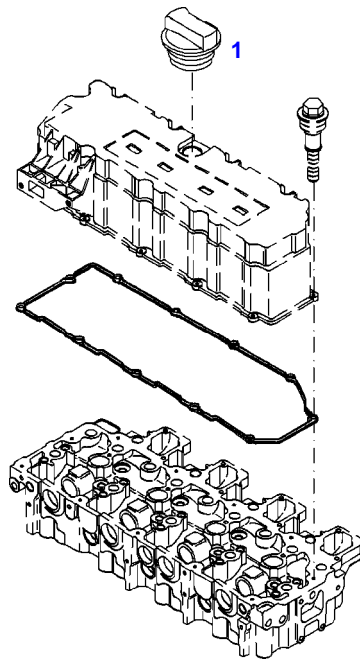

035643

Fendt

FENDT 930 TIER III (943/01001-99999)

F943003

VALVE COVER

Page01-0018

Item	Part Number	Qty	Description Comments
			FILLER CAP
1	F934201210380	1	FILLER LOCK

FENDT 930 TIER III (943/01001-99999)
41286

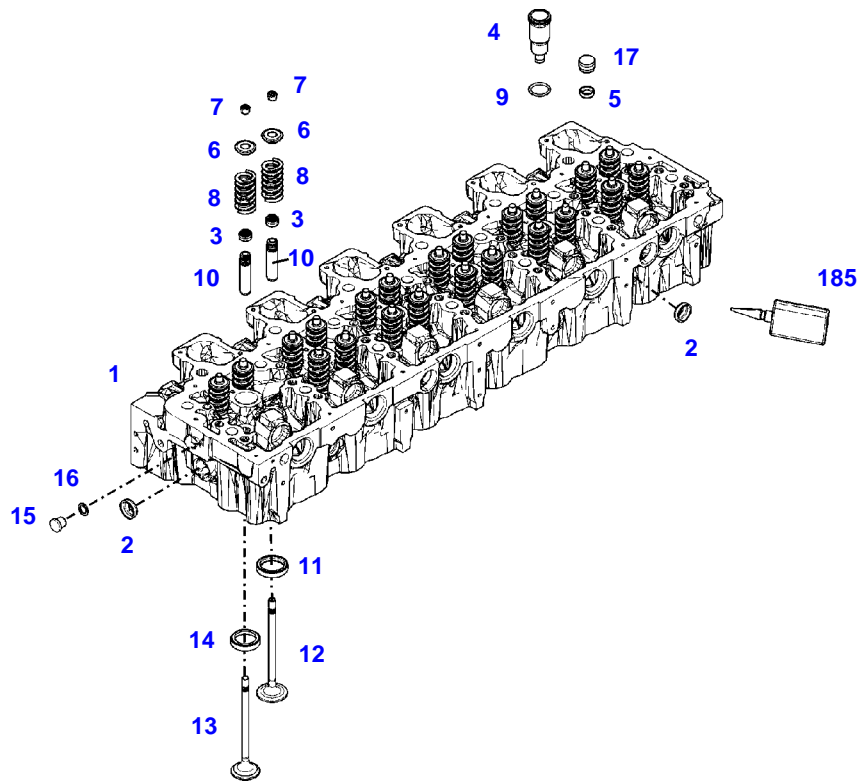

041286

Thank you so much for reading.
Please click the “Buy Now!”
button below to download the
complete manual.



After you pay.

You can download the most
perfect and complete manual in
the world immediately.

Our support email:

ebooklibonline@outlook.com