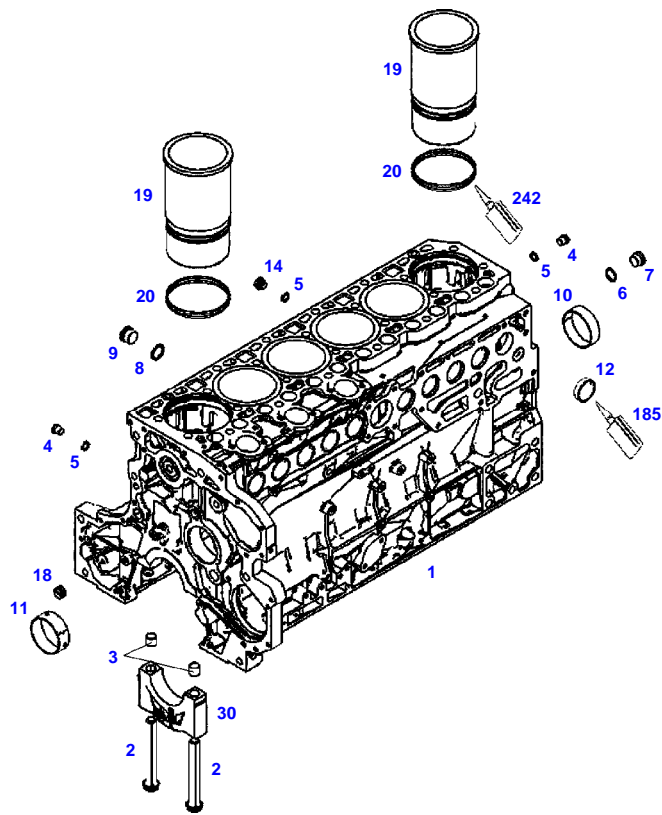

**TABLE OF CONTENT**

<b>Page Number</b>	<b>Page Title</b>	<b>Page Reference</b>
01-000-TOC	ENGINE, FUEL AND EXHAUST SYSTEM	01-000-TOC
02-000-TOC	AXLES	02-000-TOC
03-000-TOC	STEERING SYSTEM	03-000-TOC
04-000-TOC	DRIVE TRAIN SYSTEM	04-000-TOC
05-000-TOC	COMPRESSED AIR SYSTEM	05-000-TOC
06-000-TOC	HYDRAULIC SYSTEM	06-000-TOC
07-000-TOC	ELECTRICAL SYSTEM	07-000-TOC
08-000-TOC	CAB	08-000-TOC
09-000-TOC	AIR CONDITIONING AND HEATING SYSTEM	09-000-TOC
10-000-TOC	CHASSIS	10-000-TOC
11-000-TOC	WHEELS	11-000-TOC
12-000-TOC	IMPLEMENT LIFT SYSTEM FRONT	12-000-TOC
13-000-TOC	IMPLEMENT LIFT SYSTEM REAR	13-000-TOC
14-000-TOC	LINKAGE	14-000-TOC
15-000-TOC	PRECISION FARMING SYSTEMS	15-000-TOC
16-000-TOC	ACCESSORIES	16-000-TOC



050908

## CRANKCASE

Item	Part Number	Qty	Description Comments	Technical Specification
			FROM ENGINE S/N 12315127	
	E951200011020	1	ENGINE	TTCD7.8L6
1	F954200210360	1	CRANKCASE ><2-30	
2	F934201210020	14	SCREW	
3	F934201210030	14	ADAPTER BUSH	
4	F954200210390	2	PLUG SCREW	
5	F731200060160	3	SEALING WASHER	DIN7603-14X18-CU-VERZ
6	F731200210190	1	SEALING WASHER	
7	F954200210400	1	PLUG SCREW	DIN908-M22X1,5
8	F946201210010	1	SEALING WASHER	26X31
9	F438200510020	1	PLUG SCREW	
10	F934201210050	6	BEARING BUSHING	
11	F954200210020	1	FEMALE BEARING	
12	F119200210070	10	CORE HOLE PLUG	
14	F954200210410	1	PLUG SCREW	
18	F001200210030	1	LOCKING PLUG	
19	F954200210350	6	CYLINDER LINER	
20	F004200210110	12	SEAL	
30			NOT AVAILABLE IN SINGLE PARTS	
185	F716201210220	1	SAFE.LOCK AGENT	
242	F119200040090	1	INSTALLATION AIDS	

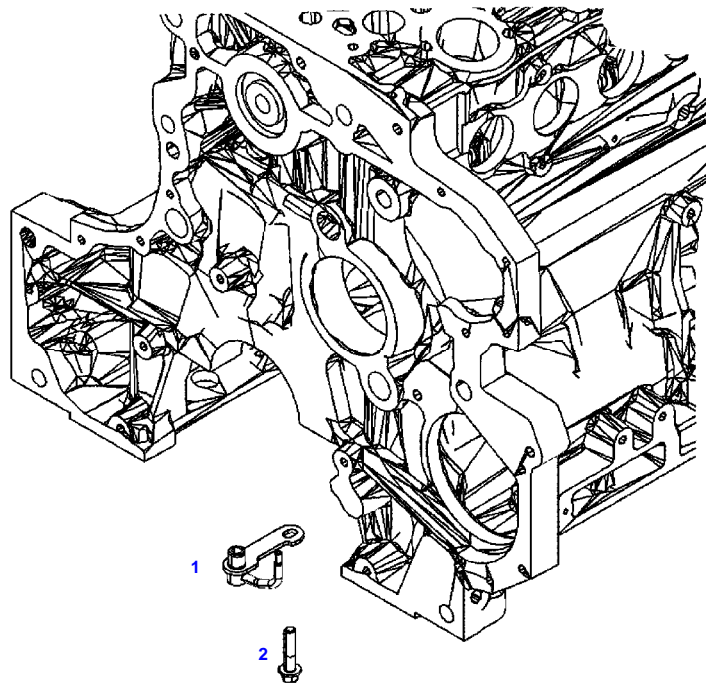

050909

Fendt

FENDT 930 S4 (NON SCR) (951/01001-05000) (WAM951XXX00F05001-99999)

F951003

CRANKCASE

Page01-0004

Item	Part Number	Qty	Description Comments	Technical Specification
			PISTON COOL.NOZZLE	
1	F954200210040	6	PISTON COOLING JET	
2	F416200210030	6	HEXAGONAL HEAD BOLT	M8X35

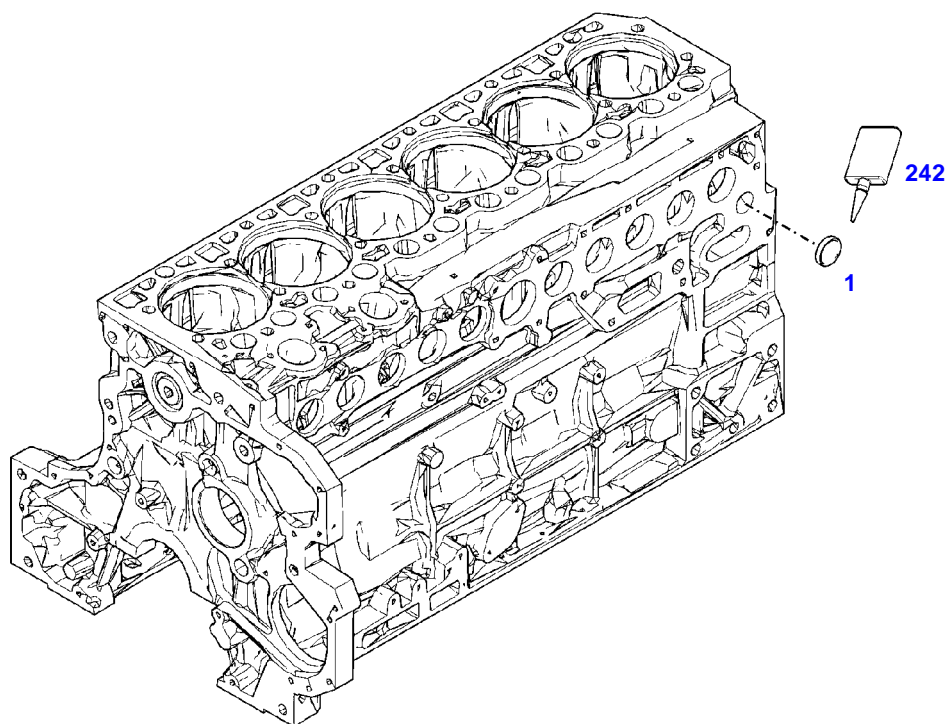

041319

Fendt

FENDT 930 S4 (NON SCR) (951/01001-05000) (WAM951XXX00F05001-99999)

F951003

CRANKCASE

Page01-0005

Item	Part Number	Qty	Description Comments	Technical Specification
			<b>LOCKING PLUG</b>	
1	F946201210050	1	CORE HOLE PLUG	
242	X903050084000	1	THREADLOCKER	LOCTITE 243 10ML

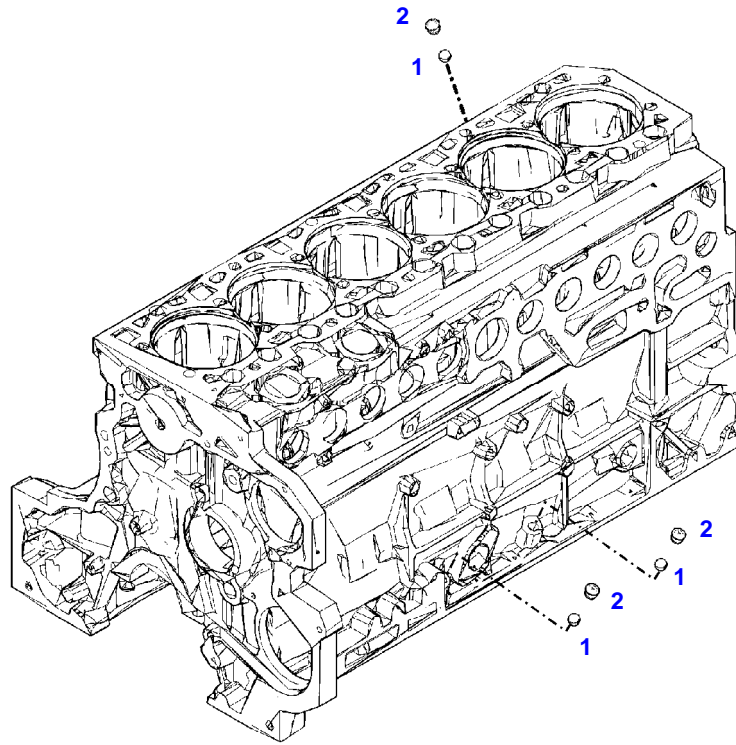

041284



---

Fendt

FENDT 930 S4 (NON SCR) (951/01001-05000) (WAM951XXX00F05001-99999)

F951003

CRANKCASE

Page01-0006

Item	Part Number	Qty	Description Comments
			LOCKING PLUG
1	F934201210750	3	BALL
2	F934201210810	3	LOCKING PLUG

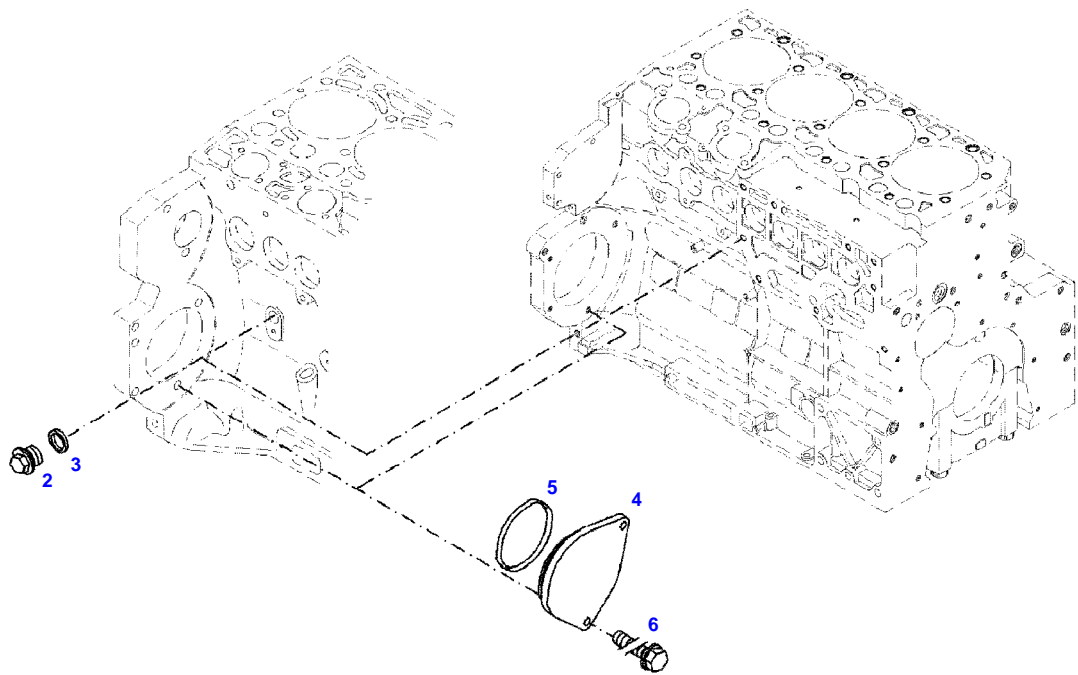

051577



Item	Part Number	Qty	Description Comments	Technical Specification
<b>BLANKING PARTS</b>				
2	X494203800000	1	PLUG NOT NEEDED WITH AIR BRAKE	DIN 7604 AM14X1,5-A3L
3	F731200060160	1	SEALING WASHER NOT NEEDED WITH AIR BRAKE	DIN7603-14X18-CU-VERZ
4	F412201210020	1	COVER NOT NEEDED WITH AIR BRAKE	
5	F716201210090	1	SEAL 96X4MM NOT NEEDED WITH AIR BRAKE	
6	F339900040220	2	HEXAGONAL HEAD BOLT NOT NEEDED WITH AIR BRAKE UP TO 2017-08	M10X20
	F438200210220	2	HEXAGONAL HEAD BOLT NOT NEEDED WITH AIR BRAKE FROM 2017-09	M10X16

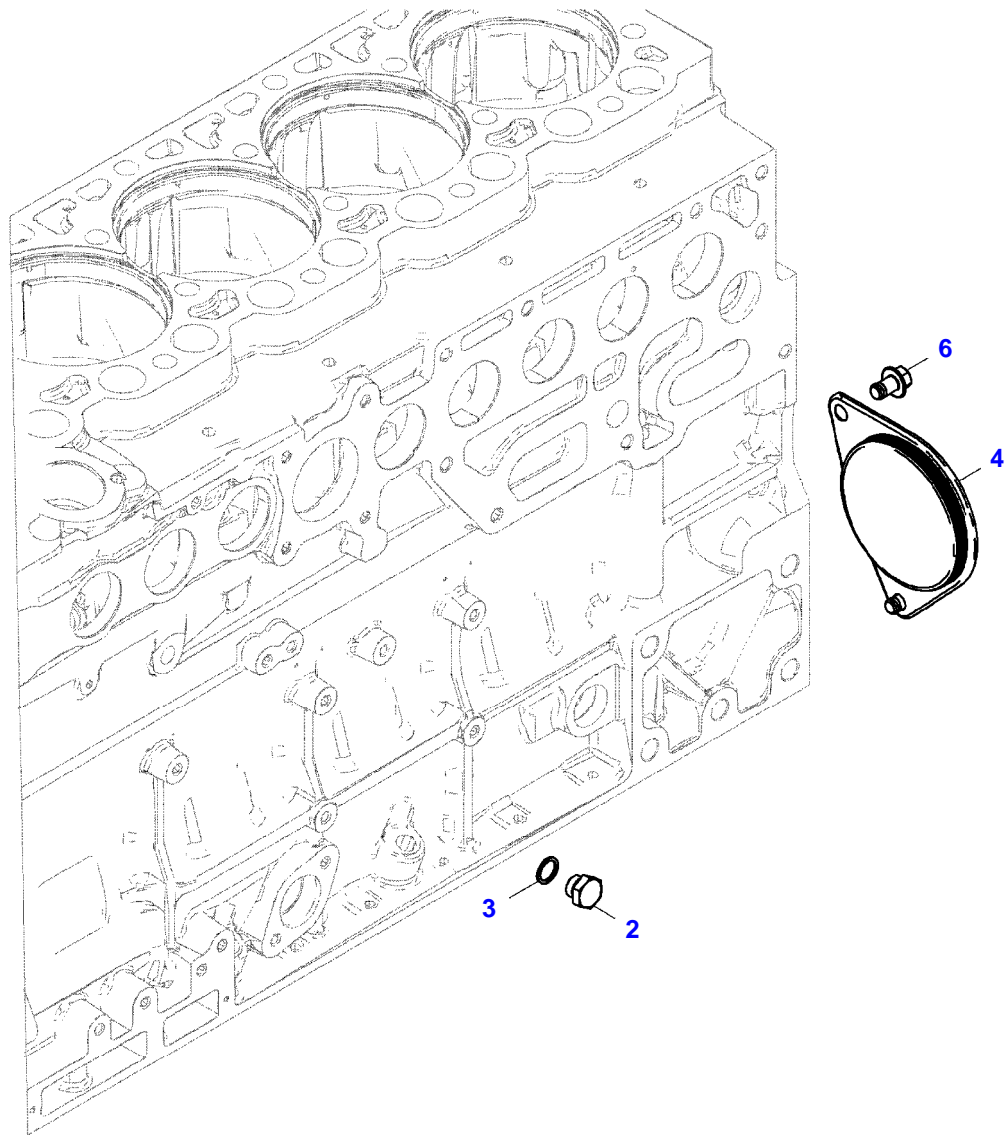

25548786-M-1

Item	Part Number	Qty	Description Comments	Technical Specification
			<b>BLANKING PARTS FROM ENGINE S/N 12162508</b>	
2	F954200210410	1	PLUG SCREW NOT NEEDED WITH AIR BRAKE	
3	F731200060160	1	SEALING WASHER NOT NEEDED WITH AIR BRAKE	DIN7603-14X18-CU-VERZ
4	F438200210380	1	COVER NOT NEEDED WITH AIR BRAKE	
6	F438200210220	2	HEXAGONAL HEAD BOLT	M10X16

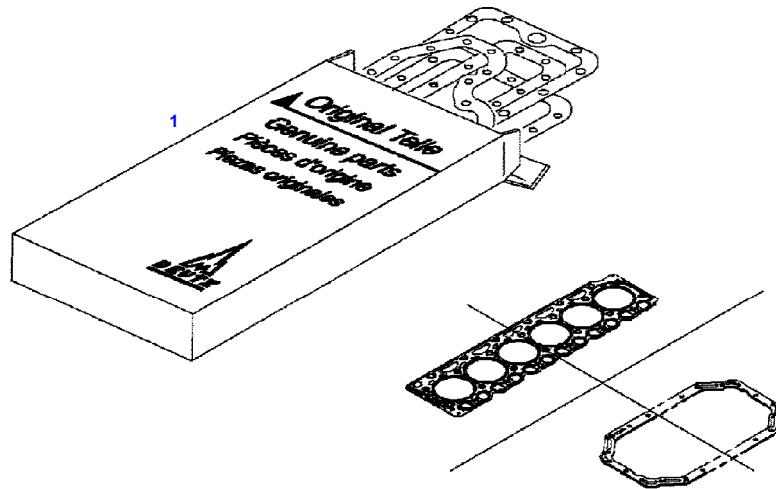

050910

---

Fendt

FENDT 930 S4 (NON SCR) (951/01001-05000) (WAM951XXX00F05001-99999)

F951003

SET OF GASKETS - MOTOR

Page01-0009

Item	Part Number	Qty	Description Comments
1	F954200210050	1	SEAL KIT WITHOUT CYLINDER HEAD GASKET WITHOUT SEAL OIL SUMP

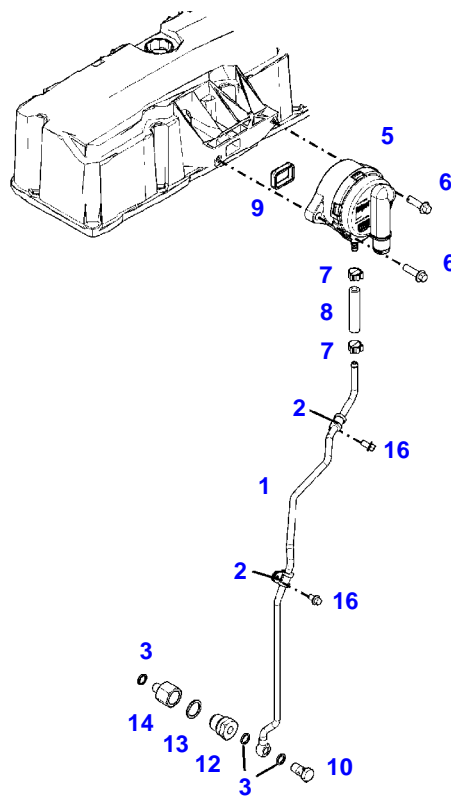

041330



## CRANKCASE BREATHER

Item	Part Number	Qty	Description Comments	Technical Specification
1	F946201210210	1	RETURN LINE ><2,3,10	
2	F934201210680	2	PIPE CLAMP	
3	X540003278000	3	SEALING WASHER	DIN 7603 A12X15,5-CU
5	F339202210280	1	BREATHER ><9	
6	F119200090080	2	HEXAGONAL HEAD BOLT M8X30	M8X30
7	F945201210020	2	HOSE CLIP	
8	F934201210110	1	RUBBER HOSE	
9	725200010251	1	SEAL	
10	F100001119241	1	BANJO BOLT	
12	F946201210140	1	LOCK VALVE ><13,14	
13	X540006678000	1	SEALING WASHER	DIN 7603 A22X27-CU
14	F934201210140	1	ADAPTER	
16	F119200090150	2	HEXAGONAL HEAD BOLT M6X12	M6X12

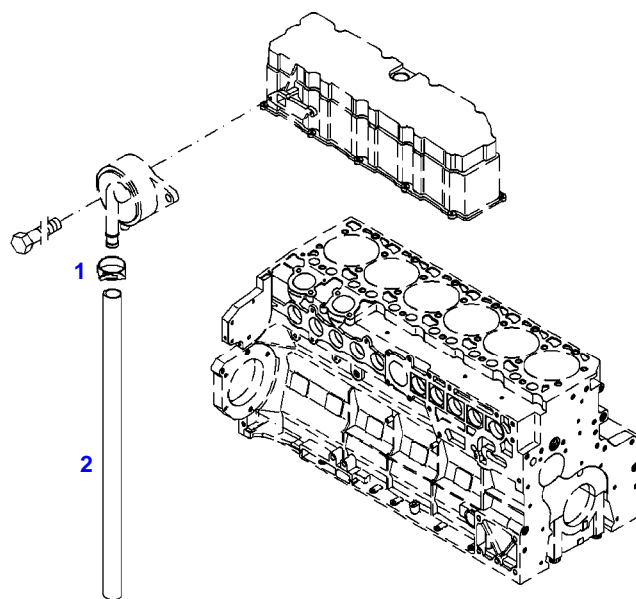

035675

Fendt

FENDT 930 S4 (NON SCR) (951/01001-05000) (WAM951XXX00F05001-99999)

F951003

CRANKCASE BREATHER

Page01-0011

Item	Part Number	Qty	Description Comments	Technical Specification
			<b>BREATHER TUBE</b>	
1	X458651300000	1	HOSE CLIP	
2	X591110000900	1	HOSE	L=900 DIN73411-22X3,5 R

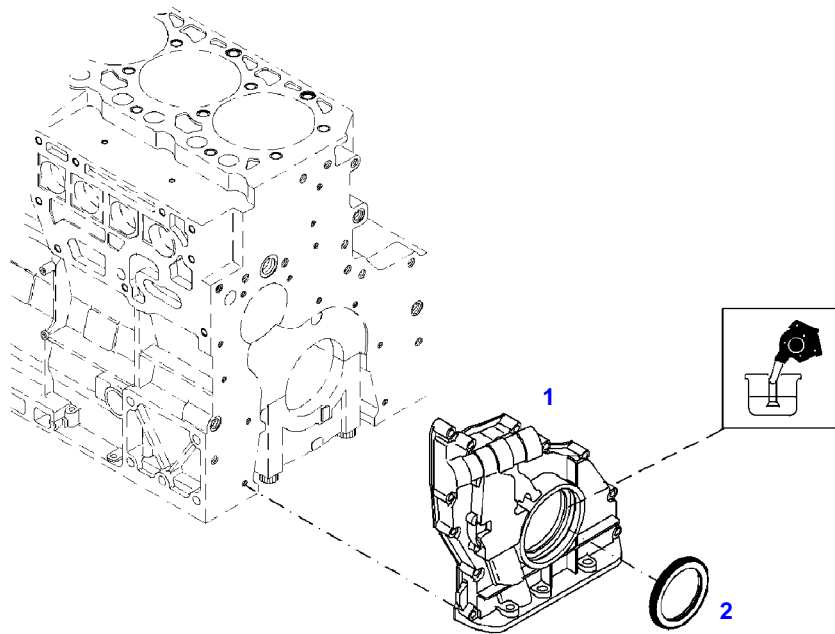

041280

---

Fendt

FENDT 930 S4 (NON SCR) (951/01001-05000) (WAM951XXX00F05001-99999)

F951003

FRONT COVER

Page01-0012

Item	Part Number	Qty	Description Comments
			<b>INTEGRATED OIL PUMP</b>
1	F946201210060	1	CRANKCASE END COVER ><2
2	F946201210070	1	SHAFT SEAL

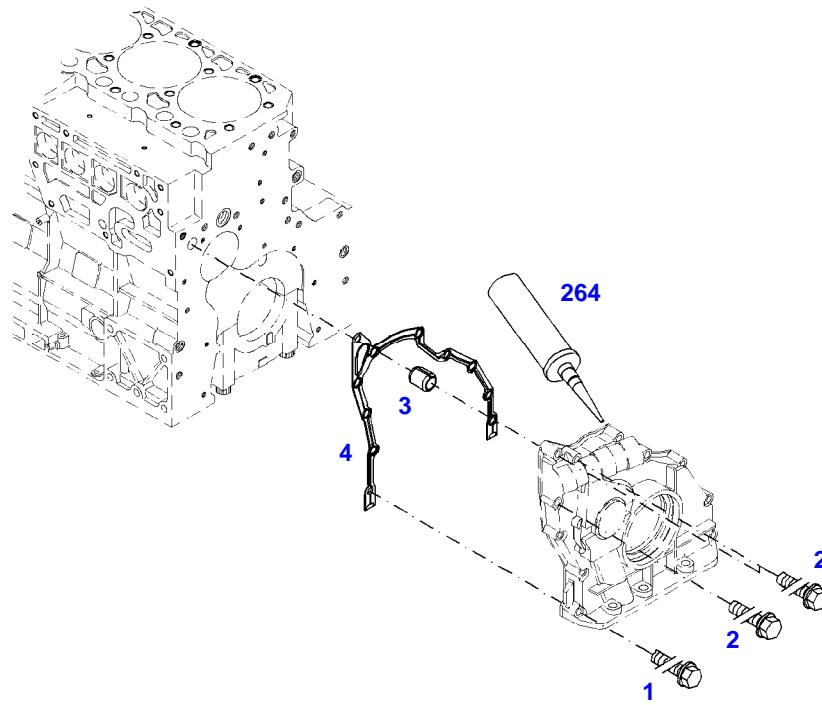

040931

Fendt

FENDT 930 S4 (NON SCR) (951/01001-05000) (WAM951XXX00F05001-99999)

F951003

FRONT COVER

Page01-0013

Item	Part Number	Qty	Description Comments	Technical Specification
<b>FASTENINGS</b>				
1	F416200210030	8	HEXAGONAL HEAD BOLT	M8X35
2	F934201210160	3	HEXAGONAL HEAD BOLT M8X70	
3	F119200210340	1	TENSIONER BUSH	
4	F934201210170	1	SEAL	
264	F934201210570	1	SEALING COMPOUND	

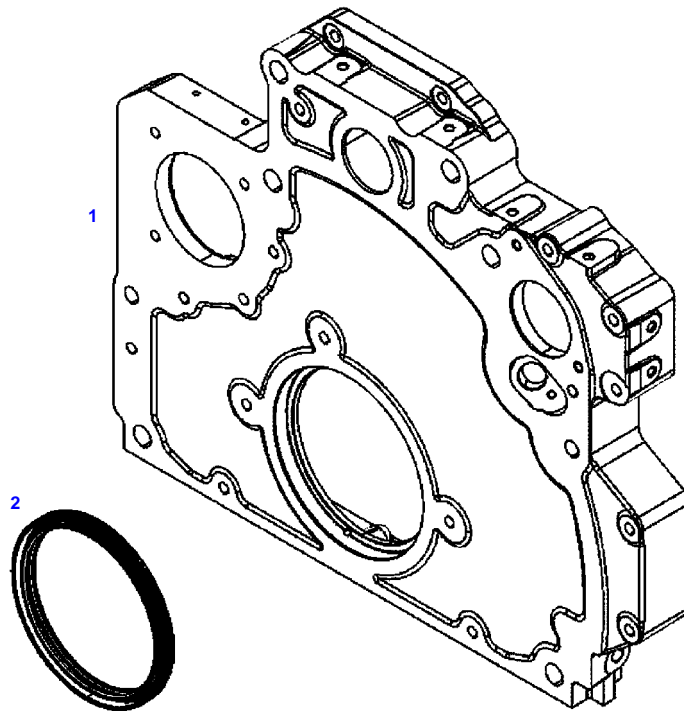

050911



---

Fendt

FENDT 930 S4 (NON SCR) (951/01001-05000) (WAM951XXX00F05001-99999)

F951003

GEARCASE

Page01-0014

Item	Part Number	Qty	Description Comments
1	F934201210840	1	WHEEL BOX
2	F946201210230	1	SHAFT SEAL

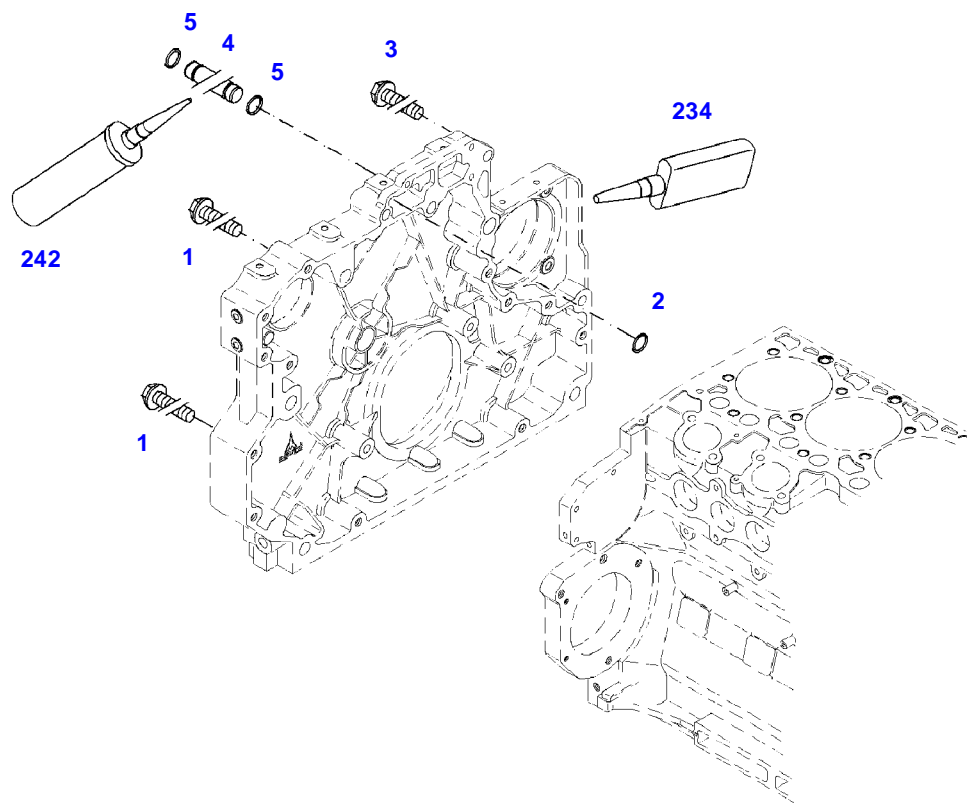

041039

Fendt

FENDT 930 S4 (NON SCR) (951/01001-05000) (WAM951XXX00F05001-99999)

F951003

GEARCASE

Page01-0015

Item	Part Number	Qty	Description Comments	Technical Specification
<b>FASTENINGS</b>				
1	F119200210750	8	HEXAGONAL HEAD BOLT M8X65	
2	F002200710040	1	SEAL 7X3MM	
3	F119200090080	2	HEXAGONAL HEAD BOLT M8X30	M8X30
4	F934201210190	1	BOLT ><5	
5	F934201210200	2	SEAL 42X4MM	
234	F119200210900	1	SEALING COMPOUND	
242	F119200040090	1	INSTALLATION AIDS	

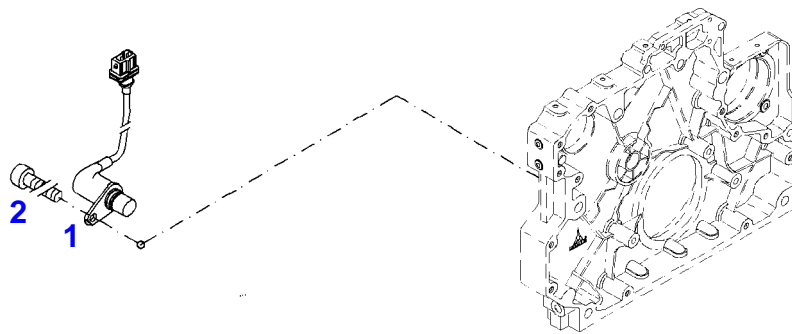

040932

Fendt

FENDT 930 S4 (NON SCR) (951/01001-05000) (WAM951XXX00F05001-99999)

F951003

IMPULSE TRANSMITTER

Page01-0016

Item	Part Number	Qty	Description Comments	Technical Specification
			<b>CAM SHAFT</b>	
1	F934201210210	1	ENGINE SPEED SENSOR CAM SHAFT	
2	X485004405000	1	SOCKET HEAD BOLT	DIN 912 M6X16-8.8

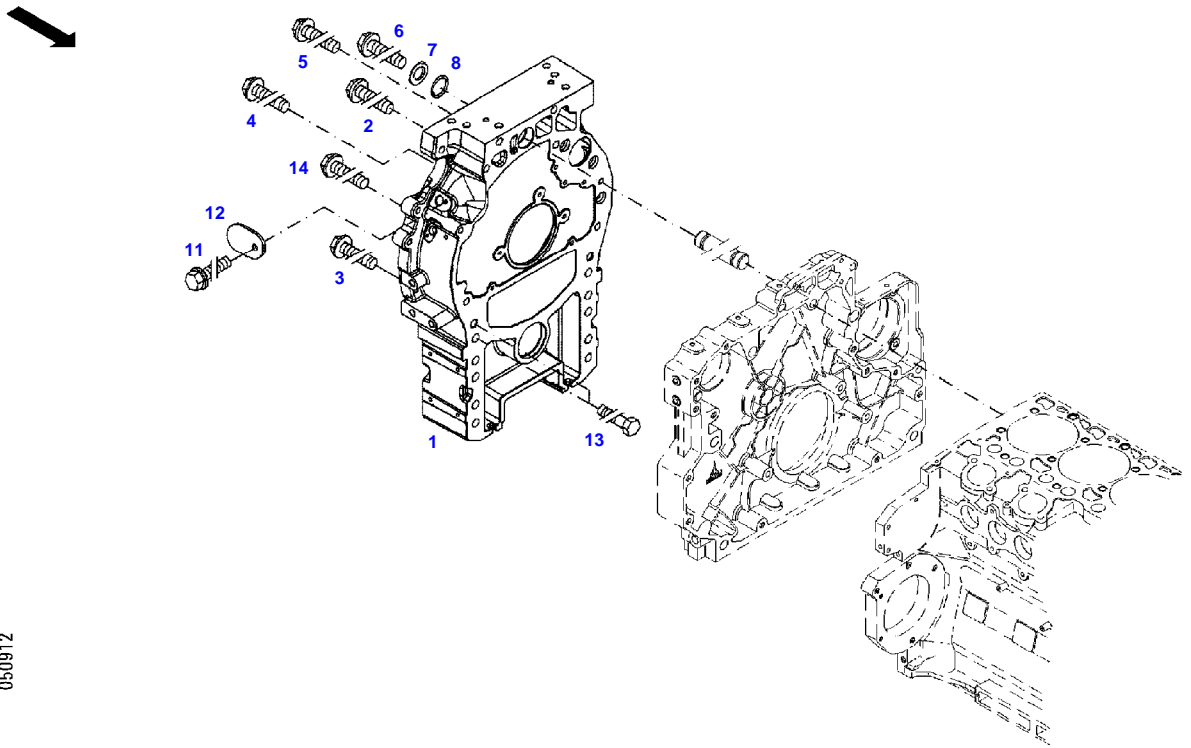

050912

## ADAPTER HOUSING

Item	Part Number	Qty	Description Comments	Technical Specification
1	F934201210620	1	CONNECTING HOUSING	
2	F934201210220	1	HEXAGONAL HEAD BOLT M16X200	
3	F934201210230	3	HEXAGONAL HEAD BOLT M16X120	
4	F934201210240	8	HEXAGONAL HEAD BOLT M8X70	
5	F934201210250	1	HEXAGONAL HEAD BOLT M12X130	
6	F934201210250	1	HEXAGONAL HEAD BOLT M16X1,5X180	
7	F934201210310	1	DISC	
8	F934201210270	1	SEAL 16X4MM	
11	F004200210700	1	HEXAGONAL HEAD BOLT M8X16	
12	F954200210060	1	LID	
13	X486555301000	2	HEXAGONAL HEAD BOLT	DIN 931 M20X70-10.9
14	F934201210290	1	HEXAGONAL HEAD BOLT M12X190	

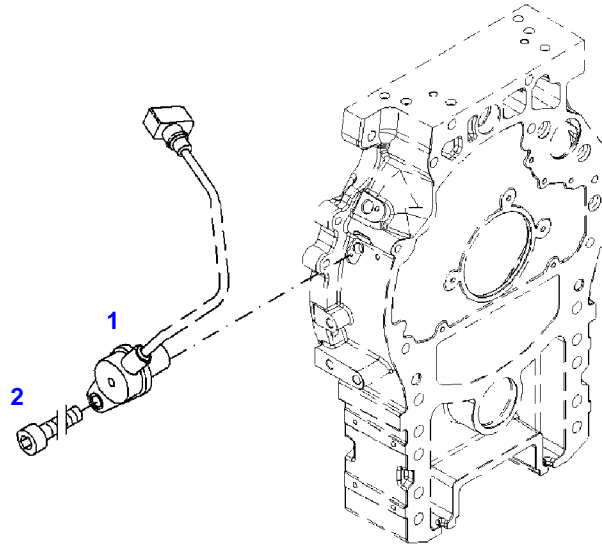

040934



Fendt

FENDT 930 S4 (NON SCR) (951/01001-05000) (WAM951XXX00F05001-99999)

F951003

IMPULSETRANSMITTER

Page01-0018

Item	Part Number	Qty	Description Comments	Technical Specification
			FLYWHEEL	
1	F339202210180	1	TRANSMITTER FLYWHEEL	
2	X485004405000	1	SOCKET HEAD BOLT	DIN 912 M6X16-8.8

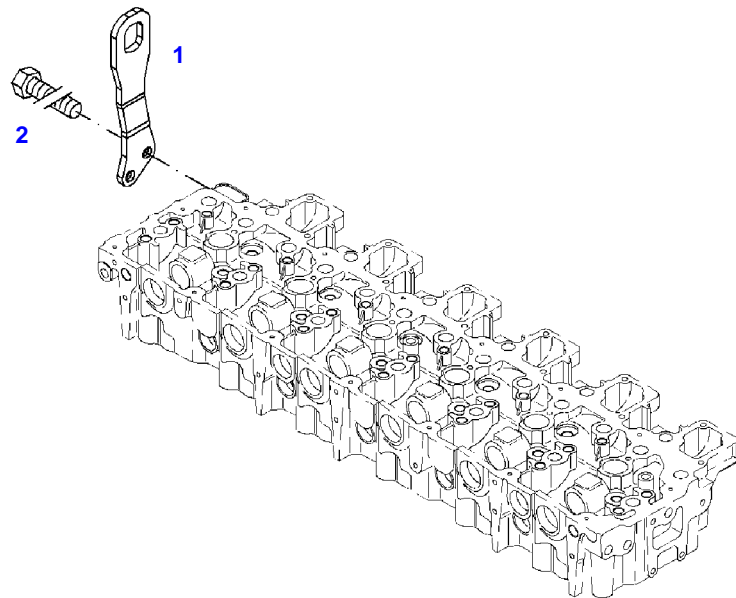

041281

---

Fendt

FENDT 930 S4 (NON SCR) (951/01001-05000) (WAM951XXX00F05001-99999)

F951003

ENGINE MOUNTING

Page01-0019

Item	Part Number	Qty	Description Comments
1	F946201210090	1	SUSPENSION PLATE
2	F946201210080	2	HEXAGONAL HEAD BOLT M12X25

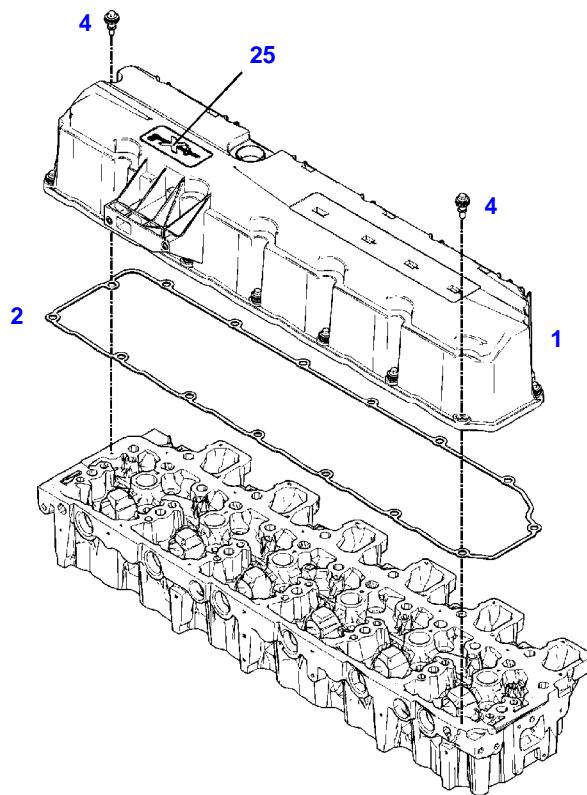

041388

Fendt

FENDT 930 S4 (NON SCR) (951/01001-05000) (WAM951XXX00F05001-99999)

F951003

VALVE COVER

Page01-0020

Item	Part Number	Qty	Description Comments
1	F934201210790	1	VALVE COVER ><2,4
2	F934201210010	1	SEAL
4	F934201210370	15	SCREW
25		1	NO SPARE PART

Thank you so much for reading.  
Please click the “Buy Now!”  
button below to download the  
complete manual.



After you pay.

You can download the most  
perfect and complete manual in  
the world immediately.

Our support email:

[ebooklibonline@outlook.com](mailto:ebooklibonline@outlook.com)