

SICKLE BAR

SB 1106

SB 1107



FRONTIER
EQUIPMENT



TABLE OF CONTENTS

Description		Service Machine Safely	
Description of the sickle bar	5	Practice safe maintenance.....	26
Assembly drawing	6	Wear appropriate clothing	26
		Stay clear of rotating drivelines	26
		Maintenance	26
Technical specification		Service	
Technical specification	7	Lubrication	28
Handling	7	Routine maintenance	28
		Every 2 work hours	28
Safety signs		Every 8 work hours	28
Safety-Alert symbol	8	Every 50 work hours	28
Identification machine	8	Periodically (6 months)	28
Machine safety labels	8	After each mowing job	28
		Cleaning and oiling the cutters	29
Machine safety labels and positions		Checking the clearance tolerance	29
Machine safety labels and positions	9	Storage	30
		Extra maintenance	31
Preparing the vehicle		Replacement of section-holding bar	31
Preparing the tractor	10	Replacement of sections	31
Park vehicle safety	10	Replacement of bar holding removable	
Stay clear of rotating drivelines	10	tooth	32
		Replacement of removable tooth	32
Installing		Replacement of belts	32
Installing sickle bar on tractor	10	Replacement of pulleys	32
PTO shaft adaption	12		
Stability of sickle bar and tractor during		Demolition and disposal	
transport	13	Demolition and disposal	33
Quick Coupler (optional)	14		
Park vehicle safety	14	Assembly	
Stay clear of rotating drivelines	14	Assembly	34
Removing		Transport on road	
Removing sickle bar	15	Transport on road	42
Removing sickle bar with Quick Coupler	15		
		Spare parts	
Operating		Spare parts	43
Operate safely	16		
Wear appropriate clothing	17	Decal kit and location	
Stay clear of rotating drivelines	17	Decal kit and location	54
Adapting the mowing bar	18		
Adjustment	19	Warranty	
Mowing	20	Warranty	56
Hazard bar	20	Warranty for replacement parts	57
Use of lifting device	22		
Mowing on flat ground	23		
Mowing on sloping ground	24		
Table approximate for choice of the			
cutting bar	25		

TO THE DEALER:

Assembly and proper installation of this product is the responsibility of the Frontier dealer. Read manual instruction and safety rules. Make sure all items on the Dealer's Pre-Delivery Check List in the Operator's Manual are completed before releasing equipment to the owner.

The dealer must complete the Warranty Registration, located on the Frontier website. **Warranty claims will be denied if the Warranty Registration has not been completed.**

TO THE OWNER:

Read this manual before operating your frontier equipment. The information presented will prepare you to do a better and a safer job. Keep this manual handy for ready reference. Require all operators to read this manual carefully and become acquainted with all the adjustment and operating procedures before attempting to operate. Replacement manuals can be obtained from your selling dealer.

The equipment you have purchased has been carefully engineered and manufactured to provide dependable and satisfactory use. Like all mechanical products, it will require cleaning and upkeep. Lubricate the unit as specified. Observe all safety information in this manual and safety decals on the equipment.

For service, your authorized Frontier dealer has trained mechanics, genuine Frontier service parts, and the necessary tools and equipment to handle all your needs.

Use only genuine Frontier service parts. Substitute parts will void the warranty and may not meet standards required for safe and satisfactory operation. Record the model number and serial number of your equipment in the spaces provided:

Model: _____ **Date of Purchase** _____

Serial Number: (see Safety Decal section for location) _____

Provide this information to your dealer to obtain correct repair parts.

Throughout this manual, the term **IMPORTANT** is used to indicate that failure to observe can cause damage to equipment. The terms **CAUTION**, **WARNING** and **DANGER** are used in conjunction with the Safety-Alert Symbol, (a triangle with an exclamation mark), to indicate the degree of hazard for items of personal safety.



This Safety-Alert Symbol indicates a hazard and means **ATTENTION! BECOME ALERT! YOUR SAFETY IS INVOLVED!**



Indicates an imminently hazardous situation that, if not avoided, will result in death or serious injury.



WARNING

Indicates a potentially hazardous situation that, if not avoided, could result in death or serious injury, and includes hazards that are exposed when guards are removed.



CAUTION

Indicates a potentially hazardous situation that, if not avoided, may result in minor or moderate injury.

IMPORTANT

Indicates that a failure to observe can cause damage to equipment.

NOTE

Indicates helpful information.

DESCRIPTION

Description of the sickle bar

This agricultural implement can only operate by means of a cardan shaft applied to the pto of an agricultural tractor equipped with lift and universal three-point hitch. Since it is movable, the mowing machine can be easily mounted on tractors with different gauges or on tracked vehicles (Fig. 1). The two-motion tooth-blade system used in mowing machines, makes possible a scissors cut which leads to a high speed operation on any crop. The original tooth-blade motion guarantees a sharp and clean cut on any type of grass, be it damp or flattened. It is thanks to the total absence of soil which this mowing system does not raise, sharp because the stems are not frayed. The sickle bar may also be used with the cutting arm tilted for working on canals, ditches and embankments (Fig. 2 and 3).



ATTENTION

The sickle bar is suitable only for the uses indicated. Any other use different from that described in these instructions could cause damage to the machine and represent a serious hazard for the user.

It is therefore advisable to strictly comply with the following instructions in order to prevent faults which could jeopardize the correct and long-lasting operation of the implement. Compliance with the instructions in this handbook is also important since **the Manufacturer declines all and every responsibility for damage to persons or property caused by negligence and failure to comply with these instructions.**

The Manufacturer shall, however, remain at the customers' disposal for immediate and thorough assistance together with anything else that may be required in order to ensure the correct operation and maximum efficiency of the implement.

The Manufacturer reserves the right to make any modifications and improvements to the implement as may be considered opportune, without being obliged to immediately inform the user.

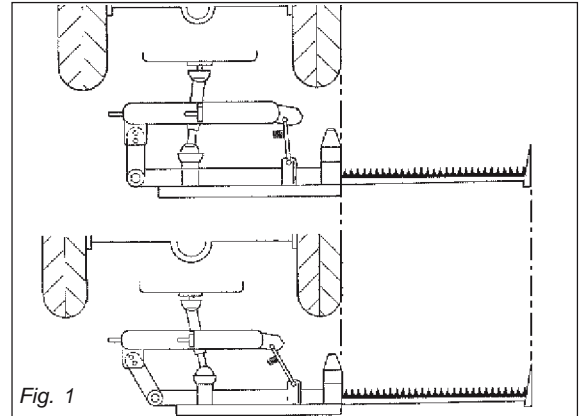

Fig. 1

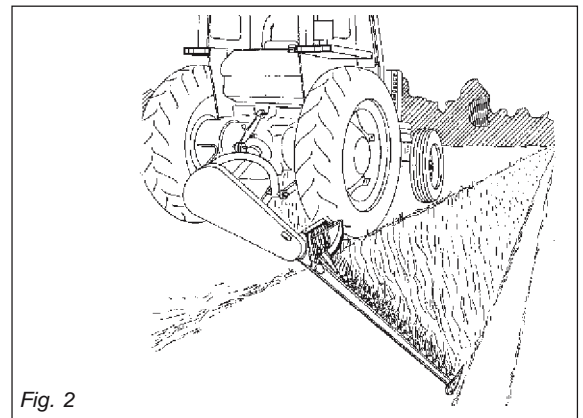

Fig. 2

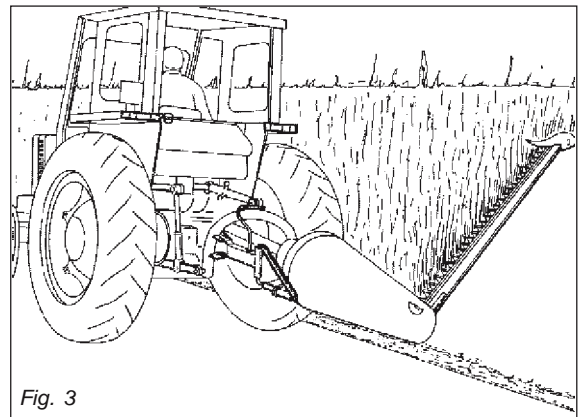

Fig. 3

DESCRIPTION

Assembly drawing

- 1 External shoe;
- 2 Mowing guide;
- 3 Cutting arm;
- 4 Upper 3rd point hitches;
- 5 Gauge varying articulation;
- 6 Chassis;
- 7 Tirant;
- 8 Lower 3rd point hitches;
- 9 Hazard bar;
- 10 Support;
- 11 Identification label;
- 12 Cover;
- 13 Protective casing for connecting-rod systems;
- 14 Support;
- 15 Hinge (pivot point);
- 16 Blade guard;
- 17 PTO.

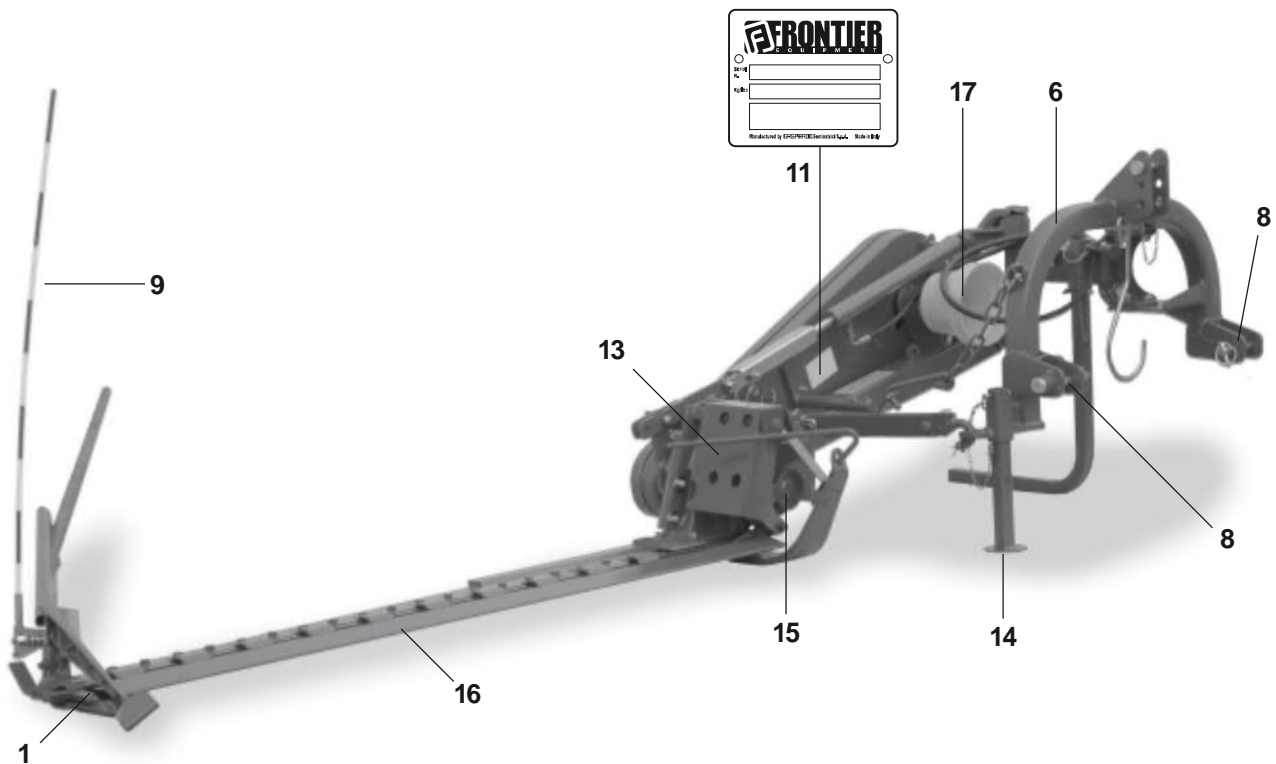
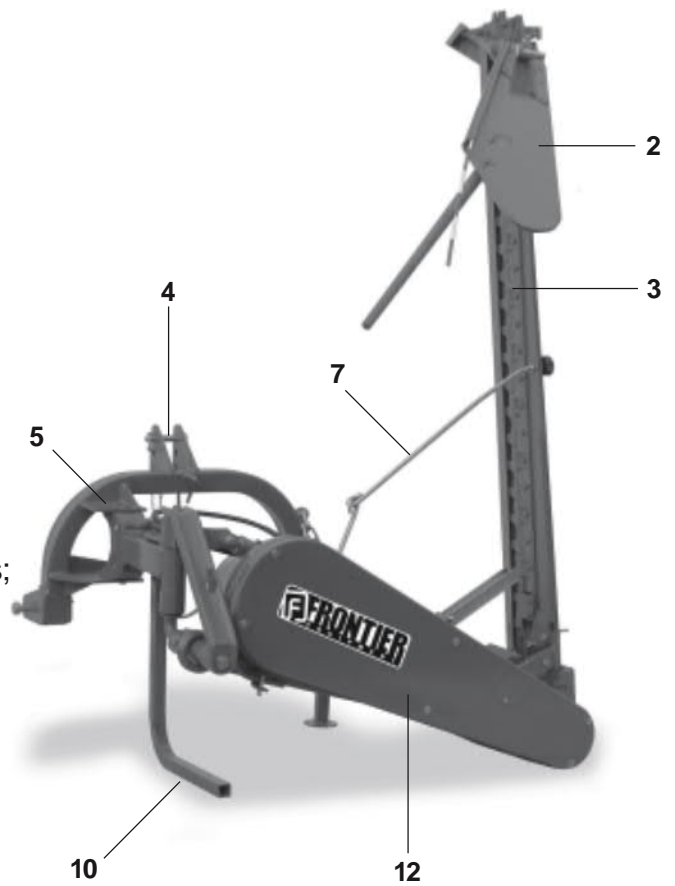

Fig. 4

Thank you so much for reading.
Please click the “Buy Now!”
button below to download the
complete manual.



After you pay.

You can download the most
perfect and complete manual in
the world immediately.

Our support email:

ebooklibonline@outlook.com