

Manual No. EM8RA-2-2

# Operator's Manual

***EH5000ACII***

**Rigid Dump Truck**

Serial No.  
EH5000ACII

8RAAB: 8RAABN00001006 and Up

**HITACHI**

# INDEX

MACHINE NUMBERS

SAFETY

SAFETY SIGNS

COMPONENTS NAME

OPERATOR'S STATION

BREAK-IN

OPERATING THE RIGID DUMP TRUCK

OPERATING METHODS

TRANSPORTING

MAINTENANCE

STORAGE

TROUBLESHOOTING

SPECIFICATIONS

OPTIONS

INFORMATION FEEDBACK FORM

ALPHABETICAL INDEX

# CONTENTS

## INTRODUCTION

## INDEX

## MACHINE NUMBERS

RIGID DUMP TRUCK TYPE AND SERIAL NUMBER.....	M-1
ROLLOVER PROTECTIVE STRUCTURE NAMEPLATE .....	M-1
FRAME PRODUCT IDENTIFICATION NUMBER .....	M-2
MTU DETROIT DIESEL DATA TAG.....	M-2
LEFT WHEEL MOTOR DATA TAG.....	M-3
RIGHT WHEEL MOTOR DATA TAG.....	M-3
LEFT SPINDLE ASSEMBLY DATA TAG .....	M-3
RIGHT SPINDLE ASSEMBLY DATA TAG.....	M-3
TRACTION ALTERNATOR DATA TAG .....	M-4
TRACTION CONTROL CABINET DATA TAG .....	M-4

## SAFETY

RECOGNIZE SAFETY INFORMATION .....	S-1
UNDERSTAND SIGNAL WORD .....	S-1
OPERATOR'S QUALIFICATIONS.....	S-2
DUTIES OF THE OPERATOR .....	S-2
INSPECT RIGID DUMP TRUCK .....	S-2
FOLLOW SAFETY INSTRUCTIONS.....	S-3
PREPARE FOR EMERGENCIES.....	S-3
WEAR PROTECTIVE CLOTHING.....	S-4
PROTECT AGAINST NOISE .....	S-4
PROTECT AGAINST FLYING DEBRIS.....	S-4
GENERAL PRECAUTIONS FOR CAB.....	S-5
USE HANDHOLDS AND STEPS.....	S-6
ADJUST THE OPERATOR'S SEAT .....	S-6
FASTEN YOUR SEAT BELT .....	S-7
HANDLE STARTING AIDS SAFELY .....	S-7
OPERATE ONLY FROM OPERATOR'S SEAT .....	S-8
JUMP STARTING .....	S-8
KEEP RIDERS OFF RIGID DUMP TRUCK... ..	S-8
PROTECT AGAINST FALLING STONES .....	S-9
PROVIDE SIGNALS FOR JOBS .....	S-9
OPERATE THE RIGID DUMP TRUCK SAFELY .....	S-10
AVOID INJURY FROM RUNNING OVER CRUSH AREA.....	S-11
AVOID TIPPING.....	S-12
AVOID INJURY FROM ROLLAWAY .....	S-13
NEVER TRAVEL WITH BODY OFF THE FRAME .....	S-13
OPERATING WITH THE RIGID DUMP TRUCK NEAR OVERHEAD WIRES.....	S-14
OPERATING WITH THE RIGID DUMP TRUCK NEAR HIGH VOLTAGE OVERHEAD POWER LINES.....	S-14
PARK RIGID DUMP TRUCK SAFELY .....	S-15
SAFE HANDLING OF OFF ROAD TIRES... ..	S-16

DISCHARGE ACCUMULATORS .....	S-16
HANDLE FLUIDS SAFELY AVOID FIRES.. ..	S-17
A FEW SIMPLE RULES WHEN SERVICING .....	S-18
USE TOOLS PROPERLY.....	S-20
PREVENT BURNS .....	S-21
REPLACE RUBBER HOSES PERIODICALLY.....	S-21
AVOID HIGH-PRESSURE FLUIDS.....	S-22
FIRE PREVENTION MEASURES.....	S-23
EVACUATING IN CASE OF FIRE.....	S-25
BEWARE OF EXHAUST FUMES.....	S-25
PRECAUTIONS FOR WELDING, CUTTING, AND GRINDING .....	S-26
REMOVE PAINT BEFORE WELDING OR CUTTING.....	S-26
AVOID HEATING NEAR PRESSURIZED FLUID LINES .....	S-27
AVOID APPLYING HEAT TO LINES CONTAINING FLAMMABLE FLUIDS.....	S-27
PREVENT BATTERY EXPLOSIONS .....	S-28
SERVICE AIR CONDITIONING SYSTEM SAFELY .....	S-38
HANDLE CHEMICAL PRODUCTS SAFELY.....	S-29
DISPOSE OF WASTE PROPERLY .....	S-29
MEMO .....	S-30

## SAFETY SIGNS

VISIBILITY FRONT.....	SS-5
SAFETY RADIATOR .....	SS-5
NO JUMP START .....	SS-5
FAN BLADE .....	SS-5
HIGH VOLTAGE .....	SS-6
TIRE SIZE .....	SS-6
GROSS MACHINE WEIGHT .....	SS-6
RETARDER DECAL .....	SS-6
FORWARD & REVERSE PROPULSION INHIBIT .....	SS-7
READ & UNDERSTAND OPERATOR'S MANUAL .....	SS-7
HIGH PRESSURE .....	SS-7
BODY DOWN .....	SS-7
VISIBILITY REAR .....	SS-8
BODY LOCK POSITION.....	SS-8
FOUR POINT LIFT .....	SS-8
NO TOWING.....	SS-8
OVERHEAD LOAD .....	SS-9
CRUSH AREA .....	SS-9
BATTERY DISCONNECT .....	SS-9
EMERGENCY ENGINE SHUTDOWN.....	SS-9
PLANETARY LUBRICANT LEVEL.....	SS-10
MAINTENANCE FREE BATTERY .....	SS-10
LOCK BODY .....	SS-10
CONTENTS UNDER PRESSURE .....	SS-10
DO NOT LIFT.....	SS-11
FASTEN THE SEAT BELT .....	SS-11
AVOID EXHAUST FUMES .....	SS-11
PEDAL LOCATION.....	SS-11

# CONTENTS

---

DISCHARGE ACCUMULATORS ..... SS-12

## COMPONENTS NAME

COMPONENTS NAME ..... 1-1

## OPERATOR'S STATION

CAB FEATURES ..... 2-1  
DASH CONTROLS ..... 2-2  
HITACHI LCD MONITOR ..... 2-9  
IDU CONTROL PAD ..... 2-15  
WINDSHIELD WASHER & WIPER ..... 2-16  
RHEOSTAT, INSTRUMENT LIGHTING ..... 2-16  
IGNITION SWITCH ..... 2-16  
CAMERA MONITOR ..... 2-17  
EMERGENCY ENGINE SHUTDOWN ..... 2-18  
DC DRIVE SHUT DOWN SWITCH ..... 2-18  
DATA STORE SWITCH ..... 2-18  
AUXILIARY OUTLET ..... 2-18  
A/C & HEATER CONTROL ..... 2-19  
ENGINE LAMPS ..... 2-19  
DIAGNOSTIC CENTER ..... 2-19  
MP3 JACK ..... 2-20  
CRUISE CONTROL ON/OFF SWITCH ..... 2-20  
CRUISE CONTROL SWITCH ..... 2-20  
PARK BRAKE SWITCH ..... 2-21  
HEADLAMP SWITCH ..... 2-21  
STAIRWAY AND DECK LAMP SWITCH ..... 2-21  
AUDIBLE ALARM CANCEL SWITCH ..... 2-22  
GRID DRY SWITCH ..... 2-22  
MP3/CD PLAYER RADIO ..... 2-23  
RHEOSTAT, LCD MONITOR ..... 2-24  
POWER WINDOW SWITCHES ..... 2-24  
LOAD/DUMP BRAKE SWITCH ..... 2-24  
PROPULSION OVERRIDE ..... 2-25  
CONTROL, A/C AND HEATER ..... 2-26  
DIRECTIONAL RANGE SELECTOR ..... 2-29  
STEERING COLUMN CONTROLS ..... 2-30  
FOOT CONTROLS ..... 2-33  
OPERATOR'S SEAT ADJUSTMENT ..... 2-34  
SEAT CONTROLS ..... 2-35  
CAB REAR COMPONENT LAYOUT ..... 2-38  
REMOTE MOUNTED CONTROLS ..... 2-39  
RIGID DUMP TRUCK LOADING POLICY ..... 2-42  
HAUL CYCLE DATA ..... 2-45

## BREAK-IN

OBSERVE RIGID DUMP TRUCK  
CLOSELY ..... 3-1

## OPERATING THE RIGID DUMP TRUCK

INSPECT RIGID DUMP TRUCK  
DAILY BEFORE STARTING ..... 4-1  
PRE-OPERATION INSPECTION ..... 4-2  
OIL AND WATER LEAKS ..... 4-4  
CHECK INSTRUMENTS & CONTROLS  
BEFORE STARTING ..... 4-5  
COOLANT LEVEL CHECK ..... 4-5

STARTING ENGINE ..... 4-6  
USING BOOSTER BATTERIES ..... 4-9  
SUPPLEMENTAL STEERING & BRAKE  
OPERATIONAL TEST ..... 4-11  
LOADING ..... 4-12  
PAYLOAD MONITORING ..... 4-13  
HAULING ..... 4-17  
DUMPING ..... 4-18  
STOPPING ..... 4-21  
ANTI-ROLL PROTECTION ..... 4-21  
STOPPING THE ENGINE ..... 4-22

## OPERATING METHODS

GENERAL INFORMATION ..... 5-1  
COOLING A HOT ENGINE ..... 5-2  
SHIFTING DIRECTIONAL RANGE  
SELECTOR ..... 5-2  
ACCELERATOR PEDAL ..... 5-3  
STEERING ..... 5-3  
CRUISE CONTROL ..... 5-4  
DYNAMIC RETARDER ..... 5-4  
RETARDER OPERATION DECAL ..... 5-5  
SERVICE BRAKES ..... 5-7  
PARKING BRAKE ..... 5-7  
LOAD/DUMP BRAKE SWITCH ..... 5-8  
OPERATING THE HOIST CONTROL  
LEVER ..... 5-9  
RIGID DUMP TRUCK STUCK IN DEEP  
SAND, SNOW OR MUD ..... 5-13  
COLD WEATHER RESTRICTIONS ..... 5-13  
TOWING ..... 5-14  
PARKING RIGID DUMP TRUCK ..... 5-17

## TRANSPORTING THE RIGID DUMP TRUCK

TRANSPORTING ..... 6-1

## MAINTENANCE

CORRECT MAINTENANCE AND  
INSPECTION PROCEDURES ..... 7-1  
WASHING RIGID DUMP TRUCK ..... 7-1  
SERVICE RIGID DUMP TRUCK AT  
SPECIFIED INTERVALS ..... 7-2  
RECOMMENDED LUBRICANTS ..... 7-3  
RECOMMENDED FUEL ..... 7-8  
PREPARE RIGID DUMP TRUCK FOR  
SERVICE ..... 7-9  
INSTALLING BODY PROP PINS ..... 7-10  
REMOVAL AND STORAGE OF  
BODY PROP PINS ..... 7-11  
ELECTRICAL DISCONNECTS BEFORE  
WELDING ON THE RIGID DUMP  
TRUCK ..... 7-12  
MAINTENANCE INTERVAL GUIDE ..... 7-14  
A. GREASING ..... 7-22  
B. ENGINE ..... 7-25  
C. POWER TRANSMISSION ..... 7-30

---

# CONTENTS

---

D. HYDRAULIC STEERING/BRAKE	
APPLY SYSTEM.....	7-33
E. HYDRAULIC HOIST/BRAKE	
COOLING SYSTEM.....	7-39
F. BRAKES SERVICE AND PARKING.....	7-44
G. FUEL SYSTEM .....	7-47
H. AIR CLEANER.....	7-50
I. COOLING SYSTEM.....	7-55
J. ELECTRICAL SYSTEM .....	7-64
K. SUSPENSION WHEELS	
AND TIRES .....	7-79
L. CAB.....	7-84
M. GENERAL .....	7-90
MAINTENANCE OF OPTIONAL	
SYSTEMS .....	7-94

## STORAGE

SHORT TERM STORAGE.....	8-1
MODERATE TERM STORAGE.....	8-3
LONG TERM STORAGE .....	8-5
OTHER CHECKS AND SERVICE .....	8-8
RETURN TO SERVICE .....	8-9

## TROUBLESHOOTING

ENGINE .....	9-1
ENGINE COOLING.....	9-4
STARTER AND MOUNTING .....	9-4
AIR CLEANER .....	9-5
ELECTRICAL SYSTEM .....	9-6
HYDRAULIC SYSTEM.....	9-9
HYDRAULIC HOIST SYSTEM .....	9-11
HYDRAULIC STEER SYSTEM .....	9-12
STEERING PUMP .....	9-13
STEERING CONTROL VALVE .....	9-14
FRONT AXLE.....	9-16
REAR AXLE .....	9-17
HOIST PUMP DRIVELINE.....	9-18
REAR AXLE PLANETARY .....	9-18
PARKING BRAKE.....	9-19

## SPECIFICATIONS

SERVICE SPECIFICATIONS	
EH5000ACII .....	10-1
MACHINE DIMENSIONS.....	10-8
PERFORMANCE/RETARDER CHARTS ...	10-10

## OPTIONS

OPTIONS .....	11-1
---------------	------

## INFORMATION FEEDBACK FORM

INFORMATION FEEDBACK FORM.....	12-1
--------------------------------	------

## INDEX

ALPHABETICAL INDEX .....	13-1
--------------------------	------

---



# MACHINE NUMBERS

The numbers asked for in this section are the individual numbers; model, product identification, serial, type and manufacturer given to each machine and major components. These numbers are requested when inquiring about replacement parts or machine service. Fill in the blank spaces in this section to immediately have them available upon request.

## MACHINE TYPE AND SERIAL NUMBER

PRODUCT  
MODEL  
NUMBER: \_\_\_\_\_

PRODUCT  
IDENTIFICATION  
NUMBER: \_\_\_\_\_

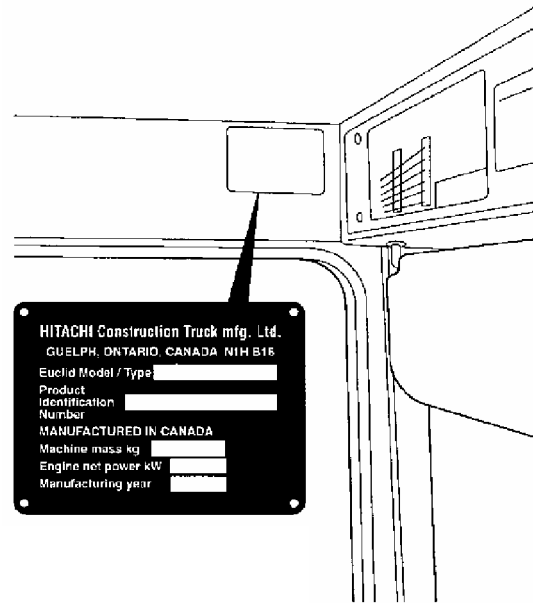

EL20456

## ROLLOVER PROTECTIVE STRUCTURE NAMEPLATE

HITACHI  
MODEL  
TYPE: \_\_\_\_\_

ROPS  
MODEL  
NUMBER: \_\_\_\_\_

MAX  
MACHINE  
MASS, M-kg: \_\_\_\_\_

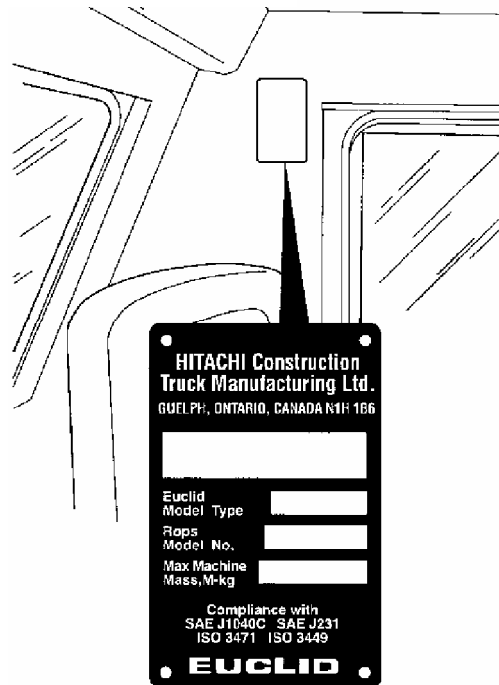

EL20475

# MACHINE NUMBERS

---

**FRAME PRODUCT IDENTIFICATION NUMBER**

\_\_\_\_\_

\_\_\_\_\_

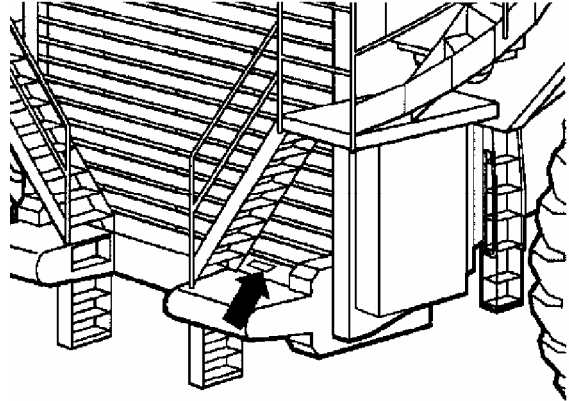

EL20210

**MTU DETROIT DIESEL DATA TAG**

TYPE: \_\_\_\_\_

MFG. NO.: \_\_\_\_\_

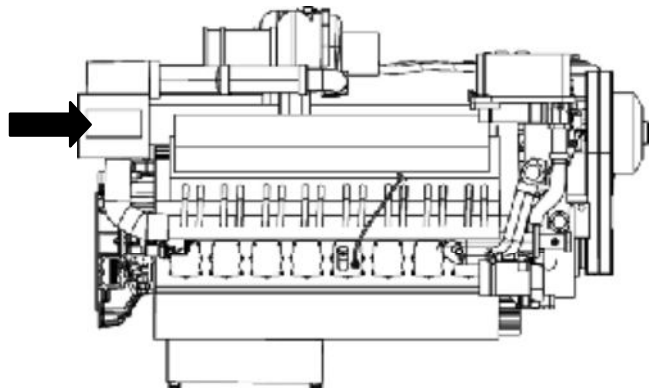



# MACHINE NUMBERS

---

## LEFT WHEEL MOTOR DATA TAG

TYPE: \_\_\_\_\_

MFG. NO.: \_\_\_\_\_

## RIGHT WHEEL MOTOR DATA TAG

TYPE: \_\_\_\_\_

MFG. NO.: \_\_\_\_\_

## LEFT SPINDLE ASSEMBLY DATA TAG

TYPE: \_\_\_\_\_

MFG. NO.: \_\_\_\_\_

## RIGHT SPINDLE ASSEMBLY DATA TAG

TYPE: \_\_\_\_\_

MFG. NO.: \_\_\_\_\_

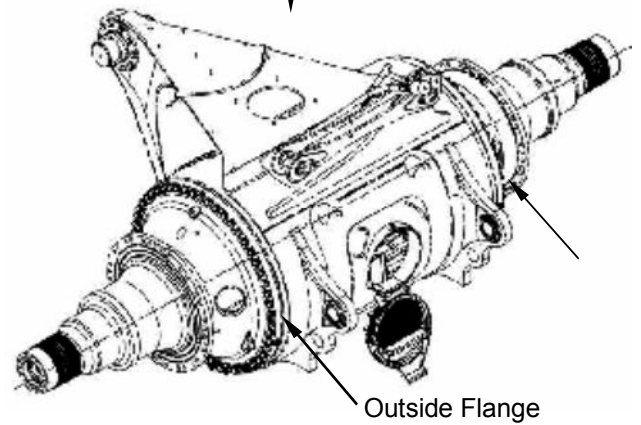
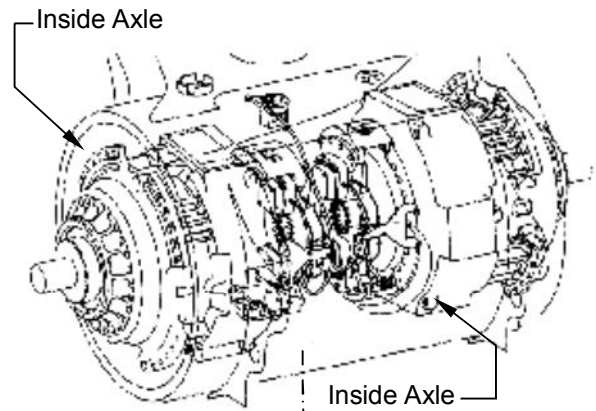

# MACHINE NUMBERS

---

## TRACTION ALTERNATOR DATA TAG

TYPE: \_\_\_\_\_

MFG. NO.: \_\_\_\_\_

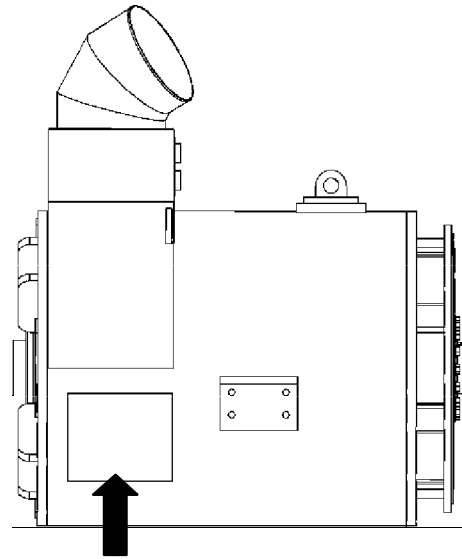

## TRACTION CONTROL CABINET DATA TAG

TYPE: \_\_\_\_\_

MFG. NO.: \_\_\_\_\_

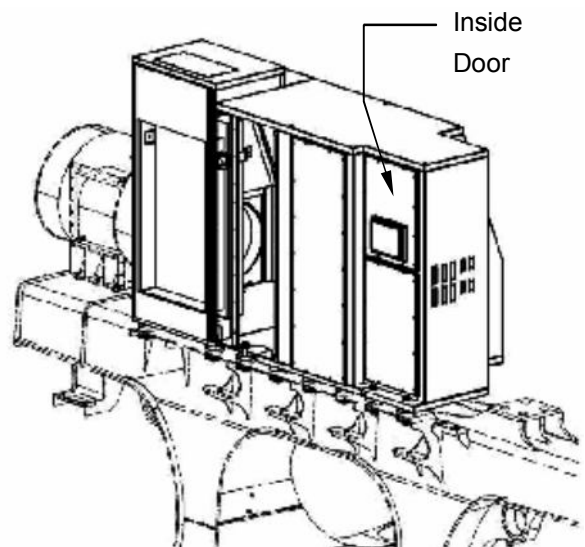

# SAFETY

---

## RECOGNIZE SAFETY INFORMATION

### • SAFETY ALERT SYMBOL

- This symbol, which will appear at various points in the manual and on the rigid dump truck together with a warning statement, means: **“Warning, be alert! Your safety is involved!” Carefully read the message that follows. It is the obligation of the operator to make sure that all warning decals are in place on the rigid dump truck and that they are readable. Accidents may otherwise occur.**
- Follow recommended precautions and safe operating practices.
- Every country (Jurisdiction) has its own safety regulations. It is the obligation of the operator to know and follow these. This also applies to local regulations covering different types of work. Should the recommendations in this manual deviate from those of your country (Jurisdiction), your local safety regulations should be followed.

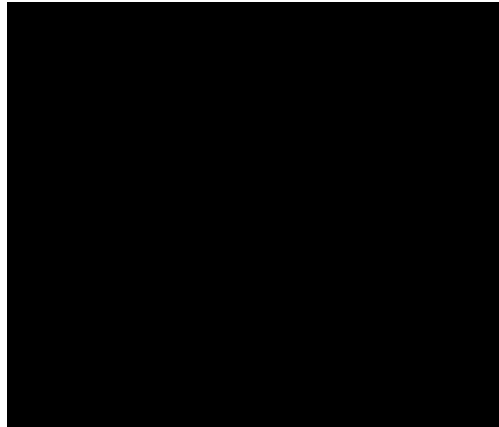

---

## UNDERSTAND SIGNAL WORD

- On the rigid dump truck safety signs, signal words designating the degree or level of hazard – DANGER, WARNING, or CAUTION – are used with the safety alert symbol.
  - **DANGER** indicates an imminently hazardous situation which, if not avoided, will result in death or serious injury.
  - **WARNING** indicates a potential hazardous situation which, if not avoided, could result in death or serious injury.
  - **CAUTION** indicates a potentially hazardous situation which, if not avoided, may result in minor or moderate injury.
  - **DANGER or WARNING safety signs** are located near specific hazards. General precautions are listed on **CAUTION safety signs**.
- These signal words also call attention to safety messages in this manual.
- To avoid confusing rigid dump truck protection with personal safety messages, a signal word **IMPORTANT** indicates a situation which, if not avoided, could result in damage to the rigid dump truck.

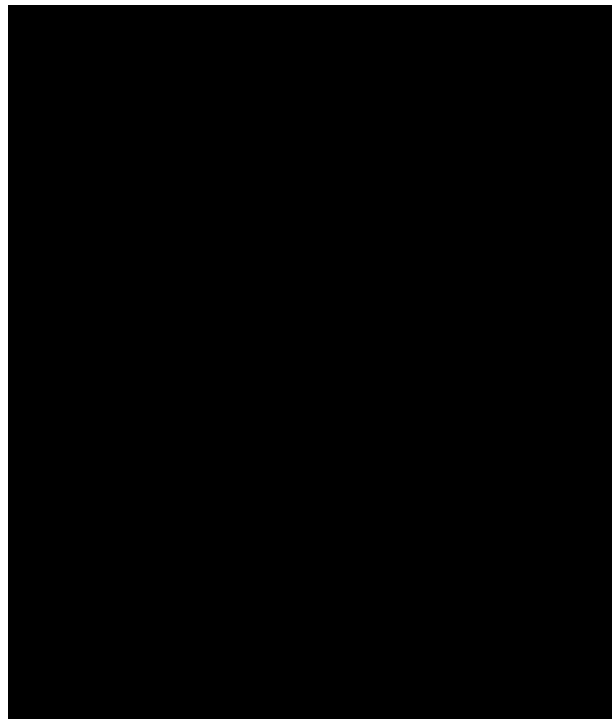

■ **NOTE:** indicates an additional explanation for an element of information.

# SAFETY

---

## OPERATOR'S QUALIFICATIONS

- Only trained personnel should operate the rigid dump truck.
- Operator should be of legal rigid dump truck operating age according to country (Jurisdiction) regulations and familiar with the operation and maintenance of the rigid dump truck.
- Operator must be licensed if required by National Rules and Regulations.

## DUTIES OF THE OPERATOR

- Before you operate the rigid dump truck, this manual must be read and understood. Contact your supervisor if you do not understand any portion of this manual. By reading and understanding the manual, you will become aware of and observe how to avoid injury and damage.
- Know the work area and the company rules and regulations
- Never operate the rigid dump truck while under the influence of alcohol, medicine or other drugs.

Due to the position of the cab and size of the rigid dump truck, the operator has limited visibility to areas close to or near the rigid dump truck. No person should enter the operating area of the rigid dump truck when it is in operation without first notifying the operator. If a person has to enter the operating area of the rigid dump truck, they should signal the operator and wait for an acknowledgement of recognition by the operator.

During rigid dump truck operation no one should be allowed to get any closer than 7m (23 ft.) of the rigid dump truck. Any closer will limit one's time to react and move away from the vehicle when it starts.

---

## INSPECT RIGID DUMP TRUCK

- Inspect your rigid dump truck carefully each day or shift by walking around it before you start it to avoid personal injury.
- Be sure to cover all points described under "INSPECT RIGID DUMP TRUCK DAILY BEFORE STARTING" found in the **OPERATING THE ENGINE** section in this operator's manual.

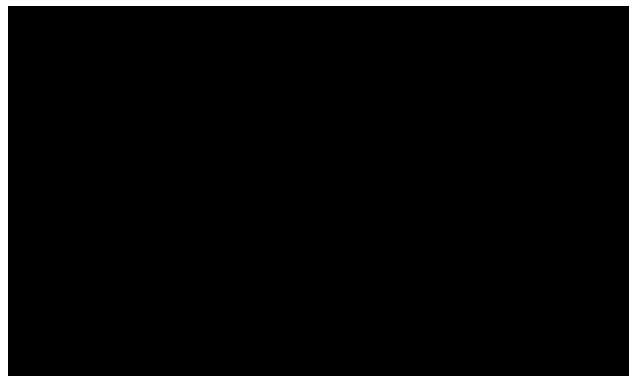

SA-435

# SAFETY

---

## FOLLOW SAFETY INSTRUCTIONS

- Carefully read and follow all safety signs on the rigid dump truck and all safety messages in this manual.
- Safety signs should be installed, maintained and replaced when necessary.
  - If a safety sign or this manual is damaged or missing, order a replacement from your authorized Hitachi dealer in the same way you order other replacement parts (be sure to state rigid dump truck model and serial number when ordering).
- Learn how to operate the rigid dump truck and its controls correctly and safely.
- Allow only trained qualified, authorized personnel to operate the rigid dump truck.
- Keep your rigid dump truck in proper working condition.
  - Unauthorized modifications of the rigid dump truck may impair its function and/or safety and affect rigid dump truck life.
- The safety messages in this SAFETY chapter are intended to illustrate basic safety procedures of rigid dump trucks. However it is impossible for these safety messages to cover every hazardous situation you may encounter. If you have any questions, you should first consult your supervisor and/or your authorized Hitachi dealer before operating or performing maintenance work on the rigid dump truck.

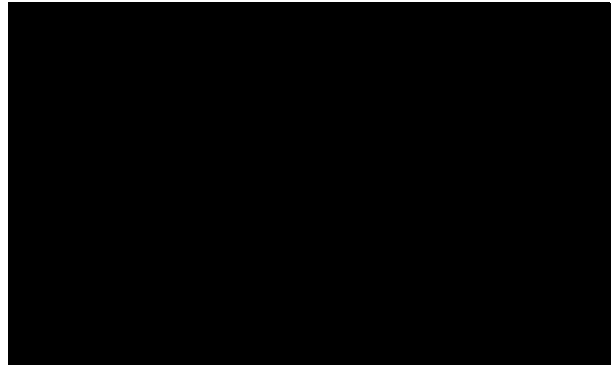

SA-003

---

## PREPARE FOR EMERGENCIES

- Be prepared if a fire starts or if an accident occurs.
  - It is recommended that a first aid kit and fire extinguisher be kept on hand.
  - Thoroughly read and understand the label attached on the fire extinguisher to use it properly.
  - To ensure that a fire extinguisher can be always used when necessary, check and service the fire extinguisher at the recommended intervals as specified in the fire-extinguisher manual.
- Establish emergency procedure guidelines to cope with fires and accidents.
- Keep emergency numbers for doctors, ambulance service, hospital, and fire department posted near your telephone.

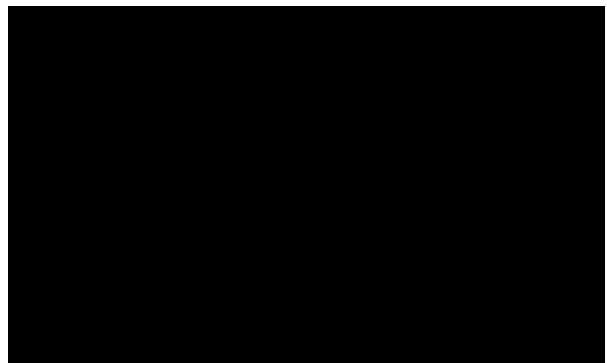

SA-437

# SAFETY

---

## WEAR PROTECTIVE CLOTHING

- Wear close fitting clothing and personal protective safety equipment (PPE) appropriate to the job.

You may need:

- A hard hat
- Safety shoes
- Safety glasses, goggles, or face shield
- Heavy gloves
- Hearing protection
- Reflective clothing
- Wet weather gear
- Respirator or filter mask.

Be sure to wear the correct equipment and clothing for the job. Do not take any chances.

- Avoid wearing loose clothing, jewelry, or other items that can catch on control levers or other parts of the rigid dump truck.
- Operating equipment safely requires the full attention of the operator. Do not wear radio or music headphones while operating the rigid dump truck.



SA-438

---

## PROTECT AGAINST NOISE

- Prolonged exposure to loud noise can cause impairment or loss of hearing.
- Wear a suitable hearing protective device such as ear muffs or ear plugs to protect against objectionable or uncomfortably loud noises. This may be necessary when working outside of the cab during the Pre-Operation Inspection, for example.

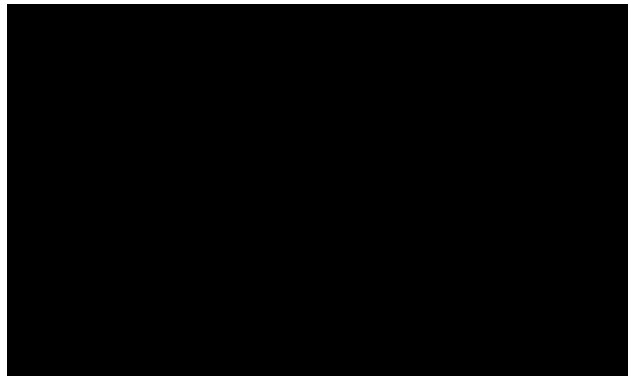

SA-434

---

## PROTECT AGAINST FLYING DEBRIS

- If flying debris hit eyes or any other part of the body, serious injury may result.
- Guard against injury from flying pieces of metal or debris; wear goggles or safety glasses.

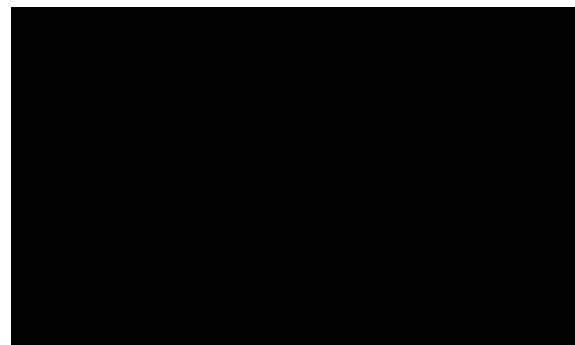

SA-432

## SAFETY

---

### GENERAL PRECAUTIONS FOR CAB

- Before entering the cab, thoroughly remove all dirt and/or oil from the soles of your work boots. If any controls such as a pedal are operated with dirt and/or oil on the soles of the operator's work boots the operator's foot may slip off the pedal, possibly resulting in a personal accident.
- Don't leave parts and/or tools lying around the operator's seat. Store them in their specified locations.
- Avoid storing transparent bottles in the cab. Don't attach any transparent type window decorations on the windowpanes as they may focus sunlight, possibly starting a fire.
- Refrain from listening to a radio or music with headphones or mobile telephones in the cab while operating the rigid dump truck.
- Keep all flammable objects and/or explosives away from the rigid dump truck.
- After using the ashtray, always cover it to extinguish the match and/or tobacco.
- Don't leave cigarette lighters in the cab. When the temperature in the cab increases, the lighter may explode.
- When operating the rigid dump truck, both doors should be closed at all times.

Thank you so much for reading.  
Please click the “Buy Now!”  
button below to download the  
complete manual.



After you pay.

You can download the most  
perfect and complete manual in  
the world immediately.

Our support email:

[ebooklibonline@outlook.com](mailto:ebooklibonline@outlook.com)