

Operator's Manual

EH5000ACII

Rigid Dump Truck

Serial No.
EH5000ACII
EH5000ACII

411RD: 77706 and Up
8RAAA: 8RAAAN00001000 and Up

HITACHI

INTRODUCTION

Read this manual carefully to learn how to operate and service your rigid dump truck correctly. Failure to do so could result in personal injury and/or rigid dump truck damage.

This manual should be considered a permanent part of your rigid dump truck and should remain with the rigid dump truck when you sell it.

Measurements in this manual are given in both metric and customary U.S. unit equivalent. Use only correct replacement parts and fasteners. Metric and inch fasteners may require a specific metric or inch wrench.

Write product identification numbers in the Rigid dump truck Numbers section. Accurately record all the numbers to help in tracing the rigid dump truck should it be stolen. Your dealer also needs these numbers when you order parts. File a copy of the identification numbers in a secure place off the rigid dump truck.

Warranty is provided as a part of Hitachi's support program for customers who operate and maintain their equipment as described in this manual. The warranty is explained on the warranty certificate which you should have received from your dealer.

This warranty provides you the assurance that Hitachi will back its products when defects occur within the warranty period. In some circumstances, Hitachi also provides field improvements, often without charge to the customer, even if the product is out of warranty. **Should the equipment be abused or modified to change its performance beyond the original factory specifications, the warranty will become void and field improvements may be denied.**

Setting fuel delivery above specifications or otherwise overpowering rigid dump trucks will result in such action.

Moreover, when replacement parts are required, be sure to use genuine Hitachi parts. Failure to do so may result in voiding the warranty and/or denial of field improvements.

Only qualified, experienced operators officially licensed (according to local law) should be allowed to operate the rigid dump truck.

Only officially, licensed personnel should be allowed to inspect/service the rigid dump truck.

The Yellow Pages in this operator's manual contain IMPORTANT SAFETY INFORMATION.

Read these pages thoroughly and familiarize yourself with the safety standards and recommendations set forth in these yellow pages of the manual.

Follow all safety instructions prior to and while operating the rigid dump truck.

Prior to operating this rigid dump truck, it may be necessary to make modifications to it so that it complies with the local standards (including safety standards) and requirements of your country. Please do not operate this rigid dump truck until such compliance has been confirmed. Please contact Hitachi Construction Truck Manufacturing Ltd. or any of our authorized dealers concerning compliance.

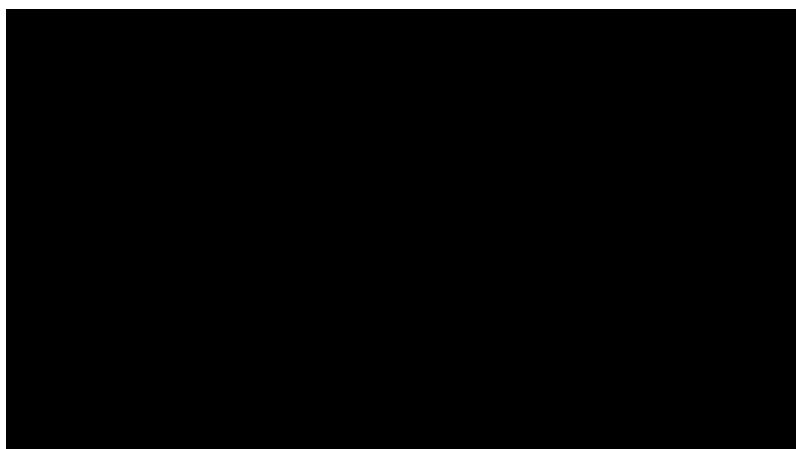

INTRODUCTION

(Blank)

INDEX

MACHINE NUMBERS

SAFETY

SAFETY SIGNS

COMPONENTS NAME

OPERATOR'S STATION

BREAK-IN

OPERATING THE RIGID DUMP TRUCK

OPERATING METHODS

TRANSPORTING

MAINTENANCE

STORAGE

TROUBLESHOOTING

SPECIFICATIONS

OPTIONS

INFORMATION FEEDBACK FORM

ALPHABETICAL INDEX

CONTENTS

INTRODUCTION

INDEX

MACHINE NUMBERS

RIGID DUMP TRUCK TYPE AND SERIAL NUMBER.....	M-1
ROLLOVER PROTECTIVE STRUCTURE NAMEPLATE	M-1
FRAME PRODUCT IDENTIFICATION NUMBER	M-2
MTU DETROIT DIESEL DATA TAG.....	M-2
LEFT WHEEL MOTOR DATA TAG	M-3
RIGHT WHEEL MOTOR DATA TAG.....	M-3
LEFT SPINDLE ASSEMBLY DATA TAG	M-3
RIGHT SPINDLE ASSEMBLY DATA TAG.....	M-3
TRACTION ALTERNATOR DATA TAG	M-4
TRACTION CONTROL CABINET DATA TAG	M-4

SAFETY

RECOGNIZE SAFETY INFORMATION	S-1
UNDERSTAND SIGNAL WORD	S-1
OPERATOR'S QUALIFICATIONS.....	S-2
DUTIES OF THE OPERATOR	S-2
INSPECT RIGID DUMP TRUCK	S-2
FOLLOW SAFETY INSTRUCTIONS.....	S-3
PREPARE FOR EMERGENCIES.....	S-3
WEAR PROTECTIVE CLOTHING.....	S-4
PROTECT AGAINST NOISE	S-4
PROTECT AGAINST FLYING DEBRIS.....	S-4
GENERAL PRECAUTIONS FOR CAB.....	S-5
USE HANDHOLDS AND STEPS.....	S-6
ADJUST THE OPERATOR'S SEAT	S-6
FASTEN YOUR SEAT BELT	S-7
HANDLE STARTING AIDS SAFELY	S-7
OPERATE ONLY FROM OPERATOR'S SEAT	S-8
JUMP STARTING	S-8
KEEP RIDERS OFF RIGID DUMP TRUCK... ..	S-8
PROTECT AGAINST FALLING STONES	S-9
PROVIDE SIGNALS FOR JOBS	S-9
OPERATE THE RIGID DUMP TRUCK SAFELY	S-10
AVOID INJURY FROM RUNNING OVER CRUSH AREA.....	S-11
AVOID TIPPING.....	S-12
AVOID INJURY FROM ROLLAWAY	S-13
NEVER TRAVEL WITH BODY OFF THE FRAME	S-13
OPERATING WITH THE RIGID DUMP TRUCK NEAR OVERHEAD WIRES.....	S-14
OPERATING WITH THE RIGID DUMP TRUCK NEAR HIGH VOLTAGE OVERHEAD POWER LINES.....	S-14
PARK RIGID DUMP TRUCK SAFELY	S-15
SAFE HANDLING OF OFF ROAD TIRES... ..	S-16

DISCHARGE ACCUMULATORS	S-16
HANDLE FLUIDS SAFELY AVOID FIRES.. ..	S-17
A FEW SIMPLE RULES WHEN SERVICING	S-18
USE TOOLS PROPERLY.....	S-20
PREVENT BURNS	S-21
REPLACE RUBBER HOSES PERIODICALLY	S-21
AVOID HIGH-PRESSURE FLUIDS.....	S-22
FIRE PREVENTION MEASURES	S-23
EVACUATING IN CASE OF FIRE.....	S-25
BEWARE OF EXHAUST FUMES.....	S-25
PRECAUTIONS FOR WELDING, CUTTING, AND GRINDING	S-26
REMOVE PAINT BEFORE WELDING OR CUTTING.....	S-26
AVOID HEATING NEAR PRESSURIZED FLUID LINES	S-27
AVOID APPLYING HEAT TO LINES CONTAINING FLAMMABLE FLUIDS.....	S-27
PREVENT BATTERY EXPLOSIONS	S-28
SERVICE AIR CONDITIONING SYSTEM SAFELY	S-38
HANDLE CHEMICAL PRODUCTS SAFELY.....	S-29
DISPOSE OF WASTE PROPERLY	S-29

SAFETY SIGNS

FRONT VISIBILITY.....	SS-5
SAFETY RADIATOR	SS-5
NO JUMP START	SS-5
FAN BLADE	SS-5
HIGH VOLTAGE	SS-6
TIRE SIZE	SS-6
GROSS MACHINE WEIGHT	SS-6
RETARDER DECAL	SS-6
FORWARD & REVERSE PROPULSION INHIBIT	SS-7
READ & UNDERSTAND OPERATOR'S MANUAL	SS-7
HIGH PRESSURE	SS-7
BODY DOWN	SS-7
REAR VISIBILITY	SS-8
BODY LOCK POSITION.....	SS-8
FOUR POINT LIFT	SS-8
NO TOWING	SS-8
OVERHEAD LOAD	SS-9
CRUSH AREA	SS-9
BATTERY DISCONNECT	SS-9
EMERGENCY SHUTDOWN	SS-9
PLANETARY LUBRICANT LEVEL.....	SS-10
MAINTENANCE FREE BATTERY	SS-10
LOCK BODY	SS-10
CONTENTS UNDER PRESSURE	SS-10
DO NOT LIFT.....	SS-11
FASTEN THE SEAT BELT	SS-11
AVOID EXHAUST FUMES	SS-11
PEDAL LOCATION.....	SS-11
DISCHARGE ACCUMULATORS	SS-12

CONTENTS

COMPONENTS NAME

COMPONENTS NAME1-1

OPERATOR'S STATION

DASH CONTROLS2-1
LAMP DISPLAY2-17
LCD MONITOR2-27
CONTROL, AC & HEATER2-39
STEERING COLUMN CONTROLS2-43
FOOT CONTROLS2-46
CENTER CONSOLE CONTROLS2-47
OPERATOR'S SEAT ADJUSTMENT2-51
SEAT CONTROLS2-52
CAB REAR, COMPONENT LAYOUT2-55
CAB OUTSIDE REAR PANEL2-56
REMOTE MOUNTED CONTROLS2-57
HITACHI RIGID DUMP TRUCK
PAYLOAD POLICY2-60
HAUL CYCLE DATA2-62

BREAK-IN

OBSERVE RIGID DUMP TRUCK
CLOSELY3-1

OPERATING THE RIGID DUMP TRUCK

INSPECT RIGID DUMP TRUCK
DAILY BEFORE STARTING4-1
PRE-OPERATION INSPECTION4-2
OIL AND WATER LEAKS4-4
CHECK INSTRUMENTS & CONTROLS
BEFORE STARTING4-5
COOLANT LEVEL CHECK4-5
STARTING ENGINE4-6
USING BOOSTER BATTERIES4-9
SUPPLEMENTAL STEER/BRAKE
OPERATIONAL TEST4-11
LOADING4-12
LOAD WEIGHING4-13
HAULING4-17
DUMPING4-18
STOPPING4-21
ANTI-ROLL PROTECTION4-21
STOPPING THE ENGINE4-22

OPERATING METHODS

GENERAL INFORMATION5-1
COOLING A HOT ENGINE5-2
SHIFTING DIRECTIONAL RANGE
SELECTOR5-2
ACCELERATOR PEDAL5-3
STEERING5-3
CRUISE CONTROL5-4
DYNAMIC RETARDER5-4
RETARDER DECAL5-5
SERVICE BRAKES5-7
PARK BRAKE5-7

LOAD DUMP BRAKE SWITCH5-8
OPERATING THE HOIST CONTROL
LEVER5-9
RIGID DUMP TRUCK STUCK IN DEEP
SAND, SNOW OR MUD5-13
COLD WEATHER RESTRICTIONS5-13
TOWING5-14
PARKING RIGID DUMP TRUCK5-16

TRANSPORTING THE RIGID DUMP TRUCK

TRANSPORTING6-1

MAINTENANCE

CORRECT MAINTENANCE AND
INSPECTION PROCEDURES7-1
WASHING RIGID DUMP TRUCK7-1
SERVICE RIGID DUMP TRUCK AT
SPECIFIED INTERVALS7-2
RECOMMENDED LUBRICANTS7-3
RECOMMENDED FUEL7-8
PREPARE RIGID DUMP TRUCK FOR
SERVICE7-9
INSTALLING BODY PROP PINS7-10
REMOVAL AND STORAGE OF
BODY PROP PINS7-11
ELECTRICAL DISCONNECTS BEFORE
WELDING ON THE RIGID DUMP
TRUCK7-12
MAINTENANCE INTERVAL GUIDE7-13
A. GREASING7-22
B. ENGINE7-26
C. POWER TRANSMISSION7-31
D. HYDRAULIC STEERING/BRAKE
APPLY SYSTEM7-34
E. HYDRAULIC HOIST/BRAKE
COOLING SYSTEM7-40
F. BRAKES, SERVICE AND PARK7-45
G. FUEL SYSTEM7-48
H. AIR CLEANER7-51
I. COOLING SYSTEM7-56
J. ELECTRICAL SYSTEM7-63
K. SUSPENSION, WHEELS AND TIRES7-78
L. CAB7-83
M. GENERAL7-89
MAINTENANCE OF OPTIONAL
SYSTEMS7-93

STORAGE

SHORT TERM STORAGE8-1
MODERATE TERM STORAGE8-3
LONG TERM STORAGE8-5
RETURN TO SERVICE8-6

CONTENTS

TROUBLESHOOTING

ENGINE	9-1
ENGINE COOLING.....	9-4
STARTER AND MOUNTING	9-4
AIR CLEANER	9-5
ELECTRICAL SYSTEM	9-6
HYDRAULIC SYSTEM.....	9-9
HYDRAULIC HOIST SYSTEM	9-11
HYDRAULIC STEER SYSTEM	9-12
STEER PUMP	9-13
STEER CONTROL VALVE	9-14
FRONT AXLE.....	9-16
REAR AXLE	9-17
HOIST PUMP DRIVELINE.....	9-18
REAR AXLE PLANETARY	9-18
PARK BRAKE	9-19

SPECIFICATIONS

SERVICE SPECIFICATIONS	
EH5000ACII	10-1
MACHINE DIMENSIONS.....	10-8
PERFORMANCE/RETARDER CHARTS ...	10-12

OPTIONS

OPTIONS	11-1
---------------	------

INFORMATION FEEDBACK FORM

INFORMATION FEEDBACK FORM.....	12-1
--------------------------------	------

INDEX

ALPHABETICAL INDEX	13-1
--------------------------	------

MACHINE NUMBERS

The numbers asked for in this section are the individual numbers; model, product identification, serial, type and manufacturer given to each machine and major components. These numbers are requested when inquiring about replacement parts or machine service. Fill in the blank spaces in this section to immediately have them available upon request.

MACHINE TYPE AND SERIAL NUMBER

PRODUCT
MODEL
NUMBER: _____

PRODUCT
IDENTIFICATION
NUMBER: _____

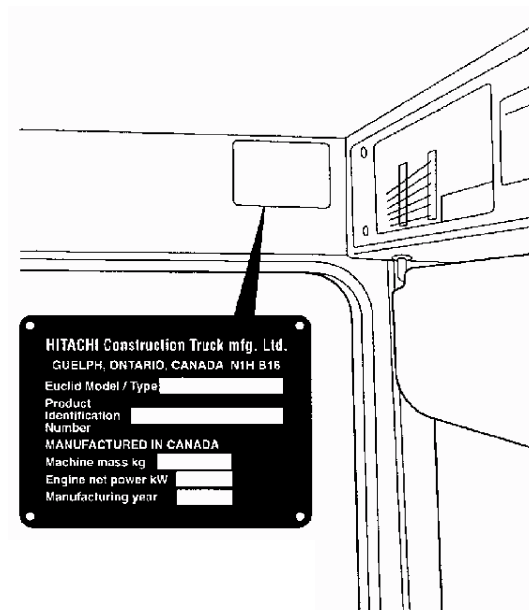

EL20456

ROLLOVER PROTECTIVE STRUCTURE NAMEPLATE

HITACHI
MODEL
TYPE: _____

ROPS
MODEL
NUMBER: _____

MAX
MACHINE
MASS, M-kg: _____

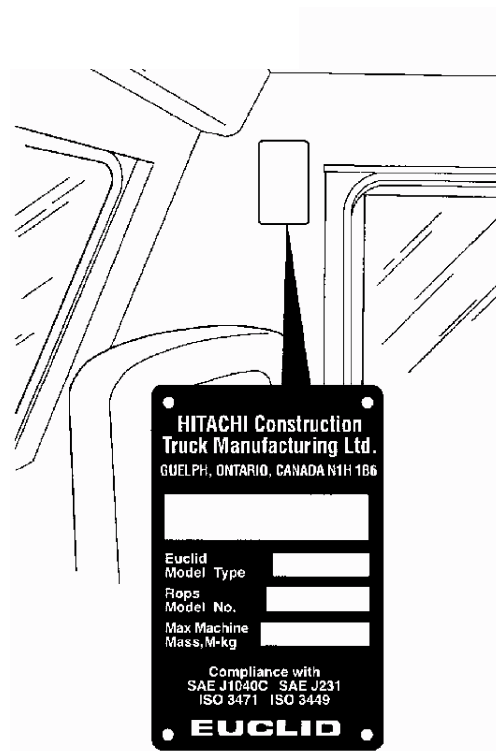

EL20475

MACHINE NUMBERS

FRAME PRODUCT IDENTIFICATION NUMBER

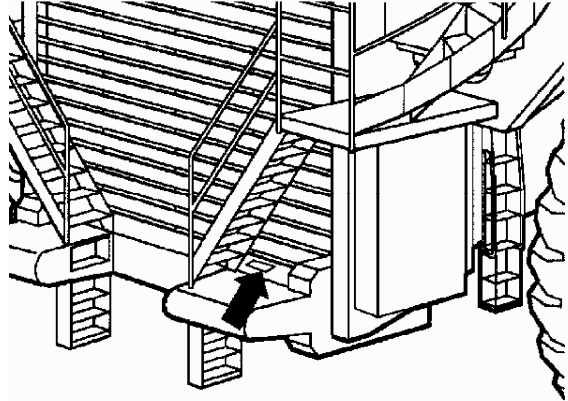

EL20210

MTU DETROIT DIESEL DATA TAG

TYPE: _____

MFG. NO.: _____

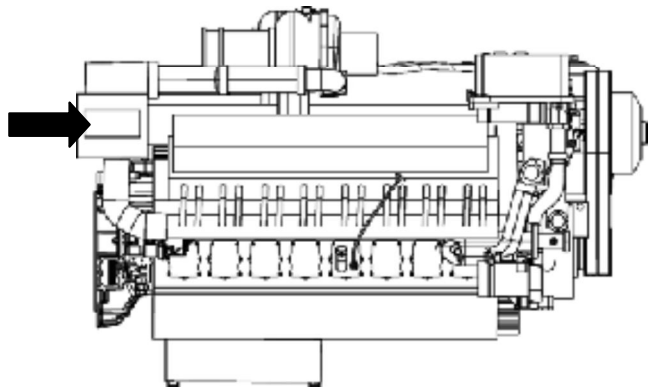

MACHINE NUMBERS

LEFT WHEEL MOTOR DATA TAG

TYPE: _____

MFG. NO.: _____

RIGHT WHEEL MOTOR DATA TAG

TYPE: _____

MFG. NO.: _____

LEFT SPINDLE ASSEMBLY DATA TAG

TYPE: _____

MFG. NO.: _____

RIGHT SPINDLE ASSEMBLY DATA TAG

TYPE: _____

MFG. NO.: _____

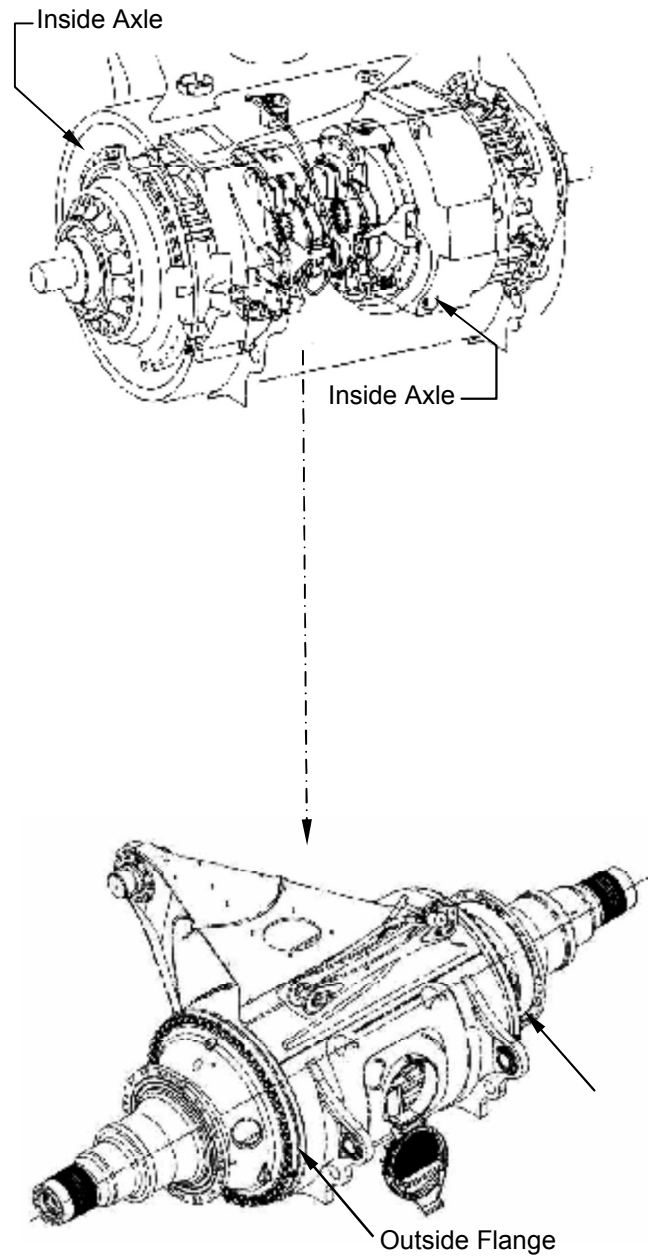

MACHINE NUMBERS

TRACTION ALTERNATOR DATA TAG

TYPE: _____

MFG. NO.: _____

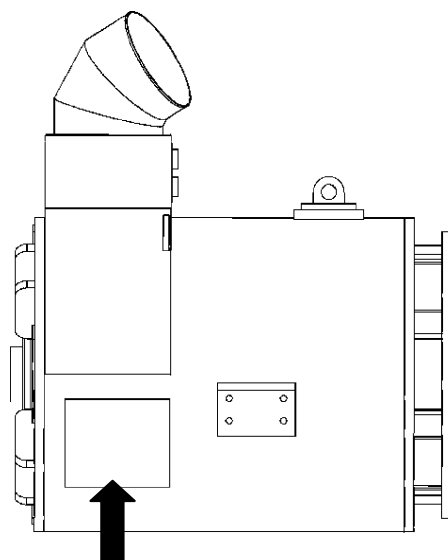

TRACTION CONTROL CABINET DATA TAG

TYPE: _____

MFG. NO.: _____

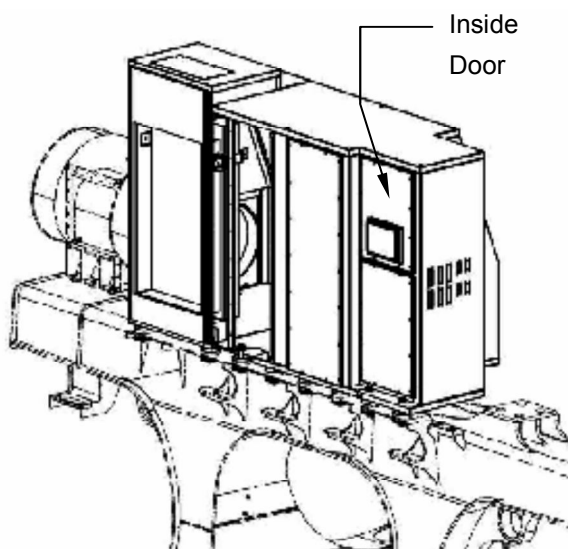

SAFETY

RECOGNIZE SAFETY INFORMATION

• SAFETY ALERT SYMBOL

- This symbol, which will appear at various points in the manual and on the rigid dump truck together with a warning statement, means: **“Warning, be alert! Your safety is involved!” Carefully read the message that follows. It is the obligation of the operator to make sure that all warning decals are in place on the rigid dump truck and that they are readable. Accidents may otherwise occur.**
- Follow recommended precautions and safe operating practices.
- Every country (Jurisdiction) has its own safety regulations. It is the obligation of the operator to know and follow these. This also applies to local regulations covering different types of work. Should the recommendations in this manual deviate from those of your country (Jurisdiction), your local safety regulations should be followed.

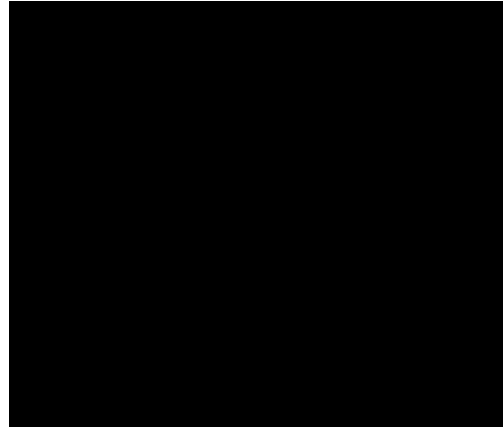

UNDERSTAND SIGNAL WORD

- On the rigid dump truck safety signs, signal words designating the degree or level of hazard – DANGER, WARNING, or CAUTION – are used with the safety alert symbol.
 - **DANGER** indicates an imminently hazardous situation which, if not avoided, will result in death or serious injury.
 - **WARNING** indicates a potential hazardous situation which, if not avoided, could result in death or serious injury.
 - **CAUTION** indicates a potentially hazardous situation which, if not avoided, may result in minor or moderate injury.
 - **DANGER or WARNING safety signs** are located near specific hazards. General precautions are listed on **CAUTION safety signs**.
- These signal words also call attention to safety messages in this manual.
- To avoid confusing rigid dump truck protection with personal safety messages, a signal word **IMPORTANT** indicates a situation which, if not avoided, could result in damage to the rigid dump truck.

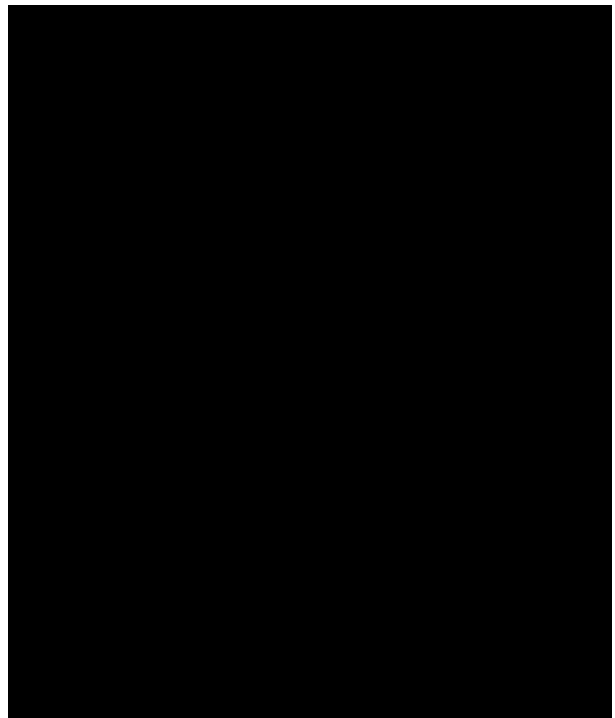

■ *NOTE: indicates an additional explanation for an element of information.*

SAFETY

OPERATOR'S QUALIFICATIONS

- Only trained personnel should operate the rigid dump truck.
- Operator should be of legal rigid dump truck operating age according to country (Jurisdiction) regulations and familiar with the operation and maintenance of the rigid dump truck.
- Operator must be licensed if required by National Rules and Regulations.

DUTIES OF THE OPERATOR

- Before you operating the rigid dump truck, this manual must be read and understood. Contact your supervisor if you do not understand any portion of this manual. By reading and understanding the manual, you will become aware of and observe how to avoid injury and damage.
- Know the work area and the company rules and regulations
- Never operate the rigid dump truck while under the influence of alcohol, medicine or other drugs.

Due to the position of the cab and size of the rigid hauler, the operator has limited visibility to areas close to or near the rigid dump truck. No person should enter the operating area of the rigid dump truck when it is in operation without first notifying the operator. If a person has to enter the operating area of the rigid dump truck, they should signal the operator and wait for an acknowledgement of recognition by the operator.

During rigid dump truck operation no one should be allowed to get any closer than 7m (23 ft.) of the rigid dump truck. Any closer will limit one's time to react and move away from the vehicle when it starts.

INSPECT RIGID DUMP TRUCK

- Inspect your rigid dump truck carefully each day or shift by walking around it before you start it to avoid personal injury.
- Be sure to cover all points described under "Pre-Operation Inspection" found in the OPERATING THE RIGID DUMP TRUCK section in this operator's manual.



SA-435

SAFETY

FOLLOW SAFETY INSTRUCTIONS

- Carefully read and follow all safety signs on the rigid dump truck and all safety messages in this manual.
- Safety signs should be installed, maintained and replaced when necessary.
 - If a safety sign or this manual is damaged or missing, order a replacement from your authorized Hitachi dealer in the same way you order other replacement parts (be sure to state rigid dump truck model and serial number when ordering).
- Learn how to operate the rigid dump truck and its controls correctly and safely.
- Allow only trained qualified, authorized personnel to operate the rigid dump truck.
- Keep your rigid dump truck in proper working condition.
 - Unauthorized modifications of the rigid dump truck may impair its function and/or safety and affect rigid dump truck life.
- The safety messages in this SAFETY chapter are intended to illustrate basic safety procedures of rigid dump trucks. However it is impossible for these safety messages to cover every hazardous situation you may encounter. If you have any questions, you should first consult your supervisor and/or your authorized Hitachi dealer before operating or performing maintenance work on the rigid dump truck.

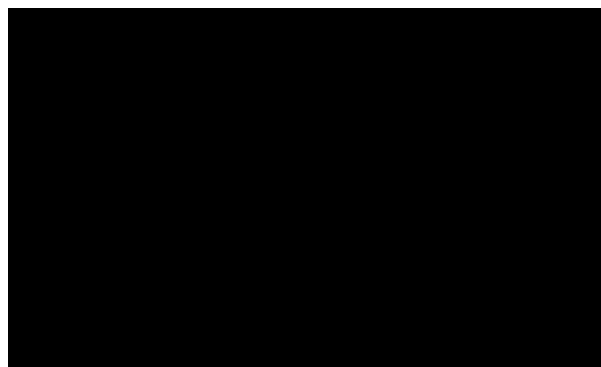

SA-003

PREPARE FOR EMERGENCIES

- Be prepared if a fire starts or if an accident occurs.
 - It is recommended that a first aid kit and fire extinguisher be kept on hand.
 - Thoroughly read and understand the label attached on the fire extinguisher to use it properly.
 - To ensure that a fire extinguisher can be always used when necessary, check and service the fire extinguisher at the recommended intervals as specified in the fire-extinguisher manual.
- Establish emergency procedure guidelines to cope with fires and accidents.
- Keep emergency numbers for doctors, ambulance service, hospital, and fire department posted near your telephone.

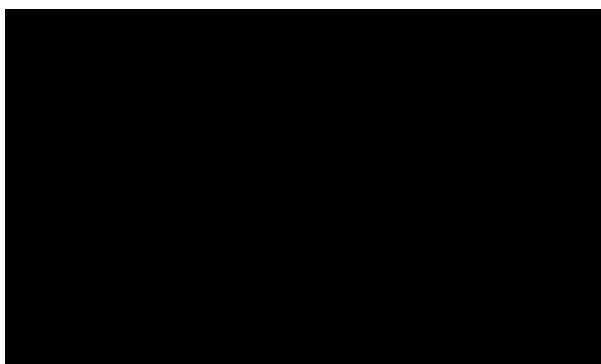

SA-437

SAFETY

WEAR PROTECTIVE CLOTHING

- Wear close fitting clothing and personal protective safety equipment (PPE) appropriate to the job.

You may need:

- A hard hat
- Safety shoes
- Safety glasses, goggles, or face shield
- Heavy gloves
- Hearing protection
- Reflective clothing
- Wet weather gear
- Respirator or filter mask.

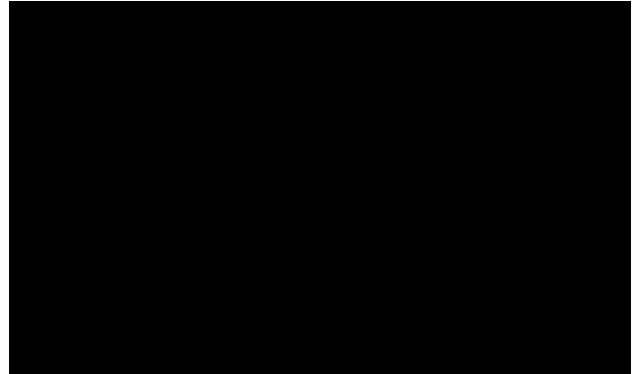

SA-438

Be sure to wear the correct equipment and clothing for the job. Do not take any chances.

- Avoid wearing loose clothing, jewelry, or other items that can catch on control levers or other parts of the rigid dump truck.
- Operating equipment safely requires the full attention of the operator. Do not wear radio or music headphones while operating the rigid dump truck.

PROTECT AGAINST NOISE

- Prolonged exposure to loud noise can cause impairment or loss of hearing.
- Wear a suitable hearing protective device such as ear muffs or ear plugs to protect against objectionable or uncomfortably loud noises. This may be necessary when working outside of the cab during the Pre-Operation Inspection, for example.

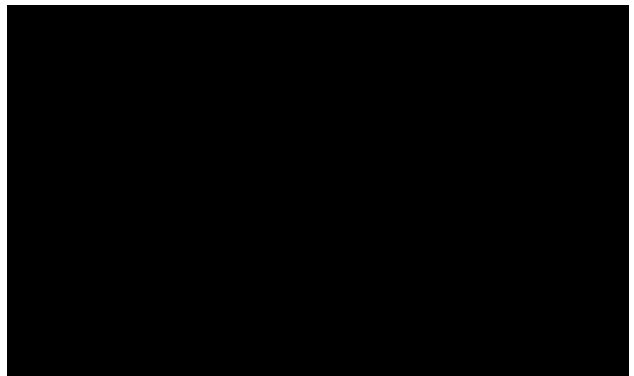

SA-434

PROTECT AGAINST FLYING DEBRIS

- If flying debris hit eyes or any other part of the body, serious injury may result.
- Guard against injury from flying pieces of metal or debris; wear goggles or safety glasses.

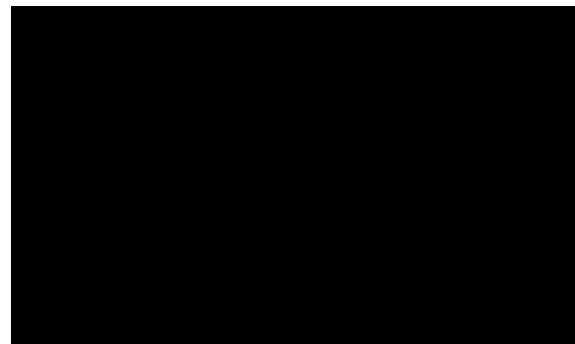

SA-432

Thank you so much for reading.
Please click the “Buy Now!”
button below to download the
complete manual.



After you pay.

You can download the most
perfect and complete manual in
the world immediately.

Our support email:

ebooklibonline@outlook.com