

PART NO. EM18K-1-4

HITACHI

Operator's Manual

EX 1900-6

Hydraulic Excavator

Serial No 001001 and up

INDEX

MACHINE NUMBERS

SAFETY

SAFETY SIGNS

COMPONENTS NAME

HANDLING LADDER/EMERGENCY ESCAPE DEVICE

OPERATOR'S STATION

BREAK-IN

OPERATING ENGINE

DRIVING MACHINE

OPERATING MACHINE

MAINTENANCE

MAINTENANCE UNDER SPECIAL ENVIRONMENTAL CONDITIONS

STORAGE

TROUBLESHOOTING

SPECIFICATIONS

INDEX

CONTENTS

MACHINE NUMBERS	1	Remove Paint Before Welding or Heating	S-28
SAFETY	S-1	Beware of Asbestos and Silicon Dust and Other Contamination	S-29
Recognize Safety Information	S-1	Prevent Battery Explosions	S-30
Understand Signal Words.....	S-1	Service Air Conditioning System Safely	S-30
Follow Safety Instructions.....	S-2	Handle Chemical Products Safely.....	S-31
Prepare for Emergencies.....	S-3	Dispose of Waste Properly.....	S-31
Wear Protective Clothing.....	S-3	Precautions for Communication Terminal.....	S-31
Protect Against Noise	S-3	SAFETY SIGNS	S-32
Inspect Machine	S-4	COMPONENTS NAME	1-1
General Precautions for CAB	S-4	Components Name	1-1
Use Handholds and Steps	S-5	HANDLING LADDER/EMERGENCY ESCAPE DEVICE	1-2
Adjust Operator's Seat.....	S-5	Using Ladder	1-2
Ensure Safety Before Rising from or Leaving Operator's Seat	S-5	Operating Ladder on the Ground.....	1-3
Fasten Your Seat Belt.....	S-6	Extending	1-3
Move and Operate Machine Safely.....	S-6	Retracting	1-3
Handle Starting Aids Safely	S-6	Operating Ladder on the Upper-Structure	1-3
Operate Only from Operator's Seat	S-7	Extending	1-3
Jump Starting	S-7	Retracting	1-3
Precautions for Operations	S-8	Emergency Escape Device	1-4
Investigate Job Site Beforehand	S-9	Emergency Exit	1-5
Provide Signals for Jobs Involving Multiple Machines....	S-10	Evacuating in Case of Fire.....	1-5
Confirm Direction of Machine to be Driven	S-10	OPERATOR'S STATION	1-7
Drive Machine Safely.....	S-11	Cab Features.....	1-7
Avoid Injury from Rollaway Accidents.....	S-13	Monitor Display.....	1-8
Avoid Injury from Back-Over and Swing Accidents	S-14	Starting Check Screen	1-8
Keep Person Clear from Working Area.....	S-15	Meter Check Screen.....	1-9
Never Position Bucket Over Anyone	S-15	Tachometer.....	1-10
Avoid Undercutting.....	S-15	Coolant Temperature Gauge.....	1-10
Avoid Tipping.....	S-16	Hydraulic Oil Temperature Gauge.....	1-10
Never Undercut a High Bank.....	S-16	Fuel Gauge.....	1-10
Dig with Caution.....	S-17	Engine Oil Pressure Gauge.....	1-11
Operate with Caution	S-17	Engine Oil Temperature Gauge	1-11
Avoid Power Lines.....	S-17	Hour Meter.....	1-11
Precautions for Lightning.....	S-18	Warning Indicators.....	1-11
Object Handling	S-18	Alternator Indicator	1-11
Protect Against Flying Debris	S-18	Pump Transmission Oil Level Indicator.....	1-12
Park Machine Safely.....	S-19	Engine Stop Indicator	1-12
Handle Fluids Safely – Avoid Fires.....	S-19	Engine Oil Pressure Indicator	1-12
Practice Safe Maintenance.....	S-20	Coolant Overheat Indicator	1-12
Warn Others of Service Work	S-21	Coolant Level Indicator	1-13
Support Machine Properly.....	S-21	Engine Over Run Indicator	1-13
Stay Clear of Moving Parts	S-22	Fuel Temperature Indicator.....	1-13
Prevent Parts from Flying	S-22	Hydraulic Oil Level Indicator	1-13
Store Attachments Safely	S-23	Stop Valve Indicator.....	1-14
Prevent Burns.....	S-23	Auto-Lubrication Indicator	1-14
Replace Rubber Hoses Periodically.....	S-23	Fast-Filling Indicator	1-15
Avoid High-Pressure Fluids	S-24	Emergency Engine Stop Indicator	1-15
Prevent Fires.....	S-25	Tension Indicator	1-15
Evacuating in Case of Fire.....	S-26	Electric Lever Indicator.....	1-15
Beware of Exhaust Fumes.....	S-27	Caution Indicators.....	1-16
Precautions for Welding and Grinding	S-27	Exhaust Temperature Indicator	1-16
Avoid Heating Near Pressurized Fluid Lines	S-27	Engine Warning Indicator.....	1-16
Avoid Applying Heat to Lines Containing Flammable Fluids	S-27	Hydraulic Oil Overheat Indicator	1-16
Precautions for Handling Accumulator	S-28		

CONTENTS

Pump Contamination Indicator	1-16	Absorber Adjusting	1-44
Ladder Position Indicator	1-17	Backrest Adjustment	1-45
Air Cleaner Restriction Indicator	1-17	Lumbar Support Adjustment	1-45
Electrical Equipment Box Indicator.....	1-17	Headrest Adjustment	1-45
Status Indicators	1-17	Seat Belt	1-46
Auto-Idle Indicator.....	1-17	Seat Belt.....	1-46
Travel Mode Indicator	1-18	Cab Door Release Button	1-47
Prelub Indicator.....	1-18	Opening Cab Left Window.....	1-47
Left Console.....	1-19	BREAK-IN	2-1
Warning Lamp	1-19	Observe Machine Closely.....	2-1
Caution Lamp	1-19	Every 10 Hours or Each Shift	2-1
Key Pad.....	1-19	After the First 50 Hours	2-2
Monitor Contrast Switch.....	1-19	OPERATING ENGINE	3-1
Wiper Switch	1-20	Inspect Machine Daily Before Starting	3-1
Washer Switch	1-20	Before Turning Power ON.....	3-2
Wiper Delay Selector Switch	1-20	Turning Power ON.....	3-3
Air Conditioners	1-21	Starting Engine	3-8
Designations and Functions of Controls.....	1-22	Check Instruments After Starting.....	3-10
Cooling.....	1-24	Using Booster Batteries	3-11
Heating.....	1-24	Stopping Engine	3-13
Dehumidifying and Heating.....	1-24	Emergency Engine Stop Switch	3-14
Defrosting	1-25	Engine Stop Switches	3-15
Blower Operation Without Cooling or Heating.....	1-25	DRIVING MACHINE	4-1
Ventilation Cab.....	1-25	Drive Machine Carefully.....	4-1
AM/FM Radio Operation	1-26	Steering Machine Using Pedals.....	4-2
Controls on the Radio.....	1-26	Steering Machine Using Levers.....	4-3
Tuning Procedure	1-26	Travel Mode Switch	4-4
Station Presetting Procedure.....	1-27	Travel Alarm.....	4-5
Sound Adjustment	1-27	Operating on Soft Ground	4-6
Digital Clock Setting Procedure	1-28	Raise One Track Using Boom and Arm	4-6
Right Console.....	1-29	Towing Machine a Short Distance.....	4-7
Key Switch.....	1-29	Operating in Ground Condition.....	4-8
Emergency Engine Stop Switch	1-30	Parking Machine on Slopes	4-9
Engine Start Switch.....	1-30	Parking Machine	4-9
Engine Stop Switch.....	1-30	OPERATING MACHINE	5-1
Engine Speed Control Dial	1-31	Control Lever (ISO Pattern Backhoe).....	5-1
Work Light Switch	1-32	Control Lever (HITACHI Pattern Backhoe).....	5-2
Dome Light Switch	1-33	Control Lever (ISO Pattern Loading Shovel)	5-3
Maintenance Light Switch	1-34	Control Lever (HITACHI Pattern Loading Shovel).....	5-4
Entrance Light Switch	1-35	Bucket Open-Close Pedals (Loading Shovel)	5-5
Travel Mode Switch	1-36	Pilot Control Shut-Off Lever	5-6
Auto-Idle Switch	1-36	Engine Speed Control.....	5-7
Buzzer Stop Switch	1-37	Auto-Idle.....	5-8
Fast-Filling System	1-38	Warming-Up Operation	5-9
Rear Console	1-39	Warming-Up Cylinders and Motors	5-10
Horn Switch	1-40	Operate Machine Safely.....	5-11
Installation and Adjustment of Mirror and Cameras		Operating Backhoe.....	5-12
(Optional).....	1-41	Grading Operation.....	5-12
Camera Monitor (Optional).....	1-42	Avoid Abusive Operation	5-13
Adjusting Seat	1-43	Operating Tips	5-14
Seat Inclination Adjustment	1-43	Avoid Swinging Bucket to Move Objects	5-14
Seat Fore-Aft Adjustment	1-43	Loading Shovel Operation	5-15
Armrest Height Adjustment.....	1-43	Prohibited Operation.....	5-15
Seat/Backrest Fore-Aft Adjustment	1-44	Object Handling --- If Equipped.....	5-18
Seat Height Adjustment	1-44		
Seat/Armrest/Backrest Fore-Aft Adjustment.....	1-44		

CONTENTS

Overnight Storage Instructions.....	5-19	Replace Coolant Filter	7-90
MAINTENANCE	7-1	Change Coolant.....	7-91
Correct Maintenance and Inspection Procedures	7-1	Clean Radiator, After Cooler Interior	7-91
Check Hour Meter Regularly	7-2	Clean Radiator, After Cooler Core	7-92
Use Correct Fuels and Lubricants	7-2	Check Fan Belt for Wear	7-92
Prepare Machine for Maintenance.....	7-3	Check Radiator Stay for Looseness	7-92
Open Access Doors for Service.....	7-5	H. Air Conditioner.....	7-93
Inspection/Maintenance Lights	7-6	Recirculation Air Filter	7-93
Use a Chain to Prevent Falling Accidents	7-7	Ventilation Air Filter	7-94
Construction Outline	7-8	Check Refrigerant Quantity.....	7-95
Hydraulic System.....	7-10	Check Compressor Belt Tension	7-96
Periodic Replacement of Parts.....	7-13	Clean Condenser Core	7-97
Periodic Replacement of Rubber Hoses.....	7-14	Check Tightening Torque.....	7-98
Maintenance Interval Guide.....	7-18	Seasonal Maintenance.....	7-99
A. Greasing.....	7-22	I. Electrical System.....	7-100
Loading Shovel Front Joint Pins	7-23	Batteries	7-101
Backhoe Front Joint Pins	7-26	Replacing Fuses	7-106
Swing Bearing	7-29	Check Power Source Terminal.....	7-109
Swing Internal Gear.....	7-30	Check High Current Fuse.....	7-110
Center Joint.....	7-31	Check Electrical Cables and Wire Harnesses for	
Operating Lubricator	7-32	Short Circuits.....	7-111
B. Engine	7-34	Check Emergency Engine Stop Switch	7-113
Check Engine Oil Level.....	7-35	J. Miscellaneous	7-114
Change Engine Oil.....	7-36	Check Bucket Teeth.....	7-115
Replace Engine Oil Filters.....	7-36	Inspect Emergency Escape Device and Hanger	7-121
C. Transmission.....	7-38	Auto-Lubrication System	7-122
Pump Transmission	7-39	Check and Replace Seat Belt.....	7-126
Swing Reduction Gear	7-43	Check Windshield Washer Fluid Level	7-126
Travel Reduction Gear	7-45	Clean Air Horn Compressor Filter.....	7-127
D. Hydraulic System.....	7-47	Check and Adjust Track Sag	7-128
Inspection and Maintenance of Hydraulic Equipment... 7-48		Check Accumulator and Track Adjuster Cylinder	
Check Hydraulic Oil Level	7-50	Circuit.....	7-130
Drain Hydraulic Oil Tank Sump	7-51	Clean Side Frame Area	7-130
Replace Full-Flow Filter and Drain Filter Element	7-52	Check Tightening Torque of Bolts and Nuts.....	7-131
Replace Bypass Filter Element.....	7-54	MAINTENANCE UNDER SPECIAL ENVIRONMENTAL	
Replace Pilot Oil Filter Element.....	7-56	CONDITIONS	9-1
Change Hydraulic Oil.....	7-58	Maintenance Under Special Environmental Conditions... 9-1	
Replace Suction Filter.....	7-58	STORAGE	10-1
Replace High-Pressure Filter Element	7-61	Storing Machine.....	10-1
Replace Tank Air Breather Element	7-62	Removing Machine from Storage	10-2
Clean Oil Cooler Core	7-63	TRANSPORTING MACHINE	10-2
Check Hoses and Lines	7-64	TROUBLESHOOTING	11-1
E. Fuel System	7-70	Cummins Fault Code Lamps and Diagnostic	
Drain Fuel Tank Sump.....	7-72	Switches	11-1
Drain Fuel Filter Sediment	7-72	SPECIFICATIONS	12-1
Replace Fuel Filter Element	7-73	Specifications.....	12-1
Replace Fuel Filter.....	7-74	Working Range.....	12-2
Check Fuel Hoses	7-75	Working Range	12-3
Clean Fuel Cooler Core.....	7-77	INDEX	14-1
Clean Fuel Tank Breather.....	7-77		
F. Air Cleaner.....	7-78		
Clean Air Cleaner Outer Element	7-78		
Replace Air Cleaner Outer and Inner Elements.....	7-78		
G. Cooling System	7-80		
Check Coolant Level	7-81		
Check DCA4 Concentration in Coolant	7-82		

MACHINE NUMBERS

The manufacturing Nos. explained in this group is the individual number (serial No.) given to each machine and main components. These numbers are requested when inquiring any information on the machine and/or components. Fill these serial Nos. in the blank spaces in this group to immediately make them available upon request.

Machine Type and Serial Number

TYPE: _____

PRODUCT
IDENTIFICATION
NUMBER: _____

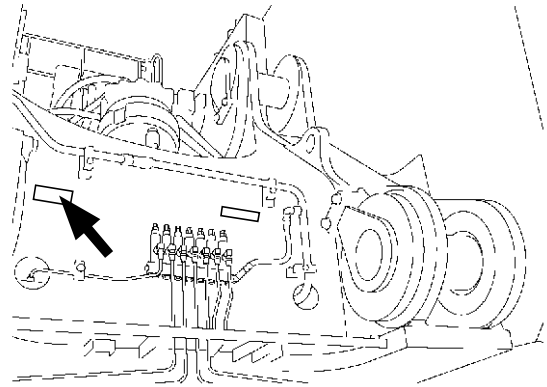

M18K-07-009

Product Identification Number

PRODUCT
IDENTIFICATION
NUMBER: _____

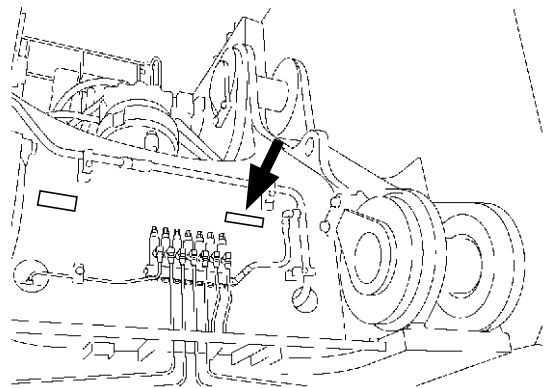
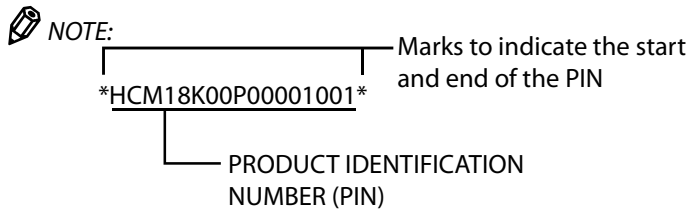

M18K-07-009

Engine Type and Serial Number

TYPE: _____

MFG. NO.: _____

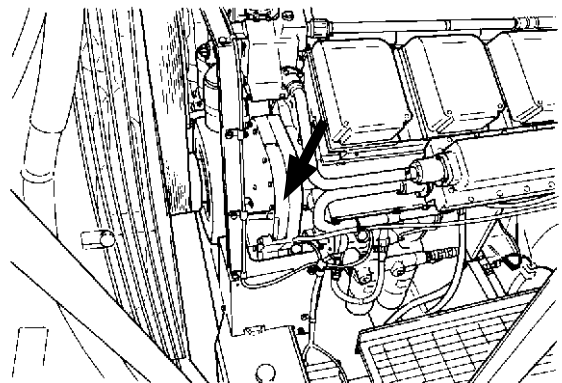

M117-07-092

Travel Motor Type and Serial Number

TYPE: _____

MFG. NO.: (LEFT) _____

MFG. NO.: (RIGHT) _____

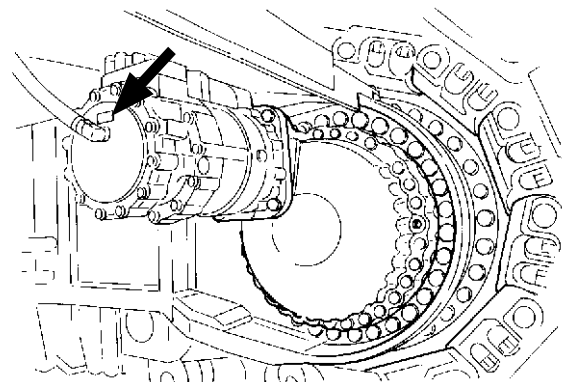

M144-12-002

MACHINE NUMBERS

Swing Motor Type and Serial Number

TYPE: _____
MFG. NO.: (FRONT) _____
MFG. NO.: (REAR) _____

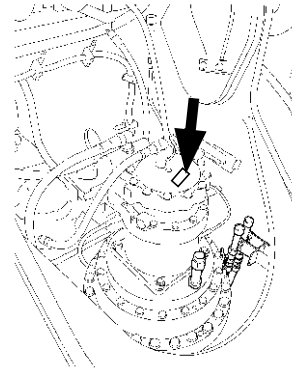

M18K-07-014

Hydraulic Pump Type and Serial Number

TYPE: _____
MFG. NO.: (1, 2) _____
MFG. NO.: (3, 4) _____
MFG. NO.: (5, 6) _____

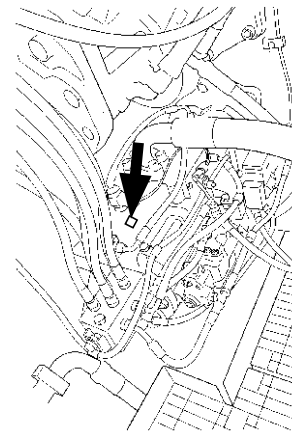

M18C-01-004

Front Type and Serial Number (Loading Shovel)

TYPE: _____
MFG. NO.: _____

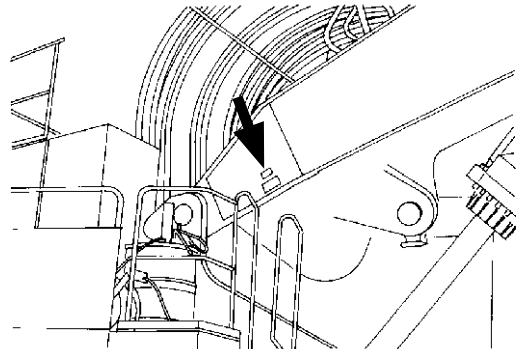

M117-12-001

Bucket Type and Serial Number (Loading Shovel)

TYPE: _____
MFG. NO.: _____

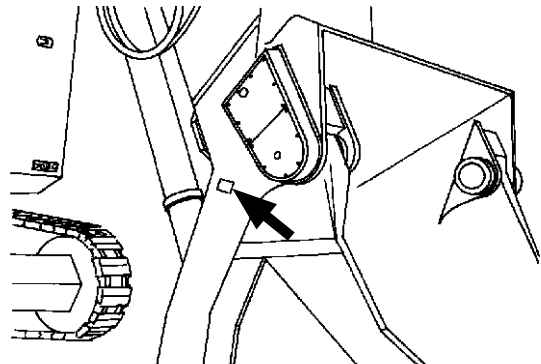

M117-12-003

MACHINE NUMBERS

Front Type and Serial Number (Backhoe Boom)

TYPE: _____

MFG. NO.: _____

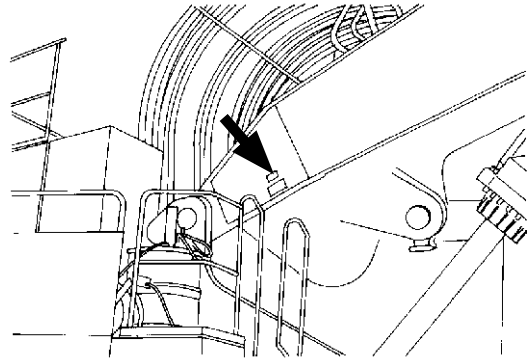

M117-12-001

Front Type and Serial Number (Backhoe Arm)

TYPE: _____

MFG. NO.: _____

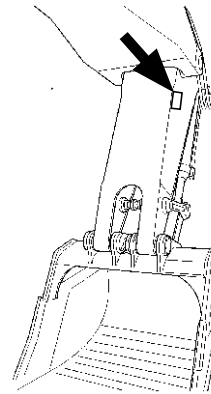

M18C-01-005

Bucket Type and Serial Number (Backhoe)

TYPE: _____

MFG. NO.: _____

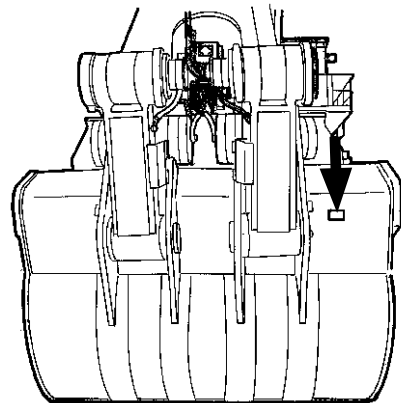

M146-01-020

Control Valve Type and Serial Number

TYPE: _____

MFG. NO. (LEFT): _____

MFG. NO. (MIDDLE): _____

MFG. NO. (RIGHT): _____

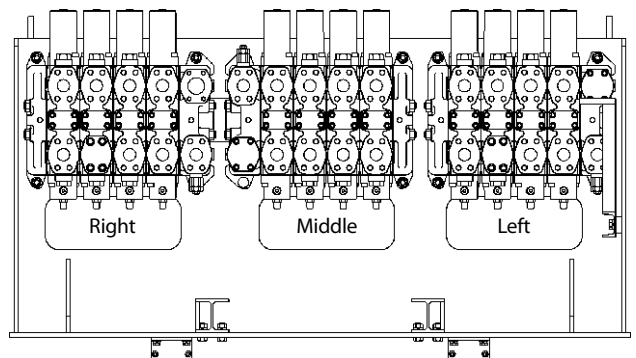

T18C-01-02-005

SAFETY

Recognize Safety Information

- These are the **SAFETY ALERT SYMBOLS**.
 - When you see these symbols on your machine or in this manual, be alert to the potential for personal injury.
 - Follow recommended precautions and safe operating practices.



SA-688

Understand Signal Words

- On machine safety signs, signal words designating the degree or level of hazard - **DANGER**, **WARNING**, or **CAUTION** - are used with the safety alert symbol.
 - **DANGER** indicates an imminently hazardous situation which, if not avoided, will result in death or serious injury.
 - **WARNING** indicates a potentially hazardous situation which, if not avoided, could result in death or serious injury.
 - **CAUTION** indicates a potentially hazardous situation which, if not avoided, may result in minor or moderate injury.
 - **DANGER or WARNING safety signs** are located near specific hazards. General precautions are listed on **CAUTION safety signs**.
 - Some safety signs do not use any of the designated signal words above after the safety alert symbol are occasionally used on this machine.
- To avoid confusing machine protection with personal safety messages, a signal word **IMPORTANT** indicates a situation which, if not avoided, could result in damage to the machine.
-  **NOTE** indicates an additional explanation for an element of information.



SA-1223

SAFETY

Follow Safety Instructions

- Carefully read and follow all safety signs on the machine and all safety messages in this manual.
- Safety signs should be installed, maintained and replaced when necessary.
 - If a safety sign or this manual is damaged or missing, order a replacement from your authorized dealer in the same way you order other replacement parts (be sure to state machine model and serial number when ordering).
- Learn how to operate the machine and its controls correctly and safely.
- Allow only trained, qualified, authorized personnel to operate the machine.
- Keep your machine in proper working condition.
 - Unauthorized modifications of the machine may impair its function and/or safety and affect machine life.
 - Do not modify any machine parts without authorization. Failure to do so may deteriorate the part safety, function, and/or service life. In addition, personal accident, machine trouble, and/or damage to material caused by unauthorized modifications will void Hitachi Warranty Policy.
 - Do not use attachments and/or optional parts or equipment not authorized by Hitachi. Failure to do so may deteriorate the safety, function, and/or service life of the machine. In addition, personal accident, machine trouble, and/or damage to material caused by using unauthorized attachments and/or optional parts or equipment will void Hitachi Warranty Policy.
- The safety messages in this SAFETY chapter are intended to illustrate basic safety procedures of machines. However it is impossible for these safety messages to cover every hazardous situation you may encounter. If you have any questions, you should first consult your supervisor and/or your authorized dealer before operating or performing maintenance work on the machine.

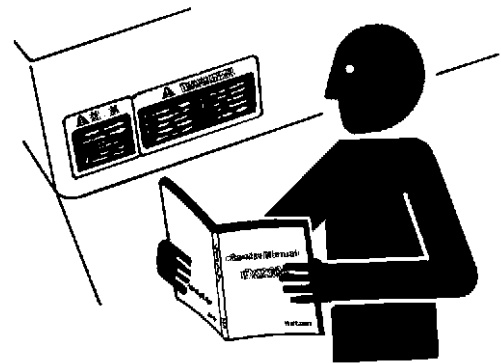

SA-003

SAFETY

Prepare for Emergencies

- Be prepared if a fire starts or if an accident occurs.
 - Keep a first aid kit and fire extinguisher on hand.
 - Thoroughly read and understand the label attached on the fire extinguisher to use it properly.
 - To ensure that a fire extinguisher can be always used when necessary, check and service the fire extinguisher at the recommended intervals as specified in the fire extinguisher manual.
 - Establish emergency procedure guidelines to cope with fires and accidents.
 - Keep emergency numbers for doctors, ambulance service, hospital, and fire department posted near your telephone.



SA-437

Wear Protective Clothing

- Wear close fitting clothing and safety equipment appropriate to the job.

You may need:

- A hard hat
- Safety shoes
- Safety glasses, goggles, or face shield
- Heavy gloves
- Hearing protection
- Reflective clothing
- Wet weather gear
- Respirator or filter mask.

Be sure to wear the correct equipment and clothing for the job. Do not take any chances.

- Avoid wearing loose clothing, jewelry, or other items that can catch on control levers or other parts of the machine.
- Operating equipment safely requires the full attention of the operator. Do not wear radio or music headphones while operating the machine.

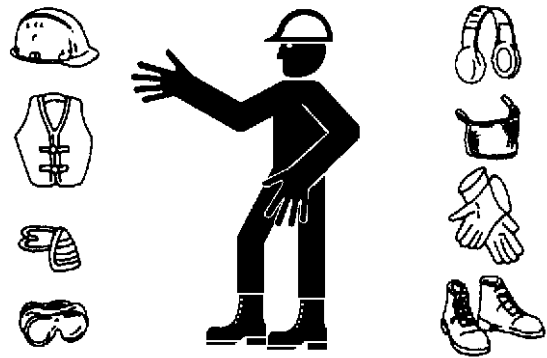

SA-438

Protect Against Noise

- Prolonged exposure to loud noise can cause impairment or loss of hearing.
 - Wear a suitable hearing protective device such as earmuffs or earplugs to protect against objectionable or uncomfortably loud noises.



SA-434

SAFETY

Inspect Machine

- Inspect your machine carefully each day or shift by walking around it before you start it to avoid personal injury.
- In the walk-around inspection, be sure to cover all points described in the “MAINTENANCE” chapter in the operator’s manual.



SA-435

General Precautions for CAB

- Before entering the cab, thoroughly remove all dirt and/or oil such as mud, grease, soil or stones that may mess up the cab from the soles of your work boots. If any controls such as a pedal is operated while with dirt and/or oil on the soles of the operator’s work boots, the operator’s foot may slip off the pedal, possibly resulting in a personal accident.
- Do not mess up around the operator’s seat with parts, tools, soil, stones, obstacles that may fold up or turn over, cans or lunch box. The levers or pedals become inoperable if obstacle jams in operation stroke of the travel levers/pedals, pilot control shut-off lever or control levers/pedals, which may result in serious injury or death.
- Do not leave parts and/or tools lying around the operator’s seat. Store them in their specified locations.
- Avoid storing transparent bottles in the cab. Do not attach any transparent type window decorations on the windowpanes as they may focus sunlight, possibly starting a fire.
- Refrain from listening to the radio, or using music headphones or mobile telephones in the cab while operating the machine.
- Keep all flammable objects and/or explosives away from the machine.
- After using the ashtray, always cover it to extinguish the match and/or tobacco.
- Do not leave cigarette lighters in the cab. When the temperature in the cab increases, the lighter may explode.
- Use proper floor mat dedicated to the machine. If another floor mat is used, it may be displaced and contact with the travel pedals or loader bucket open-close pedals during operation, resulting in serious injury or death.

SAFETY

Use Handholds and Steps

- Falling is one of the major causes of personal injury.
 - When you get on and off the machine, always face the machine and maintain a three-point contact with the steps and handrails.
 - Do not use any controls as handholds.
 - Never jump on or off the machine. Never mount or dismount a moving machine.
 - Be careful of slippery conditions on platforms, steps, and handrails when leaving the machine.
 - Never get on and off the machine with tools in your hands.

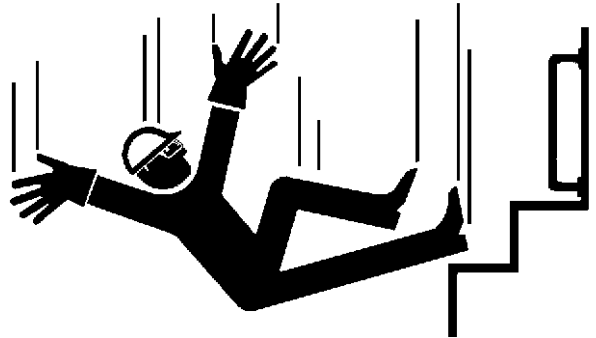

SA-439

Adjust Operator's Seat

- A poorly adjusted seat for either the operator or the work at hand may quickly fatigue the operator leading to misoperations.
 - The seat should be adjusted whenever changing the operator for the machine.
 - The operator should be able to fully depress the pedals and to correctly operate the control levers with his back against the seat back.
 - If not, move the seat forward or backward, and check again.
 - Adjust the rear view mirror position so that the best rear visibility is obtained from the operator's seat. If the mirror is broken, immediately replace it with a new one.



SA-378

Ensure Safety Before Rising from or Leaving Operator's Seat

- Before rising from the operator's seat to open/close either side window or to adjust the seat position, be sure to first lower the front attachment to the ground and then move the pilot control shut-off lever to the LOCK position. Failure to do so may allow the machine to unexpectedly move when a body part unintentionally comes in contact with a control lever or pedal, possibly resulting in serious personal injury or death.
- Before leaving the machine, be sure to first lower the front attachment to the ground and then move the pilot control shut-off lever to the LOCK position. Press and hold the engine stop switch until stopping the engine completely. Remove the key from the key switch.
- Before leaving the machine, close all windows, doors, and access covers and lock them up.

SAFETY

Fasten Your Seat Belt

- If the machine should overturn, the operator may become injured and/or thrown from the cab. Additionally the operator may be crushed by the overturning machine, resulting in serious injury or death.
- Prior to operating the machine, thoroughly examine webbing, buckle and attaching hardware. If any item is damaged or worn, replace the seat belt or component before operating the machine.
- Be sure to remain seated with the seat belt securely fastened at all times when the machine is in operation to minimize the chance of injury from an accident.
- We recommend that the seat belt is replaced every three years regardless of its apparent condition.
- Seat belt is also provided on the trainer's seat. Be sure the rider on the trainer's seat properly fastens seat belt before operating the machine.

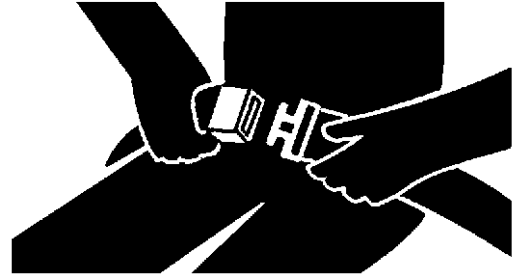

SA-237

Move and Operate Machine Safely

- Bystanders can be run over.
 - Take extra care not to run over bystanders. Confirm the location of bystanders before moving, swinging, or operating the machine.
 - Always keep the travel alarm and horn in working condition (if equipped). It warns people when the machine starts to move.
 - Use a signal person when moving, swinging, or operating the machine in congested areas. Coordinate hand signals before starting the machine.
 - Use appropriate illumination. Check that all lights are operable before operating the machine. If any faulty illumination is present, immediately repair it.
 - Ensure the cab door, windows, doors and covers are securely locked.
 - Check the mirror and the monitors in the CAB for problems. If there are, replace the problem parts or clean the mirror, cameras and monitors. Refer to Camera Monitor section on the cleaning of the camera and monitor.

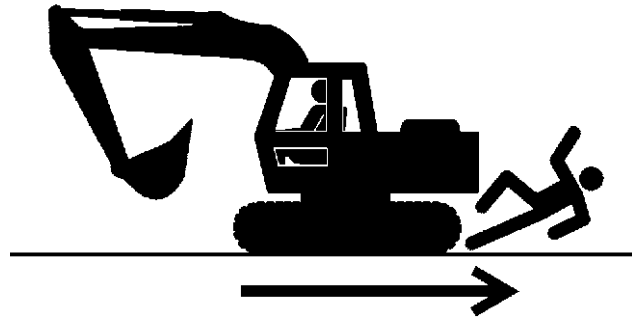

SA-426

Handle Starting Aids Safely

Starting fluid:

- Starting fluid is highly flammable.
 - Keep all sparks and flame away when using it.
 - Keep starting fluid well away from batteries and cables.
 - Remove container from machine if engine does not need starting fluid.
 - To prevent accidental discharge when storing a pressurized container, keep the cap on the container, and store it in a cool, well-protected location.
 - Do not incinerate or puncture a starting fluid container.



SA-293

SAFETY

Operate Only from Operator's Seat

- Inappropriate engine starting procedures may cause the machine to runaway, possibly resulting in serious injury or death.
 - Start the engine only from the operator's seat.
 - Do not start engine by shorting across starter terminals.
 - Before starting the engine, confirm that all control levers are in neutral.
 - Before starting the engine, confirm the safety around the machine and sound the horn to alert bystanders.



SA-444

Jump Starting

- Battery gas can explode, resulting in serious injury.
 - If the engine must be jump started, be sure to follow the instructions shown in the "OPERATING ENGINE" chapter in the operator's manual.
 - The operator must be in the operator's seat so that the machine will be under control when the engine starts. Jump starting is a two-person operation.
 - Never use a frozen battery.
 - Failure to follow correct jump starting procedures could result in a battery explosion or a runaway machine.

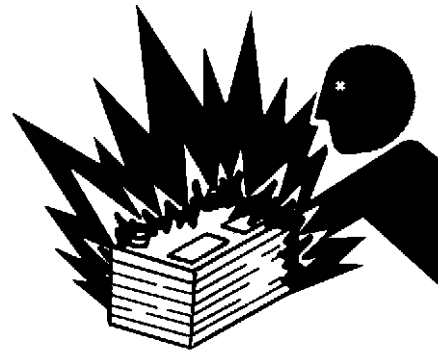

SA-032

SAFETY

Precautions for Operations

- Investigate the worksite before starting operations.
 - Be sure to install an overhead cab guard when operating in a worksite which has a possibility of falling objects.
 - If operation on soft ground is required, sufficiently reinforce the ground beforehand.
 - Be sure to wear close fitting clothing and safety equipment appropriate for the job, such as a hard hat, etc. when operating the machine.
 - Clear all persons and obstacles from area of operation and machine movement.

Always beware of the surroundings while operating.

When working in a small area surrounded by obstacles, take care not to hit the upperstructure against obstacles.

- When loading onto trucks, bring the bucket over the truck beds from the rear side. Take care not to swing the bucket over the cab or over any person.

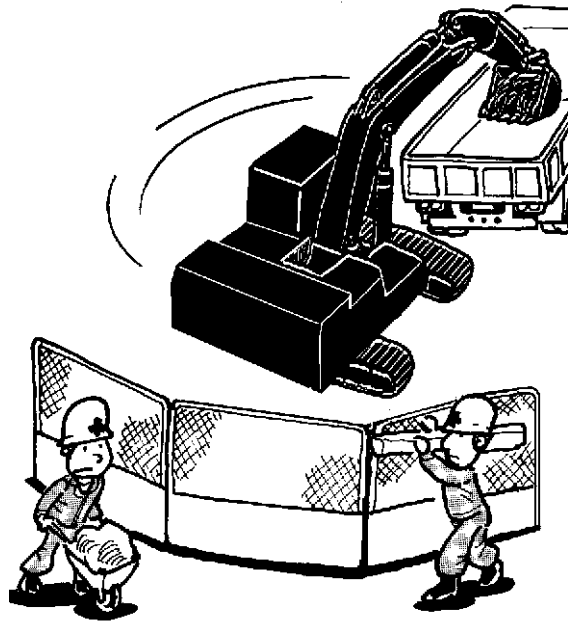

M117-05-006

SAFETY

Investigate Job Site Beforehand

- When working at the edge of an excavation or on a road shoulder, the machine could tip over, possibly resulting in serious injury or death.
- Investigate the configuration and ground conditions of the job site beforehand to prevent the machine from falling and to prevent the ground, stockpiles, or banks from collapsing.
- Make a work plan. Use machines appropriate to the work and job site.
- Reinforce ground, edges, and road shoulders as necessary. Keep the machine well back from the edges of excavations and road shoulders.
- When working on an incline or on a road shoulder, employ a signal person as required.
- When the footing is weak, reinforce the ground before starting work.
- When working on frozen ground, be extremely alert. As ambient temperatures rise, footing becomes loose and slippery.
- Beware the possibility of fire when operating the machine near flammable objects such as dry grass.
- Make sure the worksite has sufficient strength to firmly support the machine.
When working close to an excavation or at road shoulders, operate the machine with the tracks positioned perpendicular to the cliff face with travel motors at the rear, so that the machine can more easily evacuate if the cliff face collapses.
- If working on the bottom of a cliff or a high bank is required, be sure to investigate the area first and confirm that no danger of the cliff or bank collapsing exists. If any possibility of cliff or bank collapsing exists, do not work on the area.
- Soft ground may collapse when operating the machine on it, possibly causing the machine to tip over. When working on a soft ground is required, be sure to reinforce the ground first using large pieces of steel plates strong and firm enough to easily support the machine.
- Note that there is always a possibility of machine tipping over when working on rough terrain or on slopes. Prevent machine tipping over from occurring. When operating on rough terrain or on slopes:
 - Reduce the engine speed.
 - Select slow travel speed mode.
 - Operate the machine slowly and be cautious with machine movements.

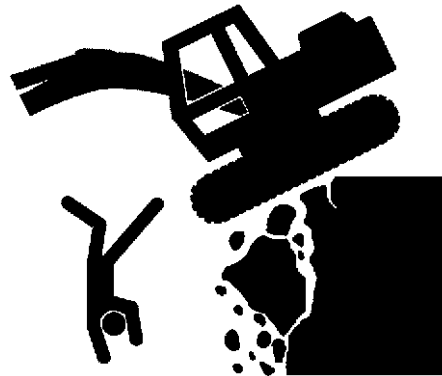

SA-380

SAFETY

Provide Signals for Jobs Involving Multiple Machines

- For jobs involving multiple machines, provide signals commonly known by all personnel involved. Also, appoint a signal person to coordinate the job site. Make sure that all personnel obey the signal person's directions.



SA-481

Confirm Direction of Machine to be Driven

- Incorrect travel pedal/lever operation may result in serious injury or death.
- Before driving the machine, confirm the position of the undercarriage in relation to the operator's position. If the travel motors are located in front of the cab, the machine will move in reverse when travel pedals/levers are operated to the front.

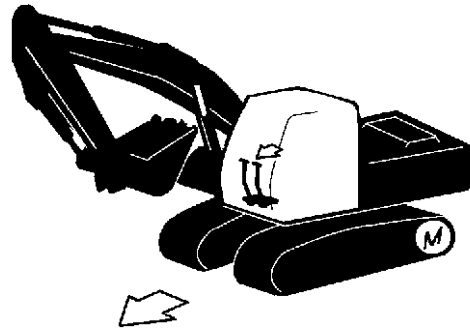

SA-491

Thank you so much for reading.
Please click the “Buy Now!”
button below to download the
complete manual.



After you pay.

You can download the most
perfect and complete manual in
the world immediately.

Our support email:

ebooklibonline@outlook.com