

PART NO. EM1MS-1-3

HITACHI

Operator's Manual

ZAXIS

17U-2

Hydraulic Excavator

Serial No. 012958 and up

INDEX

MACHINE NUMBERS

SAFETY

SAFETY SIGNS

COMPONENTS NAME

OPERATOR'S STATION

BREAK-IN

OPERATING THE ENGINE

DRIVING THE MACHINE

OPERATING THE MACHINE

TRANSPORTING

MAINTENANCE

CONSUMABLE PARTS LIST

MAINTENANCE UNDER SPECIAL ENVIRONMENTAL CONDITIONS

STORAGE

TROUBLESHOOTING

SPECIFICATIONS

REFERENCE

INDEX

CONTENTS

MACHINE NUMBERS

SAFETY

Recognize Safety Information.....	S-1
Understand Signal Words.....	S-1
Follow Safety Instructions.....	S-2
Prepare for Emergencies.....	S-2
Wear Protective Clothing.....	S-3
Protect Against Noise.....	S-3
Inspect Machine.....	S-3
Tidy Up Inside Operator's Space.....	S-4
Use Handholds and Steps.....	S-4
Never Ride Attachment.....	S-4
Adjust the Operator's Seat.....	S-5
Ensure Safety Before Rising from or Leaving Operator's Seat.....	S-5
Fasten Your Seat Belt.....	S-5
Move and Operate Machine Safely.....	S-6
Operate Only from Operator's Seat.....	S-7
Jump Starting.....	S-7
Keep Riders off Machine.....	S-7
Precautions for Operations.....	S-8
Investigate Job Site Beforehand.....	S-9
Equipment of OPG.....	S-10
Provide Signals for Jobs Involving Multiple Machines.....	S-10
Confirm Direction of Machine to be Driven.....	S-10
Drive Machine Safely.....	S-11
Avoid Injury from Rollaway Accidents.....	S-13
Avoid Injury from Back-Over and Swing Accidents.....	S-14
Keep Personnel Clear from Working Area.....	S-15
Never Position Bucket Over Anyone.....	S-15
Avoid Undercutting.....	S-15
Avoid Tipping.....	S-16
Never Undercut a High Bank.....	S-16
Dig with Caution.....	S-17
Operate with Caution.....	S-17
Avoid Power Lines.....	S-17
Precautions for Lightning.....	S-18
Do Not Use for Craning Operations.....	S-18
Protect Against Flying Debris.....	S-18
Park Machine Safely.....	S-19
Handle Fluids Safely --- Avoid Fires.....	S-19
Safety Transporting.....	S-20
Practice Safe Maintenance.....	S-21
Warn Others of Service Work.....	S-22
Support Machine Properly.....	S-22
Stay Clear of Moving Parts.....	S-23
Prevent Parts from Flying.....	S-23
Store Attachments Safely.....	S-24
Prevent Burns.....	S-24
Replace Rubber Hoses Periodically.....	S-25
Avoid High-Pressure Fluids.....	S-25
Prevent Fires.....	S-26
Evacuating in Case of Fire.....	S-28

Beware of Exhaust Fumes.....	S-28
Beware of Asbestos and Silicon Dust and Other Contamination.....	S-28
Precautions for Welding and Grinding.....	S-29
Avoid Heating Near Pressurized Fluid Lines.....	S-29
Avoid Applying Heat to Lines Containing Flammable Fluids.....	S-29
Remove Paint Before Welding or Heating.....	S-30
Prevent Battery Explosions.....	S-30
Handle Chemical Products Safely.....	S-31
Dispose of Waste Properly.....	S-31

SAFETY SIGNS.....	S-33
--------------------------	-------------

COMPONENTS NAME.....	1-1
-----------------------------	------------

OPERATOR'S STATION

Pedals, Levers and Monitor Panel.....	1-2
Key Switch.....	1-3
Switch Panel.....	1-3
Monitor Panel.....	1-4
Alternator Indicator.....	1-4
Fuel Level Indicator.....	1-4
Preheat Indicator.....	1-4
Overheat Indicator.....	1-4
Engine Oil Pressure Indicator.....	1-5
Hour Meter.....	1-5
Fuel Gauge.....	1-5
Coolant Temperature Gauge.....	1-5
Fast Travel Mode Indicator.....	1-5
Cab Heater Operation (Cab equipped machines).....	1-6
Radio (Cab equipped machines).....	1-7
AM/FM Radio Operation.....	1-8
Door Opening Lock System.....	1-10
Opening/Closing Cab Front Window (Cab equipped machines).....	1-11
Emergency Exit (Cab equipped machines).....	1-12
Adjusting Operator's Seat.....	1-13
Tool and Operator's Manual Boxes.....	1-13
Seat Belt.....	1-14
Cab Light (Cab equipped machines).....	1-14
Removing and Installing Cab Door.....	1-15

BREAK-IN

Breaking in New Machine.....	2-1
------------------------------	-----

OPERATING THE ENGINE

Before Starting Engine.....	3-1
Starting Engine.....	3-2
Starting in Cold Weather.....	3-3
Check Machine After Starting Engine.....	3-4
Using Booster Battery.....	3-5
Stopping the Engine.....	3-6

CONTENTS

DRIVING THE MACHINE

Travel Levers	4-1
Travel Mode Pedal.....	4-3
Travel Alarm	4-3
Traveling on Soft Ground	4-4
Raise One Track Using Boom and Arm	4-4
Towing Machine.....	4-5
Driving in Water or on Soft Ground	4-6
Parking and Stopping on Slopes	4-7
Parking on Slopes.....	4-7

OPERATING THE MACHINE

Control Lever (ISO Excavator Pattern).....	5-1
Control Lever (H-Pattern: Hitachi Excavator Pattern)	5-2
Control Lever (SAE-Backhoe Pattern) --- If Equipped (2 Way Multi Valve)	5-3
Boom-Swing Pedal	5-4
Auxiliary Pedal (Optional)	5-5
Blade Lever.....	5-6
Precautions for Blade Operation	5-7
Side Frame Extend/Retract Lever	5-8
Pilot Control Shut-off Lever.....	5-10
Warming Up Operation.....	5-11
Warming Up in Cold Weather	5-11
Operating Backhoe.....	5-12
Grading Operation	5-13
Avoid Driving Bucket Teeth Into Ground	5-13
Avoid Abusive Operation	5-13
Avoid Striking with Bucket	5-14
Avoid Excavation Using Upperstructure and/or Boom Swing Power	5-14
Use Correct Track Shoe.....	5-14
Avoid Other than Specified Machine Operations	5-15
Precautions for Using Bucket Hook.....	5-16
Boom Cylinder May Hit Blade	5-16
Shackle Bracket Usage	5-17
Avoid Hitting Blade with Bucket	5-18
Avoid Colliding Blade Against Rocks.....	5-18
Avoid Colliding Boom Cylinder with Track	5-18
Using Rubber Crawler	5-19
Hydraulic Breaker (Optional)	5-21
Crusher Operation (Optional)	5-24
Precautions for After Operating the Machine	5-25
Emergency Boom Lowering Procedure	5-26

TRANSPORTING

Transporting by Road	6-1
Trailer Loading/Unloading.....	6-1
Loading	6-2
Securing the Machine to the Trailer for Transportation (Machines without Lightweight Object-Towing Bracket Provided).....	6-3

Securing the Machine to the Trailer for Transportation (Machines with Lightweight Object-Towing Bracket Provided)	6-4
Unloading	6-5
Lifting Machine with Crane	6-6

MAINTENANCE

Procedures.....	7-1
Prepare Machine for Inspection/Maintenance.....	7-2
Opening/Closing Engine Access Covers	7-3
Opening/Closing Right Side Covers.....	7-4
Daily Inspection	7-5
Periodic Replacement of Parts	7-6
Maintenance Guide	7-7
The Brand Names of Recommended Oils and Lubricants	7-10
A. Greasing	7-11
Front Joint Pins	7-11
Bucket and Link Pins	7-14
Swing Bearing	7-15
Swing Internal Gear	7-16
Control Lever Universal Joint.....	7-16
B. Engine	7-17
Engine Oil.....	7-17
Change Engine Oil.....	7-17
Replace Engine Oil Filter	7-17
C. Transmission	7-19
Travel Reduction Gear.....	7-19
D. Hydraulic System	7-21
Inspection and Maintenance of Hydraulic Equipment.....	7-21
Check Hydraulic Oil Level.....	7-22
Drain Hydraulic Oil Tank Sump.....	7-23
Change Hydraulic Oil	7-24
Clean Suction Filter.....	7-26
Replace Full-Flow Filter	7-27
Replace Pilot Filter	7-28
Check Hoses and Lines	7-30
E. Fuel System	7-34
Check Water Separator	7-35
Drain Fuel Tank Sump	7-35
Replace Fuel Filter	7-36
Check Fuel Hoses.....	7-37
F. Air Cleaner	7-38
Clean the Air Cleaner Element	7-38
Replace the Air Cleaner Elements.....	7-38
G. Cooling System	7-39
Check Coolant Level.....	7-40
Check and Adjust Fan Belt Tension	7-40
Change Coolant	7-42
Clean Radiator	7-43
H. Electrical System	7-44
Battery.....	7-44
Replacing Fuses	7-47
I. Miscellaneous	7-48

CONTENTS

Check Bucket Teeth for Looseness and/or Wear	7-48
Replace Bucket	7-50
Adjust Track Sag (Rubber Crawler) and Check for Damage	7-51
Replace Rubber Track	7-53
Check Track Sag (Steel Crawler) (Optional).....	7-55
Check and Replace Seat Belt.....	7-58
Check Bucket Hook (Optional).....	7-58
Clean Cab Floor (Cab equipped machines)	7-59
Check Injection Nozzle	7-60
Adjust Valve Clearance	7-60
Check and Clean Injection Device	7-60
Measure Engine Compression Pressure.....	7-60
Check Starter and Alternator	7-60
Check Radiator Cap	7-60
Check Tightening Torque of Bolts and Nuts ...	7-61
CONSUMABLE PARTS LIST	8-1
MAINTENANCE UNDER SPECIAL ENVIRONMENTAL CONDITIONS	9-1
STORAGE	
Storing the Machine.....	10-1
Removing the Machine from Storage.....	10-2
TROUBLESHOOTING	
Engine	11-1
Electrical System	11-1
Hydraulic System	11-2
SPECIFICATIONS	
Specifications	12-1
Working Ranges	12-2
Shoe Types and Applications	12-3
Bucket Types and Applications.....	12-4
REFERENCE	
Additional Counterweight.....	13-1
INDEX	14-1

MACHINE NUMBERS

The manufacturing Nos. explained in this group is the individual number (serial No.) given to each machine and hydraulic components. These numbers are requested when inquiring any information on the machine and/or components. Fill these serial Nos. in the blank spaces in this group to immediately make them available upon request.

MACHINE

MODEL/TYPE: _____

PRODUCT
IDENTIFICATION
NUMBER: _____

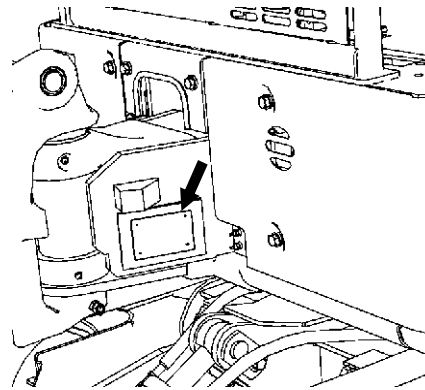

 NOTE:

_____ Marks to indicate the start and end of the PIN
HCM1MS00X00010001

_____ PRODUCT IDENTIFICATION
NUMBER (PIN)

M1MS-00-001

SAFETY

RECOGNIZE SAFETY INFORMATION

- These are the **SAFETY ALERT SYMBOLS**.
 - When you see these symbols on your machine or in this manual, be alert to the potential for personal injury.
 - Follow recommended precautions and safe operating practices.

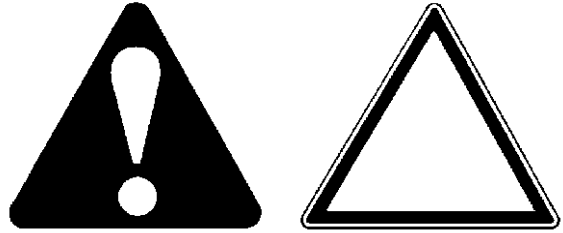

SA-688

UNDERSTAND SIGNAL WORDS

- On machine safety signs, signal words designating the degree or level of hazard - **DANGER**, **WARNING**, or **CAUTION** - are used with the safety alert symbol.
 - **DANGER** indicates an imminently hazardous situation which, if not avoided, will result in death or serious injury.
 - **WARNING** indicates a potentially hazardous situation which, if not avoided, could result in death or serious injury.
 - **CAUTION** indicates a potentially hazardous situation which, if not avoided, may result in minor or moderate injury.
 - **DANGER** or **WARNING** safety signs are located near specific hazards. General precautions are listed on **CAUTION** safety signs.
 - Some safety signs don't use any of the designated signal words above after the safety alert symbol are occasionally used on this machine.
- To avoid confusing machine protection with personal safety messages, a signal word **IMPORTANT** indicates a situation which, if not avoided, could result in damage to the machine.
-  **NOTE** indicates an additional explanation for an element of information.



SA-1223

SAFETY

FOLLOW SAFETY INSTRUCTIONS

- Carefully read and follow all safety signs on the machine as well as all safety messages in this manual.
- Safety signs must be installed, maintained and replaced if damaged.
 - If a safety sign or this manual is damaged or missing, order a replacement from your authorized dealer in the same way you order other replacement parts (be sure to state machine model and serial number when ordering).
- Allow only properly trained, qualified, authorized personnel to operate the machine.
- Learn how to correctly operate and service the machine.
- Keep your machine in proper working condition.
- Always operate the machine within the specification.
 - Unauthorized modifications of the machine may impair the functions and/or safety and affect machine life and the warranty will become void.
- The safety messages in this SAFETY chapter are intended to illustrate basic safety procedures of machines. However it is impossible for these safety messages to cover every possible hazardous situation you may encounter. If you have any questions concerning safety, you should first consult your supervisor and/or your authorized dealer before operating or performing maintenance work on the machine.

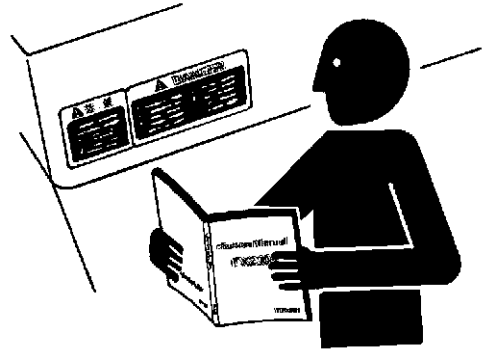

SA-003

PREPARE FOR EMERGENCIES

- Be prepared if a fire starts or if an accident occurs.
 - Keep a first aid kit and fire extinguisher on hand.
 - Thoroughly read and understand the label attached on the fire extinguisher and use it properly.
 - To ensure that a fire-extinguisher can be always used when necessary, check and service the fire-extinguisher at the recommended intervals as specified in the fire-extinguisher manual.
 - Establish emergency procedure guidelines to cope with any fire or accidents which may occur.
 - Keep emergency numbers for doctors, ambulance service, hospitals, and fire department posted near your telephone.

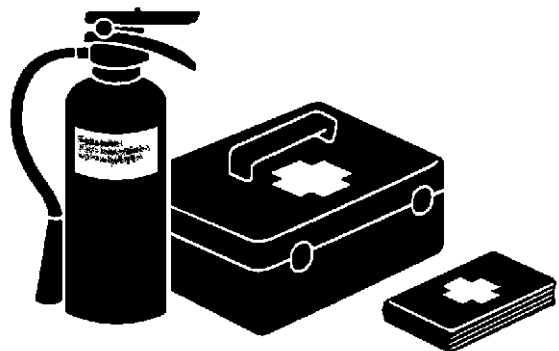

SA-437

SAFETY

WEAR PROTECTIVE CLOTHING

- Wear close fitting clothing and safety equipment appropriate to the job.

You may need:

- A hard hat
- Safety belt
- Safety shoes
- Safety glasses, goggles, or face shield
- Heavy gloves
- Hearing protection
- Reflective clothing
- Wet weather gear
- Respirator or filter mask.

Be sure to wear the correct equipment and clothing for the job. Do not take any chances.

- Avoid wearing loose clothing, jewelry, or other items that can catch on control levers or other parts of the machine.
- Operating equipment safely requires the full attention of the operator.
- Do not wear radio or music headphones while operating the machine.

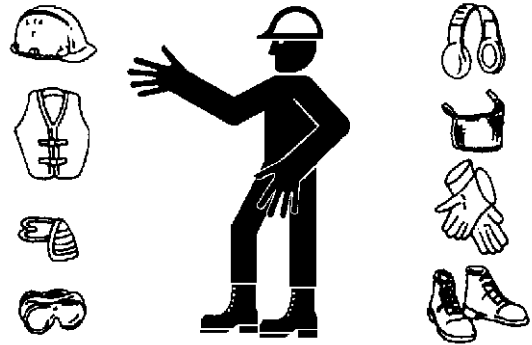

SA-438

PROTECT AGAINST NOISE

- Prolonged exposure to loud noise can cause impairment or loss of hearing.
- Wear a suitable hearing protective device such as earmuffs or earplugs to protect against objectionable or uncomfortably loud noises.



SA-434

INSPECT MACHINE

- If any abnormality is found, be sure to repair it immediately before operating the machine.
- In the walk-around inspection, be sure to cover all points described in the “PRE-START INSPECTION” chapter in the operator’s manual.



SA-435

SAFETY

TIDY UP INSIDE OPERATOR'S SPACE

- Always keep inside the operator's space clean by observing instructions below, to prevent any personal accidents from occurring.
- Remove mud and/or oily material from the shoe soles before entering the operator's space. If pedals are operated without removing mud or oily matter, the foot may slip off the pedal, possibly creating a hazardous situation.
- Do not leave parts and/or tools around the operator's seat.
- Avoid storing transparent bottles in the cab. Do not attach any transparent type window decorations on the windowpanes as they may focus sunlight, possibly starting a fire.
- Do not wear radio or music headphones and do not use a cell phone while traveling or operating the machine.
- Never allow hazardous materials such as combustible and/or explosive material in the operator's space.
- Do not leave cigarette lighters in the cab. If the temperature in the cab increases, the lighter may explode.

USE HANDHOLDS AND STEPS

- Falling is one of the major causes of personal injury.
 - When you get on and off the machine, always face the machine.
 - Maintain a three-point contact with the steps and handrails.
 - Do not use any controls as handholds.
 - Never jump on or off the machine. Never mount or dismount a moving machine.
 - In case adhered slippery material such as oil, grease, or mud is present on steps, handrails, or platforms, thoroughly remove such material.

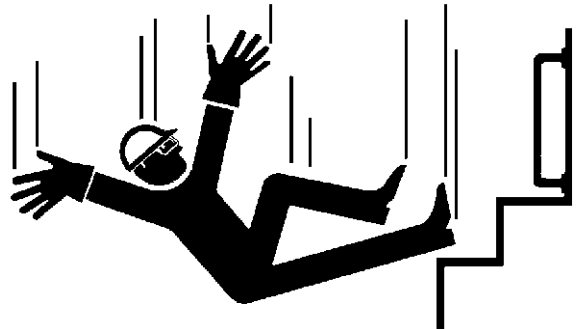

SA-439

NEVER RIDE ATTACHMENT

- Never allow anyone to ride attachments or the load. This is an extremely dangerous practice.

SAFETY

ADJUST THE OPERATOR'S SEAT

- A poorly adjusted seat for either the operator or the work at hand may quickly fatigue the operator leading to mis-operation of the machine.
- The seat should be adjusted whenever the operator for the machine changes.
- The operator should be able to fully depress the pedals and to correctly operate the control levers with his back firmly against the seat back.
- If not, readjust the seat forward or backward, and check again.



SA-378

ENSURE SAFETY BEFORE RISING FROM OR LEAVING OPERATOR'S SEAT

- Before rising from the operator's seat to open/close either side window or to adjust the seat position, be sure to first lower the front attachment to the ground and then move the pilot control shut-off lever to the LOCK position. Failure to do so may allow the machine to unexpectedly move when a body part unintentionally comes in contact with a control lever, possibly resulting in serious personal injury or death.
- Before leaving the machine, be sure to first lower the front attachment to the ground and then move the pilot control shut-off lever to the LOCK position. Turn the key switch OFF to stop the engine.
- Before leaving the machine, close all windows, doors, and access covers and lock them up.

FASTEN YOUR SEAT BELT

- If the machine should overturn, the operator may become injured and/or thrown from the cab. Additionally the operator may be crushed by the overturning machine, resulting in serious injury or death.
- Be sure to remain seated with the seat belt securely fastened whenever operating the machine.
- Prior to operating the machine, thoroughly examine webbing, buckle and attaching hardware. If any item is damaged or worn, replace the seat belt or component before operating the machine. Replace the seat belt at least once every 3 years regardless of appearance

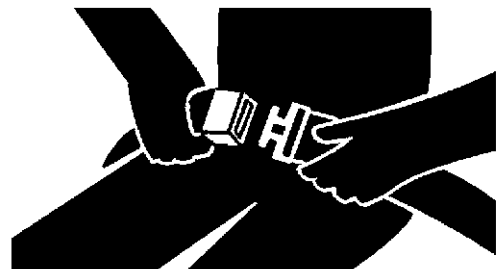

SA-237

SAFETY

MOVE AND OPERATE MACHINE SAFELY

- Always be aware that there is a potential danger around the machine while operating the machine.
- Take extra care not to run over bystanders. Confirm the location of bystanders before moving, swinging, or operating the machine.
- Always keep the travel alarm and horn in working condition (if equipped).
- Before starting to move or operate the machine, sound the travel alarm and horn to alert bystanders.
- Use a signal person when moving, swinging, or operating the machine in congested areas. Locate the signal person so that the operator can always witness the signal person.
- Coordinate the meanings of all safety signs, hand signals and marks before starting the machine. Appoint a person who is responsible to make a signal and/or guidance.
- Never allow any persons or obstacles to enter the machine operation areas.
- Use appropriate illuminations.

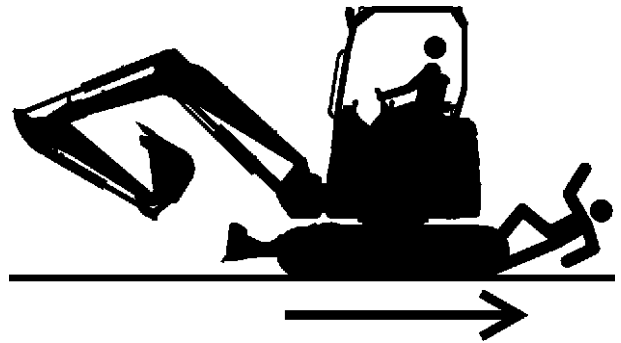

SA-1291

SAFETY

OPERATE ONLY FROM OPERATOR'S SEAT

- Inappropriate engine starting procedures may cause the machine to runaway, possibly resulting in serious injury or death.
- Start the engine only when seated in the operator's seat.
- NEVER start the engine while standing on the tracks or on ground.
- Do not start engine by shorting across starter terminals. A hazardous situation may be created and/or possible damage to the machine may result.
- Before starting the engine, confirm that all control levers are in neutral.

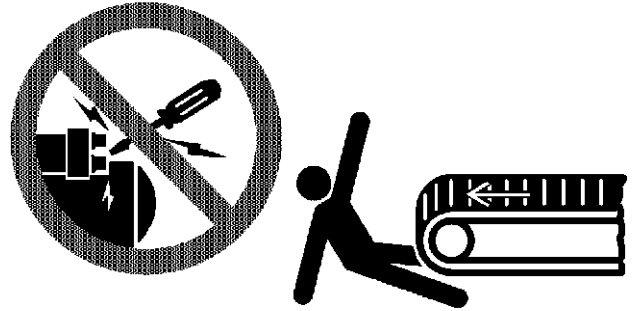

SA-444

JUMP STARTING

- Failure to follow correct jump starting procedures could result in a battery explosion or a runaway machine.
- If the engine must be jump started, be sure to follow the instructions shown in the "OPERATING THE ENGINE" chapter.
- The operator must be seated in the operator's seat so that the machine will be under control when the engine starts. Jump starting is a two-person operation.
- Never use a frozen battery.
- Failure to follow correct jump starting procedures could result in a battery explosion or a runaway machine.

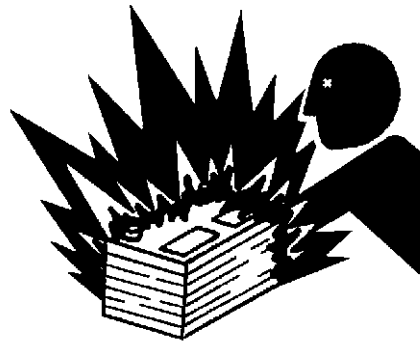

SA-032

KEEP RIDERS OFF MACHINE

- Riders on machine are subject to injury such as being struck by foreign objects and being thrown off the machine.
- Riders also obstruct the operator's view, resulting in the machine being operated in an unsafe manner.
- Only allow the operator is allowed on the machine. Keep riders off.



SA-1292

SAFETY

PRECAUTIONS FOR OPERATIONS

⚠ WARNING: Thoroughly make certain safety at the work site before starting operations. Especially always observe the following points.

- Be sure to install the overhead cab guard before operating the machine in areas where the possibility of falling stones or debris exists.
- If operation on soft ground is required, sufficiently reinforce the ground beforehand.
- Be sure to wear close fitting clothing and required safety items, such as a hard hat, when operating the machine.
- Keep all bystanders and unnecessary objects out of and away from the machine working areas. Always beware of the surroundings while operating the machine. Take care not to allow the rear part of the upperstructure to come in contact with objects when swinging the machine in a small area.
- When loading a dump truck, bring the bucket from the rear side of the dump truck to avoid moving the bucket over the dump truck cab or over any co-workers.

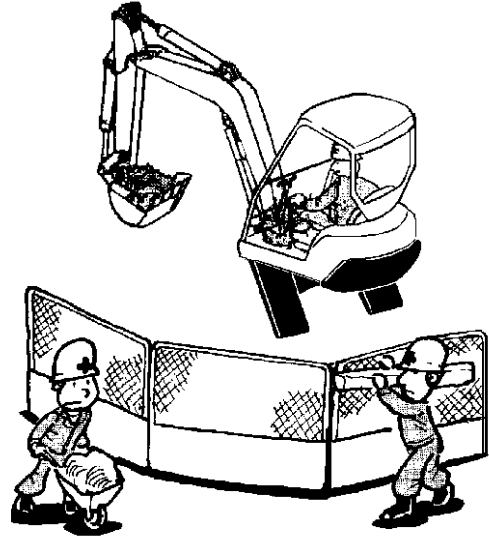

M586-12-012

SAFETY

INVESTIGATE JOB SITE BEFOREHAND

- When working at the edge of an excavation or on a road shoulder, the machine could tip over due to collapse of the ground, possibly resulting in serious injury or death.
 - Investigate the configuration and ground conditions of the job site beforehand to prevent the machine from falling and to prevent the ground, stockpiles, or banks from collapsing.
 - Make a work plan. Use machines appropriate to the work and job site.
 - Reinforce ground, edges, and road shoulders as necessary. Keep the machine well back from the edges of excavations and road shoulders.
 - When working on an incline or on a road shoulder, employ a signal person as required.
 - Never allow bystanders to enter the working area such as swing radius or traveling range.
 - When the footing is weak, reinforce the ground before starting work.
 - When working on frozen ground, be extremely alert. As ambient temperatures rise, footing may become loose and slippery.
 - When operating the machine near open flame, sparks, and/or dead grass, a fire may easily break out. Use special care not to cause a fire.
 - Make sure the work site ground has sufficient strength to firmly support the machine. When working close to an excavation or on road shoulders, operate the machine with the tracks positioned perpendicular to the cliff face with travel motors at the rear and with the blade at the front, so that the machine can more easily evacuate if the cliff face collapses.
- If working at the bottom of a cliff or on a high bank is required, be sure to investigate the area first and confirm that no danger of the cliff or bank collapsing exists. If any possibility of cliff or bank collapsing exists, do not work in that area.
- Soft ground may collapse when operating the machine on it, possibly causing the machine to tip over. When working on a soft ground is required, be sure to reinforce the ground first using large pieces of steel plates strong enough and firm to easily support the machine.
- Note that there is always a possibility of machine tipping over when working on rough terrain or on slopes. Prevent machine tipping over from occurring. Operate the machine slowly to ensure safe operation.

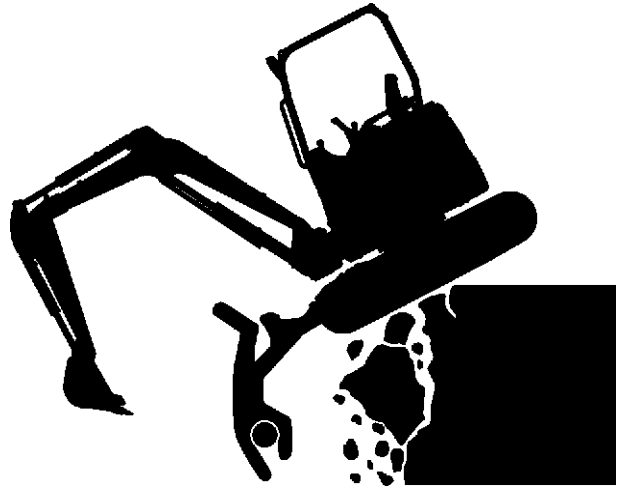

SA-1293

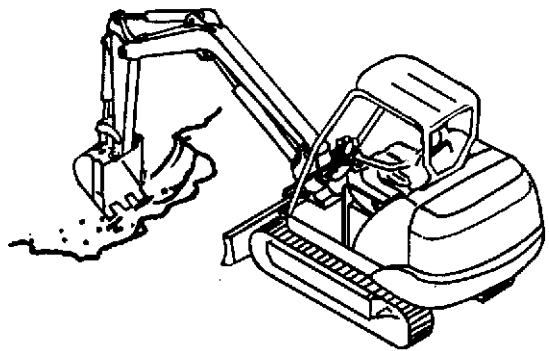

M586-05-021

SAFETY

EQUIPMENT OF OPG

- In case the machine is operated in areas where the possibility of falling stones or debris exists, equip genuine Hitachi OPG guard. Contact your nearest Hitachi dealer for installation method of the OPG guard. Depending on the specifications applied to your machine, modification of the machine to meet ROPS standards will be possible.
- To maintain unimpaired operator protection and manufacturer's protective structure.
 - Damaged ROPS, OPG GUARD must be replaced, not repaired or revised.
 - Any alternation to the ROPS or OPG GUARD must be approved by the manufacturer.

ROPS : Roll Over Protective Structure

OPG : Operator Protective Guard

PROVIDE SIGNALS FOR JOBS INVOLVING MULTIPLE MACHINES

- In case more than one machine is operated in the same job site, accidental collision between machines may cause serious injury or death.
- For jobs involving multiple machines, provide signals commonly known by all personnel involved. Also, appoint a signal person to coordinate the job site. Make sure that all personnel obey the signal person's directions.



SA-481

CONFIRM DIRECTION OF MACHINE TO BE DRIVEN

- Incorrect travel pedal/lever operation may result in serious injury death.
 - Before driving the machine, confirm the position of the undercarriage in relation to the operator's position.
 - If the travel motors are located towards the front of the cab, the machine will move in the reverse direction when travel pedals/levers are operated.

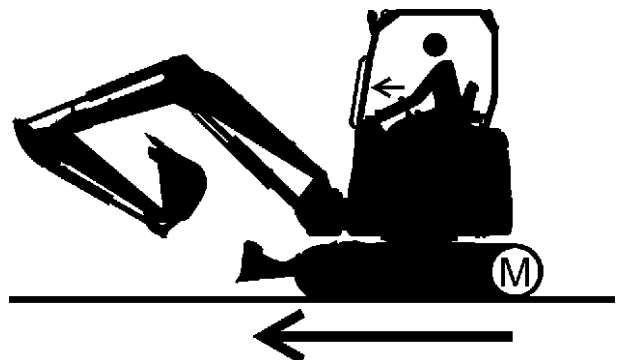

SA-1294

SAFETY

DRIVE MACHINE SAFELY

- Driving the machine in the incorrect direction may result in serious injury or death and/or severe damage to property.
- Before driving the machine, always confirm that the travel pedals/levers direction corresponds to the direction you wish to drive.
 - Be sure to detour around any obstructions.
 - Avoid traveling over obstructions. Soil, fragments of rocks, and/or metal pieces may scatter around the machine. Do not allow personnel to stay around the machine while traveling.
- Driving on a slope may cause the machine to slip or overturn, possibly resulting in serious injury or death.
 - Never attempt to ascend or descend 25 degrees or steeper slopes.
 - Be sure to fasten the seat belt.
 - When driving up or down a slope, keep the bucket facing the direction of travel, approximately 200 to 300 mm (8 to 12 in) (A) above the ground.
 - If machine starts to skid or becomes unstable, immediately lower the bucket to the ground and stop.
- Driving across the face of a slope or steering on a slope may cause the machine to skid or turnover. If the direction must be changed, move the machine to level ground, then, change the direction to ensure safe operation.

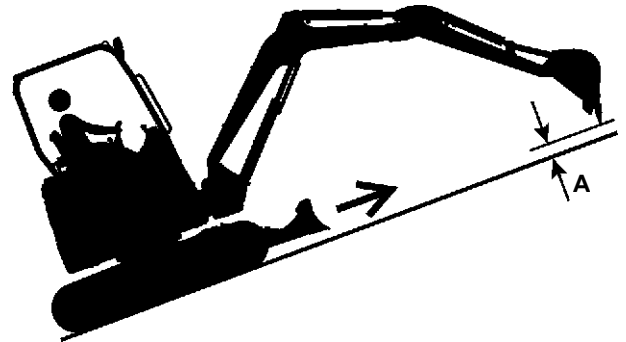

SA-1295

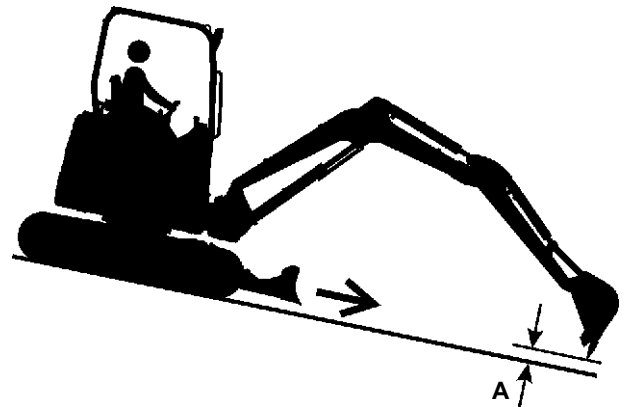

SA-1296

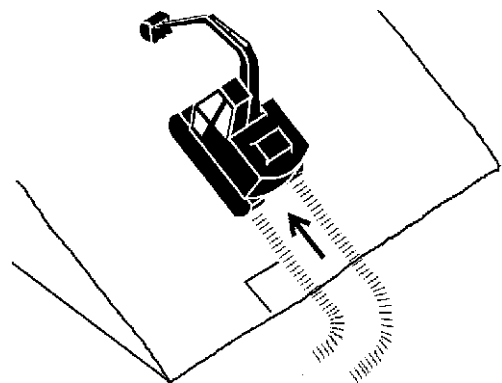

SA-441

WRONG

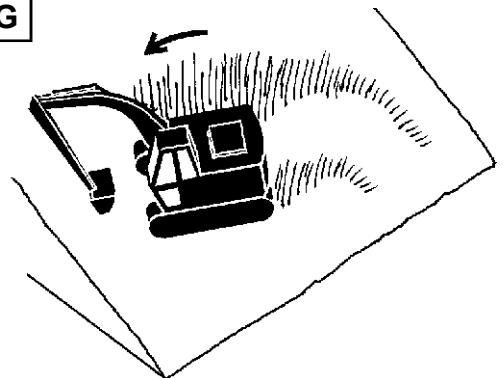

SA-442

SAFETY

- Traveling down a slope in the fast mode requires a longer time to stop the machine. When traveling down a slope, place engine control lever (1) in the slow idle position.
- Driving across the face of a slope or steering on a slope may cause the machine to skid or turnover. If the direction must be changed, move the machine to level ground, then, change the direction to ensure safe operation.
- Avoid swinging the upperstructure on slopes. Never attempt to swing the upperstructure downhill. The machine may tip over. If swinging uphill is unavoidable, carefully operate the upperstructure and boom at slow speed.
- If the engine stalls on a slope, immediately lower the bucket to the ground. Return the control levers to neutral. Then, restart the engine.
- Be sure to thoroughly warm up the machine before ascending steep slopes. If hydraulic oil has not warmed up sufficiently, sufficient performance may not be obtained.
- Use a signal person when moving, swinging or operating the machine in congested areas. Coordinate hand signals before starting the machine.
- Before moving machine, determine which way to move travel pedals/levers for the direction you want to go. When the travel motors are in the rear, pushing down on the front of the travel pedals or pushing the levers forward moves the machine forward, towards the idlers.
- Select a travel route that is as flat as possible. Steer the machine as straight as possible, making small gradual changes in direction.
- Before traveling on them, check the strengths of bridges and road shoulders, and reinforce if necessary.
- When the machine is equipped with steel shoes, cover the road surface with wood plates in order not to damage the road surface. Be careful of steering when operating on asphalt roads in summer.
- Do not make contact with electric wires or bridges.
- When crossing a river, measure the depth of the river using the bucket, and cross slowly. Do not cross the river when the depth of the river is deeper than the upper edge of the upper roller.
- When traveling on rough terrain, reduce engine speed. Select slow travel speed. Slower speed will reduce possible damage to the machine.
- Avoid operations that may damage the track and undercarriage components.
- During freezing weather, always clean snow and ice from track shoes before driving the machine on snowy and/or frozen roads, or loading and unloading the machine for transportation, to prevent the machine from slipping.

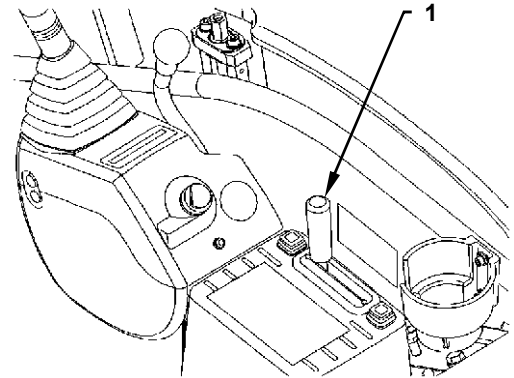

M1MW-04-002

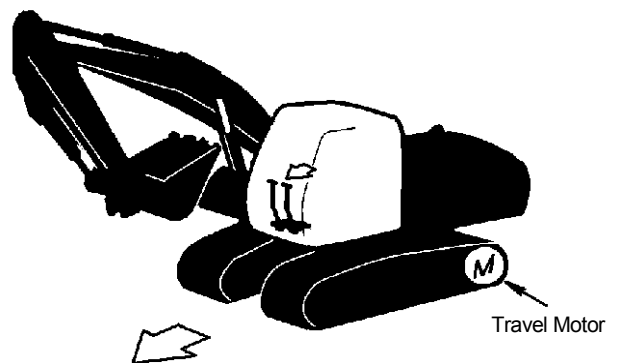

M104-05-008

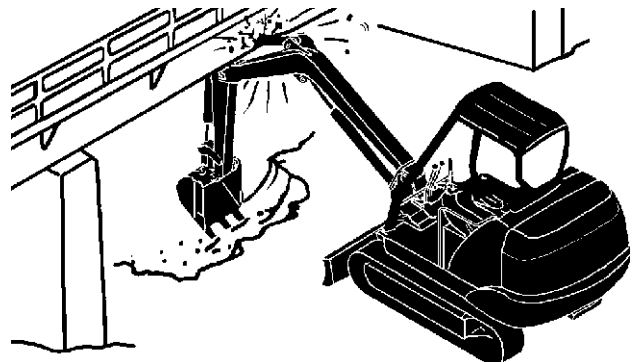

SA-673

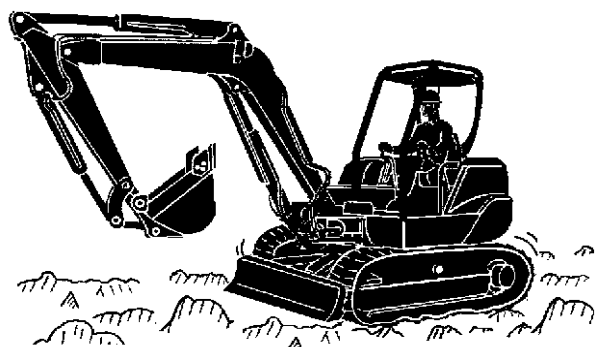

M586-05-002

SAFETY

AVOID INJURY FROM ROLLAWAY ACCIDENTS

- Death or serious injury may result if you attempt to mount or try to bodily stop a moving machine.
- Park the machine in compliance with the safe parking procedures described on page S-19 to prevent the machine from running away.
 - Block both tracks and lower the bucket to the ground, thrust the bucket teeth into the ground if you must park on a grade.
 - Park at a reasonable distance from other machines.

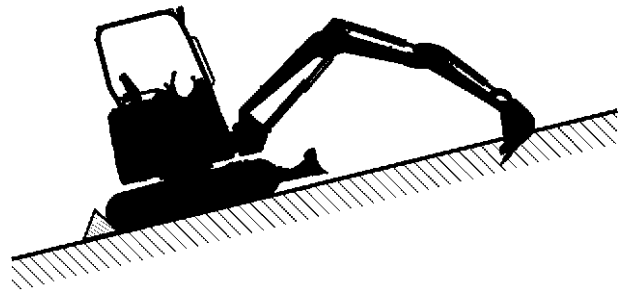

SA-1297

SAFETY

AVOID INJURY FROM BACK-OVER AND SWING ACCIDENTS

- If any person is present near the machine when backing or swinging the upperstructure, the machine may hit or run over that person, resulting in serious injury or death.

To avoid back-over and swing accidents:

- Always look around **BEFORE YOU BACK UP AND SWING THE MACHINE**. BE SURE THAT ALL BYSTANDERS ARE CLEAR.
- Keep the travel alarm in working condition (if equipped). ALWAYS BE ALERT FOR BYSTANDERS MOVING INTO THE WORK AREA. USE THE HORN OR OTHER SIGNAL TO WARN BYSTANDERS BEFORE MOVING MACHINE.
- USE A SIGNAL PERSON WHEN BACKING UP IF YOUR VIEW IS OBSTRUCTED. ALWAYS KEEP THE SIGNAL PERSON IN VIEW. Use hand signals, which conform to your local regulations, when work conditions require a signal person.
- No machine motions shall be made unless signals are clearly understood by both signalman and operator.
- Learn the meanings of all flags, signs, and markings used on the job and confirm who has the responsibility for signaling.
- Keep windows, mirrors, and lights clean and in good condition.
- Dust, heavy rain, fog, etc., can reduce visibility. As visibility decreases, reduce speed and use proper lighting.
- Read and understand all operating instructions in the operator's manual.

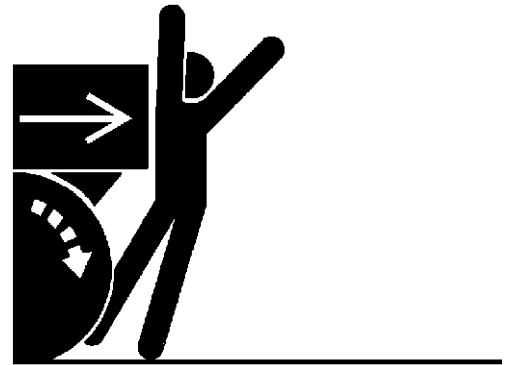

SA-383



SA-384

021-E01A-0494-8

Thank you so much for reading.
Please click the “Buy Now!”
button below to download the
complete manual.



After you pay.

You can download the most
perfect and complete manual in
the world immediately.

Our support email:

ebooklibonline@outlook.com