

編 番
PART NO.
PI2V-EI-3

PARTS CATALOG
パーツカタログ

EX120-3

EQUIPMENT COMPONENTS PARTS

機器インナーパーツ

適用号機 40001～
Serial No.

HITACHI

適 用 製 番 MACHINE Mfg. No.	
エ ン ジ ン 型 式 ENGINE TYPE	
エ ン ジ ン 製 番 ENGINE Mfg. No.	
備 考 REMARKS	

FOREWORD

- ◎ This parts catalog shows the precision parts of EX120-3 Hydraulic Excavator.
The numerical parts No. index is provided at the end of this parts catalog.
In the parts index, a part No. with "*" mark shows a newly added part on the parts catalog.
- ◎ This parts catalog contains the most recent information available at the time of printing, and the contents of the list are based on information in effect at that time and are subject to change without notice.
- ◎ The references in the parts catalog of "LEFT", "RIGHT", "FRONT" and "REAR" are identified as follows.
The driver's seat is positioned "LEFT" side, and the opposite side is "RIGHT".
The front-end attachments is at the "FRONT". The counterweight is attached at the "REAR".
For the undercarriage, the travel motor is at the "REAR", and the opposite is "FRONT".

1. HOW TO ORDER PARTS

When ordering parts, Please specify the following items as shown in the following example.

(EXAMPLE)		
(1) Model of Machine	(EX120-3)	} Shown on NAME-PLATE provided on MAIN FRAME on the lower right side of CAB
(2) Machine Serial No.	(12V-40001)	
(3) Part No.	(A810165)	} Ordering Parts
(4) Part Name	(O-RING)	
(5) Q'ty	(2)	Ordering Q'ty
(6) Purchaser's Name and Address		

2. HOW TO USE THIS PARTS CATALOG

- ITEM Item No. shows the reference No. on the machine illustration.
- PART NO. Part No. consists of a letter of the alphabet and numerals, or numerals only.
- PART NAME Components of an assembly part are shown with "." marks and are shown on the line, or lines, below the assembly part. Also, if the component with "." mark consists of further components part, these further components are shown by the marks "...".

- Q' TY Q'ty shows the quantity used for a particular single hydraulic unit, however quantity of components shows the quantity for one assembly part.
- SERVICE CODE Abbreviations in the column of service code have their own meaning as shown below.
- W: The part with this abbreviation shows that the part requires some work on it before installing in the machine.
 - D: The part with this abbreviation is a component of an assembly and is not available independently. The assembly part containing this part should be orderd.
 - K: This means that the part is contained in the service parts kit.
 - R: The part with this abbreviation shows that the quantity of the part is changed depending upon the machine, such as an adjusting shim etcetera.
 - S: This part is specially provided as a service part, which was not provided in the machine before from shipping the factory.
 - OP: Optional parts
 - OS: Over-sized parts
 - US: Under-sized parts
- (NOTE: Part with abbreviation "OS" or "US" is described on the line below the standard-sized part.)
- #: The part with this mark is newly added on that page of the equipment.
- SERIAL No. Applicable machine serial No. for the part is shown in this column. Further, above this column, the applicable serial No. is shown for all parts described on that page.
- Take this serial No. if the part is not mentioned its own applicable serial No. Take the serial No. which includes both of for the part and for all parts desclibed on the page if the part is mensioned its own applicable serial No. If the abbreviation "D" is described as headed letter instead of the serial No. it means the producted date of the machine in which the parts are used.
- (EXSAMPLE: D94/01-.....producted on January 1994 and after)
- If the abbreviation "H" is described as headed letter, it means the serial No. of equipment such as PUMP, MOTOR, CONTROL VALVE and etcetera.
- If the abbreviation "F" is described as headed letter, it means the Front No. of front-end attachments such as BUCKET, BOOM, ARM and etcetera.
- ICA ICA shows the interchangeability between the original and the improved parts. Abbreviations used in this column are as follows.
- I: Part No. in the column of "Replaceable part" can be used instead of this part but not vice versa.
 - P: This must not be used for the machine. The part No. in the column "Replaceable part" should be used instead.
 - T: Parts Nos. those in the column of "Replaceable part" can be used as an assembly instead of this part.
 - Y: This part and the part in the column of "Replaceable part" are interchangeable with each other.

·REPLACEABLE PART

Interchangeable parts Nos. and their required quantity are shown in this column.

NOTE: If interchangeable improved parts are provided for the parts which you may order, the improved parts classified as 'I', 'P', 'T' or 'Y' may be supplied.

目 次
CONTENTS

P B - 1 1 3
P B - A 1 6

部品番号 PART NO.	コード CODE	部 品 名	PART NAME	適用号機 SERIAL NO.	頁 PAGE
		ポンプ	P U M P		
9121198	9121198A	ポンプ ; シングル	PUMP;SINGLE		001
++++++	9121200A	・ポンプ ; ユニット	・PUMP;UNIT		003
++++++	9128251A	・ ・ センサ ; アンクル	・ ・ SENSOR;ANGLE		005
4276918	0450900B	・ポンプ ; ギヤ	・PUMP;GEAR		007
		モータ ; オイル	M O T O R ; O I L		
9122946	9122946A	モータ ; オイル (走行)	MOTOR;OIL (TRAVEL)		009
9122945	9122945A	・バルブ ; ブレーキ	・VALVE;BRAKE		011
9120414	9120414A	・ ・バルブ ; リリーフ	・ ・ VALVE;RELIEF		013
4334356	0614700A	モータ ; オイル (旋回)	MOTOR;OIL (SWING)		015
4334357	0614800A	・ロータリグループ	・ROTARY GROUP		017
4286402	0407900A	・シャフト部	・SHAFT PART		019
4327557	0605300A	・カバー部	・COVER PART		021
4328226	0605400A	・ ・バルブ ; リリーフ	・ ・ VALVE;RELIEF		023
		バルブ	V A L V E		
4338612	-----	バルブ ; コントロール	VALVE;CONTROL		---
++++++	0612500	・バルブ ; コントロール (1/8)	・VALVE;CONTROL (1/8)		025
++++++	0612600	・バルブ ; コントロール (2/8)	・VALVE;CONTROL (2/8)		027
++++++	0612700	・バルブ ; コントロール (3/8)	・VALVE;CONTROL (3/8)		029
++++++	0612800	・バルブ ; コントロール (4/8)	・VALVE;CONTROL (4/8)		031
++++++	0612900	・バルブ ; コントロール (5/8)	・VALVE;CONTROL (5/8)		033
++++++	0613000	・バルブ ; コントロール (6/8)	・VALVE;CONTROL (6/8)		035
++++++	0613100	・バルブ ; コントロール (7/8)	・VALVE;CONTROL (7/8)		037
++++++	0613200	・バルブ ; コントロール (8/8)	・VALVE;CONTROL (8/8)		039
9134232	9134232B	バルブ ; パイロット	VALVE;PILOT		041
9101512	9101512B	バルブ ; パイロット	VALVE;PILOT		043
9072923	9072923E	バルブ ; パイロット	VALVE;PILOT		045
4276904	0408400C	バルブ ; ソレノイド	VALVE;SOLENOID		047
4338854	0612400A	バルブ ; フロウコントロール	VALVE;FC.		049
4254613	0408500A	バルブ ; シャトル	VALVE;SHUTTLE		051
4254612	0408600A	バルブ ; シャトル	VALVE;SHUTTLE		053
4254611	0396600B	バルブ ; ロック	VALVE;LOCK		055
4311300	0615800	バルブ ; ホールディング	VALVE;HOLDING	40001-D94/11	057
4345286	0620300	バルブ ; ホールディング	VALVE;HOLDING	D94/12-	059

部品番号 PART NO.	コード CODE	部品名	PART NAME	適用号機 SERIAL NO.	頁 PAGE
4311301	0620400	バルブ ; ホールディング	VALVE;HOLDING		061
4311302	0620500	バルブ ; ホールディング	VALVE;HOLDING		063
4282545	0672700	バルブ ; ロータリ	VALVE;ROTARY		065
4288148	0437400A	バルブ	VALVE		067
シリンダ			CYLINDER		
4257642	0408800A	シリンダ ; ブーム (右)	CYL. ;BOOM (R)		069
4257643	0408900A	シリンダ ; ブーム (左)	CYL. ;BOOM (L)		071
4257644	0409000A	シリンダ ; アーム	CYL. ;ARM		073
4269538	0409100A	シリンダ ; バケツ	CYL. ;BUCKET		075
4288744	0496600A	シリンダ ; クラムシェル	CYL. ;CLAMSHELL		077
その他			ETC.		
9101532	9101532B	センサ ; DP	SENSOR;DP		079
索引			PARTS INDEX		081

001A

ポンプ ; シングル
PUMP ; SINGLE

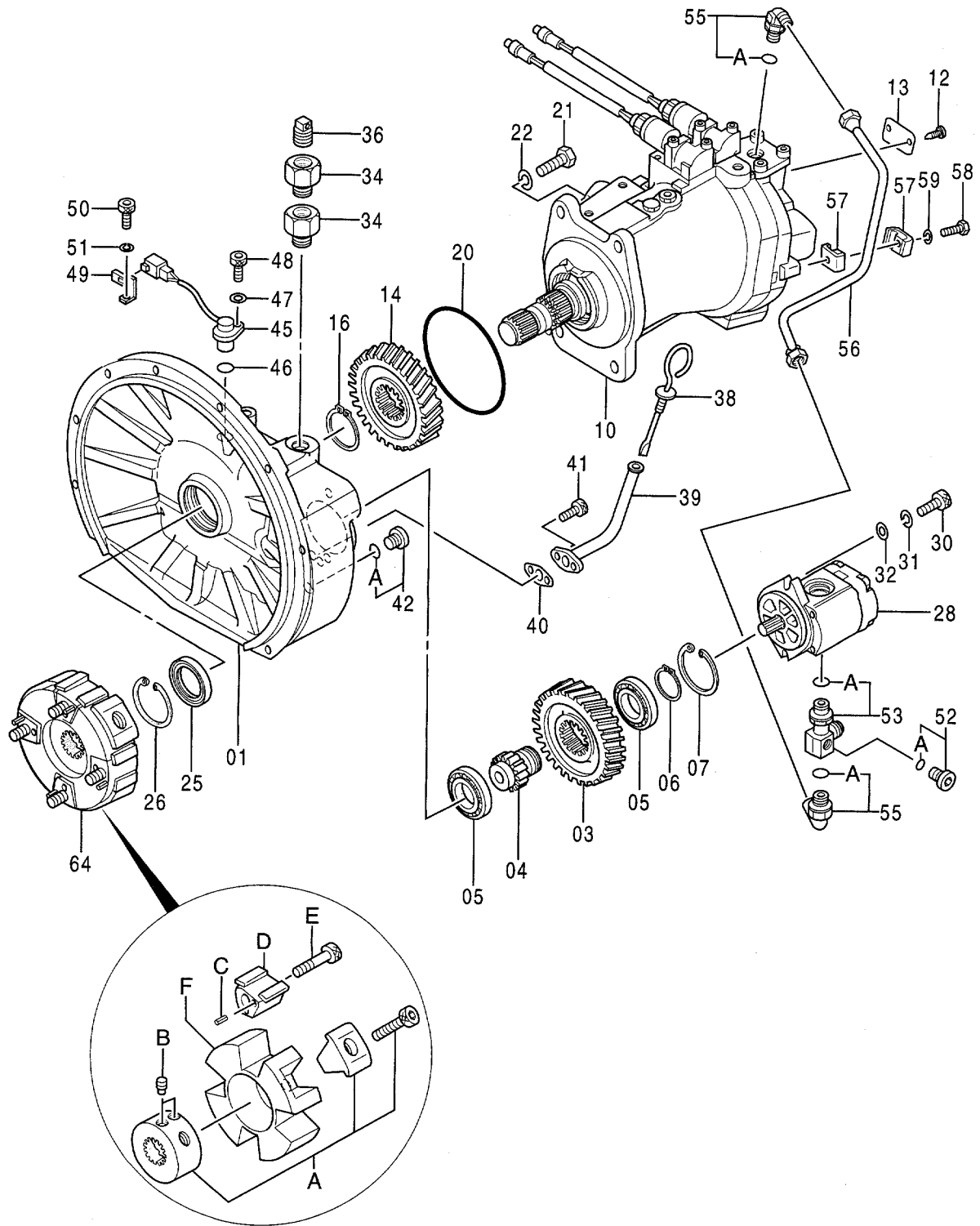

ポンプ ; シングル
PUMP ; SINGLE

40001-

符号 ITEM	部品番号 PART NO.	部品名 PART NAME	コード CODE	数量 Q'TY	サービス コード S.C	適用号機 SERIAL NO.	代替部品 REPLACEABLE PART		
							互換性 ICA	部品番号 PART NO.	数量 Q'TY
	9121198	PUMP;SINGLE <for assembly of machine>	9121198A	1			I	9133005	1
	(9133005)	PUMP;SINGLE <for transportation>		1	S				
01	1018997	・CASING;GEAR		1					
03	3063840	・GEAR;PILOT		1					
04	3055594	・SHAFT;GEAR		1					
05	958740	・BRG.;BALL		2					
06	962002	・RING;RETAINING		1					
07	991725	・RING;RETAINING		1					
10	+++++	・PUMP;UNIT	9121200A	1	D				
12	M492564	・SCREW;DRIVE		2					
13	3069415	・NAME-PLATE		1					
14	3064810	・GEAR;DRIVE		1					
16	4274552	・RING;RETAINING		1					
20	4314092	・O-RING		1					
21	M211645	・BOLT		4					
22	A590916	・WASHER;SPRING		4					
25	4310055	・SEAL;OIL		1					
26	991725	・RING;RETAINING		1					
28	4276918	・PUMP;GEAR	0450900B	1					
30	M341028	・BOLT;SOCKET		2					
31	984054	・WASHER;SPRING		2					
32	4114402	・WASHER		2					
34	4317633	・ADAPTER		2					
36	4234782	・PLUG		1					
38	4242263	・GAUGE;LEVEL		1		-H435	I	4340855	1
38	4340855	・GAUGE;LEVEL		1		H436-			
39	9736788	・PIPE		1					
40	4243160	・PACKING		1					
41	M340816	・BOLT;SOCKET		2					
42	9134111	・PLUG		1					
42A	4509180	・O-RING		1					
45	4265372	・SENSOR;REVOL.		1					
46	4306888	・O-RING		1					
47	A590106	・WASHER;PLANE		1					
48	M340616	・BOLT;SOCKET		1					
49	4252767	・BRACKET		1					
50	M340613	・BOLT;SOCKET		1					
51	4169516	・WASHER;SPRING		1					

001B

ポンプ ; シングル
PUMP ; SINGLE

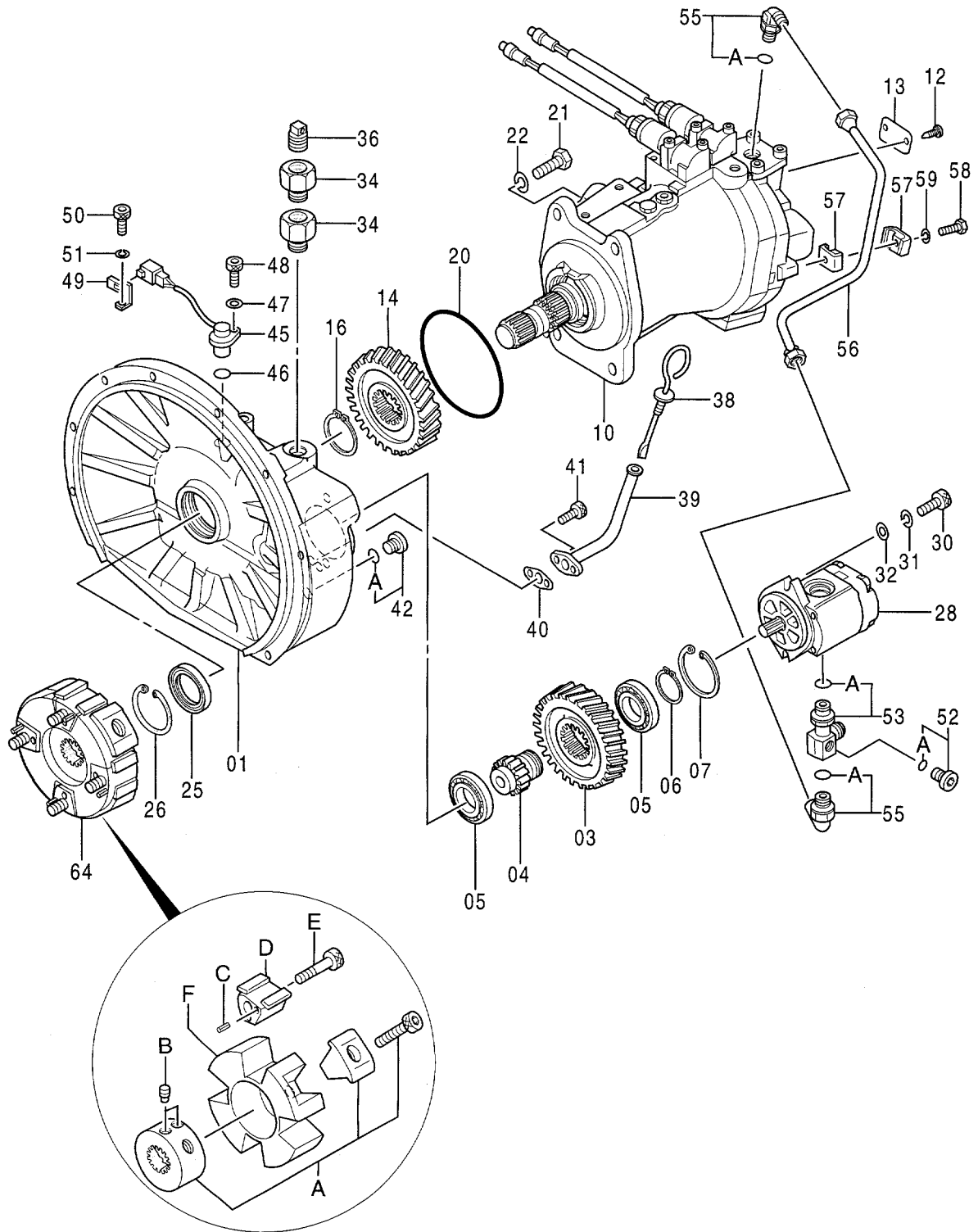

9121198A

Thank you so much for reading.
Please click the “Buy Now!”
button below to download the
complete manual.



After you pay.

You can download the most
perfect and complete manual in
the world immediately.

Our support email:

ebooklibonline@outlook.com