

編 番
PART NO.
PI2V-1-3

PARTS CATALOG

パーツカタログ

EX120-3

Excavator

適用号機 40001~
Serial No.

HITACHI

FOREWORD

- ◎ This parts catalog shows the components of EX120-3 Hydraulic Excavator.
The numerical parts No. index is provided at the end of this parts catalog.
In the parts index, a part No. with '*' mark shows a newly added part on the parts catalog.
- ◎ This parts catalog contains the most recent information available at the time of printing, and the contents of the list are based on information in effect at that time and are subject to change without notice.
- ◎ The references in the parts catalog of "LEFT", "RIGHT", "FRONT" and "REAR" are identified as follows.
The driver's seat is positioned "LEFT" side, and the opposite side is "RIGHT".
The front-end attachments is at the "FRONT". The counterweight is attached at the "REAR".
For the undercarriage, the travel motor is at the "REAR", and the opposite is "FRONT".
- ◎ For the engine parts, please refer to the parts catalog of ISUZU diesel engine 4BD1T issued separately.

1. HOW TO ORDER PARTS

When ordering parts, Please specify the following items as shown in the following example.

	(EXAMPLE)	
(1) Model of Machine	(EX120-3)	} Shown on NAME-PLATE provided on MAIN FRAME on the lower right side of CAB
(2) Machine Serial No.	(12V-40001)	
(3) Part No.	(A810165)	} Ordering Parts
(4) Part Name	(O-RING)	
(5) Q'ty	(2)	Ordering Q'ty
(6) Purchaser's Name and Address		

2. HOW TO USE THIS PARTS CATALOG

- ITEM Item No. shows the reference No. on the machine illustration.
- PART NO. Part No. consists of a letter of the alphabet and numerals, or numerals only.

·PART NAME Components of an assembly part are shown with "." marks and are shown on the line, or lines, below the assembly part. Also, if the component with "." mark consists of further components part, these further components are shown by the marks

·Q' TY Q'ty shows the quantity used for one machine, however quantity of components shows the quantity for one assembly part.

·SERVICE CODE Abbreviations in the column of service code have their own meaning as shown below.

W: The part with this abbreviation shows that the part requires some work on it before installing in the machine.

H: As the part with this abbreviation shows a precision part, please ask the authority for its repairing.

D: The part with this abbreviation is a component of an assembly and is not available independently. The assembly part containing this part should be orderd.

K: This means that the part is contained in the service parts kit.

R: The part with this abbreviation shows that the quantity of the part is changed depending upon the machine, such as an adjusting shim etcetera.

S: This part is specially provided as a service part, which was not provided in the machine before from shipping the factory.

Z: The part with this abbreviation related to the ENGINE.

OP: Optional parts

OS: Over-sized parts

US: Under-sized parts

(NOTE: Part with abbreviation "OS" or "US" is described on the line below the standard-sized part.)

#: The part with this mark is newly added on that page of the equipment.

·SERIAL No. Applicable machine serial No. for the part is shown in this column. Further, above this column, the applicable serial No. is shown for all parts described on that page.

Take this serial No. if the part is not mentioned its own applicable serial No. Take the serial No. which includes both of for the part and for all parts desclibed on the page if the part is mensioned its own applicable serial No. If the abbreviation "D" is described as headed letter instead of the serial No. it means the producted date of the machine in which the parts are used. (EXSAMPLE: D94/01-.....producted on January 1994 and after)

If the abbreviation "H" is described as headed letter, it means the serial No. of equipment such as PUMP, MOTOR, CONTROL VALVE and etcetera.

If the abbreviation "F" is described as headed letter, it means the Front No. of front-end attachments such as BUCKET, BOOM, ARM and etcetera.

·ICA

ICA shows the interchangeability between the original and the improved parts. Abbreviations used in this column are as follows.

- I: Part No. in the column of "Replaceable part" can be used instead of this part but not vice versa.
- P: This must not be used for the machine. The part No. in the column "Replaceable part" should be used instead.
- T: Parts Nos. those in the column of "Replaceable part" can be used as an assembly instead of this part.
- Y: This part and the part in the column of "Replaceable part" are interchangeable with each other.

·REPLACEABLE PART

Interchangeable parts Nos. and their required quantity are shown in this column.

NOTE: If interchangeable improved parts are provided for the parts which you may order, the improved parts classified as "I", "P", "T" or "Y" may be supplied.

目次 CONTENTS



上部旋回体
UPPERSTRUCTURE

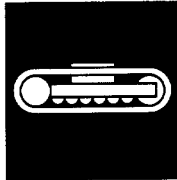

下部走行体
UNDERCARRIAGE



フロントアタッチメント
FRONT-END ATTACHMENTS

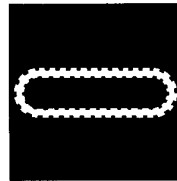

ゴムクローラ関係部品
RUBBER CRAWLER PARTS



オプションパーツ
OPTIONAL PARTS

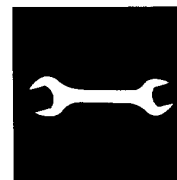

工具および予備品
TOOLS AND SPARE PARTS



ネームプレート
NAME-PLATE

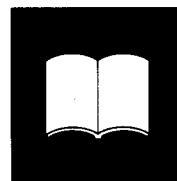

索引
PARTS INDEX

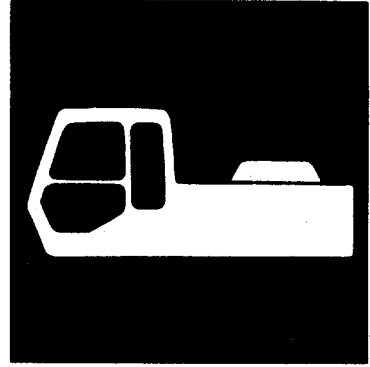

上 部 旋 回 体
UPPERSTRUCTURE

フレーム FRAME

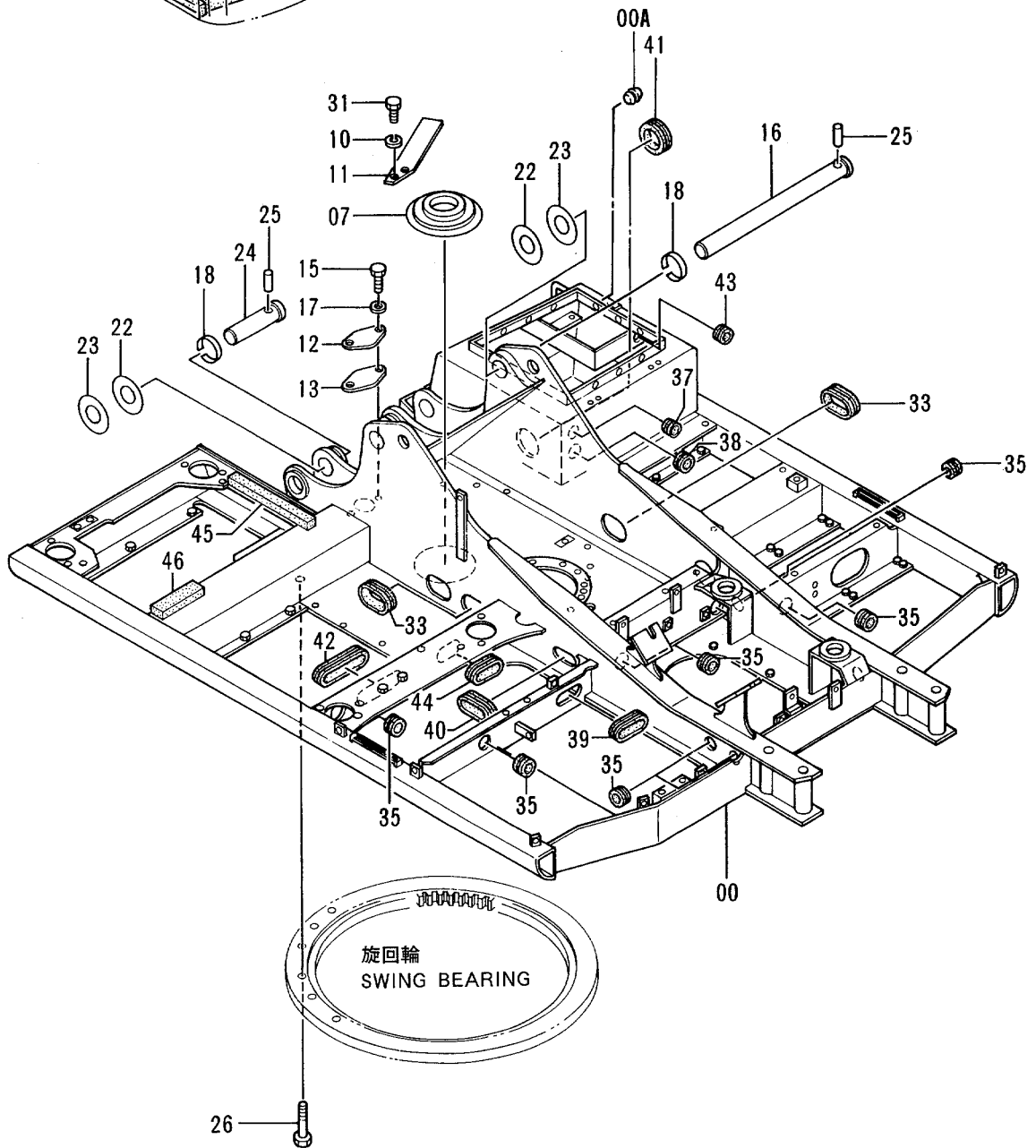
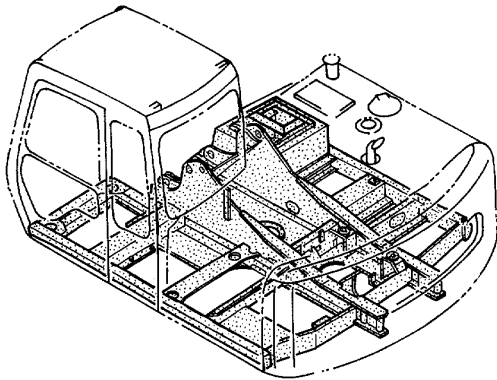

フレーム
FRAME

40001-

符号 ITEM	部品番号 PART NO.	部品名	PART NAME	数量 QTY	サービス コード S.C	適用号機 SERIAL NO.	互換性 ICA	代替部品 REPLACEABLE PART	
								部品番号 PART NO.	数量 QTY
00	5004373	フレーム;メイン	FRAME;MAIN	1					
00A	4306949	・プラグ	・PLUG	12					
07	4258592	カバー;ブーツ	COVER;BOOT	1					
10	A590914	ワッシャ;スプリング	WASHER;SPRING	2					
11	3057962	ストッパ	STOPPER	1					
12	4255799	カバー	COVER	1					
13	4161735	パッキン	PACKING	1					
15	J901025	ボルト	BOLT	2					
16	3050671	ピン	PIN	1					
17	A590110	ワッシャ;プレーン	WASHER;PLANE	2					
18	4098716	リング	RING	3					
22	4252331	シム 1.0	SHIM 1.0	4	R				
23	4252332	シム 2.0	SHIM 2.0	4	R				
24	3051616	ピン	PIN	2					
25	4106307	ピン	PIN	3					
26	J931890	ボルト	BOLT	28					
31	J901435	ボルト	BOLT	2					
33	4201750	ブッシング;ラバー	BUSHING;RUBBER	2					
35	4509404	ブッシング;ラバー	BUSHING;RUBBER	8					
37	4198176	ブッシング;ラバー	BUSHING;RUBBER	1					
38	94-2816	ブッシング;ラバー	BUSHING;RUBBER	1					
39	4264106	ブッシング;ラバー	BUSHING;RUBBER	1					
40	4276062	ブッシング;ラバー	BUSHING;RUBBER	1					
41	4093813	ブッシング;ラバー	BUSHING;RUBBER	1					
42	4202008	ブッシング;ラバー	BUSHING;RUBBER	1					
43	94-2806	ブッシング;ラバー	BUSHING;RUBBER	1					
44	4264106	ブッシング;ラバー	BUSHING;RUBBER	1		-40010			
44	4339947	ブッシング;ラバー	BUSHING;RUBBER	1		40011-			
45	4340406	ラバー	RUBBER	1					
46	4340407	ラバー	RUBBER	1					

003

カウンタウェイト
COUNTERWEIGHT

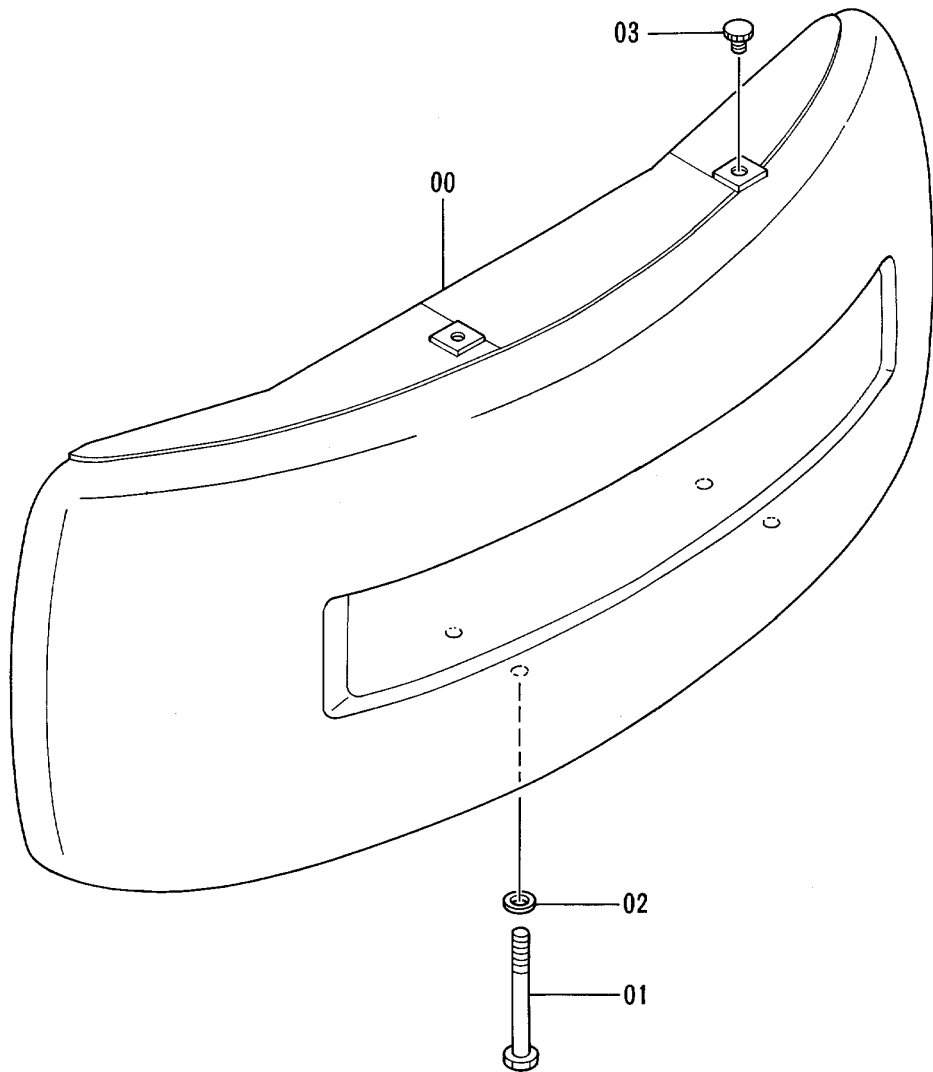
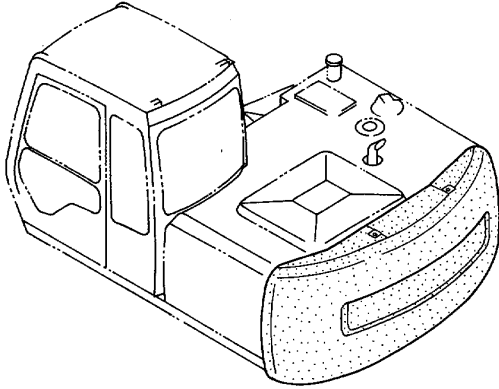

カウンタイト
COUNTERWEIGHT

40001-

符号 ITEM	部品番号 PART NO.	部 品 名	PART NAME	数量 Q'TY	サービス コード S.C	適用号機 SERIAL NO.	互 換 性 ICA	代替部品 REPLACEABLE PART	
								部品番号 PART NO.	数量 Q'TY
00	5003233	ウイト;カウンタ	WEIGHT;COUNTER	1					
01	J932720	ボルト	BOLT	4					
02	4126485	ワッシャ	WASHER	4					
03	4149678	キャップ	CAP	2					

エンジン ENGINE

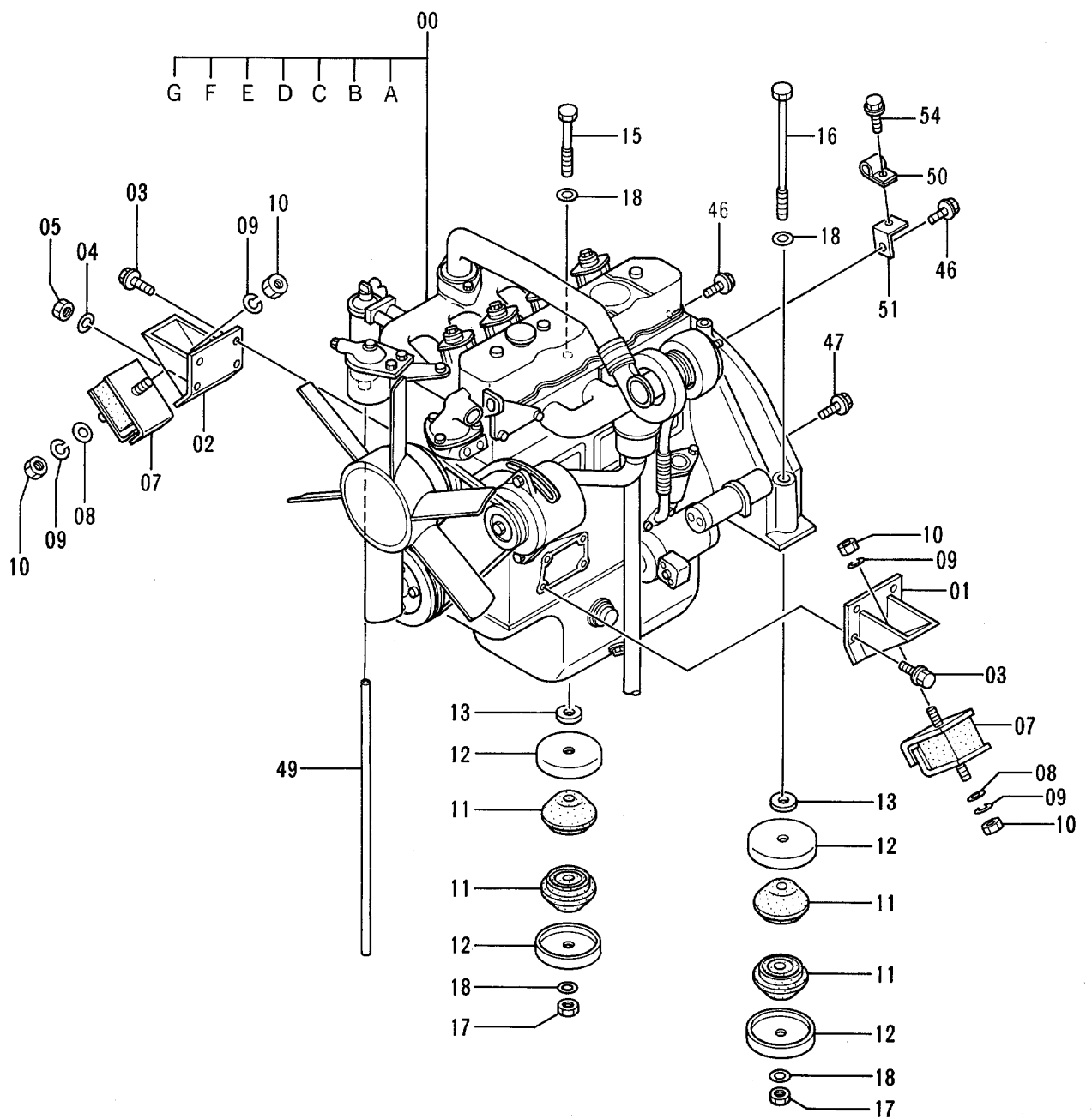
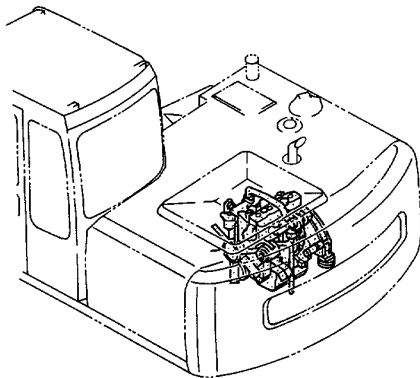

エンジン
ENGINE

40001-

符号 ITEM	部品番号 PART NO.	部 品 名	PART NAME	数量 QTY	サービス コード S.C	適用号機 SERIAL NO.	互 換 性 ICA	代 替 部 品 REPLACEABLE PART	
								部品番号 PART NO.	数量 QTY
00	4332140	エンジン	ENGINE	1	Z				
00A	4179863	・ベルト;V	・BELT;V	1	Z				
00B	4183853	・フィルタ;オイル (メイン)	・FILTER;OIL (MAIN)	1	Z				
00C	4285642	・フィルタ;オイル (バイパス)	・FILTER;OIL (BYPASS)	1	Z				
00D	4285643	・フィルタ;フューエル	・FILTER;FUEL	1	Z				
00E	4164695	・スイッチ;レベル (オイルレベルセンサ)	・SWITCH;LEVEL (OIL LEVEL SENSOR)	1	Z				
00F	4201132	・スイッチ;プレッシャ	・SWITCH;PRESSURE	1	Z				
00G	4223444	・スイッチ;サーモ (オーバーヒートワーニング)	・SWITCH;THERMOMETER (OVER HEAT WARNING)	1	Z				
01	8021976	ブラケット	BRACKET	1					
02	8021977	ブラケット	BRACKET	1					
03	M171022	ボルト;セムス	BOLT;SEMS	7					
04	A590910	ワッシャ;スプリング	WASHER;SPRING	1					
05	J952010	ナット	NUT	1					
07	4255652	ラバー	RUBBER	2					
08	4086894	ワッシャ	WASHER	2					
09	A590914	ワッシャ;スプリング	WASHER;SPRING	4					
10	J950014	ナット	NUT	4					
11	4177883	ラバー	RUBBER	4					
12	4169423	ストッパ	STOPPER	4					
13	4185675	ストッパ	STOPPER	2					
15	J931613	ボルト	BOLT	1					
16	4176282	ボルト	BOLT	1					
17	J951016	ナット	NUT	2					
18	J222016	ワッシャ	WASHER	4					
46	J011035	ボルト;セムス	BOLT;SEMS	4					
47	J011030	ボルト;セムス	BOLT;SEMS	3					
49	4171509	ホース;ビニール	HOSE;VINYL	1					
50	4190271	クリップ	CLIP	1					
51	9737871	ブラケット	BRACKET	1					
54	J021020	ボルト;セムス	BOLT;SEMS	1					

ラジエータ RADIATOR

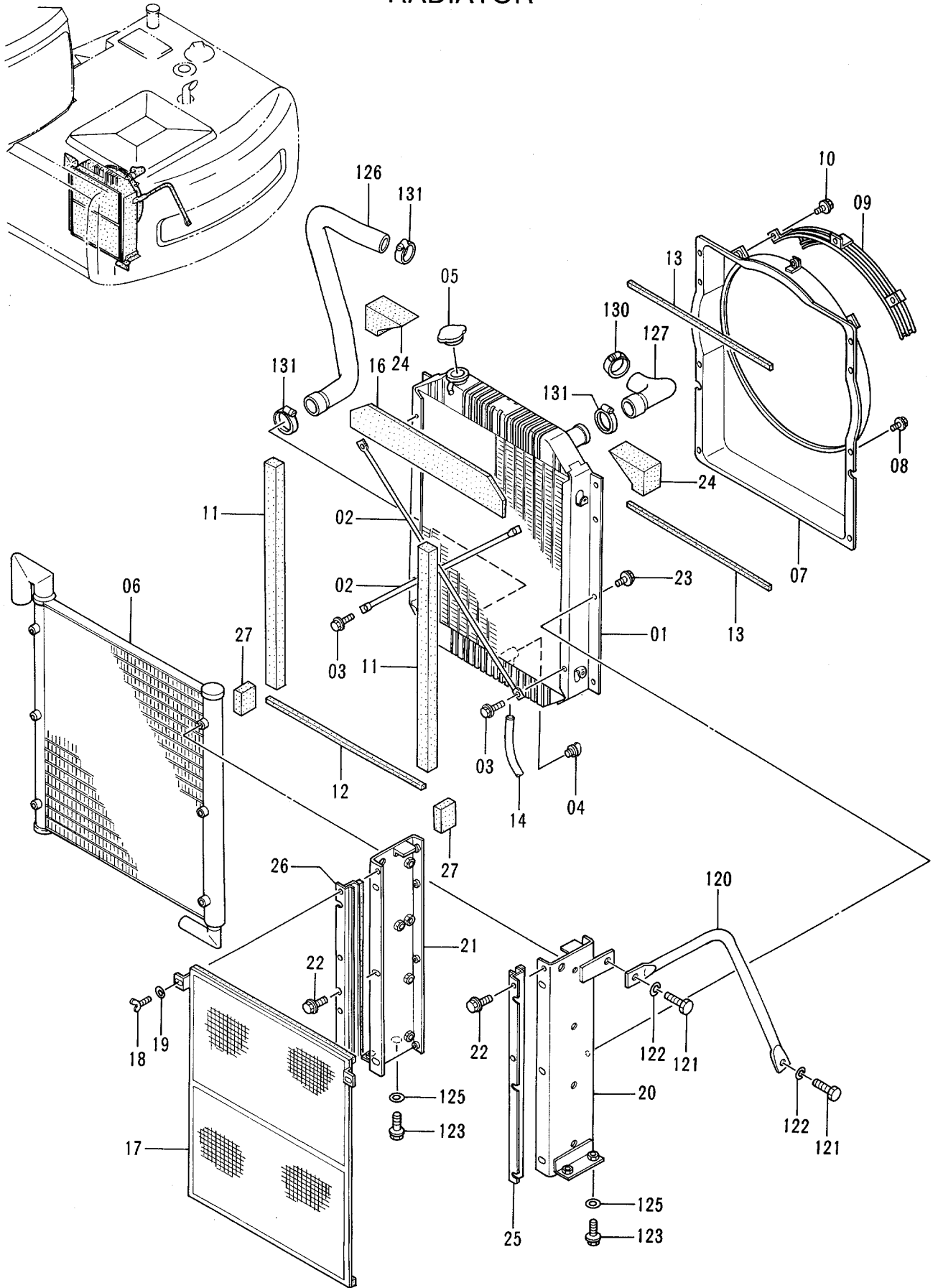

ラジエータ
RADIATOR

40001-

符号 ITEM	部品番号 PART NO.	部 品 名	PART NAME	数量 QTY	サービス コード S.C	適用号機 SERIAL NO.	互 換 性 ICA	代 替 部 品 REPLACEABLE PART	
								部品番号 PART NO.	数量 QTY
01-27	4274494	ラジエータ アッセン	RADIATOR ASS'Y	1					
01	4285626	・コア;ラジエータ	・CORE;RADIATOR	1					
02	4206676	・ロッド	・ROD	2					
03	4206679	・ボルト;セムス	・BOLT;SEMS	4					
04	4206928	・プラグ;ドレン	・PLUG;DRAIN	1					
05	4228160	・キャップ	・CAP	1					
06	4285627	・クーラ;オイル	・COOLER;OIL	1					
07	4228295	・ガイド;ファン	・GUIDE;FAN	1					
08	4285639	・ボルト;セムス	・BOLT;SEMS	8					
09	4204469	・ガード;ファン	・GUARD;FAN	1					
10	4206128	・ボルト;セムス	・BOLT;SEMS	3					
11	4285637	・パッキン	・PACKING	2					
12	4285635	・パッキン	・PACKING	1					
13	4285636	・パッキン	・PACKING	2					
14	4285641	・ホース	・HOSE	1					
16	4285633	・パッキン	・PACKING	1					
17	4285628	・ネット	・NET	1					
18	4206930	・ボルト;ウイング	・BOLT;WING	2					
19	4206931	・ワッシャ	・WASHER	2					
20	4296417	・ブラケット	・BRACKET	1					
21	4296418	・ブラケット	・BRACKET	1					
22	4285640	・ボルト;セムス	・BOLT;SEMS	6					
23	4285640	・ボルト;セムス	・BOLT;SEMS	8					
24	4285634	・パッキン	・PACKING	2					
25	4296419	・ブラケット	・BRACKET	1					
26	4296420	・ブラケット	・BRACKET	1					
27	4285638	・パッキン	・PACKING	2					
120	3052439	ステー	STAY	1					
121	J901635	ボルト	BOLT	2					
122	A590916	ワッシャ;スプリング	WASHER;SPRING	2					
123	J011230	ボルト;セムス	BOLT;SEMS	4					
125	J222012	ワッシャ	WASHER	4					
126	3055716	ホース;ウォーター	HOSE;WATER	1					
127	3050673	ホース;ウォーター	HOSE;WATER	1					
130	4505385	クランプ;ホース	CLAMP;HOSE	1					
131	4504198	クランプ;ホース	CLAMP;HOSE	3					

リザーブタンク RESERVE TANK

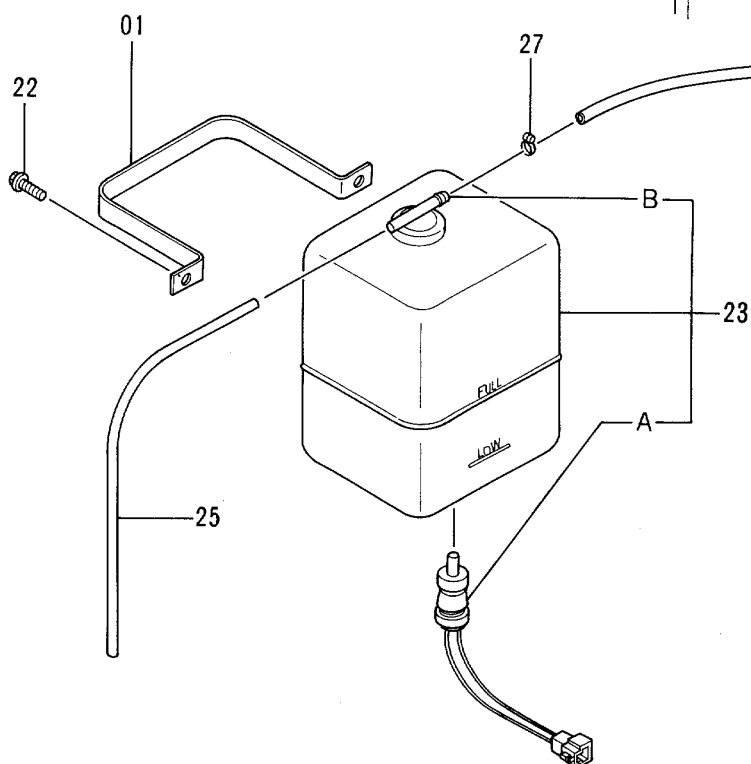
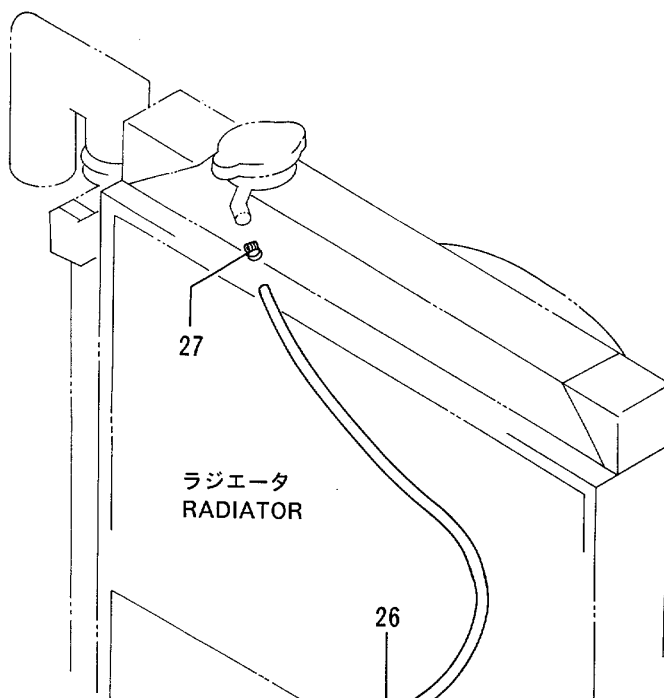
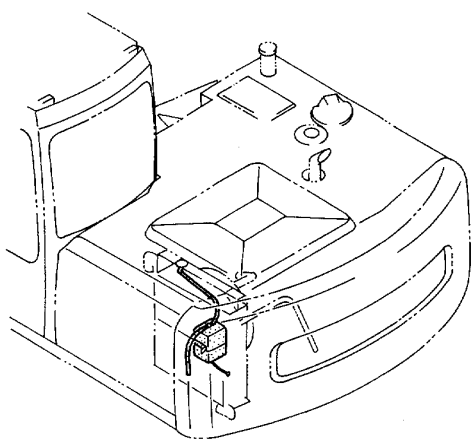

リザーブ タンク
RESERVE TANK

40001-

符号 ITEM	部品番号 PART NO.	部品名	PART NAME	数量 QTY	サービス コード S.C	適用号機 SERIAL NO.	互 換 性 ICA	代替部品 REPLACEABLE PART	
								部品番号 PART NO.	数量 QTY
01	4180555	クランプ	CLAMP	1					
22	J020820	ボルト;セムス	BOLT;SEMS	2					
23	4130139	タンク;ウォーター	TANK;WATER	1					
23A	4153251	-スイッチ;レベル	-SWITCH;LEVEL	1					
23B	4153250	-キャップ	-CAP	1					
25	4142844	ホース;ビニール	HOSE;VINYL	1					
26	4276493	ホース;ウォーター	HOSE;WATER	1					
27	4508575	クランプ;ホース	CLAMP;HOSE	2					

エアクリーナ AIR CLEANER

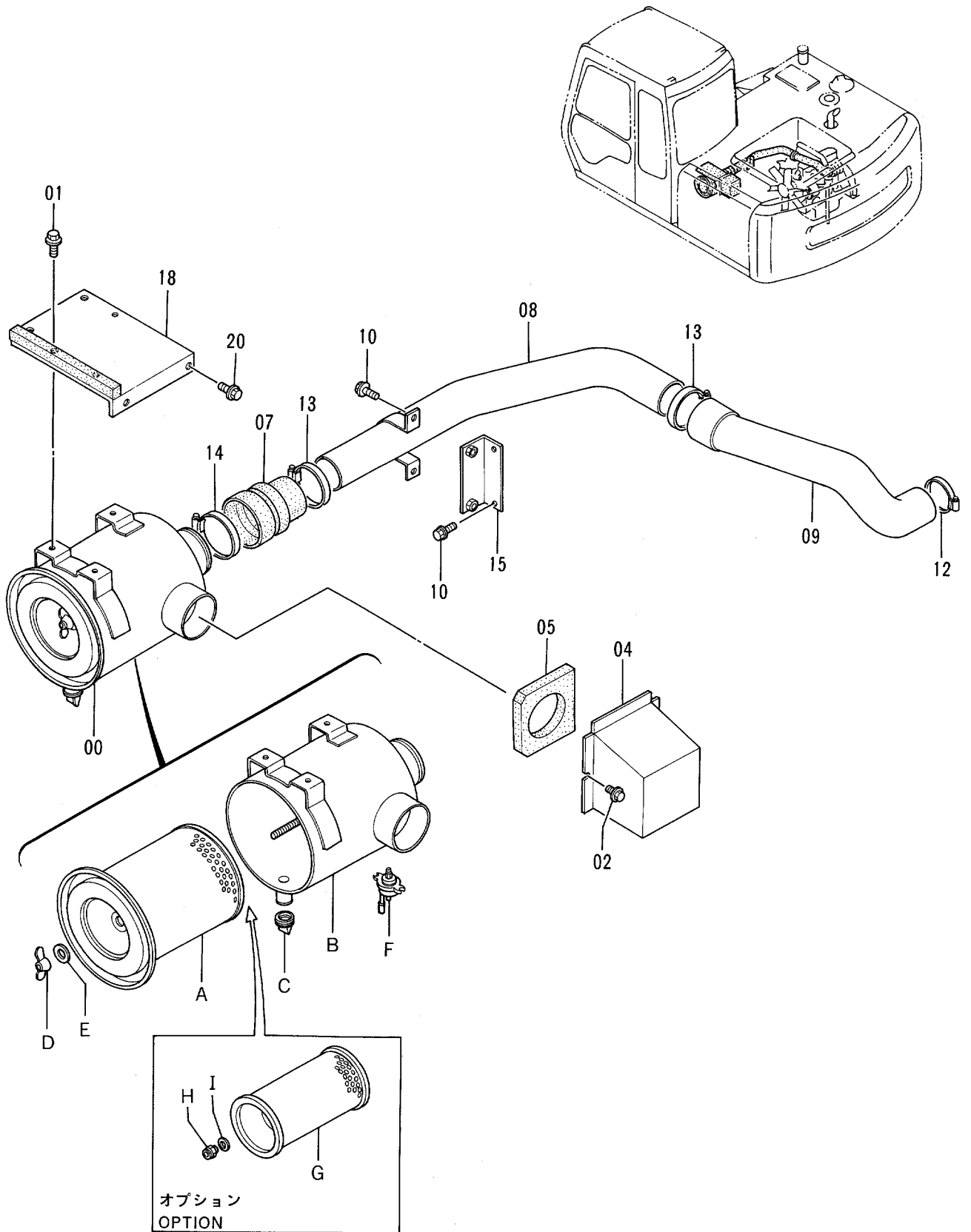

Thank you so much for reading.
Please click the “Buy Now!”
button below to download the
complete manual.



After you pay.

You can download the most
perfect and complete manual in
the world immediately.

Our support email:

ebooklibonline@outlook.com