

編 番
PART NO.
P14C-1-4

PARTS CATALOG

パーツカタログ

EX200-3

EX200LC-3

EX200H-3

EX200LCH-3

Excavator

適用号機 78001~
Serial No.

HITACHI

FOREWORD

- © This parts catalog shows the components of EX200-3, EX200LC-3, EX200H-3 and EX200LCH-3 Hydraulic Excavator.

If a page where the parts of those machines are shown, the following indication is described on the top of the page.

<EXAMPLE>

INDICATION	APPLICABLE MODEL
.....(STD. TRACK)	EX200-3, EX200H-3
.....(LC TRACK)	EX200LC-3, EX200LCH-3
.....<200, LC>	EX200-3, EX200LC-3
.....<200H, LCH>	EX200H-3, EX200LCH-3

The numerical parts No. index is provided at the end of this parts catalog.

In the parts index, a part No. with "*" mark shows a newly added part on the parts catalog.

- © This parts catalog includes parts information for both standard and regional specification models.

Please refer to the identification note given in < > after the Group Name, or Part Name to distinguish between standard and regional parts information as shown below:

Group Name (or Part Name) plus <STD> : for Standard Specification Model

Group Name (or Part Name) plus <USA> : for Northern American Specification models,
delivered to the United States and Canada

Group Name (or Part Name) plus no note : Applicable to all models

Example:

RADIO <USA>----This part is for machines delivered to the United State and Canada.

- © This parts catalog contains the most recent information available at the time of printing, and the contents of the list are based on information in effect at that time and are subject to change without notice.

- © The references in the parts catalog of "LEFT", "RIGHT", "FRONT" and "REAR" are identified as follows.

The driver's seat is positioned "LEFT" side, and the opposite side is "RIGHT".

The front-end attachments is at the "FRONT". The counterweight is attached at the "REAR".

For the undercarriage, the travel motor is at the "REAR", and the opposite is "FRONT".

- © For the engine parts, please refer to the parts catalog of ISUZU diesel engine 6BD1T issued separately.

1. HOW TO ORDER PARTS

When ordering parts, Please specify the following items as shown in the following example.

	(EXAMPLE)	
(1) Model of Machine	(EX200-3)	} Shown on NAME-PLATE provided on MAIN FRAME on the lower right side of CAB
(2) Machine Serial No.	(14C-78001)	
(3) Part No.	(A810165)	} Ordering Parts
(4) Part Name	(O-RING)	
(5) Q'ty	(2)	Ordering Q'ty
(6) Purchaser's Name and Address		

2. HOW TO USE THIS PARTS CATALOG

- ITEM** Item No. shows the reference No. on the machine illustration.
- PART NO.** Part No. consists of a letter of the alphabet and numerals, or numerals only.
- PART NAME** Components of an assembly part are shown with "." marks and are shown on the line, or lines, below the assembly part. Also, if the component with "." mark consists of further components part, these further components are shown by the marks "...".
- Q'TY** Q'ty shows the quantity used for one machine, however quantity of components shows the quantity for one assembly part.
- SERVICE CODE** Abbreviations in the column of service code have their own meaning as shown below.
- W: The part with this abbreviation shows that the part requires some work on it before installing in the machine.
 - H: As the part with this abbreviation shows a precision part, please ask the authority for its repairing.
 - D: The part with this abbreviation is a component of an assembly and is not available independently. The assembly part containing this part should be orderd.
 - K: This means that the part is contained in the service parts kit.
 - R: The part with this abbreviation shows that the quantity of the part is changed depending upon the machine, such as an adjusting shim etcetera.
 - S: This part is specially provided as a service part, which was not provided in the machine before from shipping the factory.
 - Z: The part with this abbreviation related to the ENGINE.
- OP: Optional parts
OS: Over-sized parts
US: Under-sized parts
- (NOTE: Part with abbreviation "OS" or "US" is described on the line below the standard-sized part.)
- #: The part with this mark is newly added on that page of the equipment.

·SERIAL No.

Applicable machine serial No. for the part is shown in this column.

Further, above this column, the applicable serial No. is shown for all parts described on that page.

Take this serial No. if the part is not mentioned its own applicable serial No.

Take the serial No. which includes both of for the part and for all parts described on the page if the part is mentioned its own applicable serial No.

If the abbreviation "D" is described as headed letter instead of the serial No. it means the produced date of the machine in which the parts are used.

(EXAMPLE: D94/01-.....produced on January 1994 and after)

If the abbreviation "H" is described as headed letter, it means the serial No. of equipment such as PUMP, MOTOR, CONTROL VALVE and etcetera.

If the abbreviation "F" is described as headed letter, it means the Front No. of front-end attachments such as BUCKET, BOOM, ARM and etcetera.

·ICA

ICA shows the interchangeability between the original and the improved parts.

Abbreviations used in this column are as follows.

- I: Part No. in the column of "Replaceable part" can be used instead of this part but not vice versa.
- P: This must not be used for the machine. The part No. in the column "Replaceable part" should be used instead.
- T: Parts Nos. those in the column of "Replaceable part" can be used as an assembly instead of this part.
- Y: This part and the part in the column of "Replaceable part" are interchangeable with each other.

·REPLACEABLE PART

Interchangeable parts Nos. and their required quantity are shown in this column.

NOTE: If interchangeable improved parts are provided for the parts which you may order, the improved parts classified as "I", "P", "T" or "Y" may be supplied.

目 次
CONTENTS



上 部 旋 回 体
UPPERSTRUCTURE



下 部 走 行 体
UNDERCARRIAGE



フ ロ ン ト ア タ ッ チ メ ン ト
FRONT-END ATTACHMENTS



ス ー パ ー ロ ン グ フ ロ ン ト
RIVER MAINTENANCE FRONT

OP

オ プ シ ョ ナ ル パ ー ツ
OPTIONAL PARTS



工 具 及 び 予 備 品
TOOLS AND SPARE PARTS

NAME
PLATE

ネ ー ム プ レ ー ト
NAME-PLATE



索 引
PARTS INDEX

目 次

CONTENTS

索 引
PARTS INDEX



索引 421
PARTS INDEX

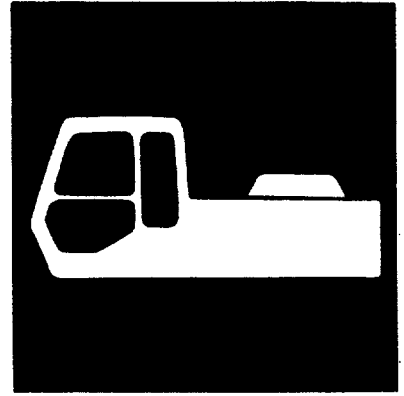

上部旋回体
UPPERSTRUCTURE

フレーム FRAME

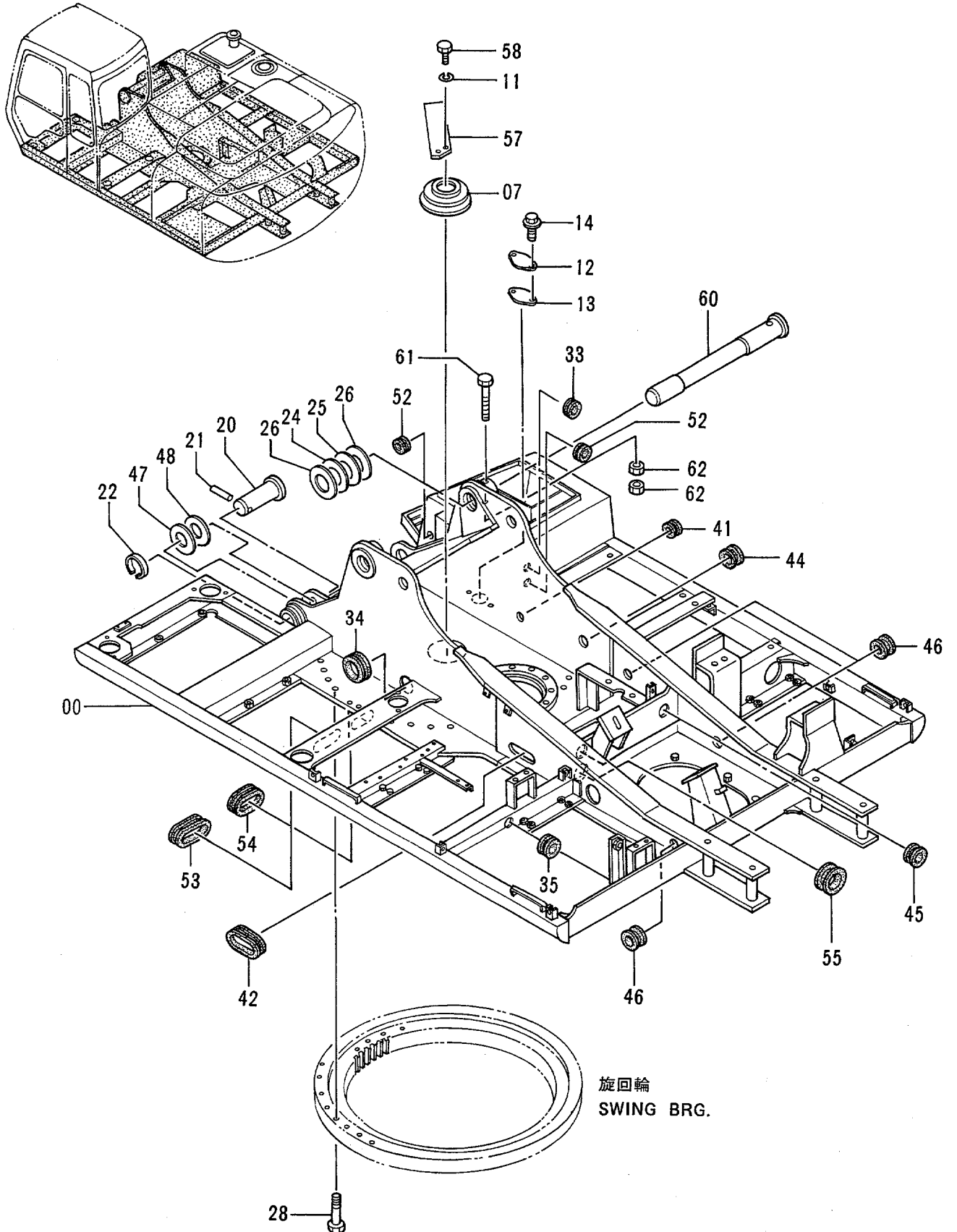

フレーム
FRAME

78001-

符号 ITEM	部品番号 PART NO.	部 品 名	PART NAME	数量 QTY	サービス コード S.C	適用号機 SERIAL NO.	互 換 性 ICA	代 替 部 品 REPLACEABLE PART	
								部品番号 PART NO.	数量 QTY
00	5004161	フレーム;メイン <200, LC>	FRAME;MAIN <200, LC>	1					
00	5004262	フレーム;メイン <200H, LCH>	FRAME;MAIN <200H, LCH>	1					
07	4258592	カバー;ブーツ	COVER;BOOT	1					
11	A590914	ワッシャー;スプリング	WASHER;SPRING	2					
12	4255799	カバー	COVER	1					
13	4161735	パッキング	PACKING	1					
14	J021025	ボルト;セムス	BOLT;SEMS	2					
20	4196104	ピン	PIN	2					
21	4098713	ピン	PIN	2					
22	4098712	リング	RING	2					
24	4101280	シム 3.2	SHIM 3.2	1	R				
25	4142950	シム 2.3	SHIM 2.3	1	R				
26	4101281	シム 1.2	SHIM 1.2	2	R				
28	J932095	ボルト	BOLT	29					
33	94-2816	ブッシング;ラバー	BUSHING;RUBBER	1					
34	4191977	ブッシング;ラバー	BUSHING;RUBBER	1					
35	4209294	ブッシング;ラバー	BUSHING;RUBBER	1					
41	4257181	ブッシング;ラバー	BUSHING;RUBBER	1					
42	4252218	ブッシング;ラバー	BUSHING;RUBBER	1					
44	4259340	ブッシング;ラバー	BUSHING;RUBBER	1					
45	4255530	ブッシング;ラバー	BUSHING;RUBBER	2					
46	4201749	ブッシング;ラバー	BUSHING;RUBBER	3					
47	4114816	シム 2.3	SHIM 2.3	2	R				
48	4114817	シム 1.0	SHIM 1.0	2	R				
52	4276215	ブッシング;ラバー	BUSHING;RUBBER	2					
53	4319252	ブッシング;ラバー	BUSHING;RUBBER	1					
54	4319253	ブッシング;ラバー	BUSHING;RUBBER	1					
55	4201986	ブッシング;ラバー	BUSHING;RUBBER	1					
57	4274282	ストッパ	STOPPER	1					
58	J901435	ボルト	BOLT	2					
60	3058025	ピン	PIN	1					
61	M222004	ボルト	BOLT	1					
62	J951020	ナット	NUT	2					

003

カウンタウェイト
COUNTERWEIGHT

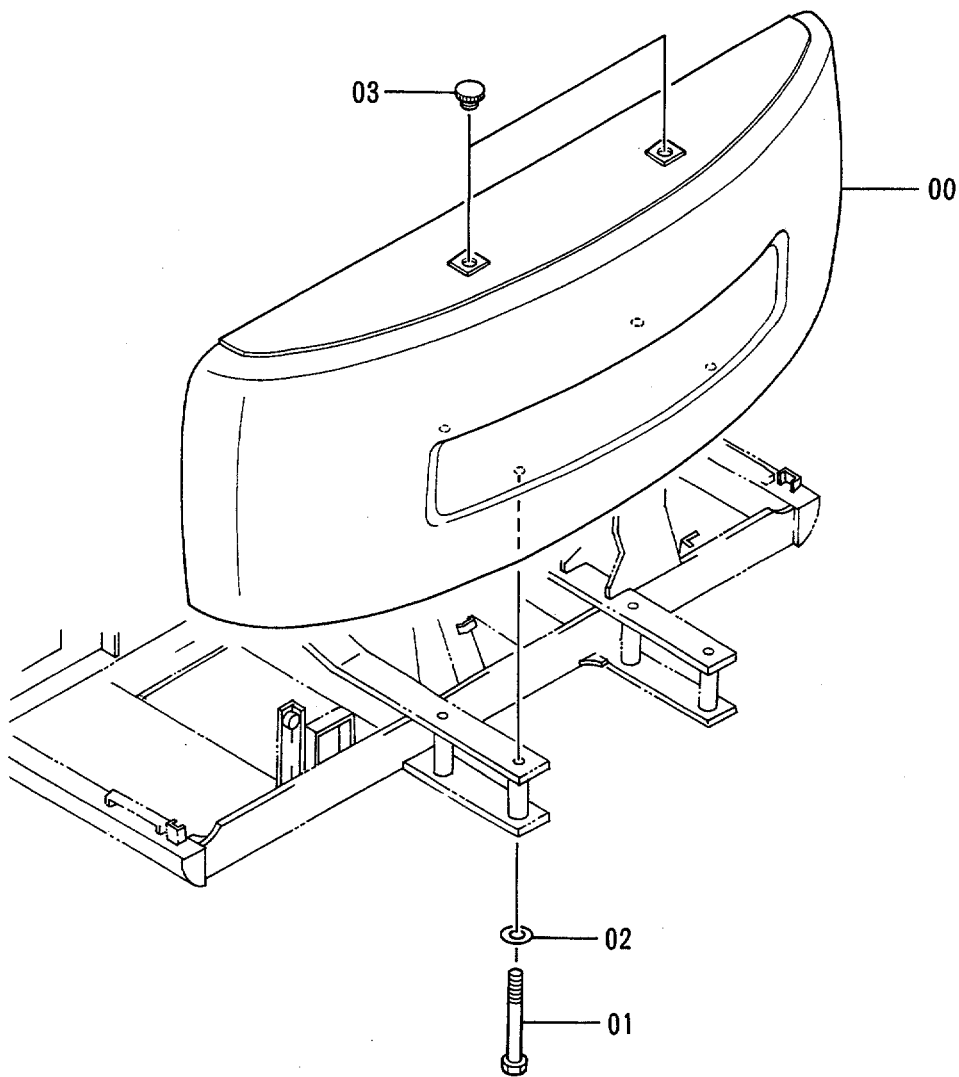
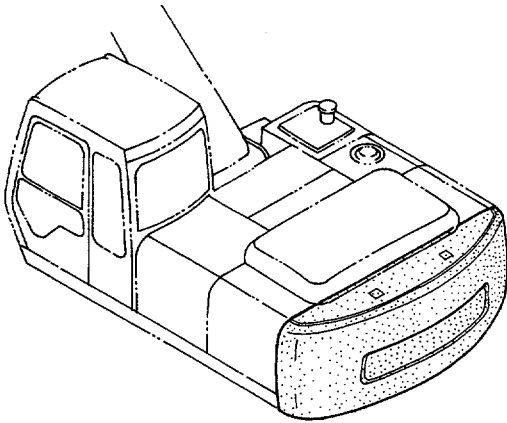

エンジン ENGINE

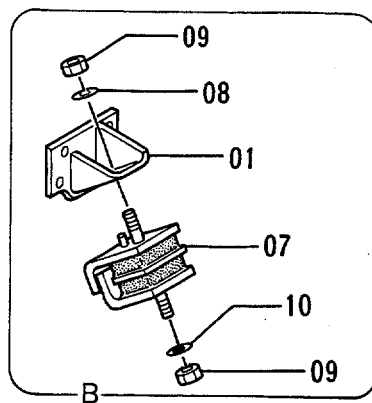
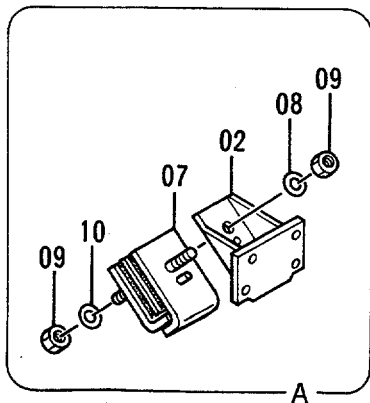
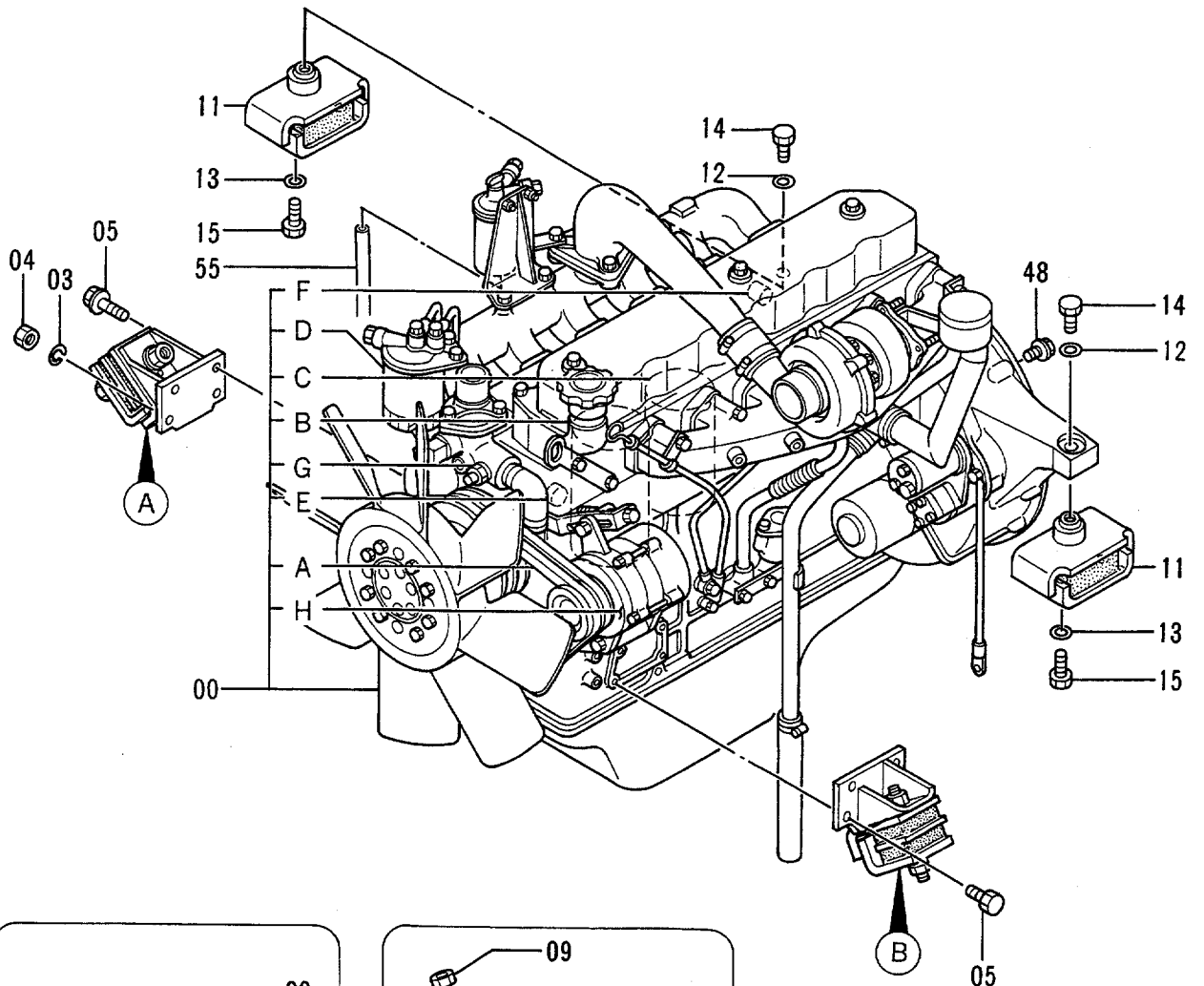
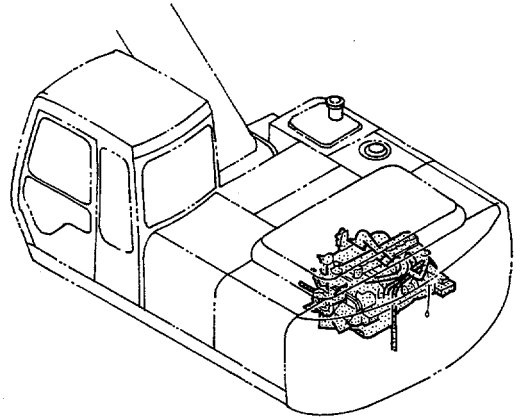

エンジン
ENGINE

78001-

符号 ITEM	部品番号 PART NO.	部品名	PART NAME	数量 QTY	サービス コード S.C	適用号機 SERIAL NO.	互換性 ICA	代替部品 REPLACEABLE PART	
								部品番号 PART NO.	数量 QTY
00	4248359	エンジン	ENGINE	1	Z				
00A	4206078	・ベルト;ファン (1=2本)	・BELT;FAN (1=2 PIECES)	1	Z				
00B	4283859	・フィルタ;オイル (メイン)	・FILTER;OIL (MAIN)	1	Z				
00C	4283860	・フィルタ;オイル (バイパス)	・FILTER;OIL (BYPASS)	1	Z				
00D	4206080	・フィルタ;フューエル	・FILTER;FUEL	1	Z				
00E	4164695	・スイッチ;レベル	・SWITCH;LEVEL	1	Z				
00F	4201132	・スイッチ;プレッシャ	・SWITCH;PRES.	1	Z				
00G	4149335	・スイッチ;サーモ	・SWITCH;THERMO	1	Z				
00H	4283858	・ジェネレータ	・GENERATOR	1	Z				
01	8021976	ブラケット	BRACKET	1					
02	8021977	ブラケット	BRACKET	1					
03	A590910	ワッシャ;スプリング	WASHER;SPRING	1					
04	J952010	ナット	NUT	1					
05	M171022	ボルト;セムス	BOLT;SEMS	7					
07	4123994	ラバー	RUBBER	2					
08	4114404	ワッシャ	WASHER	2					
09	J950014	ナット	NUT	4					
10	4086894	ワッシャ	WASHER	2					
11	4248362	ラバー	RUBBER	2					
12	A590918	ワッシャ;スプリング	WASHER;SPRING	2					
13	4087197	ワッシャ	WASHER	4					
14	J931865	ボルト	BOLT	2					
15	J931630	ボルト	BOLT	4					
48	J011030	ボルト;セムス	BOLT;SEMS	5					
55	4206284	ホース;ビニール	HOSE;VINYL	1					

ラジエータ RADIATOR

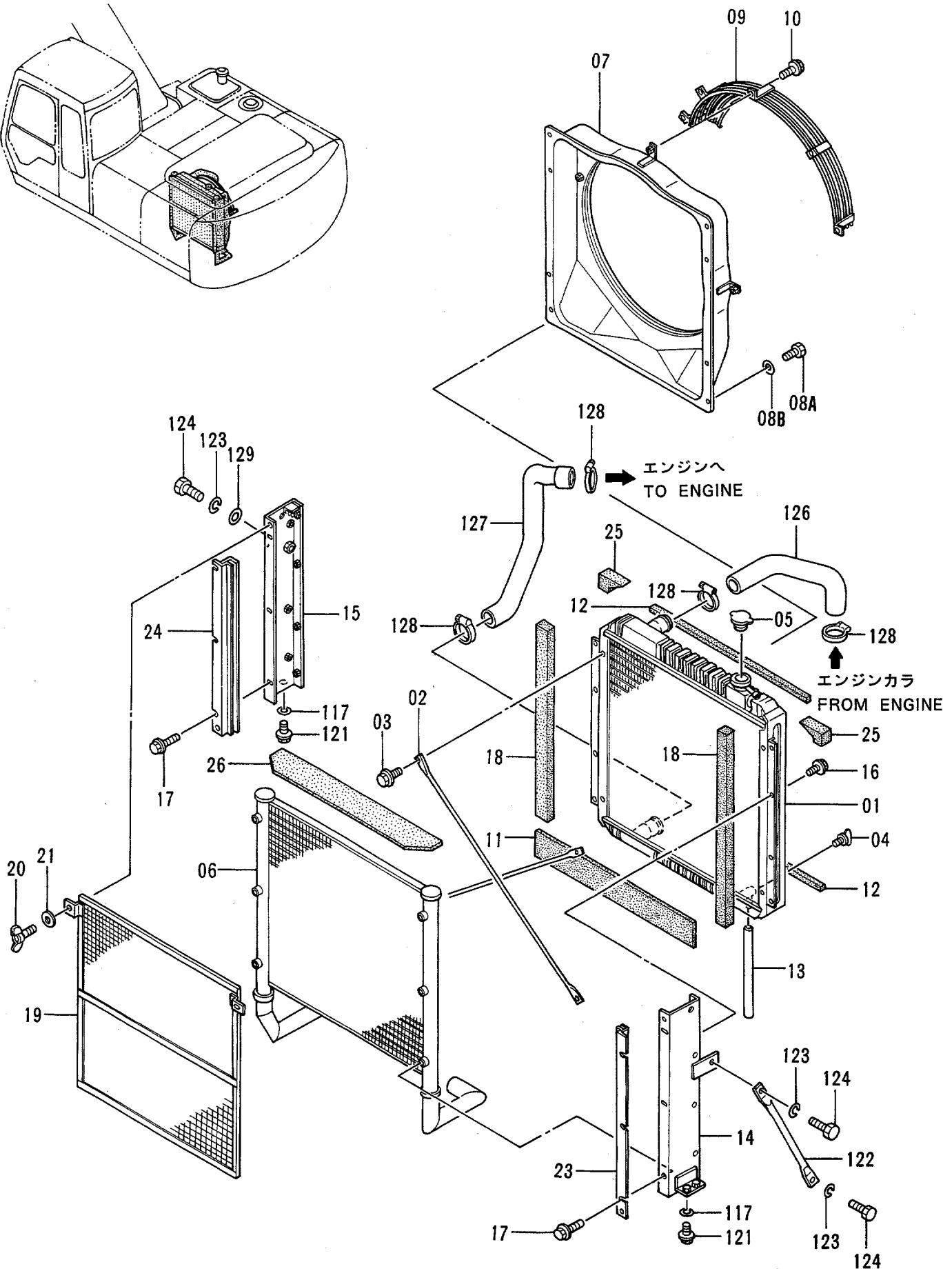
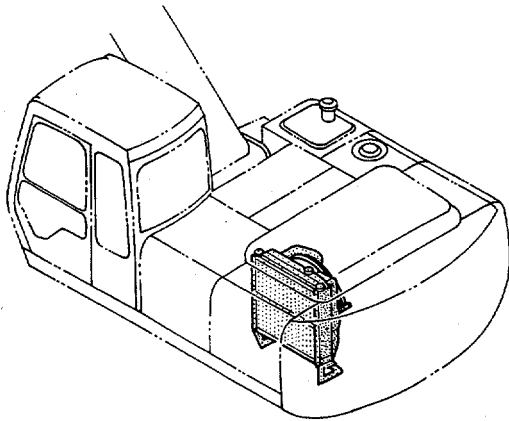

ラジエータ
RADIATOR

78001-

符号 ITEM	部品番号 PART NO.	部 品 名	PART NAME	数量 QTY	サービス コード S.C	通用号機 SERIAL NO.	互 換 性 ICA	代 替 部 品 REPLACEABLE PART	
								部品番号 PART NO.	数量 QTY
01-26	4276157	ラジエータ アツセン <STD>	RADIATOR ASS'Y <STD>	1					
01-26	4307779	ラジエータ アツセン <USA>	RADIATOR ASS'Y <USA>	1					
01	4287043	・コア;ラジエータ	・CORE;RADIATOR	1					
02	4287044	・ロッド	・ROD	2					
03	J020616	・ボルト;セムス	・BOLT;SEMS	4					
04	4206928	・プラグ;ドレーン	・PLUG;DRAIN	1					
05	4228160	・キャップ <STD>	・CAP <STD>	1					
05	4229974	・キャップ <USA>	・CAP <USA>	1					
06	4287045	・クーラ;オイル	・COOLER;OIL	1					
07	4287046	・ガイド;ファン	・GUIDE;FAN	1					
08A	J010814	・ボルト;セムス	・BOLT;SEMS	8					
08B	A590108	・ワッシャ;プレーン	・WASHER;PLANE	8					
09	4287047	・ガード;ファン	・GUARD;FAN	1					
10	J010816	・ボルト;セムス	・BOLT;SEMS	5					
11	4287053	・パッキン	・PACKING	1					
12	4287054	・パッキン	・PACKING	2					
13	4206927	・ホース	・HOSE	1					
14	4287048	・ブラケット	・BRACKET	1					
15	4287049	・ブラケット	・BRACKET	1					
16	J020816	・ボルト;セムス	・BOLT;SEMS	8					
17	J020816	・ボルト;セムス	・BOLT;SEMS	6					
18	4287055	・パッキン	・PACKING	2					
19	4287052	・ネット	・NET	1					
20	4206930	・ボルト;ウイング	・BOLT;WING	2					
21	4206931	・ワッシャ	・WASHER	2					
23	4287050	・ブラケット	・BRACKET	1					
24	4287051	・ブラケット	・BRACKET	1					
25	4287056	・パッキン	・PACKING	2					
26	4287057	・パッキン	・PACKING	1					
117	J222012	ワッシャ	WASHER	4					
121	J011235	ボルト;セムス	BOLT;SEMS	4					
122	4248560	ステー	STAY	1					
123	A590916	ワッシャ;スプリング	WASHER;SPRING	3					
124	J901635	ボルト	BOLT	3					
126	3048033	ホース;ウォーター	HOSE;WATER	1					
127	3050022	ホース;ウォーター	HOSE;WATER	1					
128	4504198	クランプ;ホース	CLAMP;HOSE	4		-83706	Y	4357297	4
128	4357297	クランプ;ホース	CLAMP;HOSE	4		83707-			
129	A590116	ワッシャ;プレーン	WASHER;PLANE	1					

リザーブタンク RESERVE TANK

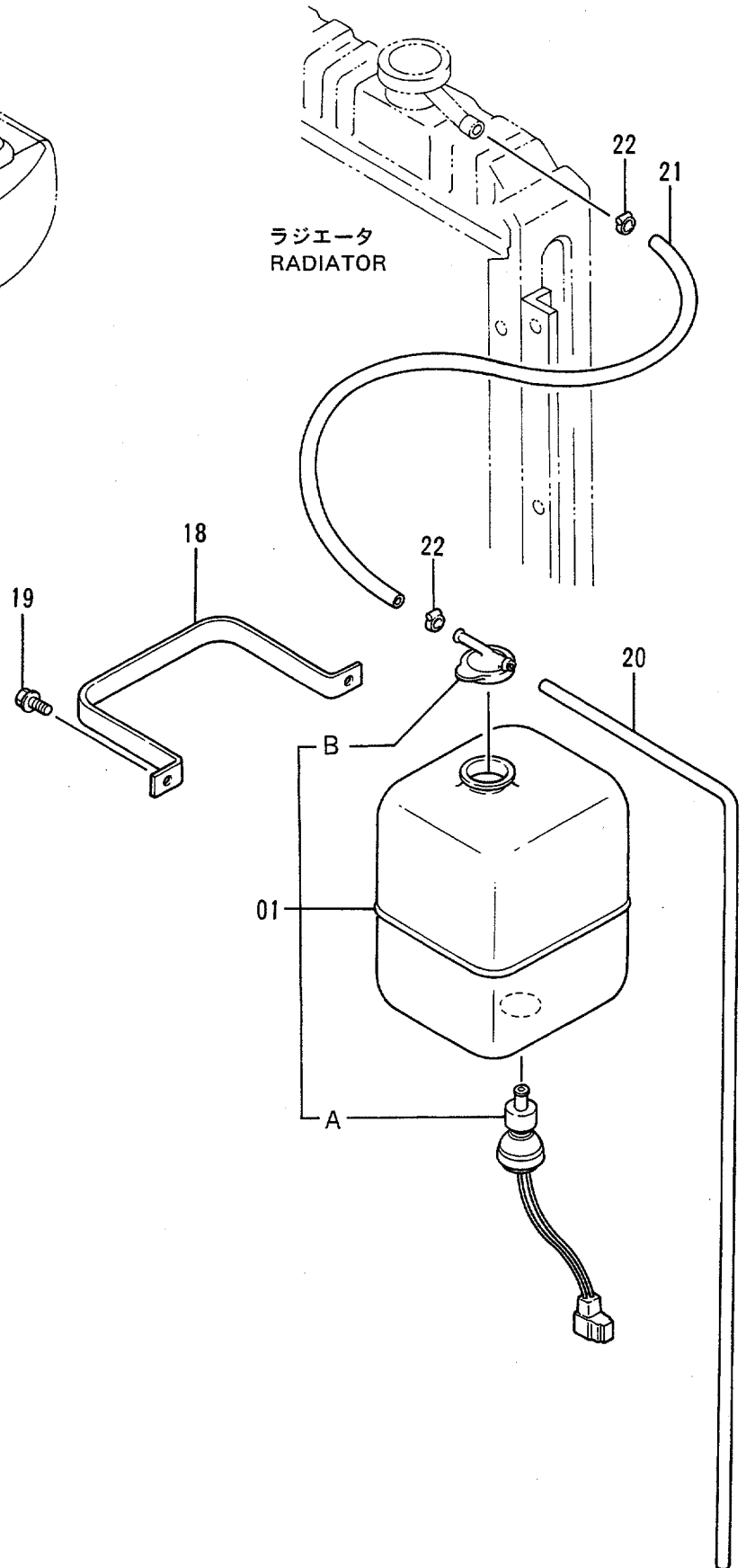
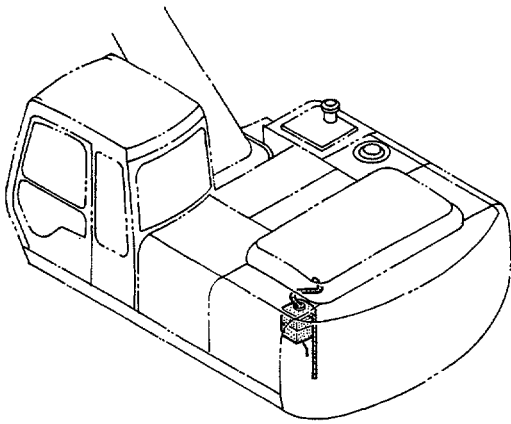

エアクリーナ AIR CLEANER

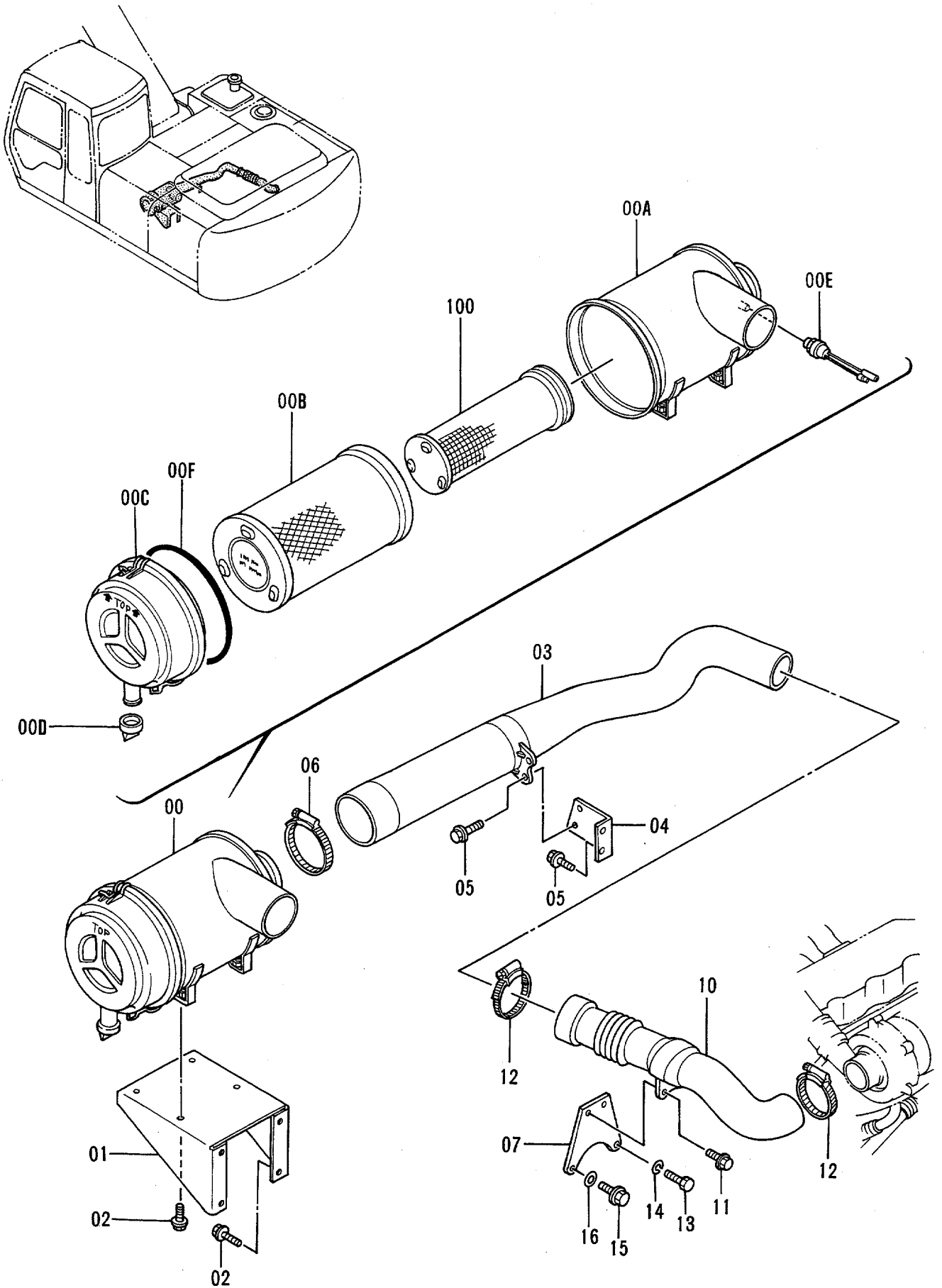

エア クリーナ
AIR CLEANER

78001-

符号 ITEM	部品番号 PART NO.	部 品 名	PART NAME	数量 QTY	サービス コード S. C	適用号機 SERIAL NO.	互 換 性 ICA	代 替 部 品 REPLACEABLE PART	
								部品番号 PART NO.	数量 QTY
00	4276158	クリーナ;エア アッセン	CLEANER;AIR ASS'Y	1					
00A	4287058	・ボデー	・BODY	1					
00B	4283861	・エレメント	・ELEMENT	1					
00C	4287059	・カバー	・COVER	1					
00D	4208275	・バルブ	・VALVE	1					
00E	4224238	・インジケータ	・INDICATOR	1					
00F	4324261	・O-リング	・O-RING	1					
01	3055204	ブラケット	BRACKET	1					
02	J021025	ボルト;セムス	BOLT;SEMS	8					
03	4271597	ダクト;エア	DUCT;AIR	1					
04	9736378	ブラケット	BRACKET	1					
05	J021030	ボルト;セムス	BOLT;SEMS	4					
06	4507397	クランプ;ホース	CLAMP;HOSE	1					
07	9735834	ブラケット	BRACKET	1					
10	4271598	ダクト;エア	DUCT;AIR	1					
11	J021030	ボルト;セムス	BOLT;SEMS	2					
12	4507512	クランプ;ホース	CLAMP;HOSE	2					
13	J900816	ボルト	BOLT	1					
14	A590908	ワッシャ;スプリング	WASHER;SPRING	1					
15	M171022	ボルト;セムス	BOLT;SEMS	1					
16	A590110	ワッシャ;プレーン	WASHER;PLANE	1					
100	4287060	エレメント <200, LC>	ELEMENT <200, LC>	1	OP				
100	4287060	エレメント <200H, LCH>	ELEMENT <200H, LCH>	1					

マフラー MUFFLER

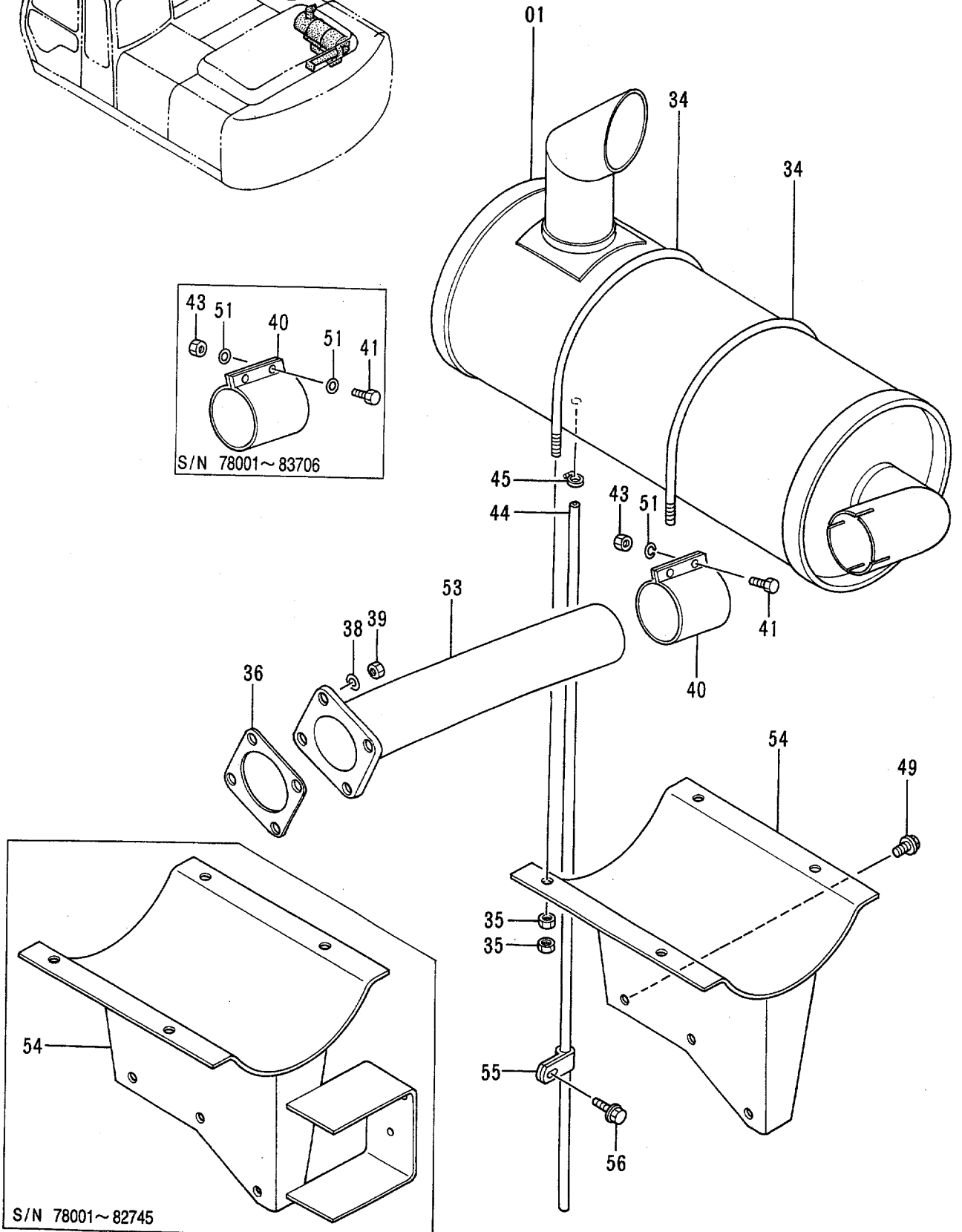
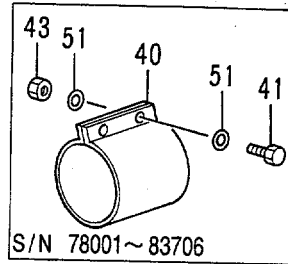
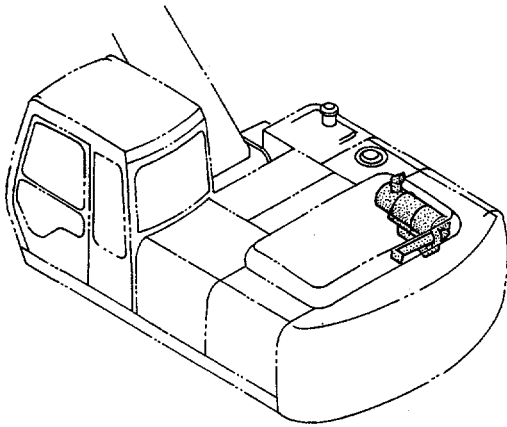

マフラー
MUFFLER

78001-

符号 ITEM	部品番号 PART NO.	部 品 名	PART NAME	数量 QTY	サービス コード S . C	適用号機 SERIAL NO.	互 換 性 ICA	代 替 部 品 REPLACEABLE PART	
								部品番号 PART NO.	数量 QTY
01	4256163	マフラー	MUFFLER	1					
34	4252533	ボルト;U	BOLT;U	2					
35	J950010	ナット	NUT	8					
36	4253965	ガスケット	GASKET	1					
38	A590910	ワッシャー;スプリング	WASHER;SPRING	4					
39	M521008	ナット	NUT	4					
40	4257014	クランプ	CLAMP	1					
41	M261260	ボルト	BOLT	2		-83706	Y	J901240	2
41	J901240	ボルト	BOLT	2		83707-			
43	J950012	ナット	NUT	2		-83706	Y	M520012	2
43	M520012	ナット	NUT	2		83707-			
44	4249788	チューブ	TUBE	1					
45	4508575	クランプ;ホース	CLAMP;HOSE	1					
49	J011035	ボルト;セムス	BOLT;SEMS	3					
51	J222012	ワッシャー	WASHER	4		-83706	Y	A590912	2
51	A590912	ワッシャー;スプリング	WASHER;SPRING	2		83707-			
53	7023241	パイプ;エキゾースト	PIPE;EXHAUST	1					
54	7024390	ブラケット	BRACKET	1		-82745	T	7030422	1
								8063346	1
								4055311	2
54	7030422	ブラケット	BRACKET	1		82746-			
55	4344303	クリップ	CLIP	1		78879-			
56	J011020	ボルト;セムス	BOLT;SEMS	1		78879-			

燃料配管 FUEL PIPINGS

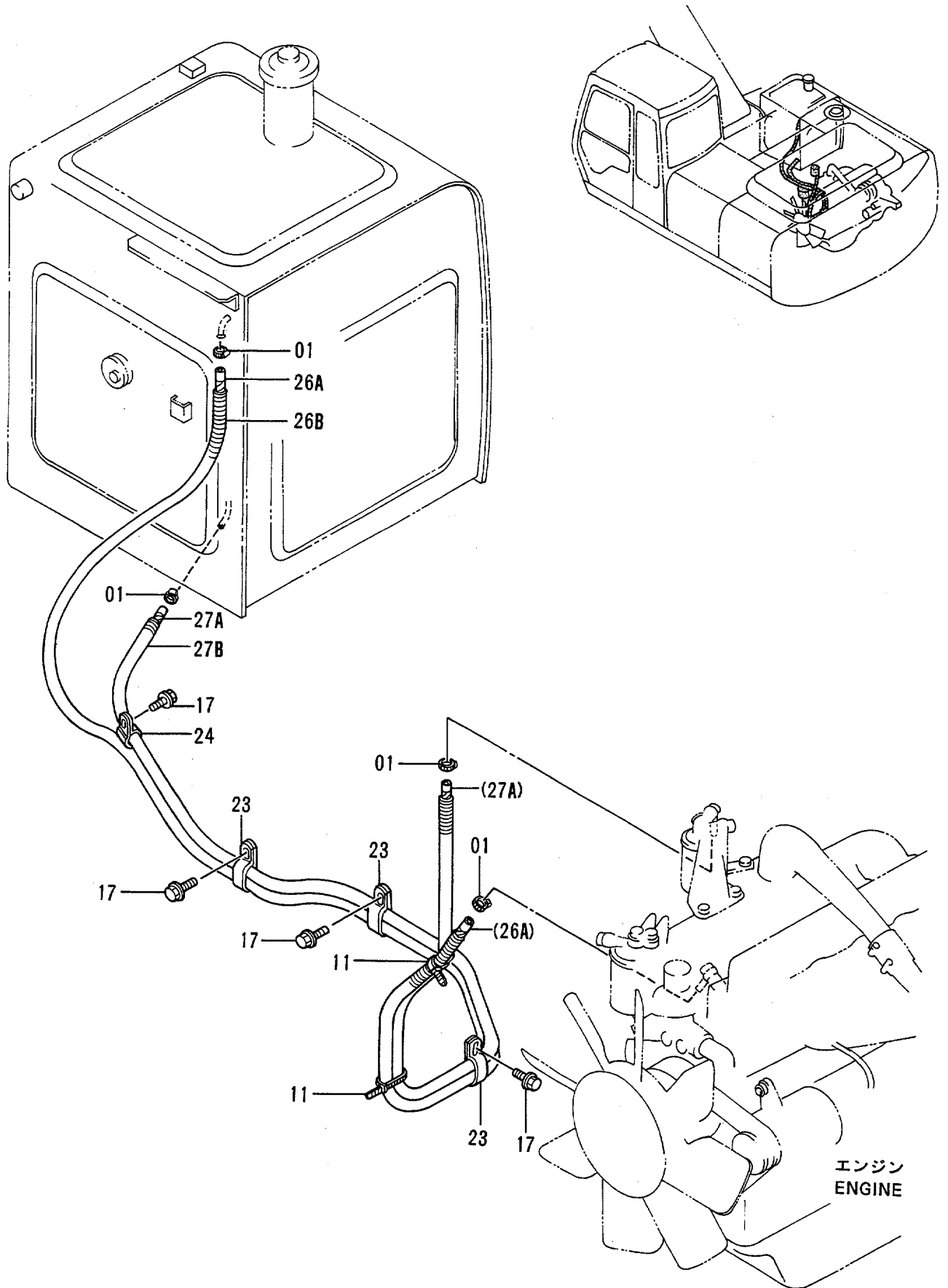

Thank you so much for reading.
Please click the “Buy Now!”
button below to download the
complete manual.



After you pay.

You can download the most
perfect and complete manual in
the world immediately.

Our support email:

ebooklibonline@outlook.com