

編 番
PART NO.
PI4C-EI-3

PARTS CATALOG

パーツカタログ

EX200-3

EX200LC-3

EX200H-3

EX200LCH-3

EQUIPMENT COMPONENTS PARTS

機器 インナーパーツ

適用号機 78001~
Serial No.

HITACHI

適 用 製 番 MACHINE Mfg. No.	
エ ン ジ ン 型 式 ENGINE TYPE	
エ ン ジ ン 製 番 ENGINE Mfg. No.	
備 考 REMARKS	

FOREWORD

- ◎ This parts catalog shows the precision parts of EX200-3, EX200LC-3, EX200H-3, EX200LCH-3 Hydraulic Excavator.
The numerical parts No. index is provided at the end of this parts catalog.
In the parts index, a part No. with "*" mark shows a newly added part on the parts catalog.
- ◎ This parts catalog contains the most recent information available at the time of printing, and the contents of the list are based on information in effect at that time and are subject to change without notice.
- ◎ The references in the parts catalog of "LEFT", "RIGHT", "FRONT" and "REAR" are identified as follows.
The driver's seat is positioned "LEFT" side, and the opposite side is "RIGHT".
The front-end attachments is at the "FRONT". The counterweight is attached at the "REAR".
For the undercarriage, the travel motor is at the "REAR", and the opposite is "FRONT".

1. HOW TO ORDER PARTS

When ordering parts, Please specify the following items as shown in the following example.

	(EXAMPLE)		
(1) Model of Machine	(EX200-3)	}	Shown on NAME-PLATE provided on MAIN FRAME on the lower right side of CAB
(2) Machine Serial No.	(14C-78001)		
(3) Part No.	(A810165)	}	Ordering Parts
(4) Part Name	(O-RING)		
(5) Q'ty	(2)		Ordering Q'ty
(6) Purchaser's Name and Address			

2. HOW TO USE THIS PARTS CATALOG

- ITEM Item No. shows the reference No. on the machine illustration.
- PART NO. Part No. consists of a letter of the alphabet and numerals, or numerals only.
- PART NAME Components of an assembly part are shown with "." marks and are shown on the line, or lines, below the assembly part. Also, if the component with "." mark consists of further components part, these further components are shown by the marks "...".

- Q' TY Q'ty shows the quantity used for a particular single hydraulic unit, however quantity of components shows the quantity for one assembly part.
- SERVICE CODE Abbreviations in the column of service code have their own meaning as shown below.
- W: The part with this abbreviation shows that the part requires some work on it before installing in the machine.
 - D: The part with this abbreviation is a component of an assembly and is not available independently. The assembly part containing this part should be ordered.
 - K: This means that the part is contained in the service parts kit.
 - R: The part with this abbreviation shows that the quantity of the part is changed depending upon the machine, such as an adjusting shim etcetera.
 - S: This part is specially provided as a service part, which was not provided in the machine before from shipping the factory.
 - OP: Optional parts
 - OS: Over-sized parts
 - US: Under-sized parts
- (NOTE: Part with abbreviation "OS" or "US" is described on the line below the standard-sized part.)
- #: The part with this mark is newly added on that page of the equipment.
- SERIAL No. Applicable machine serial No. for the part is shown in this column. Further, above this column, the applicable serial No. is shown for all parts described on that page.
- Take this serial No. if the part is not mentioned its own applicable serial No. Take the serial No. which includes both of for the part and for all parts described on the page if the part is mentioned its own applicable serial No. If the abbreviation "D" is described as headed letter instead of the serial No. it means the produced date of the machine in which the parts are used. (EXAMPLE: D94/01-.....produced on January 1994 and after)
- If the abbreviation "H" is described as headed letter, it means the serial No. of equipment such as PUMP, MOTOR, CONTROL VALVE and etcetera.
- If the abbreviation "F" is described as headed letter, it means the Front No. of front-end attachments such as BUCKET, BOOM, ARM and etcetera.
- ICA ICA shows the interchangeability between the original and the improved parts. Abbreviations used in this column are as follows.
- I: Part No. in the column of "Replaceable part" can be used instead of this part but not vice versa.
 - P: This must not be used for the machine. The part No. in the column "Replaceable part" should be used instead.
 - T: Parts Nos. those in the column of "Replaceable part" can be used as an assembly instead of this part.
 - Y: This part and the part in the column of "Replaceable part" are interchangeable with each other.

·REPLACEABLE PART

Interchangeable parts Nos. and their required quantity are shown in this column.

NOTE: If interchangeable improved parts are provided for the parts which you may order, the improved parts classified as 'I', 'P', 'T' or 'Y' may be supplied.

目 次
CONTENTS

P B - 1 3 2
P B - A 1 8

部品番号 PART NO.	コード CODE	部 品 名	PART NAME	適用号機 SERIAL NO.	頁 PAGE
ポンプ			P U M P		
9118971	9118971A	ポンプ ; ダブル	PUMP;DOUBLE		001
++++++	9118972A	・ポンプ ; ユニット	・PUMP;UNIT		003
++++++	9128251A	・ ・ センサ ; アンクル	・ ・ SENSOR;ANGLE		005
4276918	0450900B	・ポンプ ; ギヤ	・PUMP;GEAR		007
モータ ; オイル			M O T O R ; O I L		
9120000	9120000A	モータ ; オイル (走行)	MOTOR;OIL (TRAVEL)		009
9119999	9119999A	・バルブ ; ブレーキ	・VALVE;BRAKE		011
9134147	9134147A	・ ・ バルブ ; リリーフ	・ ・ VALVE;RELIEF		013
9101386	9101386A	・ピストン ; サーボ	・PISTON;SERVO		015
4308814	0620600A	モータ ; オイル (旋回)	MOTOR;OIL (SWING)		017
バルブ			V A L V E		
4327129	-----	バルブ ; コントロール	VALVE;CONTROL	78001-78012	---
++++++	0618300	・バルブ ; コントロール (1/6)	・VALVE;CONTROL (1/6)		019
++++++	0618400	・バルブ ; コントロール (2/6)	・VALVE;CONTROL (2/6)		021
++++++	0618500	・バルブ ; コントロール (3/6)	・VALVE;CONTROL (3/6)		023
++++++	0618600	・バルブ ; コントロール (4/6)	・VALVE;CONTROL (4/6)		025
++++++	0618700	・バルブ ; コントロール (5/6)	・VALVE;CONTROL (5/6)		027
++++++	0618800	・バルブ ; コントロール (6/6)	・VALVE;CONTROL (6/6)		029
4296348	-----	バルブ ; コントロール	VALVE;CONTROL	STD:78013-78530 78534, 78537-78570 LC :78013-78418	---
++++++	0617000	・バルブ ; コントロール (1/6)	・VALVE;CONTROL (1/6)		031
++++++	0617100	・バルブ ; コントロール (2/6)	・VALVE;CONTROL (2/6)		033
++++++	0617200	・バルブ ; コントロール (3/6)	・VALVE;CONTROL (3/6)		035
++++++	0617300	・バルブ ; コントロール (4/6)	・VALVE;CONTROL (4/6)		037
++++++	0617400	・バルブ ; コントロール (5/6)	・VALVE;CONTROL (5/6)		039
++++++	0617500	・バルブ ; コントロール (6/6)	・VALVE;CONTROL (6/6)		041
4330205	-----	バルブ ; コントロール	VALVE;CONTROL	STD:78531-78533 78535-78536 78571- LC :78419-	---
++++++	0632300	・バルブ ; コントロール (1/6)	・VALVE;CONTROL (1/6)		043
++++++	0632400	・バルブ ; コントロール (2/6)	・VALVE;CONTROL (2/6)		045
++++++	0632500	・バルブ ; コントロール (3/6)	・VALVE;CONTROL (3/6)		047
++++++	0632600	・バルブ ; コントロール (4/6)	・VALVE;CONTROL (4/6)		049

部品番号 PART NO.	コード CODE	部品名	PART NAME	適用号機 SERIAL NO.	頁 PAGE
+++++	0632700	・バルブ ; コントロール (5/6)	・VALVE;CONTROL (5/6)		051
+++++	0632800	・バルブ ; コントロール (6/6)	・VALVE;CONTROL (6/6)		053
9134232	9134232B	バルブ ; パイロット	VALVE;PILOT		055
9101512	9101512B	バルブ ; パイロット	VALVE;PILOT		057
9072923	9072923E	バルブ ; パイロット	VALVE;PILOT		059
4331026	0615200A	バルブ ; ソレノイド	VALVE;SOLENOID		061
4327243	0614200A	バルブ ; フロウコントロール	VALVE;FC.		063
4325812	0614100A	バルブ ; フロウコントロール	VALVE;FC.		065
4254613	0408500A	バルブ ; シャトル	VALVE;SHUTTLE		067
4254611	0396600B	バルブ ; ロック	VALVE;LOCK		069
4311303	0644400	バルブ ; ホールディング	VALVE;HOLDING		071
4311304	0644500	バルブ ; ホールディング	VALVE;HOLDING		073
4311305	0644600	バルブ ; ホールディング	VALVE;HOLDING		075
4282545	0672700	バルブ ; ロータリ	VALVE;ROTARY		077
4288149	0437600A	バルブ	VALVE		079
シリンダ			CYLINDER		
4250223	0409700A	シリンダ ; ブーム (右)	CYL.;BOOM (R)		081
4250224	0409800A	シリンダ ; ブーム (左)	CYL.;BOOM (L)		083
4314778	0481800A	シリンダ ; アーム	CYL.;ARM		085
4250225	0410000A	シリンダ ; バケット	CYL.;BUCKET		087
4287889	0437000A	シリンダ ; バケット <スパーロンゲ>	CYL.;BUCKET <RIVER MAINTENANCE>		089
4288743	0496700A	シリンダ ; クラムシェル	CYL.;CLAMSHELL		091
その他			ETC.		
9101532	9101532B	センサ ; DP	SENSOR;DP		093
索引			PARTS INDEX		095

001A

ポンプ ;ダブル
PUMP ;DOUBLE

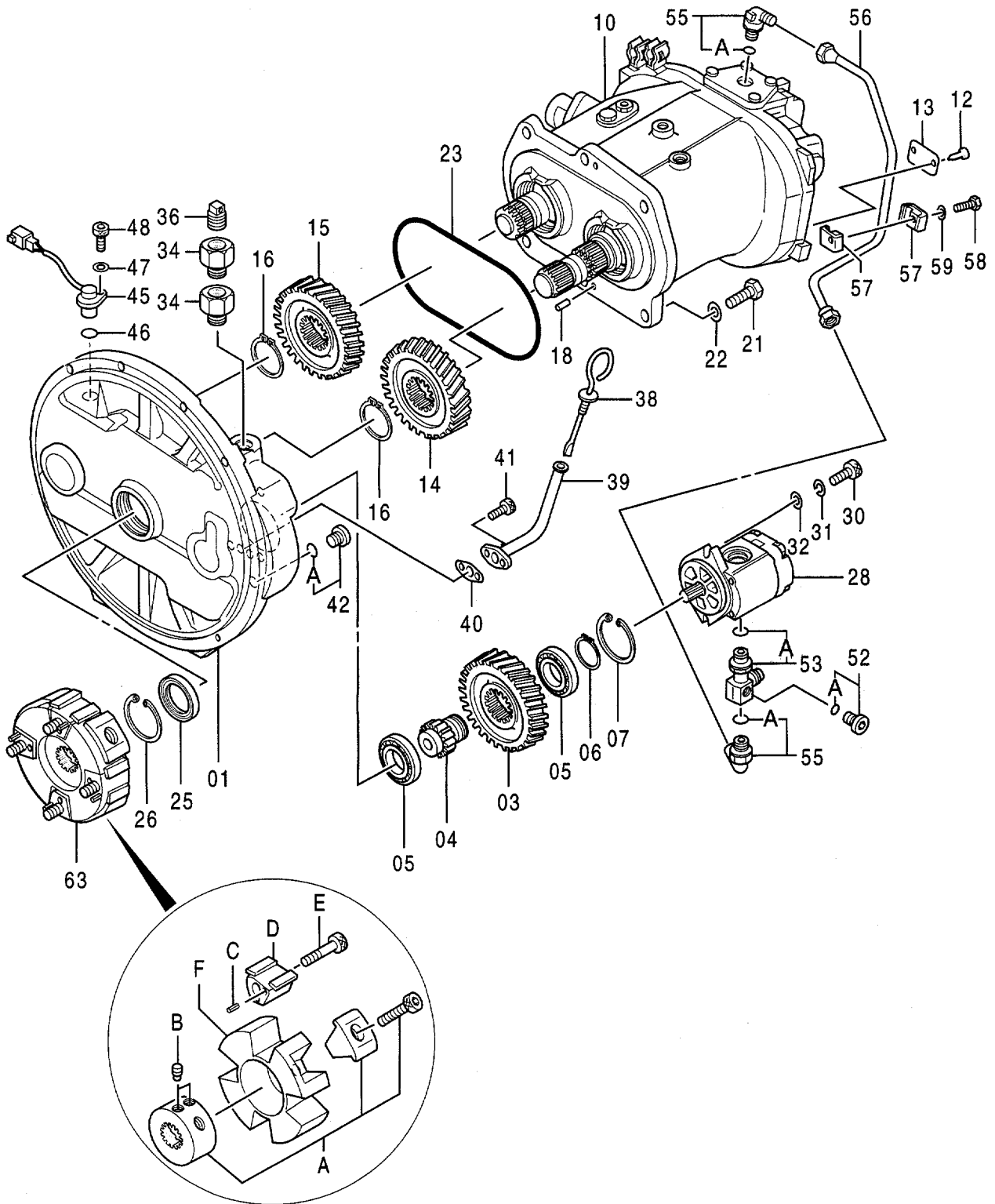

ポンプ;ダブル
PUMP;DOUBLE

78001-

符号 ITEM	部品番号 PART NO.	部品名 PART NAME	コード CODE	数量 QTY	サービス コード S.C	適用号機 SERIAL NO.	互換性 ICA	代替部品 REPLACEABLE PART	
								部品番号 PART NO.	数量 QTY
	9118971	PUMP;DOUBLE <for assembly of machine>	9118971A	1			1	9133006	1
	(9133006)	PUMP;DOUBLE <for transportation>		1	S				
01	1018749	・CASING;GEAR		1					
03	3063840	・GEAR;PILOT		1					
04	3055594	・SHAFT;GEAR		1					
05	958740	・BRG.;BALL		2					
06	962002	・RING;RETAINING		1					
07	991725	・RING;RETAINING		1					
10	+++++	・PUMP;UNIT	9118972A	1	D				
12	M492564	・SCREW;DRIVE		2					
13	3069408	・NAME-PLATE		1					
14	3063842	・GEAR		1					
15	3063843	・GEAR		1					
16	4274552	・RING;RETAINING		2					
18	4099290	・PIN;SPRING		2					
21	M211645	・BOLT		6					
22	A590916	・WASHER;SPRING		6					
23	4317619	・O-RING		1					
25	4310055	・SEAL;OIL		1					
26	991725	・RING;RETAINING		1					
28	4276918	・PUMP;GEAR	0450900B	1					
30	M341028	・BOLT;SOCKET		2					
31	984054	・WASHER;SPRING		2					
32	4114402	・WASHER		2					
34	4317633	・ADAPTER		2					
36	4234782	・PLUG		1					
38	4242263	・GAUGE;LEVEL		1		-H0625	1	4340855	1
38	4340855	・GAUGE;LEVEL		1		H0626-			
39	9736788	・PIPE		1					
40	4243160	・PACKING		1					
41	M340816	・BOLT;SOCKET		2					
42	9134111	・PLUG		1					
42A	4509180	・O-RING		1					
45	4265372	・SENSOR;REVOL.		1					
46	4306888	・O-RING		1					
47	A590106	・WASHER;PLANE		1					
48	M340616	・BOLT;SOCKET		1					
52	9134110	・PLUG		1					

001B

ポンプ;ダブル
PUMP;DOUBLE

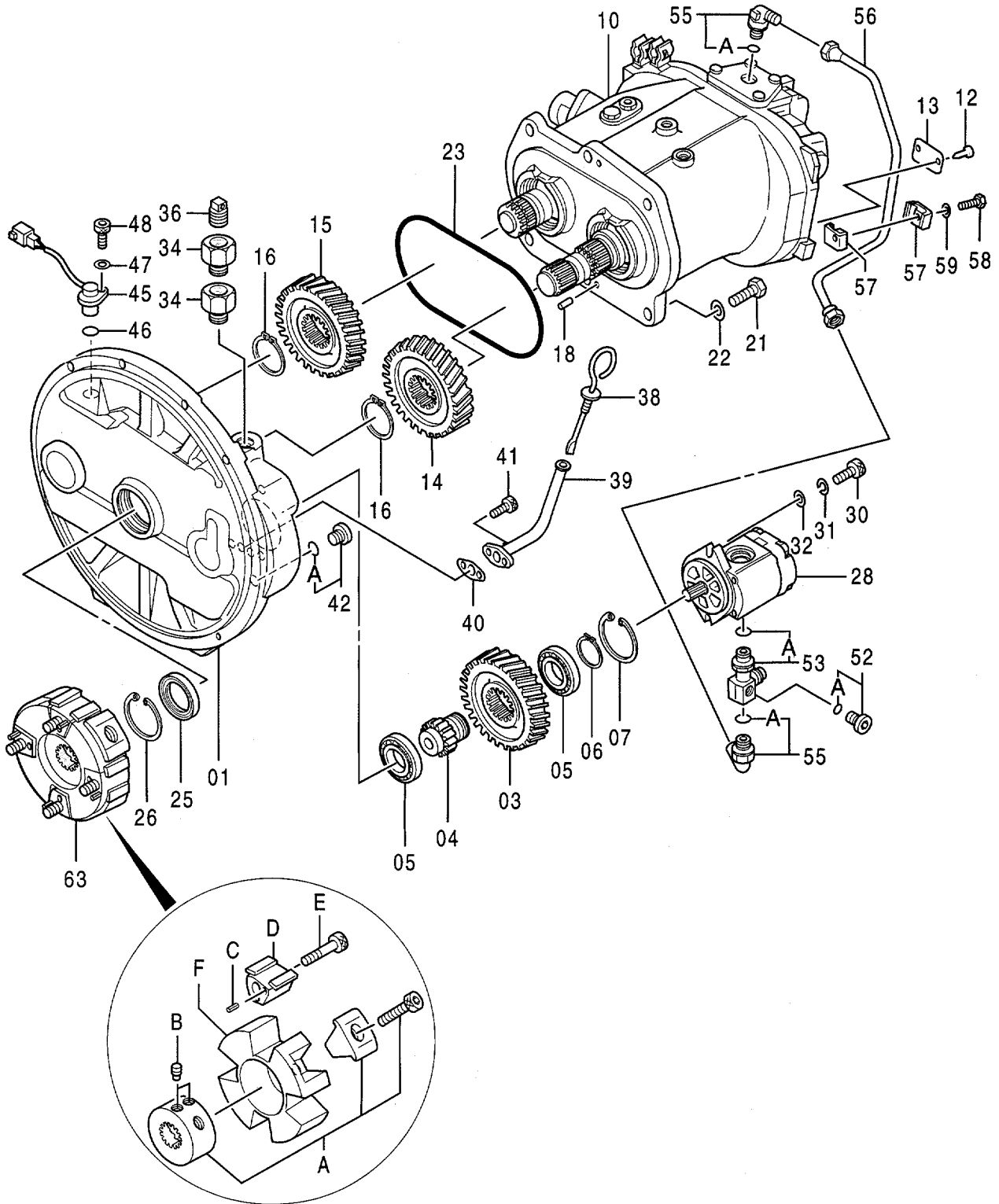

003A

ポンプ ; ユニット
PUMP ; UNIT

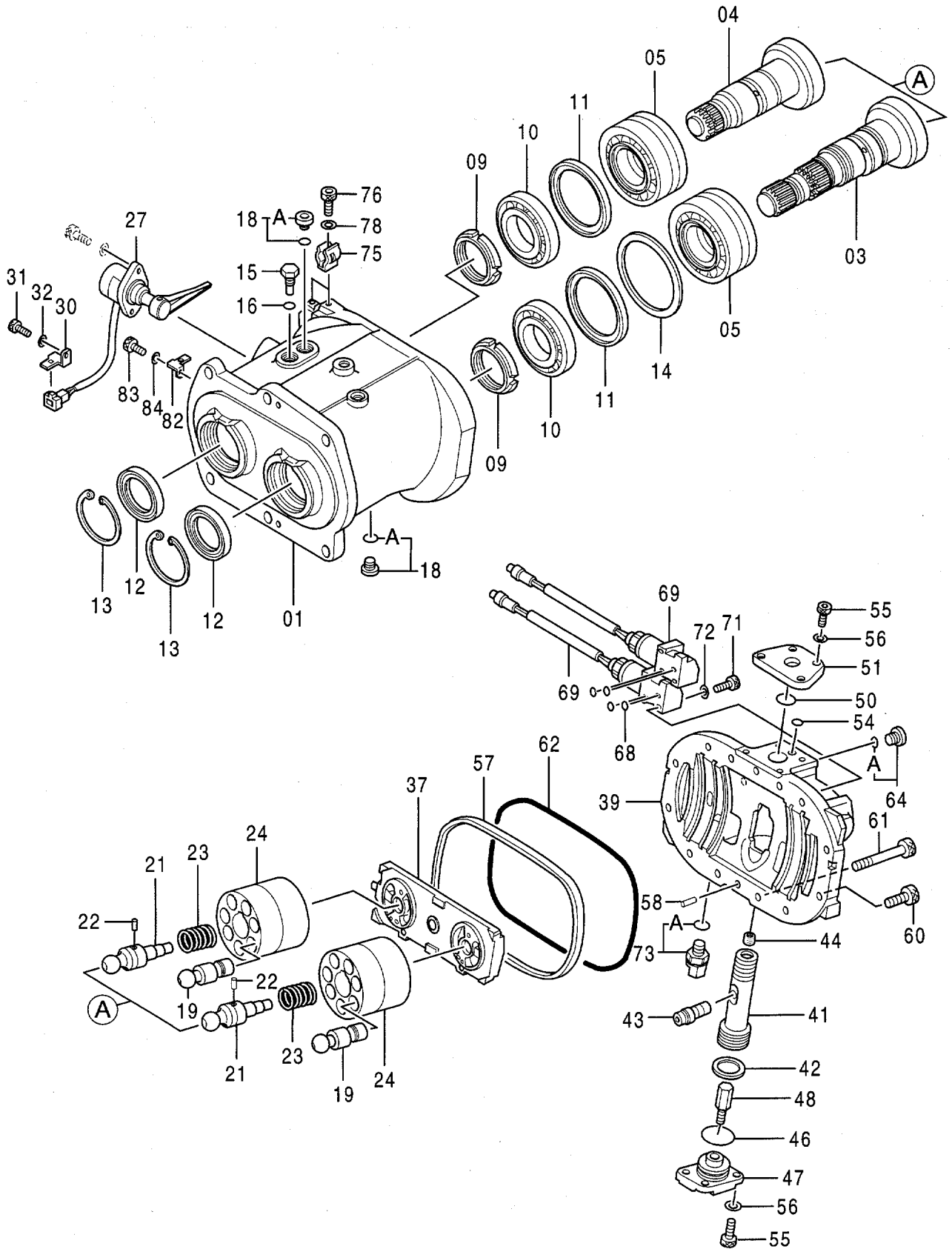

ポンプ;ユニット
PUMP;UNIT

78001-

符号 ITEM	部品番号 PART NO.	部品名 PART NAME	コード CODE	数量 Q'TY	サービス コード S.C	適用号機 SERIAL NO.	互換性 ICA	代替部品 REPLACEABLE PART	
								部品番号 PART NO.	数量 Q'TY
01	++++++ 1018750	PUMP;UNIT ・CASING;PUMP	9118972A	1 1	D	-H05749			
01	1022032	・CASING;PUMP		1	#	H05750-	I	1018750	1
03	2034788	・DISC;DRIVING		1					
04	2034789	・DISC;DRIVING		1					
05	4175666	・BRG.;ROL.		2					
09	4178173	・NUT;BRG.		2					
10	4199307	・BRG.;ROL.		2					
11	4339171	・RING		2					
12	4232069	・SEAL;OIL		2					
13	4116290	・RING;RETAINING		2					
14	4338907	・RING;THRUST		1					
15	4310992	・PLUG		2					
16	957366	・O-RING		2					
18	9134111	・PLUG		3					
18A	4509180	・O-RING		1					
19	8043698	・PISTON		14					
21	4233180	・SHAFT;CENTER		2					
22	4198956	・PIN		2					
23	4248499	・SPRING;COMPRES.		2					
24	2027277	・ROTOR		2					
27	++++++	・SENSOR;ANGLE	9128251A	1	D				
30	4252767	・BRACKET		1					
31	M340613	・BOLT;SOCKET		1					
32	4169516	・WASHER;SPRING		1					
37	1020223	・VALVE		1					
39	1018752	・HEAD		1		-H04813	P	1022034	1
39	1022034	・HEAD		1	#	H04814-			
41	3055313	・PISTON;SERVO		1					
42	4272674	・RING;PISTON		1					
43	4260211	・PIN		1					
44	4179838	・SCREW;SET		1					
46	4317635	・O-RING		1					
47	4260500	・STOPPER		1					
48	4260493	・STOPPER		1					
50	4317637	・O-RING		1					
51	4311778	・COVER		1					
54	4317636	・O-RING		1					
55	M340820	・BOLT;SOCKET		8					
56	4514388	・WASHER;SPRING		8					

003B

ポンプ ;ユニット
PUMP ; UNIT

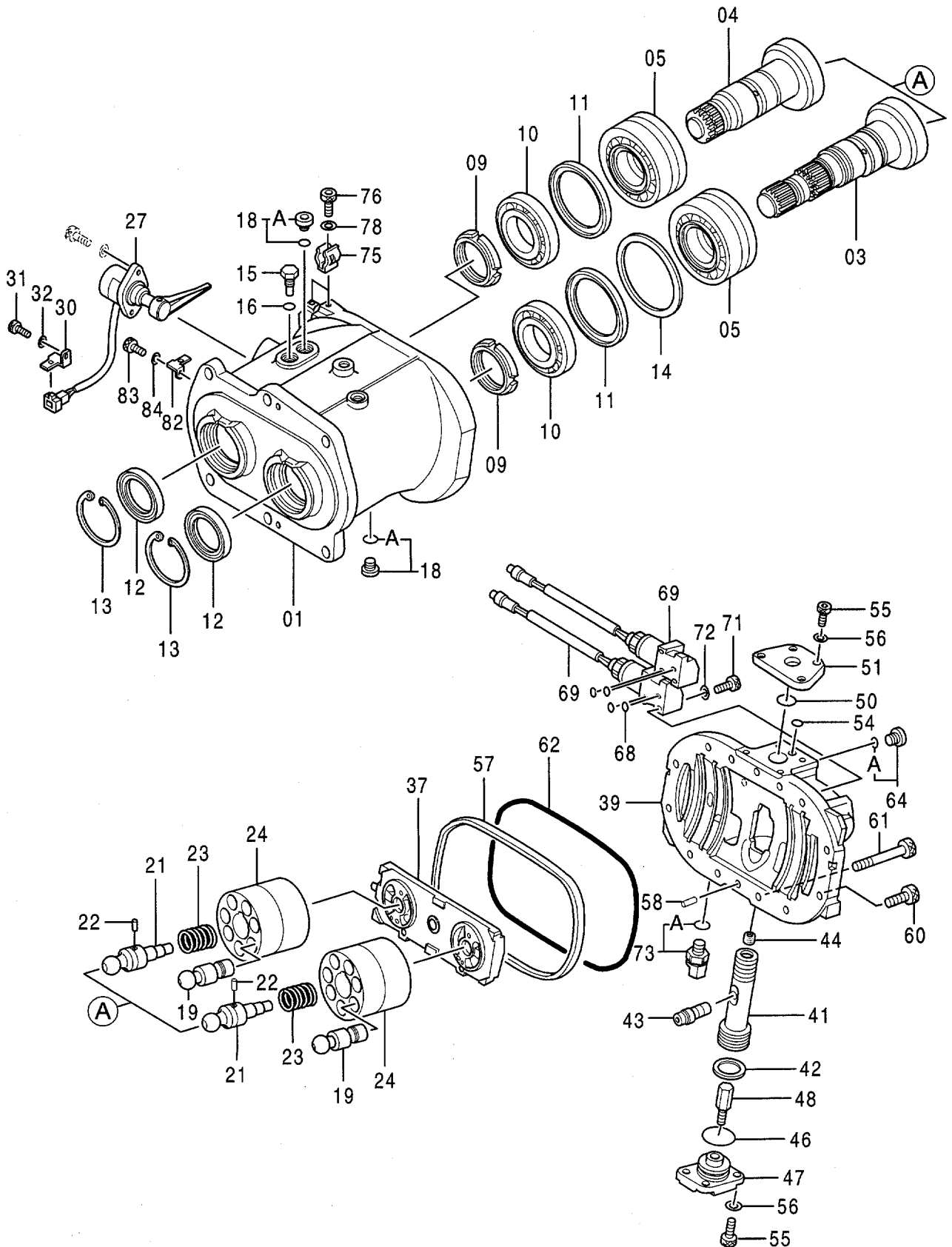

9118972A

Thank you so much for reading.
Please click the “Buy Now!”
button below to download the
complete manual.



After you pay.

You can download the most
perfect and complete manual in
the world immediately.

Our support email:

ebooklibonline@outlook.com