

PARTS MANUAL

CHALLENGER

**H6.00-7.00XL
(F006)**

CUSTOMER EDITION

HYSTER

SECTIONS

1	FRAME
2	ENGINES
3	FUEL SYSTEM
4	ELECTRICAL SYSTEM
5	TRANSMISSION
6	STEERING SYSTEM
7	BRAKE SYSTEM
8	HYDRAULIC SYSTEM
9	MAST-TWO STAGE LIMITED FREE-LIFT
10	MAST-THREE STAGE FULL FREE-LIFT
11	OPTIONS
12	NUMERICAL INDEX

TABLE OF CONTENTS

DESCRIPTION	PAGE
A	
ACTUATOR.....	7-18
AIR FILTER	
HEAVY DUTY	
DIESEL.....	3-72
PETROL AND LPG	3-68
STANDARD	
⇒S/N F006A-7082	3-62
S/N F006A-7083⇒.....	3-64
ALTERNATOR	
DELCO BRAND	
⇒D/B 07/1994.....	4-76
GASOLINE, LPG AND DIESEL	
D/B 07/1994⇒.....	4-80
OPTIONAL.....	4-86
PRESTOLITE BRAND.....	4-82
ALTERNATOR MOUNTING	
DIESEL 1004.42	
WITH LOW EMISSIONS	4-88
AUXILIARY DRIVE GEAR	
DIESEL 1004.4	
⇒S/N F006A-10149.....	2-202
AXLE HOUSING AND ATTACHING PARTS	
S/N F006A-11220⇒.....	5-57
B	
BACK-UP ALARM	11-62
BATTERY DISCONNECT	
EEC.....	4-52
BRAKE	
⇒S/N F006A-3184.....	7-12
S/N F006A-3185↔S/N F006A-4792.....	7-14
S/N F006A-4793⇒.....	7-16
BRAKE LINES.....	7-4
BRAKE PEDAL LINKAGE	
OIL CLUTCH.....	7-6
POWERSHIFT	7-8
C	
CAB	
⇒S/N F006A-8145.....	11-2
S/N F006A-8146⇒.....	11-6
CAMSHAFT AND CRANKSHAFT	
PETROL AND LPG	
1986 THRU 1989 SERIES ENGINE	2-98
1990 THRU 1991 SERIES ENGINE	
⇒S/N F006A-7082	2-102
2KM 1992 SERIES MOTOR	
S/N F006A-7083⇒	2-106
3KM 1993 SERIES MOTOR.....	2-110
4LM 1994 SERIES MOTOR.....	2-114

TABLE OF CONTENTS (Continued)

DESCRIPTION	PAGE
C (continued)	
CAMSHAFT AND OIL SUMP	
PETROL AND LPG	
1996 THRU 1999 SERIES ENGINE	2-118
2000 THRU 2004 SERIES ENGINE	2-122
5LM 1995 SERIES MOTOR	2-116
CARBURETOR	
LPG	
⇒S/N F006A-8488	3-34
S/N F006A-8489⇒	3-36
PETROL	
⇒S/N F006A-7082	3-40
CARRIAGE	
PIN TYPE	
THREE STAGE FULL FREE-LIFT	10-22
TWO STAGE LIMITED FREE-LIFT	9-12
CHOKE	3-42
CLUTCH	
OIL CLUTCH	
⇒D/B 09/1997	5-12
CLUTCH LINKAGE	
OIL CLUTCH	
⇒D/B 09/1997	5-18
CLUTCH PACK	
POWERSHIFT	
D/B 09/1997⇒	5-30
⇒D/B 09/1997	5-28
DIRECTIONAL	
D/B 09/1997⇒	5-32
CONTROL LINKAGE	
OIL CLUTCH	
FORWARD/REVERSE LEVER	
S/N F006A-3791⇒	5-16
⇒S/N F006A-3790	5-14
POWERSHIFT	
⇒S/N F006A-3790	5-40
S/N F006A-3791⇒	5-44
CONTROL VALVE	
FOUR FUNCTION	
⇒S/N F006A-10791	8-40
S/N F006A-10792⇒	8-44
POWERSHIFT	5-34
THREE FUNCTION	
⇒S/N F006A-10791	8-34
TWO AND THREE FUNCTION	
S/N F006A-10792⇒	8-42
TWO FUNCTION	
⇒S/N F006A-10791	8-28
CONTROL VALVE ATTACHING PARTS	
FOUR FUNCTION	
⇒S/N F006A-10791	8-36

TABLE OF CONTENTS (Continued)

DESCRIPTION	PAGE
C (continued)	
S/N F006A-10792⇒	8-50
THREE FUNCTION	
⇒S/N F006A-10791	8-30
TWO AND THREE FUNCTION	
S/N F006A-10792⇒	8-46
TWO FUNCTION	
⇒S/N F006A-10791	8-25
CONTROL VALVE ATTACHING TUBES	
TWO, THREE, AND FOUR FUNCTION	
S/N F006A-10792⇒	8-52
COOLANT PUMP	
DIESEL 1004.4	
S/N F006A-3040⇔S/N F006A-10149	2-196
DIESEL 1004.42	
S/N F006A-10150⇒ ⇒S/N U892125D	2-198
DIESEL 4.284.2	
⇒S/N F006A-3039	2-194
DIESEL WITH LOW EMISSIONS	
S/N U892126D⇒	2-200
COOLING	
DIESEL	2-134
PETROL AND LPG	
⇒S/N F006A-8275	2-20
S/N F006A-8276⇒	2-24
SERPENTINE	
PETROL AND LPG	
S/N F006A-8489⇒	2-28
COUNTERWEIGHT	1-26
COWL AND FLOOR PLATES	1-16
CRANKSHAFT AND PISTON	
DIESEL 1004.4	
S/N F006A-3040⇔S/N F006A-10159	2-158
DIESEL 1004.42	
S/N F006A-10150⇒	2-160
DIESEL 4.248.2	
⇒S/N F006A-3039	2-156
CYLINDER BLOCK	
DIESEL 1004.4	
S/N F006A-3040⇔S/N F006A-10149	2-144
DIESEL 1004.42	
S/N F006A-10150⇒	2-148
DIESEL 4.248.2	
⇒S/N F006A-3039	2-142
PETROL AND LPG	
2000 THRU 2004 SERIES ENGINE	2-54
2KM 1992 SERIES MOTOR	
S/N F006A-7083⇒	2-40
3KM 1993 SERIES MOTOR	2-44
4LM 1994 SERIES MOTOR	2-46
5LM 1995 SERIES MOTOR	2-48

TABLE OF CONTENTS (Continued)

DESCRIPTION	PAGE	
C (continued)		
6KM 1986, 7KM 1987, 8KM 1988, 9KM 1989 SERIES MOTOR	2-32	
6LX 1996, 7LX 1997, 8LX 1998, 9LX 1999 SERIES MOTOR	2-50	
⇒S/N F006A-7082	2-36	
CYLINDER HEAD		
DIESEL 1004.4		
S/N F006A-3040⇔S/N F006A-10149	2-152	
DIESEL 1004.42		
S/N F006A-10150⇒	2-154	
DIESEL 4.248.2		
⇒S/N F006A-3039	2-150	
PETROL AND LPG		
1990 THRU 1991 SERIES ENGINE		
⇒S/N F006A-7082	2-62	
2000 THRU 2004 SERIES ENGINE		2-80
2KM 1992 SERIES MOTOR	2-66	
3KM 1993 SERIES MOTOR	2-70	
4LM 1994 SERIES MOTOR	2-74	
5LM 1995 SERIES MOTOR	2-76	
6KM 1986, 7KM 1987, 8KM 1988, 9KM 1989 SERIES MOTOR	2-58	
6LX 1996, 7LX 1997, 8LX 1998, 9LX 1999 SERIES MOTOR	2-78	
D		
DIFFERENTIAL		
OIL CLUTCH		
⇒S/N F006A-1704	5-58	
S/N F006A1705⇒ D/B 09/1997	5-62	
POWERSHIFT		
⇒S/N F006A-1754	5-66	
S/N F006A-1755⇒	5-70	
DIFFERENTIAL AND CARRIER		
S/N F006A-11220⇒	5-74	
DIRECTION SWITCH		
⇒S/N F006A-6480	5-48	
S/N F006A-6481⇒	5-50	
DISTRIBUTOR		
⇒S/N F006A-7082	4-90	
SHEET 1 OF 2	4-92	
SHEET 2 OF 2	4-94	
DRIVE AXLE		5-54
DRIVE SHAFT		8-58
DRIVE SHAFT ASSEMBLY		5-77
DROP BOX		
OIL CLUTCH		
⇒D/B 09/1997	5-8	
E		
ELECTRICAL		
LPG		
S/N F006A-10288⇒	4-26	

TABLE OF CONTENTS (Continued)

DESCRIPTION	PAGE
E (continued)	
PETROL	
S/N F006A-10288⇒	4-28
ELECTRICAL SYSTEM	
DIESEL	
⇒D/B 09/1997	4-40
POWERSHIFT	
D/B 03/1998⇔S/N F006A-11425Y	4-44
WITH POWERSHIFT	
S/N F006A-1612Y⇒	4-48
LPG	
S/N F006A-08489⇒	4-38
S/N F006A-7083⇔S/N F006A-10287	4-36
PETROL	
S/N F006A-7083⇒	4-14
S/N F006A-8489⇔S/N F006A-10431	4-30
PETROL AND LPG	
S/N F006A-10288⇒	4-22
⇒S/N F006A-7082	4-4
S/N F006A-7083⇒	4-8
S/N F006A-8489⇔S/N F006A-10287	4-18
ENGINE CONTROL	
PETROL	
SHEET 1 OF 2	
S/N F006A-10432⇒	4-32
SHEET 2 OF 2	
S/N F006A-10432⇒	4-34
EXHAUST	
WITH CAB	2-12
WITHOUT CAB	2-16
F	
FILTER AND LOCK-OFF VALVE	3-46
FIRE EXTINGUISHER	11-9
FLOW REGULATOR	
HEAVY DUTY	6-28
FLYWHEEL	2-8
FORK	
PIN TYPE	11-18
FREE-LIFT	
THREE STAGE FULL FREE-LIFT	10-12
FUEL INJECTION	
DIESEL	
⇒S/N F006A-3039	3-88
DIESEL 1004.4	
S/N F006A-3040⇔S/N F006A-10149	3-90
DIESEL 1004.42	
S/N F006A-10150⇒	3-94
FUEL LINES	
DIESEL	

TABLE OF CONTENTS (Continued)

DESCRIPTION	PAGE
F (continued)	
⇒S/N F006A-3039	3-76
DIESEL 1004.4	
S/N F006A-3040⇔S/N F006A-10149	3-80
DIESEL 1004.42	
S/N F006A-10150⇒	3-84
FUEL SYSTEM	
DIESEL	
ALL	
⇒S/N F006A-7082	3-16
LPG	
⇒S/N F006A-7082	3-4
S/N F006A-7083⇒	3-8
S/N F006A-8489⇒	3-12
PETROL	
S/N F006A-7083⇒	3-20
FUEL TANK	
DIESEL	
S/N F006A-7083⇒	3-32
LPG	3-24
PETROL AND DIESEL	
⇒S/N F006A-7082	3-26
S/N F006A-7083⇒	3-30
FULL SUSPENSION SEAT	
SHEET 1 OF 2	1-8
SHEET 2 OF 2	1-10
G	
GAUGE CLUSTER	4-66
GOVERNOR	
LPG	
S/N F006A-8489⇒	3-38
H	
HAND PUMP	6-8
HEADER HOSE	
THREE STAGE FULL FREE-LIFT	11-36
TWO STAGE LIMITED FREE-LIFT	11-34
HEATER	
⇒S/N F006A-8488	11-10
S/N F006A-8489⇒	11-14
HOOD	1-12
HYDRAULIC OIL FILTER	8-24
HYDRAULIC PUMP	8-54
HYDRAULIC SYSTEM	
OIL CLUTCH	
⇒D/B 03/1998	8-2
POWERSHIFT	
⇒S/N F006A-10556	8-6
S/N F006A-10557⇒	8-10

TABLE OF CONTENTS (Continued)

DESCRIPTION	PAGE
H (continued)	
STEERING HYDRAULIC	
S/N F006A-10557⇒	8-14
TRANSMISSION COOLING	
S/N F006A-10557⇒	8-18
HYDRAULIC TANK	
⇒S/N F006A-10556.....	8-20
I	
IGNITION WIRE ROUTING KIT	4-12
INNER MAST	
THREE STAGE FULL FREE-LIFT	10-6
TWO STAGE LIMITED FREE-LIFT.....	9-4
INSTRUMENT PANEL	
⇒S/N F006A-3790.....	4-54
S/N F006A-3791⇔S/N F006A-7082.....	4-58
S/N F006A-7083⇒.....	4-62
INTERMEDIATE MAST	
THREE STAGE FULL FREE-LIFT	10-4
L	
LABELS	1-21
LIFT	
TWO STAGE LIMITED FREE-LIFT.....	9-6
LIFT CYLINDER	
FREE-LIFT	
THREE STAGE FULL FREE-LIFT	10-20
MAIN	
THREE STAGE FULL FREE-LIFT	10-16
TWO STAGE LIMITED FREE-LIFT.....	9-10
LIFT PUMP	
DIESEL 1004.4	
⇒S/N F006A-10149	3-96
DIESEL 1004.42	
S/N F006A-10150⇒.....	3-98
LIGHTS	
D/B 11/1998⇒	11-46
⇒S/N F006A-3790.....	11-40
S/N F006A-3791⇔D/B 11/1998	11-42
LOAD BACKREST EXTENSION.....	1-28
LPG CONVERTER	
⇒S/N F006A-7941.....	3-48
S/N F006A-7942⇔S/N F006A-9655.....	3-50
S/N F006A-9656⇒.....	3-52
M	
MAIN LIFT	
THREE STAGE FULL FREE-LIFT	10-8
MANIFOLD	
DIESEL 1004.4	

TABLE OF CONTENTS (Continued)

DESCRIPTION	PAGE
M (continued)	
S/N F006A-3040⇔S/N F006A-10149	2-190
DIESEL 1004.42	
S/N F006A-10150⇒	2-192
DIESEL 4.284.2	
⇒S/N F006A-3039	2-188
MASTER CYLINDER	7-20
MONOTROL PEDAL	5-52
MOTOR MOUNT	
⇒S/N F006A-7431	2-4
S/N F006A-7432⇒	2-6
N	
NON-SUSPENSION SEAT	1-6
O	
OIL FILTER	
DIESEL	
S/N F006A-3040⇒	2-140
DIESEL 4.248.2	
⇒S/N F006A-3039	2-138
OIL PUMP	
PETROL AND LPG	
1986 THRU 1993 SERIES MOTOR	2-126
1994 THRU 1995 SERIES MOTOR	2-128
1996 THRU 2001 SERIES MOTOR	2-130
2002 THRU 2004 SERIES ENGINE	2-132
OIL SUMP	
DIESEL 1004.4	
S/N F006A-3040⇔S/N F006A-10149	2-172
DIESEL 4.284.2	
S/N F006A-3039⇒	2-168
OIL SUMP AND PUMP	
DIESEL 1004.42	
S/N F006A-10150⇒	2-176
OUTER MAST	
THREE STAGE FULL FREE-LIFT	10-2
TWO STAGE LIMITED FREE-LIFT	9-2
OVERHEAD GUARD	1-24
P	
PARK BRAKE	7-2
PUMP ADAPTER	
DIESEL	
S/N F006A-10557⇒	6-24

TABLE OF CONTENTS (Continued)

DESCRIPTION	PAGE
S	
SEAT ASSEMBLY	1-2
SIDE-SHIFT CARRIAGE	
1524 MM	11-20
1981 MM	
THREE STAGE FULL FREE-LIFT	11-28
TWO STAGE LIMITED FREE-LIFT	11-24
SIDE-SHIFT CYLINDER	
1524 MM	11-32
STARTER MOTOR	
DIESEL	4-72
OPTIONAL	4-74
PETROL AND LPG	
⇒S/N F006A-8488	4-68
S/N F006A-8489⇒	4-70
STEERING COLUMN	
⇒S/N F006A-3039	6-2
S/N F006A-3040⇔S/N F006A-6480	6-4
S/N F006A-6481⇒	6-6
STEERING CYLINDER	6-30
STEERING HYDRAULIC	
HEAVY DUTY	8-22
STEERING PUMP	
HEAVY DUTY	6-26
⇒S/N F006A-10556	6-18
S/N F006A-10557⇒	6-22
STROBE LIGHT	
HIGH INTENSITY	11-52
INSTALLATION	11-49
MEDIUM INTENSITY	11-50
T	
THROTTLE BODY	
S/N F006A-7083⇒	3-44
THROTTLE LINKAGE	
⇒S/N F006A-7082	3-54
S/N F006A-7083⇒	3-56
THROTTLE PEDAL	
OIL CLUTCH AND POWERSHIFT WITH FORWARD/REVERSE LEVER	3-58
POWERSHIFT WITH MONOTROL PEDAL	3-60
TILT CYLINDER	8-56
TIMING GEAR	
DIESEL 1004.4	
S/N F006A-3040⇔S/N F006A-10149	2-164
DIESEL 1004.42	
S/N F006A-10150⇒	2-166
DIESEL 4.284.2	
⇒S/N F006A-3039	2-162
TIRE AND WHEEL	
DRIVE	11-58
STEERING	11-60
TORQUE CONVERTER	

TABLE OF CONTENTS (Continued)

DESCRIPTION	PAGE
T (continued)	
POWERSHIFT	5-38
TRAIL AXLE	
D/B 05/1999⇒	6-14
⇒D/B 05/1999	6-10
TRANSMISSION	
OIL CLUTCH	
⇒D/B 09/1997	5-4
POWERSHIFT	5-20
TRANSMISSION GEARS	
POWERSHIFT	
D/B 09/1997⇒	5-26
⇒D/B 09/1997	5-24
V	
VALVE COVER	
DIESEL 1004.4	
S/N F006A-3040⇔S/N F006A-10149	2-184
DIESEL 4.284.2	
⇒S/N F006A-1957, S/N F006A-3039⇒	2-180
⇒S/N F006A-3039, S/N F006A-1958⇒	2-182
VALVE COVER AND INLET MANIFOLD	
PETROL AND LPG	
1996 THRU 1999 SERIES ENGINE	2-90
2000 THRU 2004 SERIES ENGINE	2-94
4LM 1994 SERIES MOTOR	2-82
5LM 1995 SERIES MOTOR	2-86
VALVE COVER AND ROCKER ARM SHAFT	
DIESEL 1004.42	
S/N F006A-10150⇒	2-186
W	
WATER SEPARATOR	
DIESEL	
S/N F006A-10150⇒	3-100
WINDOW	
SHEET 1 OF 2	
S/N F006A-3758⇒	11-54
SHEET 2 OF 2	
S/N F006A-3758⇒	11-56
WIPER AND FAN	11-16
WIRE HARESS	
LPG ENGINE	
S/N F006A11426Y⇒	4-110
WIRE HARNESS	
DIESEL TIER II ENGINE	
S/N F006A-1612Y⇒	4-134
GOVERNOR	
S/N F006A-7083⇒	4-114
LPG ENGINE	

TABLE OF CONTENTS (Continued)

DESCRIPTION	PAGE
W (continued)	
S/N F006A8489⇔S/N F006A11425Y	4-108
LPG MOTOR	
S/N F006A-7083⇒	4-104
MAIN	
DIESEL	
D/B 10/1991⇒	4-100
PETROL AND LPG	
S/N F006A-7083⇒	4-98
NEUTRAL START	
FORWARD/REVERSE LEVER	
S/N F006A-7083⇒	4-112
MONOTROL PEDAL	
S/N F006A-7083⇒	4-96
PETROL	
ENGINE	
S/N F006A-10432⇒	4-132
PETROL THROTTLE BODY INJECTION	
S/N F006A-7083⇒	4-116
⇒S/N F006A-7083	4-120
SHEET 1 OF 2	
S/N F006A-8489⇔S/N F006A-10431	4-124
SHEET 2 OF 2	
S/N F006A-8489⇔S/N F006A-10431	4-128

SECTION 1
FRAME

DESCRIPTION	PAGE
COUNTERWEIGHT	1-26
COWL AND FLOOR PLATES	1-16
FULL SUSPENSION SEAT	
SHEET 1 OF 2	1-8
SHEET 2 OF 2	1-10
HOOD	1-12
LABELS	1-21
LOAD BACKREST EXTENSION	1-28
NON-SUSPENSION SEAT	1-6
OVERHEAD GUARD	1-24
SEAT ASSEMBLY	1-2

SEAT ASSEMBLY (Figure 1-1)

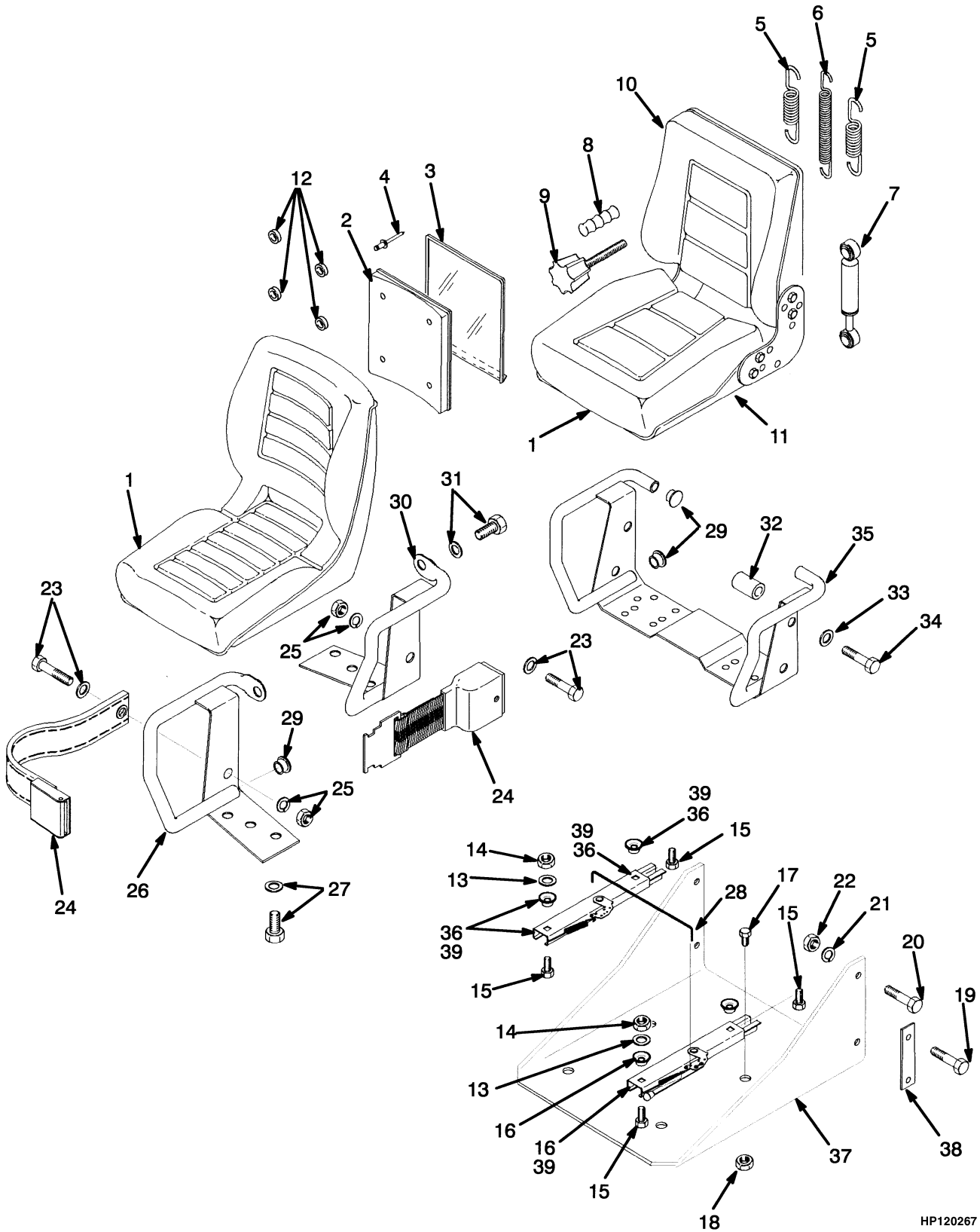

HP120267

SEAT ASSEMBLY**KEY:****A: Standard Seat****B: Suspension Seat**

ITEM	PART NO.	DESCRIPTION	QTY	
			A	B
1	377901	Seat (Vinyl Cover).....	1	..
1	377908	Seat (Fabric Cover).....	1	..
1	1345826	Seat	1
2	335988	Base (Information Case)	1	..
2	335989	Base (Information Case) (Information Case).....	..	1
3	335991	Cover (Information Case) (Information Case)	1	1
4	222029	Rivet	4	..
4	222030	Rivet	4
5	326364	Spring.....	..	2
6	326363	Spring.....	..	1
7	326978	Shock Absorber	1
8	326362	Knob	1
9	326365	Spindle (Adjuster).....	..	1
10	326361	Back Cushion (Vinyl)	1
11	326360	Seat Pan.....	..	1
12	1326337	Spacer.....	..	4
13	ad 221733	Washer	2	..
13	221733	Washer	4	..
14	15055	Nut	4
14	ad 145639	Nut	4
15	186261	Capscrew.....	..	4
15	18731	Capscrew.....	4	..
15	ad 364914	Capscrew.....	4	..
15	ad 18727	Capscrew.....	..	4
16	335553	Seat Rail	1	1
16	204114	Spacer	4	4
17	16836	Capscrew.....	4	4
18	145639	Nut	4	4
19	ad 292517	Capscrew.....	4	4
20	287854	Capscrew.....	4	4
21	292682	Lockwasher.....	4	4
22	136692	Nut	4	4
23	ad 379199	Capscrew.....	2	2
23	ad 379697	Washer	2	2
24	ad 1374750	Seat Belt	1	1
25	ad 379697	Washer	4	4
25	ad 379698	Nut	4	4
26	ad 364807	Hip Restraint (RH)	1	..
27	ad 18727	Capscrew.....	4	..
27	ad 18515	Washer	4	..
28	f 1300107	Rod	1	1
29	ad 364854	Plug	2	4
30	ad 364808	Hip Restraint (LH).....	1	..
31	ad 379197	Capscrew.....	2	..
31	ad 379198	Washer	2	..
32	ad 364848	Spacer	2

SEAT ASSEMBLY

ITEM	PART NO.	DESCRIPTION	QTY	
			A	B
33	ad 379675	Washer	2
34	ad 379674	Capscrew	2
35	ad 364847	Restraint	1
36	e 335556	Seat Rail	1	1
36	e 204114	Spacer	4	4
37	b 1358710	Seat Pan (With Cab)	1	1
37	c 1461088	Seat Pan (With Cab)	1	1
37	b 1358736	Seat Pan (Without Cab)	1	1
37	c 1461089	Seat Pan (Without Cab)	1	1
38	ad 385085	Spacer	2	2
39	f 383116	Seat Rail (RH)	1	1

FOOTNOTES:

- a** With Operator Restraint
- b** ⇒ S/N F006A-10431
- c** S/N F006A-10432 ⇒
- d** S/N F006A-1966 ⇒
- e** ⇒ S/N F006A-3202
- f** S/N F006A-3203 ⇒

NON-SUSPENSION SEAT (Figure 1-2)

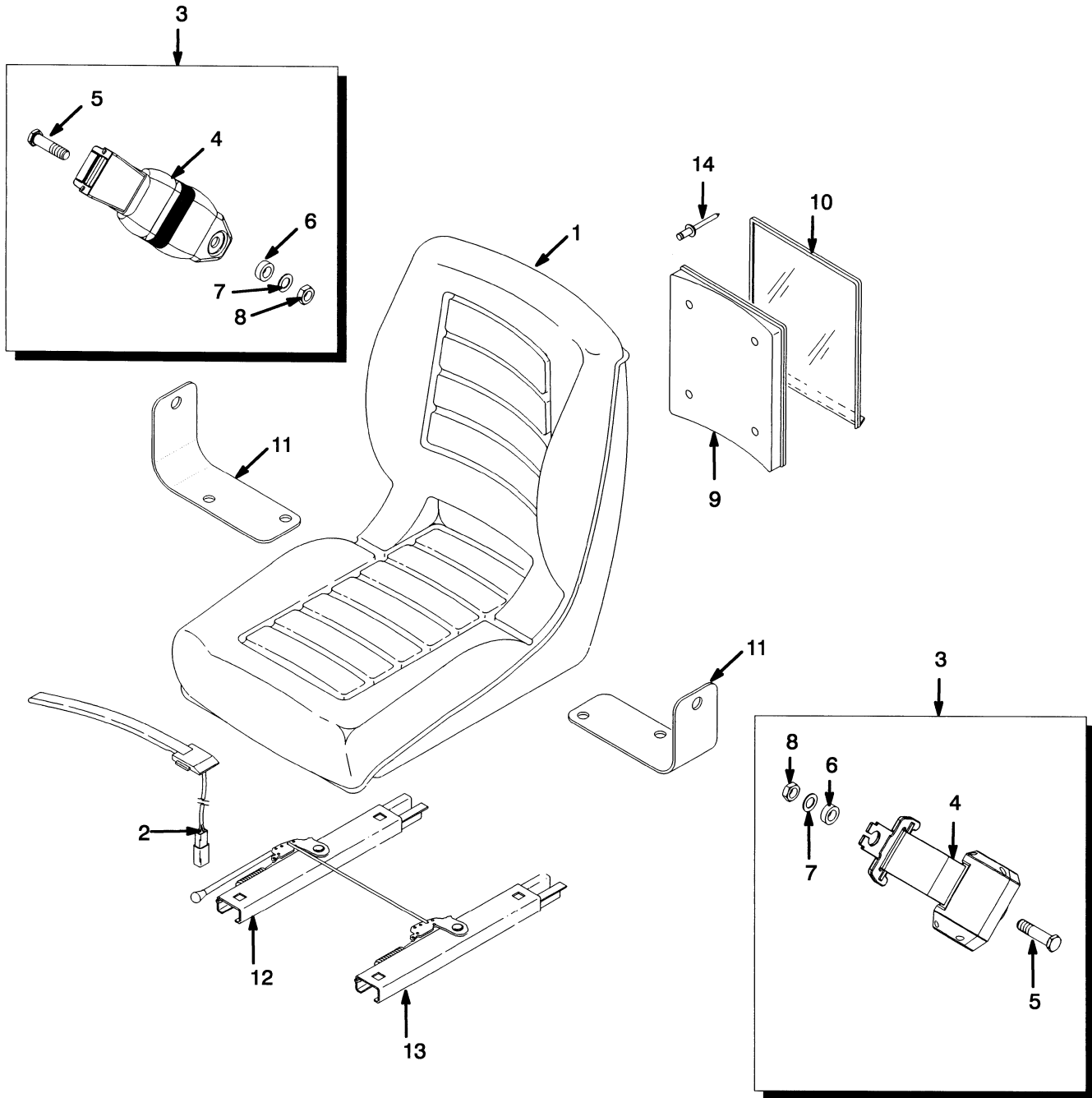

HP120268

NON-SUSPENSION SEAT

ITEM	PART NO.	DESCRIPTION	QTY
	1460231	Non-Suspension Seat.....	1
1	364911	Seat.....	1
2	2037311	Switch Assembly	1
3	1461081	Seat Belt Kit.....	1
4	Seat Belt	1
5	Screw	2
6	Washer.....	2
7	Washer.....	2
8	Nut	2
9	335988	Base (Information Case)	1
10	335991	Cover (Information Case).....	1
11	1470175	Bracket	1
12	1470176	Seat Rail.....	1
13	1470177	Seat Rail.....	1
14	878236	Spacer	4

FULL SUSPENSION SEAT (Figure 1-3) SHEET 1 OF 2

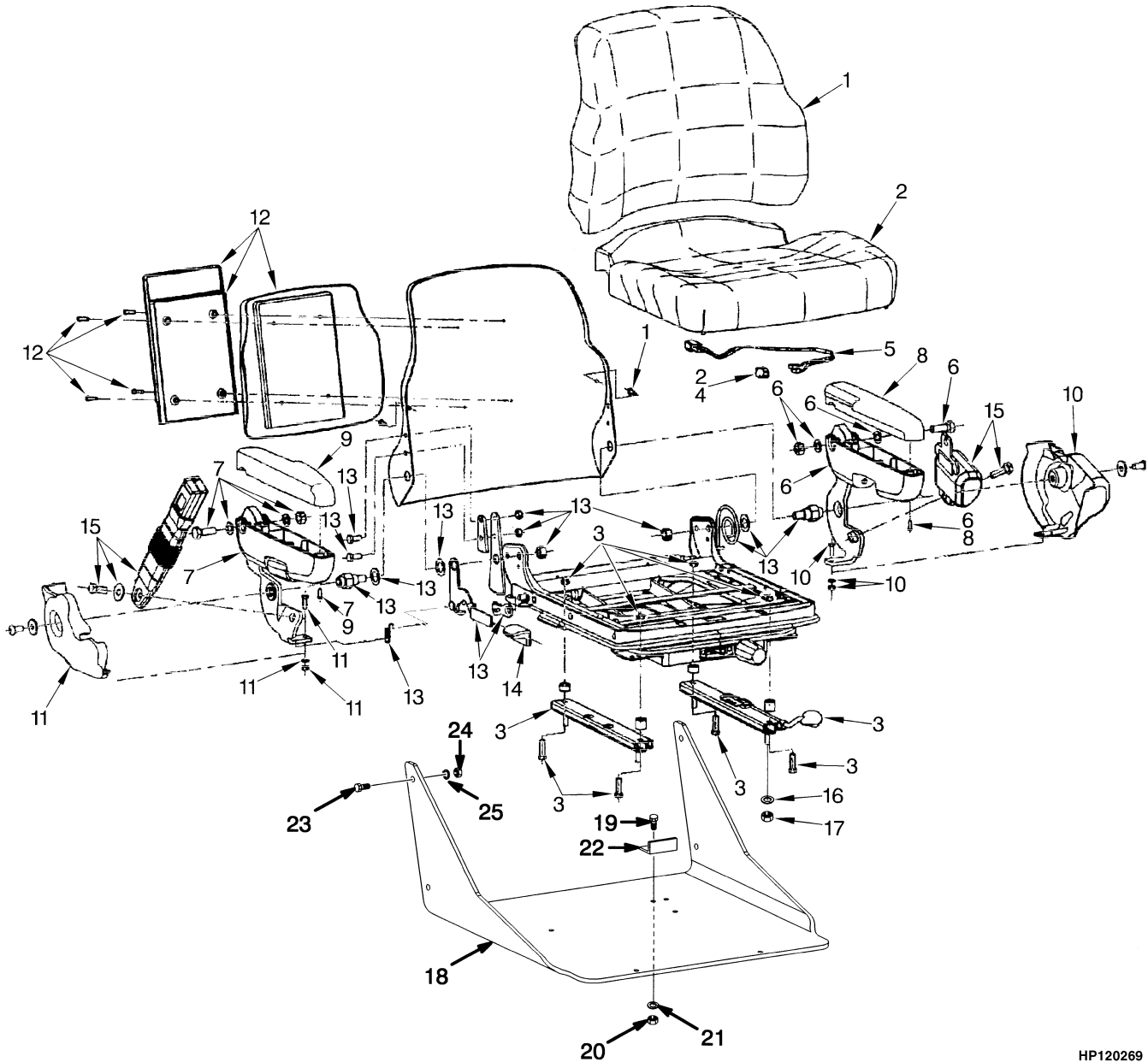

HP120269

**FULL SUSPENSION SEAT
SHEET 1 OF 2**

ITEM	PART NO.	DESCRIPTION	QTY
	1466006	Full Suspension Seat (Vinyl).....	1
	1466007	Full Suspension Seat (Fabric)	1
1	1467533	Back Cushion (Vinyl)	1
1	1467535	Back Cushion (Fabric)	1
2	1494076	Seat Cushion (Vinyl).....	1
2	1467536	Seat Cushion (Fabric)	1
3	1467513	Slider Kit	1
4	1467514	Switch.....	1
5	1467515	Wire Harness	1
6	1467516	Armrest (LH) (LH).....	1
7	1467517	Armrest (RH) (RH)	1
8	1467518	Cap (LH).....	1
9	1467519	Cap (RH)	1
10	1467520	Cover (LH)	1
11	1467521	Cover (RH)	1
12	1467522	Holder Kit.....	1
13	1467530	Recliner Kit.....	1
14	1467531	Recliner Knob.....	1
15	1467532	Seat Belt Kit.....	1
16	a 15175	Washer	6
16	b 15175	Washer	4
17	a 145639	Nut	6
17	b 145639	Nut	4
18	a 1478706	Seat Pan (With Cab)	1
18	b 1479677	Seat Pan (With Cab)	1
18	a 1478708	Seat Pan (With Overhead Guard)	1
18	b 1479678	Seat Pan (With Overhead Guard)	1
19	a 16836	Capscrew	2
20	145639	Nut.....	6
21	15175	Washer	6
22	a 1478807	Stop	1
23	287854	Capscrew	4
24	136692	Nut.....	4
25	292682	Lockwasher	4

FOOTNOTES:**a** ⇒ S/N F006A-10979X**b** S/N F006A-10980X ⇒

FULL SUSPENSION SEAT (Figure 1-4) SHEET 2 OF 2

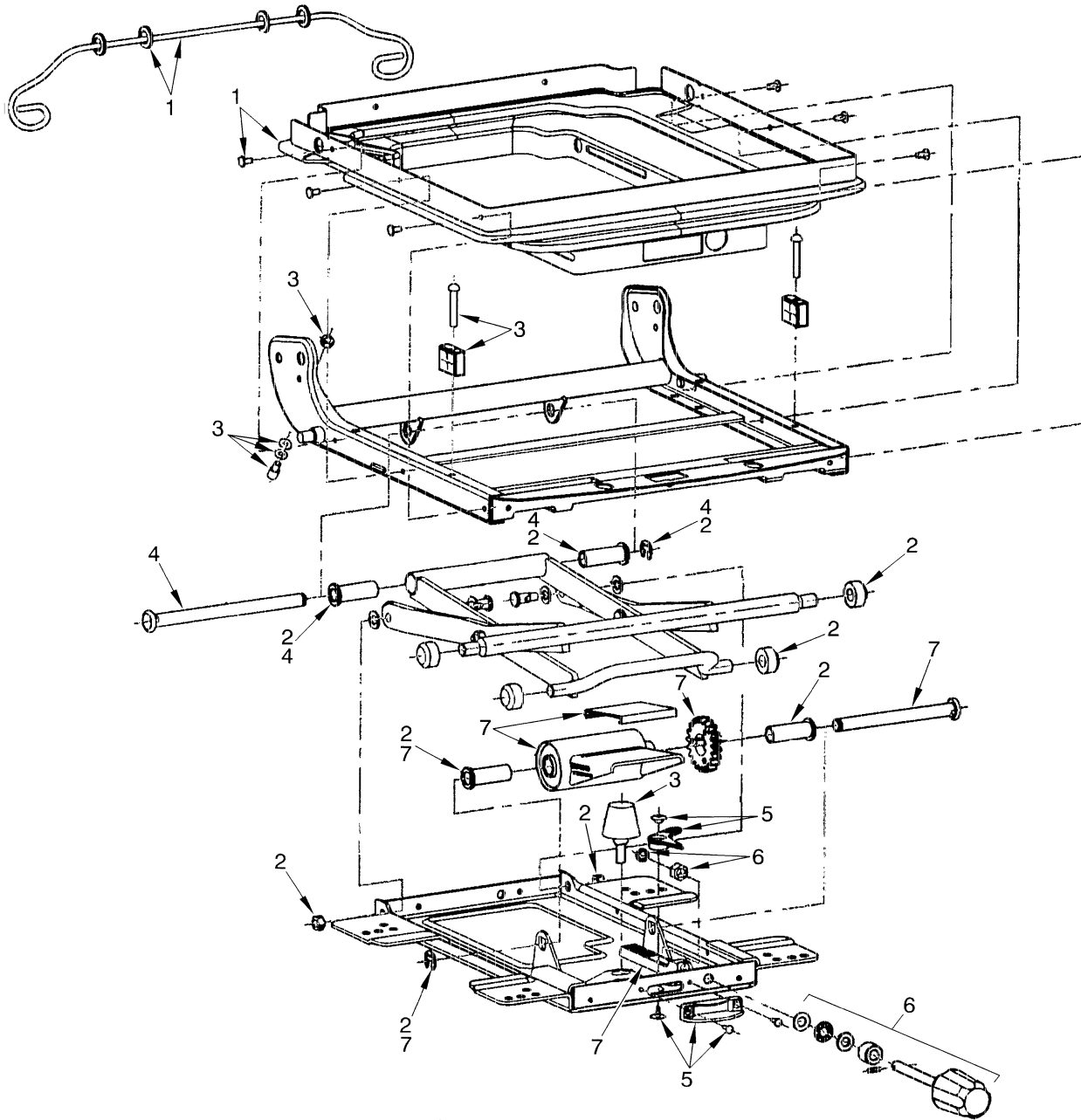

HP120270

**FULL SUSPENSION SEAT
SHEET 2 OF 2**

ITEM	PART NO.	DESCRIPTION	QTY
	1466006	Full Suspension Seat (Vinyl).....	1
	1466007	Full Suspension Seat (Fabric)	1
1	1467523	Boot Kit.....	1
2	1467524	Roller and Bearing Kit	1
3	1467525	Bumper and Stop Kit	1
4	1467526	Bearing Shaft Kit	1
5	1467527	Weight Adjuster Indicator Kit	1
6	1467528	Knob Kit.....	1
7	1467529	Suspension Spring Kit.....	1

HOOD (Figure 1-5)

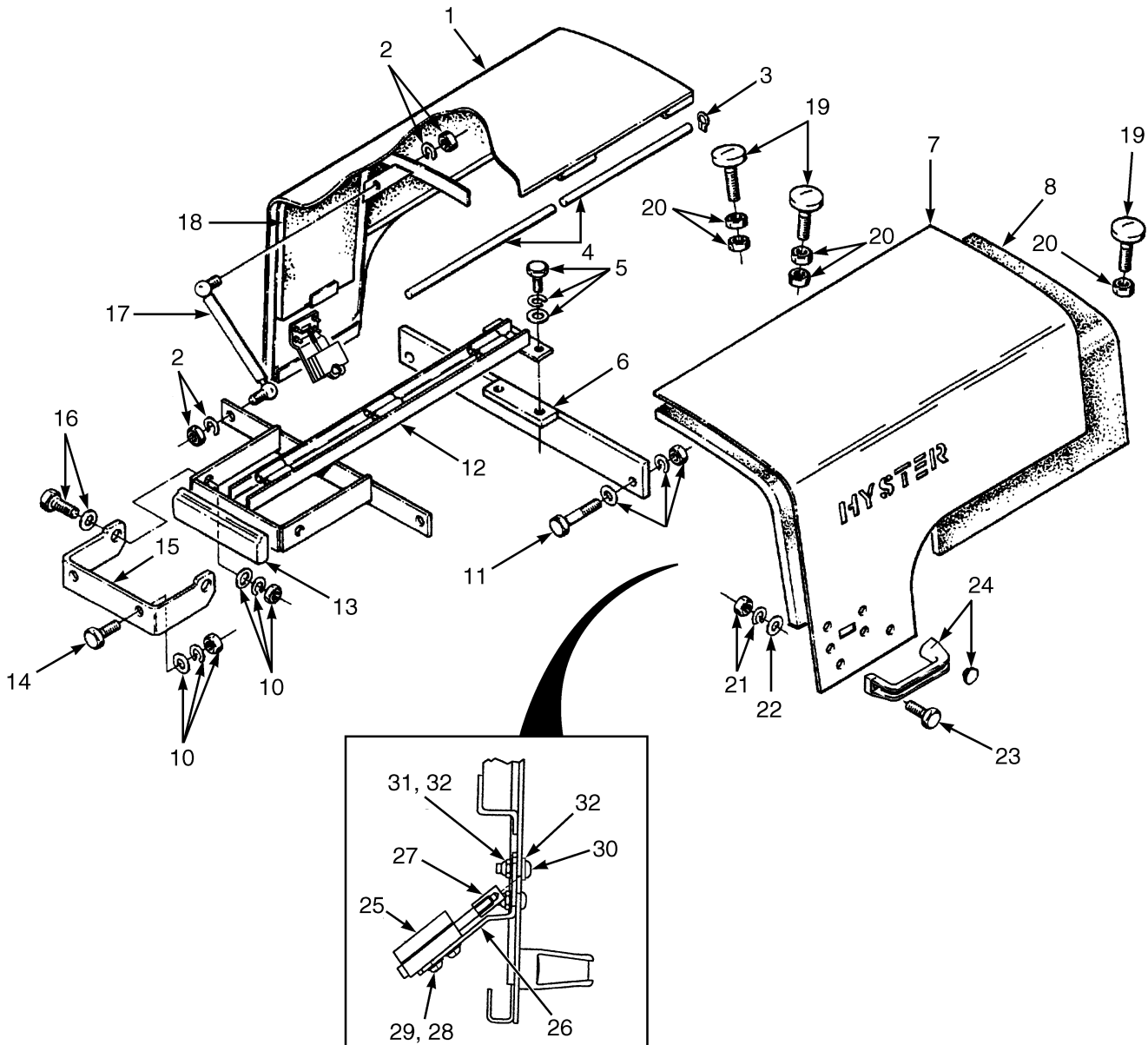

HP120271

HOOD**KEY:****A: Non-EEC****B: EEC**

ITEM	PART NO.	DESCRIPTION	QTY	
			A	B
1	367260	Hood (RH)	1	..
1	1392568	Hood (RH)	1
2	303117	Nut	4	4
2	292681	Lockwasher.....	4	4
3	367228	Ring	4	4
4	367227	Pin	2	2
5	136985	Capscrew.....	2	2
5	292682	Lockwasher.....	2	2
5	296421	Washer	2	2
6	367233	Crossmember	1	1
7	367246	Hood (LH)	1	..
7	1392566	Hood (LH)	1
8	377624	Liner.....	2	2
9	377622	Liner (LH).....	1	..
9	1392558	Liner (LH).....	..	1
10	136692	Nut	6	6
10	292682	Lockwasher.....	6	6
10	296421	Washer	6	6
11	292519	Capscrew.....	2	2
12	367235	Channel	1	1
13	261165	Tape	AR	AR
14	136985	Capscrew.....	2	2
15	a 367236	Bracket.....	1	1
15	b 377350	Bracket.....	1	1
16	a 136985	Capscrew.....	2	2
16	b 287860	Capscrew.....	2	2
16	296421	Washer	2	2
17	353021	Gas Spring.....	2	2
18	377623	Liner (RH)	1	..
18	1392560	Liner (RH)	1
19	367251	Stop Screw	6	4
20	15055	Nut	10	6
21	136687	Nut	4	4
21	292680	Lockwasher.....	4	4
22	320156	Washer	4	4
23	292501	Capscrew.....	4	4
24	362030	Handle	2	2
25	1377478	Latch	2
26	1392570	Plate	2
27	1392571	Knob	2
28	296161	Capscrew.....	..	8
29	292680	Lockwasher.....	..	8
30	296159	Capscrew.....	..	8

HOOD

ITEM	PART NO.	DESCRIPTION	QTY	
			A	B
31	316834	Nut	8
32	1476421	Washer	4

FOOTNOTES:

a ⇒ S/N F006A-3039

b S/N F006A-3040 ⇒

COWL AND FLOOR PLATES (Figure 1-6)

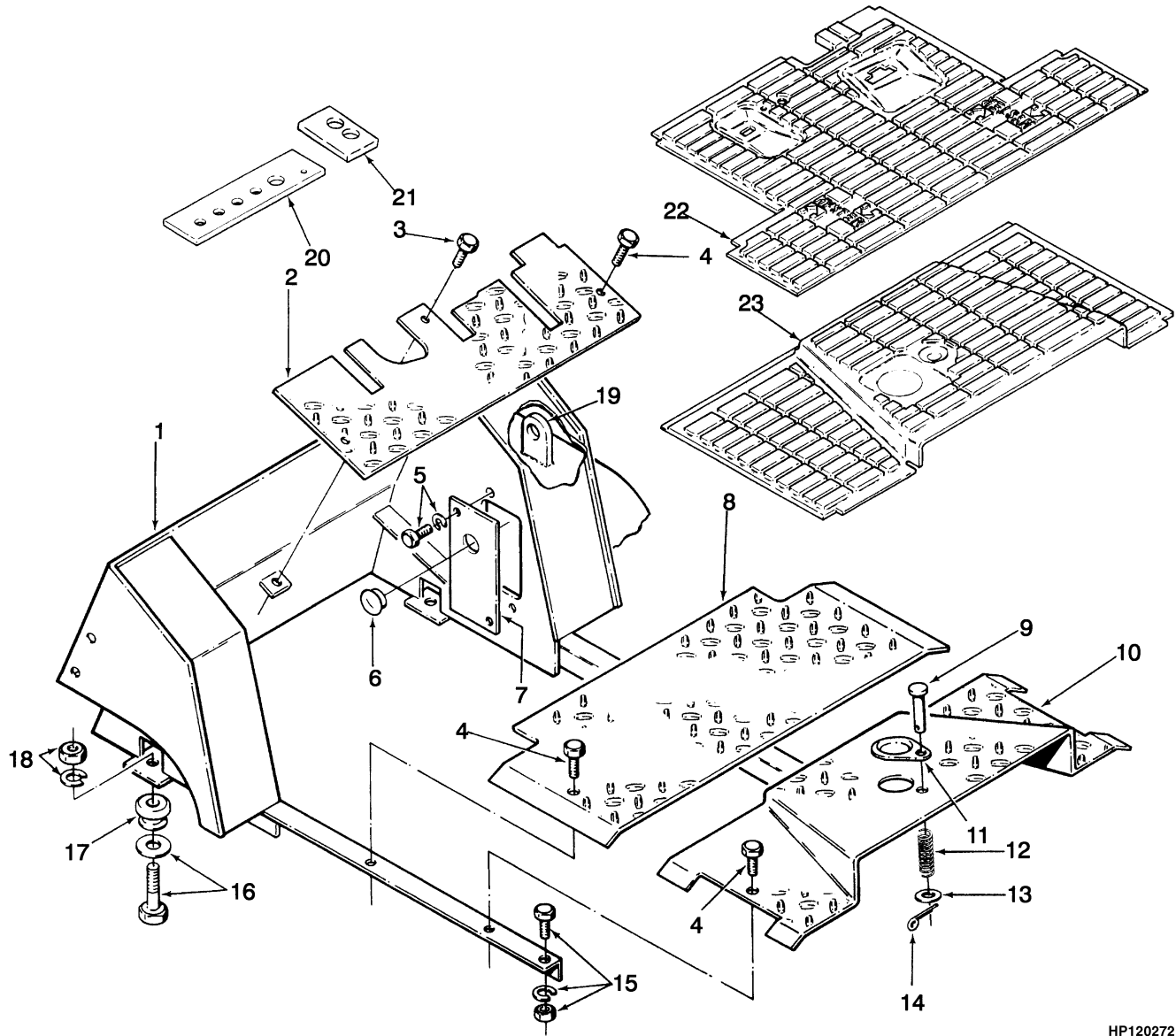

HP120272

COWL AND FLOOR PLATES**KEY:****A: Oil Clutch****B: Powershift**

ITEM	PART NO.	DESCRIPTION	QTY	
			A	B
1	e 344377	Cowl.....	1	1
1	f 1346710	Cowl.....	1	1
2	e 357312	Floorplate.....	1	1
2	f 1312724	Floorplate.....	1	1
3	329067	Screw.....	1	1
4	329067	Screw.....	6	6
5	136681	Capscrew.....	4	4
5	292681	Lockwasher.....	4	4
6	374002	Plug	2	2
7	342980	Plate	2	2
8	357276	Floorplate.....	1	1
9	b 177590	Rod End Pin	1
10	b 357269	Floorplate.....	1	..
10	a 370283	Floorplate.....	1	..
10	b 357273	Floorplate.....	..	1
10	a 369146	Floorplate.....	..	1
11	b 313815	Plate	1
12	a 137122	Spring	1
13	b 320157	Washer	2
14	b 15212	Cotter Pin.....	..	1
15	136985	Capscrew.....	2	2
15	292682	Lockwasher (LH).....	1	1
15	296361	Washer (RH).....	2	2
15	320156	Washer	2	2
15	136692	Nut.....	2	2
16	292533	Capscrew.....	2	2
16	300939	Washer	2	2
17	129962	Mount.....	2	2
18	216877	Nut.....	2	2
18	292683	Lockwasher.....	2	2
19	254113	Lifting Eye (Optional)	4	4
20	bc 370276	Seal	1	1
20	bd 1479752	Seal	1	1
21	a 370278	Seal	1	1
22	e 369528	Floormat (Front).....	1	1
22	f 1312722	Floormat (Front).....	1	1
23	b 374004	Floormat (Rear)	1	1
23	a 369525	Floormat (Rear)	1	1
24	340828	Running Board (RH)	1	..
24	304829	Carrier Assembly (LH)	1	..
	379409	Noise Reduction Kit (Includes Items 20-23)	1	1

FOOTNOTES:**a** With Cab**b** Without Cab

Thank you so much for reading.
Please click the “Buy Now!”
button below to download the
complete manual.



After you pay.

You can download the most
perfect and complete manual in
the world immediately.

Our support email:

ebooklibonline@outlook.com