

PARTS MANUAL

ELECTRIC

**E2.00-3.20XM
(F108)**

CUSTOMER EDITION

HYSTER

SECTIONS

1	FRAME
2	ELECTRICAL SYSTEM
3	DRIVE UNIT
4	STEERING SYSTEM
5	BRAKE/ACCELERATOR SYSTEM
6	HYDRAULIC SYSTEM
7	MAST-TWO STAGE LIMITED FREE-LIFT
8	MAST-THREE STAGE FULL FREE-LIFT
9	MAST-TWO STAGE FULL FREE-LIFT
10	OPTIONS
11	NUMERICAL INDEX

TABLE OF CONTENTS

DESCRIPTION	PAGE
A	
ACCELERATOR	5-14
ACCELERATOR PEDAL.....	5-16
AUXILIARY TUBES	
FOUR STAGE FULL FREE-LIFT	
FOUR FUNCTION GROUP	10-34
TWO AND THREE STAGE FULL FREE-LIFT	
FOUR FUNCTION GROUP	10-32
TWO STAGE LIMITED FREE-LIFT	
THREE FUNCTION GROUP	10-26
WITH ROTATOR	
TWO AND THREE STAGE FULL FREE-LIFT)(THREE FUNCTION GROUP	10-30
WITHOUT ROTATOR	
TWO AND THREE STAGE FULL FREE-LIFT)(THREE FUNCTION GROUP	10-28
B	
BACK-UP ALARM	10-44
BATTERY CONNECTOR	2-96
BRAKE	5-6
BRAKE AND BACK-UP LIGHTS	
⇒S/N F108A-04068W	10-36
S/N F108A-04069W⇒	10-38
BRAKE PEDAL LINKAGE	5-2
C	
CARRIAGE	
SIX ROLLER	
THREE STAGE FULL FREE-LIFT	
⇒S/N B508B-11567, ⇒S/N B563B-6155.....	8-26
S/N B508B-11568⇒, S/N B563B-6156⇒.....	8-28
TWO STAGE FULL FREE-LIFT	9-26
TWO STAGE LIMITED FREE-LIFT	7-16
CONTACTOR	
REGENERATIVE BRAKING AND FIELD WEAKENING	
⇒S/N F108A-04068	2-86
⇒S/N F108A-04068.....	2-84
S/N F108A-04069⇒.....	2-92
CONTACTOR PANEL	
CONTACTOR HYDRAULIC	
⇒S/N F108A-04068	2-62
SCR HYDRAULIC	
⇒S/N F108A-04068	2-52
SHEET 1 OF 2	
S/N F108A-04069⇒	2-70
SHEET 2 OF 2	
S/N F108A-04069⇒	2-72
TRANSISTOR HYDRAULIC	
WITH FIELD WEAKENING	
S/N F108A-02746⇔S/N F108A-04068 EXC. 2753, 2755, 2776-2777	2-68
WITHOUT FIELD WEAKENING	
S/N F108A-02746⇔S/N F108A-04068 EXC. 2753, 2755, 2776-2777	2-66

TABLE OF CONTENTS (Continued)

DESCRIPTION	PAGE
C (continued)	
CONTROL PANEL	
72/80 VOLT	
⇒S/N F108A-04068	2-78
CONTACTOR HYDRAULIC	
S/N F108A-04069⇒	2-64
TRANSISTOR HYDRAULIC	
S/N F108A-04069⇒	2-60
CONTROL VALVE	
FOUR FUNCTION	6-50
THREE FUNCTION	6-46
CONTROL VALVE ATTACHING PARTS	6-36
COUNTERWEIGHT	1-26
COVERS	
D/B 10/1999⇒	1-18
⇒D/B 10/1999	1-14
CYLINDER	
E2.00-2.50XM	
TWO STAGE LIMITED FREE-LIFT	7-9
E3.00-3.20XM	
TWO STAGE LIMITED FREE-LIFT	
⇒S/N B562B-16062	7-11
S/N B562B-16063⇒	7-13
D	
DASH DISPLAY	
D/B 04/1999⇒	2-26
PREMIUM	
TRANSISTOR CONTROLLER	
⇒D/B 04/1999	2-24
DIRECTION CONTACTOR	
⇒S/N F108A-04068.....	2-82
DRIVE AXLE	3-2
DRIVE MOTOR MOUNT	6-6
DRIVE TIRE AND WHEEL	10-4
DRIVE, REAR LIGHTS, AND SPOTLIGHT	10-42
E	
ELECTRICAL	
CONTACTOR HYDRAULIC STANDARD LIFT TRUCK	
PERFORMANCE TRUCK WITH CONTACTOR PUMP	
S/N F108A-04069⇒	2-8
COWL	2-20
SCR HYDRAULIC	
ENERGY SAVER PERFORMANCE TRUCK WITH SCR PUMP	
⇒S/N F108A-04068	2-4
TRANSISTOR HYDRAULIC STANDARD LIFT TRUCK	
PERFORMANCE TRUCK WITH TRANSISTOR CONTROLLER	
S/N F108V-5948⇔S/N F108A-04068	2-16
ELECTRICAL SYSTEM	

TABLE OF CONTENTS (Continued)

DESCRIPTION	PAGE
E (continued)	
CONTACTOR AND TRANSISTOR HYDRAULIC S/N F108A-04069⇒	2-12
EMERGENCY POWER/SEAT SWITCH BYPASS.....	10-50
F	
FORKS	
E2.00-2.50XM	1-42
E3.00-3.20XM	1-44
FRAME	
D/B 10/1999⇒	1-10
⇒D/B 10/1999	1-6
FREE-LIFT	
E2.00-2.50XM	
THREE STAGE FULL FREE-LIFT	8-14
TWO STAGE FULL FREE-LIFT	9-8
E3.00-3.20XM	
THREE STAGE FULL FREE-LIFT	8-18
TWO STAGE FULL FREE-LIFT	9-12
FREE-LIFT CYLINDER	
THREE STAGE FULL FREE-LIFT	8-24
TWO STAGE FULL FREE-LIFT	9-23
FULL SUSPENSION SEAT	
SHEET 1 OF 2	
D/B 12/2000⇒	1-38
SHEET 2 OF 2	
D/B 12/2000⇒	1-40
G	
GEAR PUMP	
⇒D/B 06/1997	4-16
D/B 6/1⇒ S/N F108A03258V	4-18
OPTIONAL.....	4-22
S/N F108A-03259V⇒	4-20
H	
HAND LEVER	
D/B 10/2001⇒	6-44
⇒D/B 10/2001	6-40
HAND PUMP	
⇒S/N F108A-03258V	4-6
S/N F108A-03259V⇒	4-8
HEADER HOSE	
THREE STAGE FULL FREE-LIFT	8-30
TWO STAGE FULL FREE-LIFT	9-28
TWO STAGE LIMITED FREE-LIFT.....	7-18
HOOD.....	1-28
HOOD LATCH	1-32
HYDRAULIC.....	6-2
HYDRAULIC MOTOR.....	6-26

TABLE OF CONTENTS (Continued)

DESCRIPTION	PAGE
H (continued)	
HIGH SPEED	
WITH BWI	6-24
OPTIONAL	
SHEET 1 OF 2	6-28
SHEET 2 OF 2	6-30
HYDRAULIC PUMP.....	6-20
12 CC	
ENERGY SAVER	
⇒D/B 04/1998	6-10
SINGLE GEAR PUMP	
D/B 04/1998⇒	6-12
19 CC	
DOUBLE GEAR PUMP	
D/B 04/1998⇒	6-16
19 CC PUMP	
OPTIONAL	6-18
19 CC SINGLE GEAR	
OPTIONAL	6-22
OPTIONAL.....	6-14
HYDRAULIC TANK.....	6-54
I	
INNER MAST	
THREE STAGE FULL FREE-LIFT	8-8
TWO STAGE FULL FREE-LIFT	9-4
TWO STAGE LIMITED FREE-LIFT.....	7-4
INSTRUMENT CLUSTER	
STANDARD LIFT TRUCK	
⇒S/N F108A-04068	2-22
INTEGRAL SIDE-SHIFT CARRIAGE	
THREE STAGE FULL FREE-LIFT	10-20
TWO STAGE FULL FREE-LIFT	10-18
TWO STAGE LIMITED FREE-LIFT.....	10-16
INTEGRAL SIDE-SHIFT CYLINDER	10-22
INTEGRAL SIDE-SHIFT HYDRAULIC HOSES	
TWO AND THREE STAGE FULL FREE-LIFT	10-25
TWO STAGE LIMITED FREE-LIFT.....	10-24
INTERMEDIATE MAST	
THREE STAGE FULL FREE-LIFT	8-4
L	
LABELS AND PAINT	1-3
LIFT	
TWO STAGE LIMITED FREE-LIFT.....	7-6
LINE CONTACTOR	
S/N F108A-04069⇒.....	2-94
LOAD BACKREST EXTENSION.....	1-46

TABLE OF CONTENTS (Continued)

DESCRIPTION	PAGE
M	
MAIN CYLINDER	
LEFT HAND	
TWO STAGE FULL FREE-LIFT	
⇒S/N B509A-2090Z, ⇒S/N B564A-2046Z	9-15
S/N B509A-2091Z⇒, S/N B564A-2047Z⇒	9-17
RIGHT HAND	
TWO STAGE FULL FREE-LIFT	
⇒S/N B509A-2090Z, ⇒S/N B564A-2046Z	9-19
S/N B509A-2091Z⇒, S/N B564A-2047Z⇒	9-21
THREE STAGE FULL FREE-LIFT	8-21
MAIN LIFT	
THREE STAGE FULL FREE-LIFT	8-10
TWO STAGE FULL FREE-LIFT	9-6
MAST INSTALLATION	6-32
MASTER CYLINDER	5-4
N	
NON-SUSPENSION SEAT	
SEARS	1-34
O	
OUTER	
TWO STAGE FULL FREE-LIFT	9-2
TWO STAGE LIMITED FREE-LIFT	7-2
OUTER MAST	
THREE STAGE FULL FREE-LIFT	8-2
OVERHEAD GUARD	
⇒S/N F108A-2962	1-22
S/N F108A-2963⇒	1-24
P	
PANEL ASSEMBLY	
CONTACTOR HYDRAULIC	
⇒S/N F108A-04068	2-48
SCR HYDRAULIC	
⇒S/N F108A-04068	2-50
TRANSISTOR HYDRAULIC	
S/N PENDING PER ECN 59798-04⇒S/N F108A-04068	2-58
PARK BRAKE	
LEVER-ACTUATED	
⇒S/N F108A-02745	5-8
S/N F108A-02746⇒	5-10
PUMP CONTACTOR	
S/N F108A-04069⇒	2-90
S	
SCR CONTROLLER	
⇒S/N F108A-02745 INC. 2753, 2755, 2776-2777	2-74
SEMI-SUSPENSION SEAT	1-36
SHIFT LEVER	2-28

TABLE OF CONTENTS (Continued)

DESCRIPTION	PAGE
S (continued)	
SIDE-SHIFT CARRIAGE	
⇒S/N B507B-16123, ⇒S/N B508B-36393, ⇒S/N B509B-04068, ⇒S/N B562B-11879, ⇒S/N B563B-19083, ⇒S/N B564B-033320.....	10-6
S/N B507B-16124⇒, S/N B508B-36394⇒, S/N B509B-04069⇒, S/N B562B-11880⇒, S/N B563B-19084⇒, S/N B564B-03321⇒.....	10-10
SIDE-SHIFT CYLINDER.....	10-14
STEER TIRE AND WHEEL.....	10-2
STEERING AXLE	
⇒S/N F108A-04788X.....	4-40
S/N F108A-04789X⇒.....	4-44
STEERING CONTACTOR	
⇒S/N F108A-04068.....	2-88
STEERING CYLINDER.....	4-13
STEERING HYDRAULIC.....	4-10
STEERING MOTOR	
STANDARD	
WITHOUT BWI	
⇒S/N F108A-03422.....	4-24
S/N F108A-3423V⇔S/N F108A-05066V.....	4-26
S/N F108A05067⇔S/N F108A05748A.....	4-28
S/N F108A05749A⇒.....	4-30
WITH BWI	
ENERGY SAVER PERFORMANCE TRUCK	
⇒S/N F108A-03422.....	4-32
S/N F108A-03423⇔S/N F108A-05066.....	4-34
S/N F108A05067⇔S/N F108A05748A.....	4-36
S/N F108A05749A⇒.....	4-38
STEERING POD.....	4-2
STROBE LIGHT.....	10-48
T	
TILT CYLINDER.....	6-34
TRACTION MOTOR	
⇒D/B 02/1998.....	3-12
PERFORMANCE TRUCK	
D/B 02/1998⇔S/N F108A-04068W.....	3-14
STANDARD LIFT TRUCK	
ENERGY SAVER	
⇒S/N F108A-4068W.....	3-10
WITH BWI	
S/N F108A-04068W⇒.....	3-16
TRANSISTOR ASSEMBLY	
⇒S/N F108A-04068.....	2-80
TRANSISTOR CONTROL PANEL	
CONTACTOR HYDRAULIC	
⇒S/N F108A-04068.....	2-54
TRANSMISSION AND DIFFERENTIAL.....	3-6

TABLE OF CONTENTS (Continued)

DESCRIPTION	PAGE
W	
WIRE HARNESS	
CONTACTOR HYDRAULIC	
⇒S/N F108A-04068	2-39
STANDARD LIFT TRUCK	
⇒S/N F108A-04068	2-32
CONTROL VALVE SWITCH	
S/N F108A-04069⇒	2-46
DASH	2-34
FORWARD/REVERSE	2-30
LIGHT	
⇒S/N F108A-04068	2-36
S/N F108A-04069⇒	2-37
LIGHTS	
⇒S/N F108A-04068W	10-45
S/N F108A-04069W⇒	10-46
MAIN	
FULL TIME POWER STEERING	
D/B 04/1997⇒	2-45
POWER STEERING ON-DEMAND	
D/B 04/1997⇒ S/N F108A04068W	2-44
⇒S/N F108A-04068	2-41
S/N F108A-04069⇒	2-42
PERFORMANCE TRUCK WITH CONTACTOR PUMP	
⇒S/N F108A-04068	2-33
SCR HYDRAULIC	
⇒S/N F108A-04068	2-40
SCR PUMP	
ENERGY SAVER PERFORMANCE TRUCK	
⇒S/N F108A-04068	2-31
STEERING MOTOR	
⇒S/N PENDING PER ECN 59798-04	2-38
SWITCH	
S/N F108A-2213⇒	10-47
WITH TRANSISTOR CONTROL	
⇒S/N F108A-04068	2-35

SECTION 1
FRAME

DESCRIPTION	PAGE
COUNTERWEIGHT	1-26
COVERS	
D/B 10/1999⇒	1-18
⇒D/B 10/1999	1-14
FORKS	
E2.00-2.50XM	1-42
E3.00-3.20XM	1-44
FRAME	
D/B 10/1999⇒	1-10
⇒D/B 10/1999	1-6
FULL SUSPENSION SEAT	
SHEET 1 OF 2	
D/B 12/2000⇒	1-38
SHEET 2 OF 2	
D/B 12/2000⇒	1-40
HOOD	1-28
HOOD LATCH	1-32
LABELS AND PAINT	1-3
LOAD BACKREST EXTENSION	1-46
NON-SUSPENSION SEAT	
SEARS	1-34
OVERHEAD GUARD	
⇒S/N F108A-2962	1-22
S/N F108A-2963⇒	1-24
SEMI-SUSPENSION SEAT	1-36

LABELS AND PAINT (Figure 1-1)

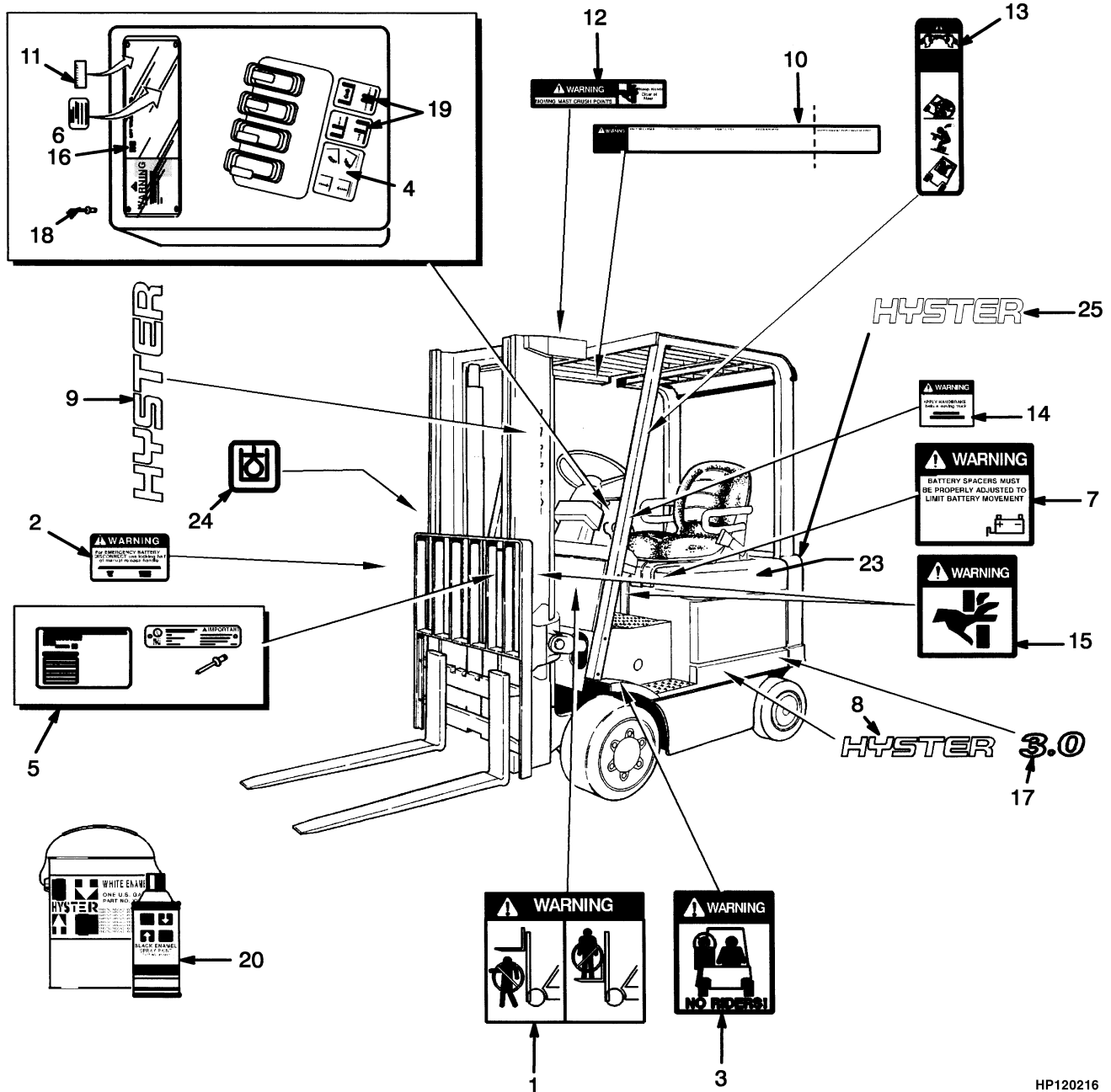

HP120216

LABELS AND PAINT

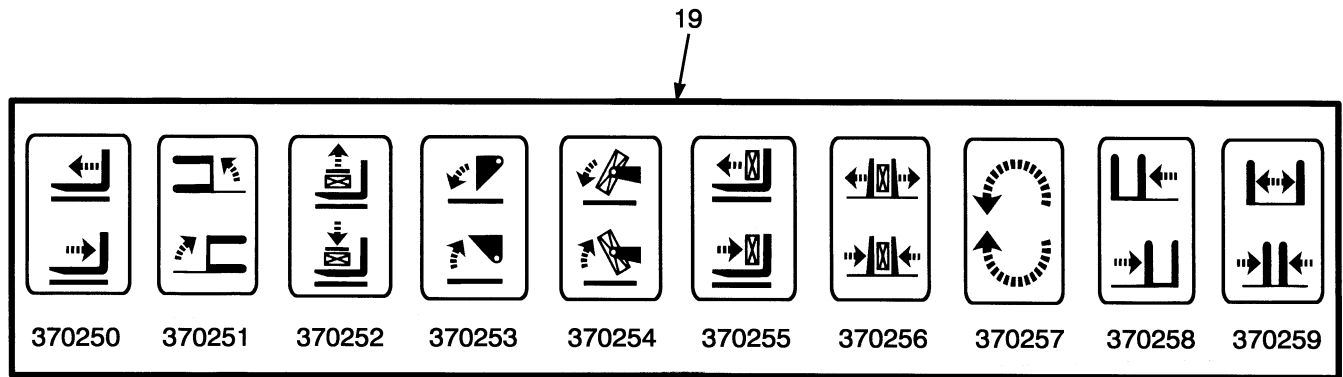

HP120066

ITEM	PART NO.	DESCRIPTION	QTY
1	1339830	Label (Mast Warning)	2
2	1342698	Label (Battery Disconnect)	1
3	1339828	Label (No Riders)	2
4	369573	Label (Lift/Tilt).....	1
5	320037	Label (Patent Plate).....	1
6	a	Nameplate	1
7	1342699	Label (Battery Spacer).....	1
8	1339674	Label (Hyster)	2
9	1339672	Label (Hyster)	2
10	1335140	Label (Operator Warning).....	1
11	1335138	Nameplate Tag (Notice To User).....	1
12	1343276	Label (Mast Warning)	1
13	1335143	Label (Tip Over Warning)	2
14	d 1357001	Label (Park Brake Warning).....	1
14	c 2310911	Label (Parking Brake Warning).....	1
15	1339832	Label (Pinch Point)	3
16	389687	Nameplate Cover	1
17	1339667	Label (Model 2.00).....	2
17	1339668	Label (Model 2.50).....	2
17	1339669	Label (Model 3.00).....	2
17	1339670	Label (Model 3.20).....	2
18	1380584	Rivet.....	4
19	370250	Label (Auxiliary Function - Reach)	1
19	370251	Label (Auxiliary Function - Swing)	1
19	370252	Label (Auxiliary Function - Stabilizer)	1
19	370253	Label (Auxiliary Function - Dump/Scoop)	1
19	370254	Label (Auxiliary Function - Upender)	1
19	370255	Label (Auxiliary Function - Push/Pull).....	1
19	370256	Label (Auxiliary Function - Clamp)	1
19	370257	Label (Auxiliary Function - Rotate)	1
19	370258	Label (Auxiliary Function - Side-Shift)	1
19	370259	Label (Auxiliary Function - Fork Spreader)	1
20	1345808	Paint (Yellow) (One Gallon).....	AR
20	1345809	Paint (Yellow) (Spray).....	AR
21	316844	Paint (Red) (Spray)	AR
22	1344901	Paint (Low Gloss Black) (Spray)	AR
22	1344902	Paint (Low Gloss Black) (One Gallon)	AR
23	1379808	Label (Hood Latch)	1

LABELS AND PAINT

ITEM	PART NO.	DESCRIPTION	QTY
24	1385099	Label (Hydraulic Oil Fill).....	1
25	b 893523	Label (Hyster) (Counterweight).....	1

FOOTNOTES:

- a** Contact your Local Hyster Dealer
- b** Optional
- c** With Park Brake Alarm
- d** Without Parking Brake Alarm

FRAME (Figure 1-2) (⇒D/B 10/1999)

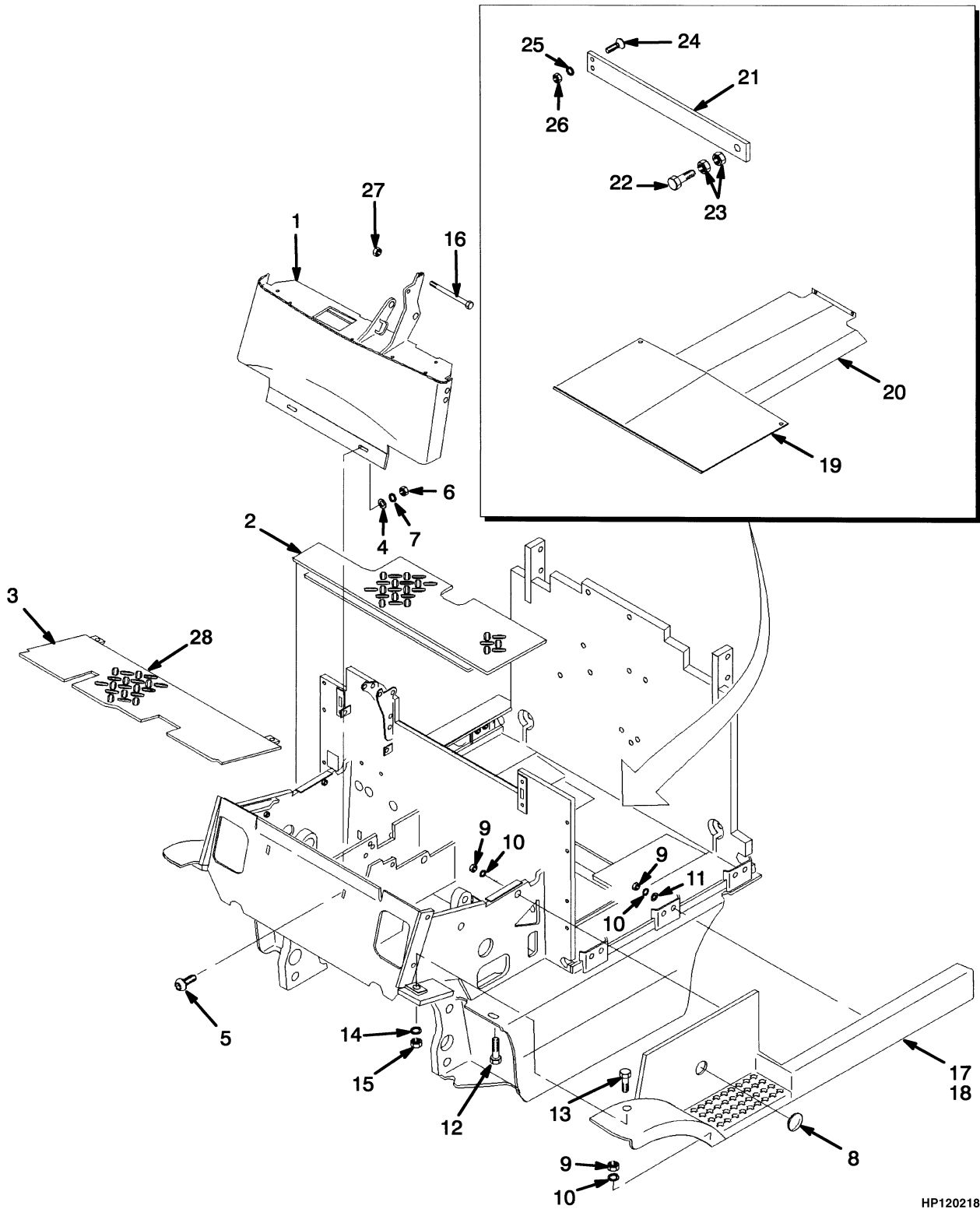

HP120218

FRAME
(⇒D/B 10/1999)**KEY:****A: 700 mm Battery Compartment****B: 847 mm Battery Compartment****C: 1015 mm Battery Compartment**

ITEM	PART NO.	DESCRIPTION	QTY		
			A	B	C
1	h 1340178	Cowl.....	1	1	1
1	c 1452068	Cowl.....	1	1	1
1	d 1460339	Cowl.....	1	1	1
1	1465530	Cowl.....	1	1	1
2	f 1453240	Wire Harness.....	1	1	1
2	g 1457085	Floorplate.....	1	1	1
3	f 1388456	Floorplate.....	1	1	1
3	g 1457081	Floorplate.....	1	1	1
4	15176	Washer	8	8	8
5	17105	Bolt	2	2	2
6	15056	Nut	2	2	2
7	15156	Lockwasher.....	2	2	2
8	1356377	Plug	2	2	2
9	g 136692	Nut	10	10	10
9	f 136692	Nut	12	12	12
10	g 292682	Lockwasher.....	10	10	10
10	f 292682	Lockwasher.....	12	12	12
11	86936	Washer	6	6	6
12	136985	Capscrew.....	2	2	2
13	292529	Capscrew.....	2	2	2
14	292683	Lockwasher.....	2	2	2
15	216877	Nut	2	2	2
16	18494	Capscrew.....	1	1	1
17	1340071	Fender (LH)	1
17	1340072	Fender (LH)	1	..
17	b 1362192	Fender (LH)	1
17	b 1362193	Fender (LH)	1	..
17	b 1362194	Fender (LH)	1
17	1362255	Fender (LH)	1
18	1340211	Fender (RH).....	1
18	1340212	Fender (RH).....	..	1	..
18	b 1362195	Fender (RH).....	1
18	b 1362196	Fender (RH).....	..	1	..
18	b 1362197	Fender (RH).....	1
18	1362254	Fender (RH).....	1
19	ae 1340222	Cover	1	..
19	ae 1340224	Cover	1
19	ae 2023868	Cover	1
20	325521	Cover	1	1	1
21	i 1340262	Plate	1	1	1
21	j 2023978	Plate	1	1	1
22	292584	Capscrew.....	1	1	1
23	296136	Nut	2	2	2
24	296227	Capscrew.....	2	2	2
25	292681	Lockwasher.....	2	2	2
26	239503	Nut	2	2	2

FRAME (⇒D/B 10/1999)

ITEM	PART NO.	DESCRIPTION	QTY		
			A	B	C
27	169874	Nut.....	1	1	1
28	895970	Floormat	1	1	1

FOOTNOTES:

- a** Optional
- b** Wide Track
- c** D/B 11/1997 ⇒ S/N F108A04068W
- d** S/N F108A04069W ⇒
- e** D/B 01/1997 ⇒
- f** ⇒ D/B 02/1998
- g** D/B 02/1998 ⇒
- h** ⇒ D/B 04/1997
- i** ⇒ D/B 09/1996
- j** D/B 09/1996 ⇒

FRAME (Figure 1-3) (D/B 10/1999⇒)

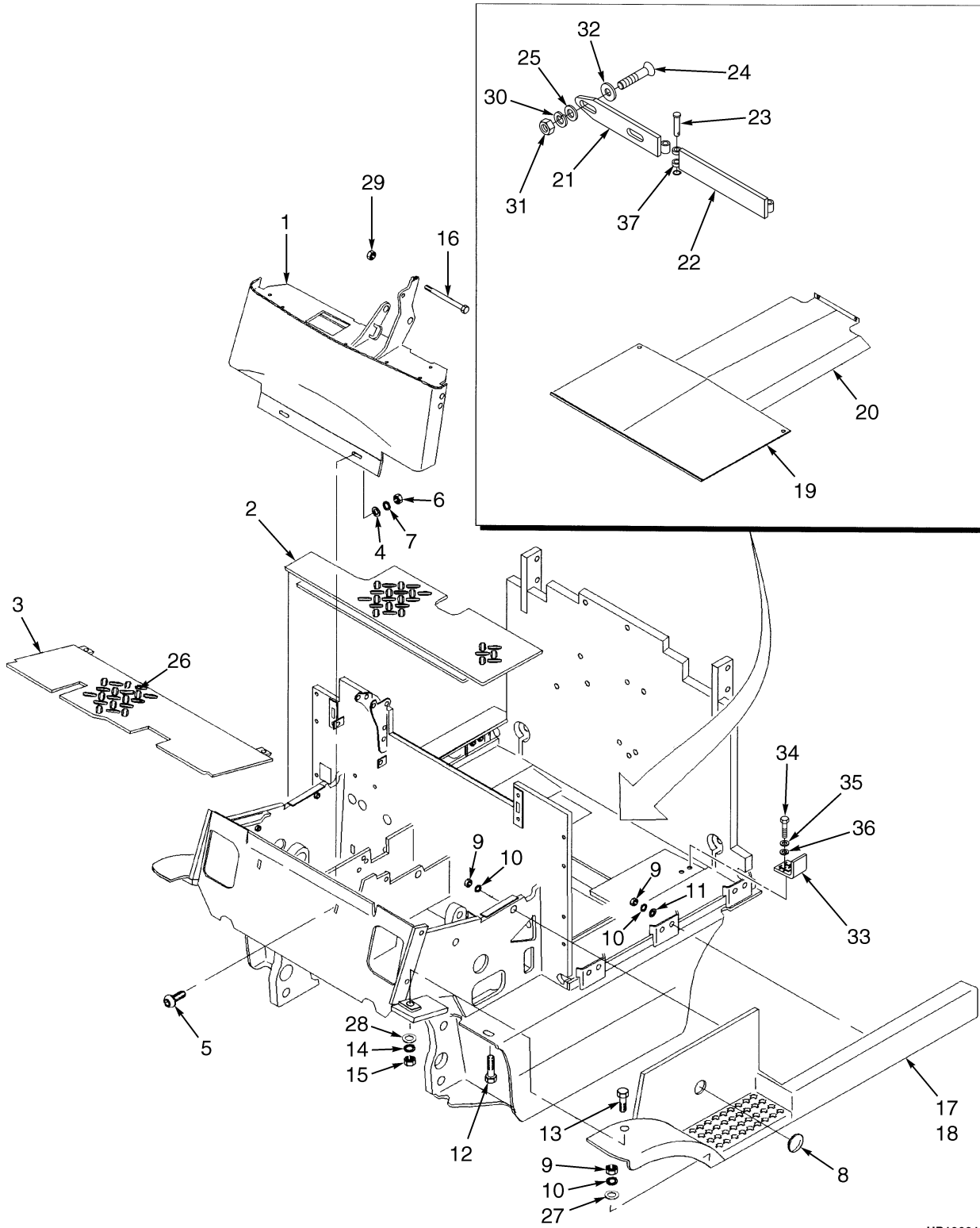

HP120219

FRAME
(D/B 10/1999⇒)**KEY:****A: 700 mm Battery Compartment****B: 847 mm Battery Compartment****C: 1015 mm Battery Compartment**

ITEM	PART NO.	DESCRIPTION	QTY		
			A	B	C
1	1465530	Cowl.....	1	1	1
2	1388456	Floorplate.....	1	1	1
3	1453420	Floorplate.....	1	1	1
4	15176	Washer	4	4	4
5	17105	Bolt	2	2	2
6	15056	Nut	2	2	2
7	15156	Lockwasher.....	2	2	2
8	1350231	Plug	2	2	2
9	136692	Nut	12	12	12
10	292682	Lockwasher.....	12	12	12
11	86936	Washer	6	6	6
12	136985	Capscrew.....	2	2	2
13	292529	Capscrew.....	2	2	2
14	292683	Lockwasher.....	2	2	2
15	216877	Nut	2	2	2
16	18494	Capscrew.....	1	1	1
17	1340071	Fender (LH)	1
17	1340072	Fender (LH)	1	..
17	a 1362192	Fender (LH)	1
17	a 1362193	Fender (LH)	1	..
17	a 1362194	Fender (LH)	1
17	1362255	Fender (LH)	1
18	1340211	Fender (RH).....	1
18	1340212	Fender (RH).....	..	1	..
18	a 1362195	Fender (RH).....	1
18	a 1362196	Fender (RH).....	..	1	..
18	a 1362197	Fender (RH).....	1
18	1362254	Fender (RH).....	1
19	1340220	Cover	1
19	1340222	Cover	1	..
19	1340224	Cover	1
20	325521	Cover	1	1	1
21	1493955	Plate	1	1	1
22	1493957	Plate	1	1	1
23	1509942	Pin	2	2	2
24	296249	Capscrew.....	2	2	2
25	296421	Washer	2	2	2
26	895970	Floormat	1	1	1
27	320160	Washer	2	2	2
28	320162	Washer	2	2	2
29	169874	Nut	1	1	1
30	292682	Lockwasher.....	2	2	2
31	136692	Nut	2	2	2
32	361973	Spacer	16	16	16
33	b 1483375	Spacer	2	2	2
34	b 136681	Capscrew.....	4	4	4

FRAME (D/B 10/1999⇒)

ITEM	PART NO.	DESCRIPTION	QTY		
			A	B	C
35	b 320158	Washer	4	4	4
36	b 292681	Lockwasher.....	4	4	4
37	58951	Snap Ring.....	2	2	2

FOOTNOTES:

- a** Wide Track
- b** With Battery Rollers

COVERS (Figure 1-4) (⇒D/B 10/1999)

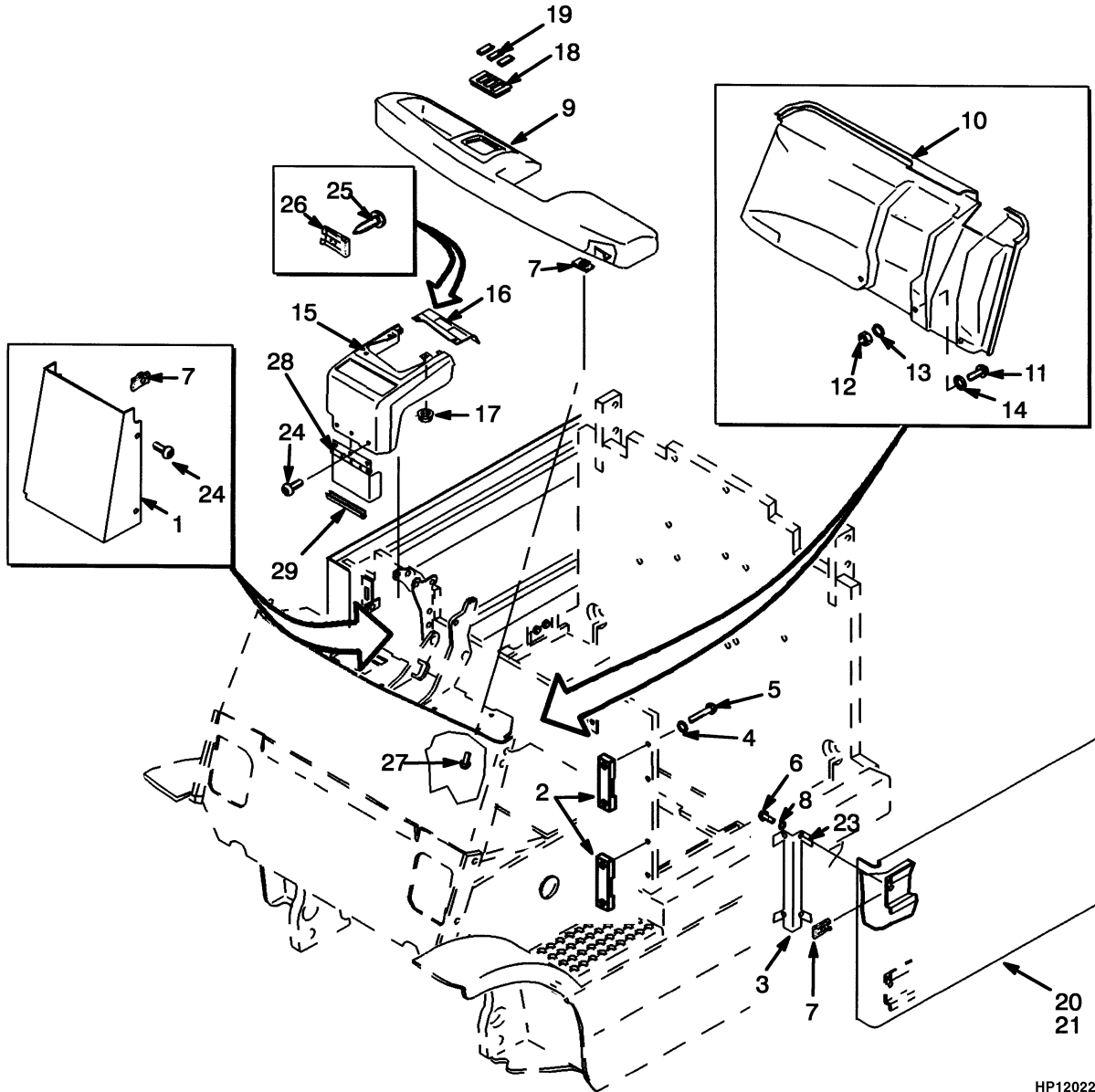

HP120220

COVERS
(⇒D/B 10/1999)**KEY:****A: 700 mm Battery Compartment****B: 847 mm Battery Compartment****C: 1015 mm Battery Compartment**

ITEM	PART NO.	DESCRIPTION	QTY		
			A	B	C
1	1340683	Plate	1	1	1
2	1340218	Catch	4	4	4
3	1377667	Plate	4	4	4
4	296360	Washer	8	8	8
5	296166	Capscrew.....	8	8	8
6	296159	Capscrew.....	10	10	10
7	1354323	Nut (Foldover).....	23	23	23
8	292680	Lockwasher.....	8	8	8
9	c 1339086	Dash	1	1	1
9	d 1460633	Dash	1	1	1
9	e 1465533	Dash	1	1	1
10	a 1339088	Liner.....	1	1	1
10	bi 1390322	Liner.....	1	1	1
10	h 1460397	Liner.....	1	1	1
11	296167	Capscrew.....	2	2	2
12	239503	Nut	2	2	2
13	292681	Lockwasher.....	2	2	2
14	a 1300117	Washer	2	2	2
14	bi 320158	Washer	2	2	2
15	1381909	Cover	1	1	1
16	1381910	Cover	1	1	1
17	169874	Nut	3	3	3
18	g 1382311	Mounting Panel (End).....	2	2	2
18	g 1382312	Mounting Panel (Center).....	1	1	1
18	f 376947	Bezel.....	1	1	1
19	g 1382313	Cover (With Lights).....	2	2	2
19	g 1382313	Cover (Without Lights).....	3	3	3
19	f 376949	Cover (With Lights).....	2	2	2
19	f 376949	Cover (Without Lights).....	3	3	3
20	1340618	Cover (LH)	1
20	1340619	Cover (LH)	1	..
20	1362252	Cover (LH)	1
21	j 1340621	Cover (RH).....	1
21	j 1340622	Cover (RH).....	..	1	..
21	j 1340648	Cover (RH).....	1
21	k 1390229	Cover (RH).....	1
21	k 1390230	Cover (RH).....	..	1	..
21	k 1390231	Cover (RH).....	1
22	1340868	Knob	1	1	1
23	15127	Washer	8	8	8
24	296161	Capscrew.....	3	3	3
25	1381919	Screw.....	2	2	2
26	1381918	Nut	2	2	2
27	353144	Capscrew.....	7	7	7

COVERS (⇒D/B 10/1999)

ITEM	PART NO.	DESCRIPTION	QTY		
			A	B	C
28	1364395	Cover	1	1	1
29	1376812	Trim.....	1	1	1

FOOTNOTES:

- a** ⇒ S/N F108A-02962U
- b** S/N F108A-02963U⇔S/N F108A-4068W
- c** ⇒ S/N F108A-03251V
- d** S/N F108A-03252V⇔S/N F108A-04504X
- e** S/N F108A-04505X ⇒
- f** ⇒ S/N F108A-2212
- g** S/N F108A-2213 ⇒
- h** S/N F108A-4069W ⇒
- i** S/N PENDING PER ECN 70317⇔S/N PENDING PER ECN 72804-10
- j** ⇒ D/B 07/1996
- k** D/B 07/1996 ⇒

NOTES

COVERS (Figure 1-5) (D/B 10/1999⇒)

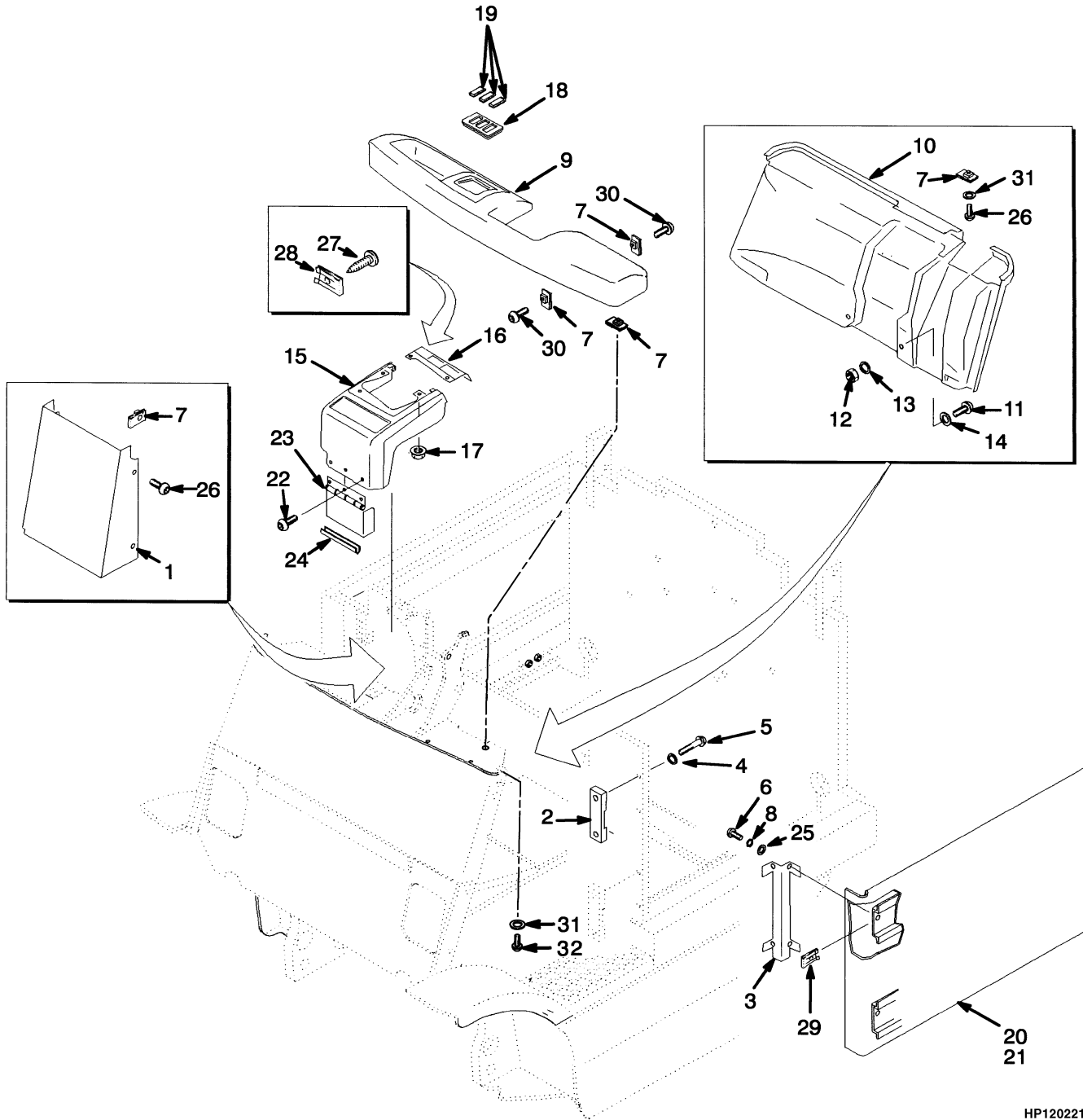

HP120221

COVERS
(D/B 10/1999⇒)**KEY:****A: 700 mm Battery Compartment****B: 847 mm Battery Compartment****C: 1015 mm Battery Compartment**

ITEM	PART NO.	DESCRIPTION	QTY		
			A	B	C
1	1388314	Cover	1	1	1
2	ab 1340218	Catch	4	4	4
3	ab 1377667	Plate	4	4	4
3	ac 1377667	Plate	2	2	2
4	ab 296360	Washer	8	8	8
5	ab 296165	Capscrew.....	8	8	8
6	ab 296159	Capscrew.....	10	10	10
6	ac 296159	Capscrew.....	4	4	4
7	b 325182	Nut	13	13	13
7	c 325182	Nut	14	14	14
7	1354323	Nut (Foldover) (Optional)	14	14	14
8	ab 292680	Lockwasher.....	8	8	8
8	ac 292680	Lockwasher.....	4	4	4
9	1465533	Dash	1	1	1
10	1460397	Liner.....	1	1	1
11	296167	Capscrew.....	2	2	2
12	239503	Nut	2	2	2
13	b 292681	Lockwasher.....	2	2	2
14	320158	Washer	2	2	2
15	1381909	Cover	1	1	1
16	1381910	Cover	1	1	1
17	b 169874	Nut	3	3	3
17	c 169874	Nut	4	4	4
18	1382311	Mounting Panel (End).....	2	2	2
18	1382312	Mounting Panel (Center).....	1	1	1
19	1382313	Cover (With Lights).....	2	2	2
19	1382313	Cover (Without Lights).....	3	3	3
20	ab 1340618	Cover (LH)	1
20	ac 1488447	Cover (LH)	1
20	ab 1340619	Cover (LH)	1	..
20	ac 1488448	Cover (LH)	1	..
20	ab 1362252	Cover (LH)	1
20	ac 1488449	Cover (LH)	1
21	ab 1390229	Cover (RH).....	1
21	ac 1488451	Cover (RH).....	1
21	ab 1390230	Cover (RH).....	..	1	..
21	ac 1488452	Cover (RH).....	..	1	..
21	ab 1390231	Cover (RH).....	1
21	ac 1488453	Cover (RH).....	1
22	1364399	Screw.....	3	3	3
23	1364395	Cover	1	1	1
24	1376812	Trim.....	1	1	1
25	ab 197068	Washer	8	8	8
25	ac 197068	Washer	4	4	4
26	b 296160	Capscrew.....	6	6	6
26	c 296160	Capscrew.....	7	7	7

COVERS (D/B 10/1999⇒)

ITEM	PART NO.	DESCRIPTION	QTY		
			A	B	C
27	1381919	Screw.....	2	2	2
28	1381918	Nut.....	2	2	2
29	ab 325182	Nut.....	8	8	8
29	ac 325182	Nut.....	4	4	4
30	353144	Capscrew.....	7	7	7
31	b 15127	Washer.....	3	3	3
31	c 15127	Washer.....	4	4	4
32	296161	Capscrew.....	4	4	4

FOOTNOTES:

- a** With Side Cover
- b** ⇒ D/B 10/2000
- c** D/B 10/2000 ⇒

OVERHEAD GUARD (Figure 1-6) (⇒S/N F108A-2962)

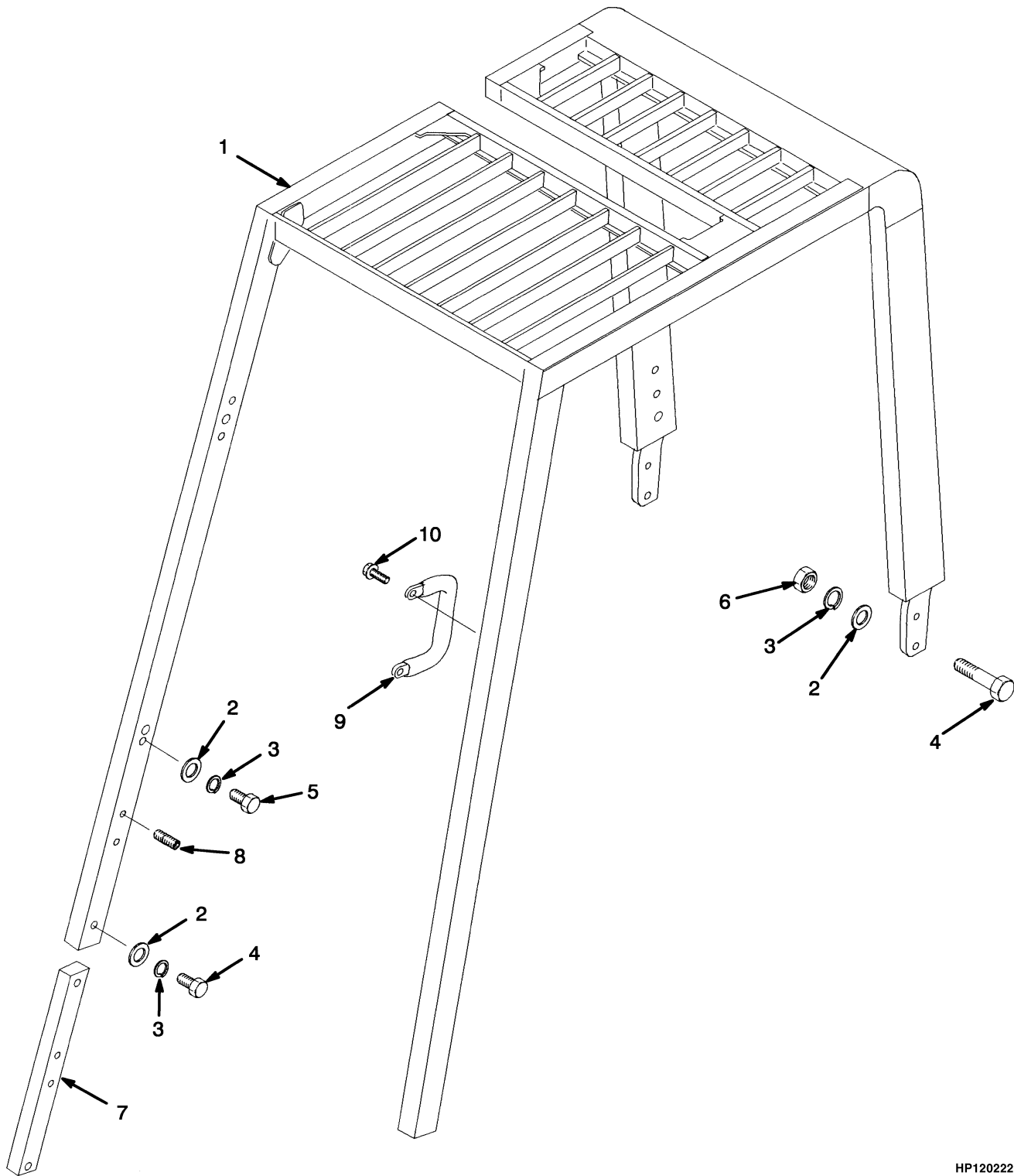

HP120222

OVERHEAD GUARD
(⇒S/N F108A-2962)**KEY:****A: Standard Height****B: Raised Height**

ITEM	PART NO.	DESCRIPTION	QTY	
			A	B
1	c 1340440	Overhead Guard	1	..
1	b 1340441	Overhead Guard	1	..
1	c 1340556	Overhead Guard	1
1	b 1340557	Overhead Guard	1
1	a 1340816	Overhead Guard	1	..
1	a 1340817	Overhead Guard	1
2	320161	Washer	10	10
3	292683	Lockwasher	10	10
4	293649	Capscrew	8	8
5	293647	Capscrew	2	2
6	300937	Locknut	4	4
7	1340321	Bar	2	2
8	302220	Screw	2	2
9	1343647	Handle	1	1
10	329067	Screw	2	2

FOOTNOTES:

- a** 1015 mm Battery Compartment
- b** 700 mm Battery Compartment
- c** 847 mm Battery Compartment

Thank you so much for reading.
Please click the “Buy Now!”
button below to download the
complete manual.



After you pay.

You can download the most
perfect and complete manual in
the world immediately.

Our support email:

ebooklibonline@outlook.com