

# **PARTS MANUAL**

---

## **ELECTRIC**

**E1.50-1.75XM, E2.00XMS  
(D114)**

CUSTOMER EDITION

---

# ***HYSTER***

**SECTIONS**

<b>1</b>	<b>FRAME</b>
<b>2</b>	<b>ELECTRICAL SYSTEM</b>
<b>3</b>	<b>DRIVE UNIT</b>
<b>4</b>	<b>STEERING SYSTEM</b>
<b>5</b>	<b>BRAKE/ACCELERATOR SYSTEM</b>
<b>6</b>	<b>HYDRAULIC SYSTEM</b>
<b>7</b>	<b>MAST-TWO STAGE LIMITED FREE-LIFT</b>
<b>8</b>	<b>MAST-THREE STAGE FULL FREE-LIFT</b>
<b>9</b>	<b>MAST-TWO STAGE FULL FREE-LIFT</b>
<b>10</b>	<b>OPTIONS</b>
<b>11</b>	<b>NUMERICAL INDEX</b>

**TABLE OF CONTENTS**

DESCRIPTION	PAGE
<b>A</b>	
ACCELERATOR .....	5-14
ACCELERATOR PEDAL.....	5-16
AUXILIARY TUBES	
TWO AND THREE STAGE FULL FREE-LIFT	
FOUR FUNCTION GROUP .....	10-24
<b>B</b>	
BACK-UP ALARM .....	10-36
BATTERY CONNECTOR	
TYPE SBE CONNECTOR .....	2-76
BRAKE AND BACK-UP LIGHTS	
12 VOLT	
S/N D114A-3842⇒ INC. 3719, 3837 .....	10-28
⇒S/N D114V-3841 EXC. 3719, 3837 .....	10-26
BRAKE ASSEMBLY	
⇒S/N D114A-01846U.....	5-6
S/N D114A-01847U⇒.....	5-8
BRAKE PEDAL LINKAGE .....	5-2
<b>C</b>	
CARRIAGE	
THREE STAGE FULL FREE-LIFT .....	8-18
TWO STAGE FULL FREE-LIFT .....	9-20
TWO STAGE LIMITED FREE-LIFT.....	7-12
CONTACTOR	
1:00:00 AM	
⇒S/N D114A-02865W .....	2-64
⇒S/N D114A-02865W.....	2-66
SHEET 1 OF 2	
S/N D114A-02866W⇒ .....	2-72
SHEET 2 OF 2	
⇒S/N D114A-02866W .....	2-74
CONTACTOR PANEL	
⇒S/N D114A-02865W.....	2-54
SHEET 1 OF 2	
S/N D114A-02866W⇒ .....	2-56
SHEET 2 OF 2	
S/N D114A-02866W⇒ .....	2-58
CONTROL VALVE	
FOUR FUNCTION .....	6-66
THREE FUNCTION .....	6-62
CONTROL VALVE ATTACHING PARTS.....	6-52
COUNTERWEIGHT .....	1-18
COVERS .....	1-10
<b>D</b>	
DASH DISPLAY	
ENERGY SAVER, PREMIUM, TRANSISTOR CONTROLLER	
D/B 04/1999⇒.....	2-21
⇒D/B 04/1999.....	2-20

## TABLE OF CONTENTS (Continued)

DESCRIPTION	PAGE
<b>D (continued)</b>	
DIFFERENTIAL .....	3-8
DIRECTION CONTACTOR	
⇒S/N D114A-02865W .....	2-62
DRIVE AXLE .....	3-2
DRIVE MOTOR MOUNT	
⇒S/N D114A-05030A .....	6-10
S/N D114A-05031A⇒ .....	6-12
<b>E</b>	
ELECTRICAL	
CONTACTOR HYDRAULIC	
⇒S/N D114A-02865W .....	2-10
S/N D114A-02866W⇒ .....	2-14
COWL .....	2-18
TRANSISTOR HYDRAULIC	
⇒S/N D114A-02865W .....	2-3
S/N D114A-02866W⇒ .....	2-6
<b>F</b>	
FORKS .....	1-34
FRAME .....	1-6
FREE-LIFT	
THREE STAGE FULL FREE-LIFT .....	8-10
TWO STAGE FULL FREE-LIFT .....	9-8
FREE-LIFT CYLINDER	
THREE STAGE FULL FREE-LIFT .....	8-16
TWO STAGE FULL FREE-LIFT .....	9-18
<b>G</b>	
GEAR PUMP	
⇒D/B 11/1997 .....	4-18
D/B 12/1997⇒ .....	4-20
OPTIONAL .....	4-22
GEARBOX AND DIFFERENTIAL .....	3-4
<b>H</b>	
HAND LEVER	
D/B 10/2001⇒ .....	6-60
⇒D/B 10/2001 .....	6-56
HEADER HOSE .....	9-22, 8-20 7-14
HOOD .....	1-20
HYDRAULIC	
⇒S/N D114A-05030A .....	6-4
S/N D114A-05031A⇒ .....	6-8
HYDRAULIC MOTOR	
CLOSED CONSTRUCTION	
D/B 11/2001⇒ .....	6-44
ECONOMY TRUCK WITHOUT BRUSH WEAR INDICATORS	
D/B 01/2000⇒ .....	6-30

**TABLE OF CONTENTS (Continued)**

DESCRIPTION	PAGE
H (continued)	
⇒D/B 01/2000.....	6-28
ENERGY SAVER TRUCK WITH BRUSH WEAR INDICATORS AND VENTED COVER OPTIONAL	
⇒D/B 11/2001.....	6-36
ENERGY SAVER TRUCK WITH OR WITHOUT BRUSH WEAR INDICATORS	
D/B 01/2000⇒.....	6-34
⇒D/B 01/2000.....	6-32
OPEN CONSTRUCTION	
D/B 11/2001⇒.....	6-38
PERFORMANCE TRUCK.....	6-40
PREMIUM TRUCK WITH BRUSH WEAR INDICATORS AND SOLID COVERS OPTIONAL	
⇒D/B 11/2001.....	6-42
S/N D114A-05031A⇒.....	6-46
HYDRAULIC PUMP	
12 CC	
SINGLE GEAR PUMP	
D/B 08/1998⇔S/N D114A-05030A.....	6-16
19 CC	
DOUBLE GEAR PUMP	
D/B 08/1998⇔S/N D114A-05030A.....	6-20
19 CC PUMP	
OPTIONAL	
⇒S/N D114A-05030A.....	6-22
19 CC PUMP - LOW NOISE	
S/N D114A-05031A⇒.....	6-23
OPTIONAL	
⇒S/N D114-05030A.....	6-18
⇒S/N D114A-05030A.....	6-24
⇒S/N D114A05030A.....	6-14
HYDRAULIC PUMP ASSEMBLY	
12 CC	
SPLINED SHAFT	
S/N D114A-05031A⇒.....	6-26
HYDRAULIC TANK.....	6-70
I	
INNER MAST	
THREE STAGE FULL FREE-LIFT.....	8-6
TWO STAGE FULL FREE-LIFT.....	9-4
TWO STAGE LIMITED FREE-LIFT.....	7-4
INSTRUMENT CLUSTER	
ECONOMY TRUCK	
⇒S/N D114A-02865W.....	2-22
INTEGRAL SIDE-SHIFT CARRIAGE	
TWO AND THREE STAGE FULL FREE-LIFT.....	10-18
TWO STAGE LIMITED FREE-LIFT.....	10-16
INTEGRAL SIDE-SHIFT CYLINDER.....	10-20
INTEGRAL SIDE-SHIFT HYDRAULIC HOSES	

**TABLE OF CONTENTS (Continued)**

DESCRIPTION	PAGE
I (continued)	
TWO AND THREE STAGE FULL FREE-LIFT .....	10-23
TWO STAGE LIMITED FREE-LIFT .....	10-22
INTERMEDIATE MAST	
THREE STAGE FULL FREE-LIFT .....	8-4
L	
LABELS AND PAINT .....	1-3
LIFT	
TWO STAGE LIMITED FREE-LIFT .....	7-6
LIFT CYLINDER	
LEFT HAND	
TWO STAGE LIMITED FREE-LIFT .....	7-8
RIGHT HAND	
TWO STAGE LIMITED FREE-LIFT .....	7-10
LOAD BACKREST EXTENSION .....	1-32
M	
MAIN CYLINDER	
LEFT HAND	
THREE STAGE FULL FREE-LIFT .....	8-12
TWO STAGE FULL FREE-LIFT	
⇒S/N 559B-01677 .....	9-10
S/N A559B-01678⇒ .....	9-12
RIGHT HAND	
THREE STAGE FULL FREE-LIFT .....	8-14
TWO STAGE FULL FREE-LIFT	
⇒S/N A559B-01677 .....	9-14
S/N A559B-01678⇒ .....	9-16
MAIN LIFT	
THREE STAGE FULL FREE-LIFT .....	8-8
TWO STAGE FULL FREE-LIFT .....	9-6
MAST INSTALLATION .....	6-48
MASTER CYLINDER .....	5-4
O	
OUTER MAST	
THREE STAGE FULL FREE-LIFT .....	8-2
TWO STAGE FULL FREE-LIFT .....	9-2
TWO STAGE LIMITED FREE-LIFT .....	7-2
OVERHEAD GUARD	
D/B 08/1997⇒ .....	1-16
⇒D/B 08/1997 .....	1-14
P	
PARK BRAKE	
ACTUATED LEVER .....	5-10

**TABLE OF CONTENTS (Continued)**

DESCRIPTION	PAGE
<b>S</b>	
SEAT	
FULL SUSPENSION	
SHEET 1 OF 2	
D/B 12/2000⇒ .....	1-28
SHEET 2 OF 2	
D/B 12/2000⇒ .....	1-30
NON-SUSPENSION .....	1-24
SEMI-SUSPENSION .....	1-26
SHIFT LEVER .....	2-24
SIDE-SHIFT CARRIAGE .....	10-12
SIDE-SHIFT CYLINDER .....	10-14
STEERING CONTACTOR	
⇒S/N D114A-02865W .....	2-68
S/N D114A-02866W⇒ .....	2-70
STEERING CONTROL UNIT	
⇒S/N D114V-2817 .....	4-6
S/N D114V-2818⇒ .....	4-8
STEERING CYLINDER	
S/N D114A-2553⇒ .....	4-16
⇒S/N D114V-2552 .....	4-14
STEERING HYDRAULIC .....	4-10
STEERING MOTOR	
⇒S/N D114V-2744 INC. 2751-2754, 2764-2765, 2767 .....	4-24
WITH BWI	
S/N D114A05135A⇒ .....	4-32
S/N D114V02754U⇔S/N D114A05134A .....	4-30
WITHOUT BWI	
S/N D114A05135A⇒ .....	4-28
S/N D114V02745U⇔S/N D114A05134A .....	4-26
STEERING POD .....	4-2
STROBE LIGHT .....	10-34
<b>T</b>	
TILT CYLINDER .....	6-50
TIRE AND WHEEL	
DRIVE WHEEL	
SHEET 1 OF 2 .....	10-4
SHEET 2 OF 2 .....	10-10
SOLID PNEUMATIC .....	10-8
STEER WHEEL .....	10-6 10-2
TRACTION MOTOR	
ECONOMY TRUCK	
⇒S/N D114V-1864 INC. 1951, 1990 .....	3-10
S/N D114V-1864⇔S/N D114A-02865W EXC. 1951, 1990 .....	3-12
ENERGY SAVER TRUCK	
⇒S/N D114V-1864 INC. 1951, 1990 .....	3-14
S/N D114V-1864⇔S/N D114A-02865W EXC. 1951, 1990 .....	3-16
HIGH SPEED WITH BRUSH WEAR INDICATORS	
S/N D114A-02866W⇒ .....	3-20
HIGH SPEED WITHOUT BRUSH WEAR INDICATORS	
S/N D114A-02866W⇒ .....	3-22

## TABLE OF CONTENTS (Continued)

DESCRIPTION	PAGE
<b>T (continued)</b>	
LOW SPEED WITH BRUSH WEAR INDICATORS	
S/N D114A-02866W⇒ .....	3-24
PERFORMANCE TRUCK	
⇒S/N D114A-02865W .....	3-18
TRAIL AXLE .....	4-34
TRANSISTOR ASSEMBLY	
⇒S/N D114A-02865W .....	2-60
TRANSISTOR CONTROL PANEL	
CONTACTOR HYDRAULIC	
⇒S/N D114A-02865W .....	2-46
S/N D114A-02866W⇒ .....	2-48
TRANSISTOR HYDRAULIC	
S/N D114A-02865W⇒ .....	2-52
⇒S/N D114A-02865W .....	2-50
<b>W</b>	
WIRE HARNESS	
CHASSIS	
⇒S/N D114A-02090V .....	2-32
S/N D114A-02091V⇔S/N D114A-02865W .....	2-34
CONTROL VALVE SWITCH	
S/N D114A-02866W⇒ .....	2-44
HAND LEVER	
CONTACTOR HYDRAULIC	
⇒S/N D114A-02865W.....	2-37
TRANSISTOR HYDRAULIC	
⇒S/N D114A-02865W.....	2-38
IGNITION SWITCH.....	2-31
INSTRUMENT CLUSTER	
CONTACTOR HYDRAULIC ENERGY SAVER AND PERFORMANCE TRUCK	
⇒S/N D114A-02865W.....	2-30
ECONOMY TRUCK	
⇒S/N D114A-02865W.....	2-29
TRANSISTOR HYDRAULIC ENERGY SAVER AND PERFORMANCE TRUCK	
⇒S/N D114A-02865W.....	2-27
LIGHTS	
S/N D114A-02866W⇒ .....	2-35
⇒S/N D114A-2865.....	10-37
S/N D114A-2866⇒.....	10-38
MAIN	
S/N D114A-02866W⇒ .....	2-42
MAIN SCR CONTROL	
⇒S/N D114A-02865W .....	2-40
MAIN TRANSISTOR CONTROLLER	
S/N D114V-02679⇔S/N D114A-02865W .....	2-41
ON-DEMAND STEERING	
⇒S/N D114A-02865W .....	2-26
STEERING MOTOR	
TRANSISTOR HYDRAULIC	



**TABLE OF CONTENTS (Continued)**

DESCRIPTION	PAGE
<b>W</b> (continued)	
⇒S/N D114A-02865W.....	2-36
TRANSISTOR CONTROLLER WITH BDI	
⇒S/N D114A-02865W .....	2-28
WORK AND REAR DRIVE LIGHTS.....	10-32

**SECTION 1**  
**FRAME**

DESCRIPTION	PAGE
COUNTERWEIGHT .....	1-18
COVERS .....	1-10
FORKS .....	1-34
FRAME .....	1-6
HOOD .....	1-20
LABELS AND PAINT .....	1-3
LOAD BACKREST EXTENSION .....	1-32
OVERHEAD GUARD	
D/B 08/1997⇒ .....	1-16
⇒D/B 08/1997 .....	1-14
SEAT	
FULL SUSPENSION	
SHEET 1 OF 2	
D/B 12/2000⇒ .....	1-28
SHEET 2 OF 2	
D/B 12/2000⇒ .....	1-30
NON-SUSPENSION .....	1-24
SEMI-SUSPENSION .....	1-26

## LABELS AND PAINT (Figure 1-1)

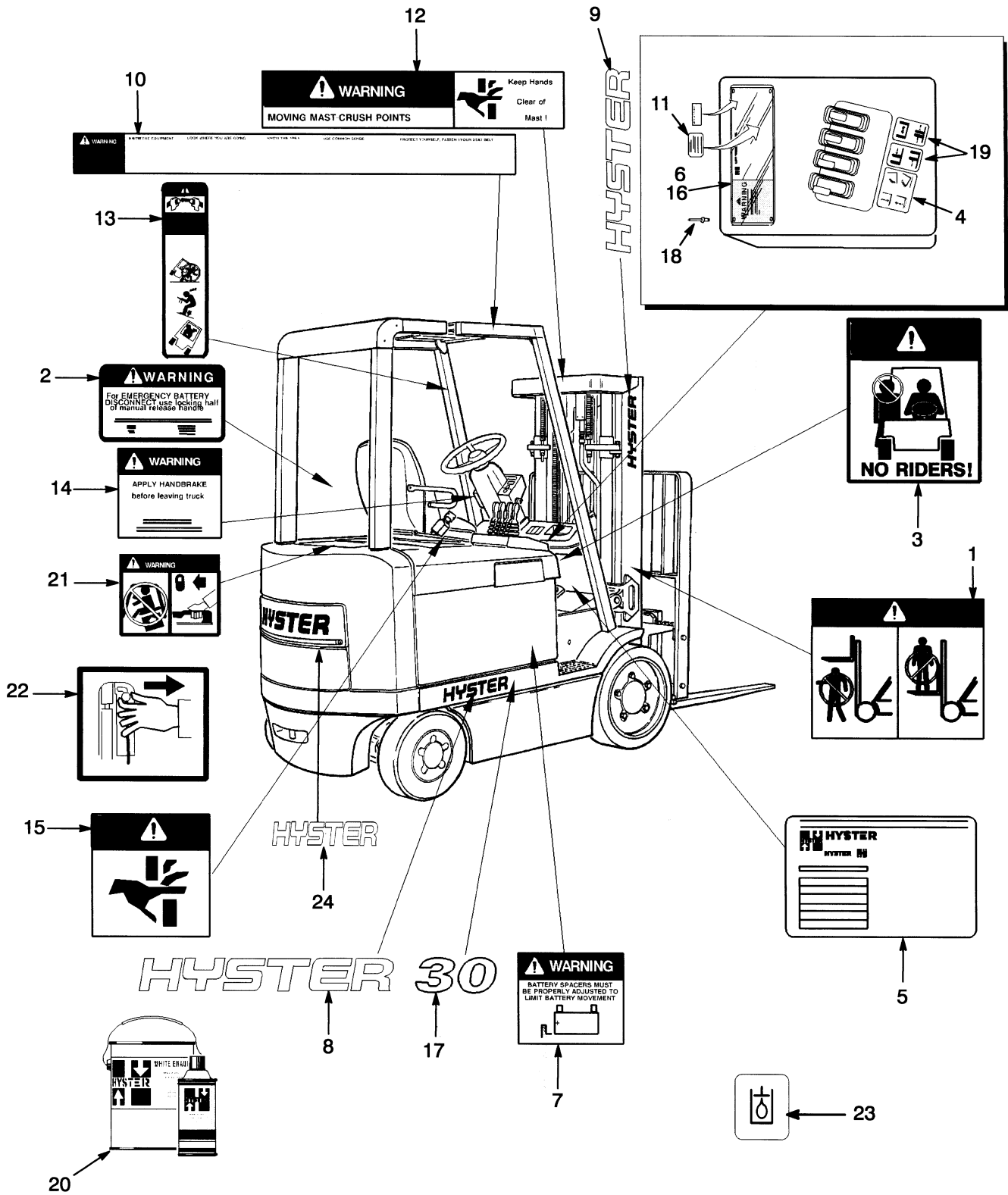

HP120202

**LABELS AND PAINT**

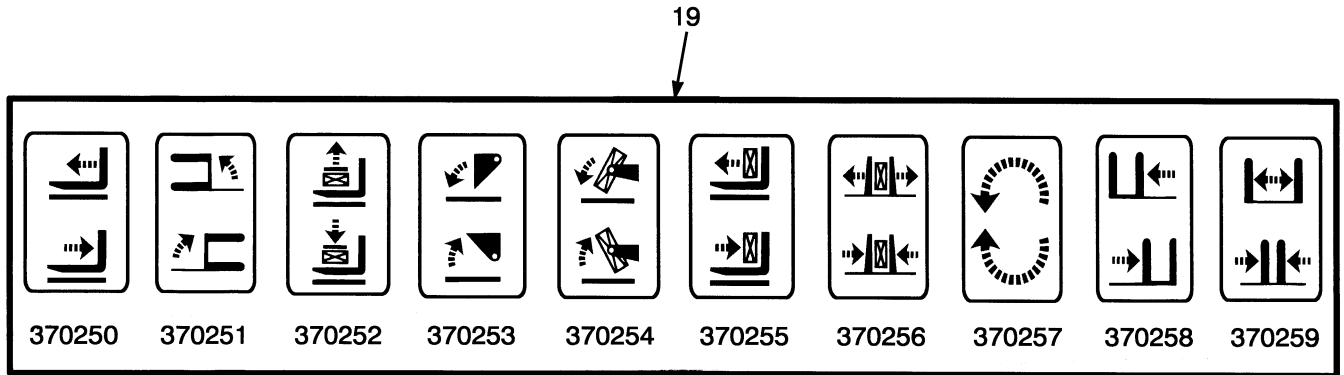

HP120066

ITEM	PART NO.	DESCRIPTION	QTY
1	1339830	Label (Mast Warning) .....	2
2	1335164	Label (Battery Disconnect) .....	1
3	1339828	Label (No Riders) .....	2
4	369573	Label (Lift/Tilt).....	1
5	320037	Label (Patent Plate) .....	2
6	a . . . . .	Nameplate .....	1
7	1342699	Label (Battery Spacer).....	1
8	1339674	Label (Hyster) .....	2
9	1339672	Label (Hyster) .....	2
10	1335140	Label (Operator Warning).....	1
11	1335138	Nameplate Tag .....	1
12	1343276	Label (Mast Warning) .....	1
13	1335143	Label (Tip Over Warning) .....	2
14	1357001	Label (Park Brake Warning).....	2
15	1339832	Label (Pinch Point) .....	1
16	389687	Nameplate Cover .....	1
17	1339667	Label (Model 2.00).....	2
17	2026000	Label (Model 1.50).....	2
17	2026001	Label (Model 1.75).....	2
18	1377476	Rivet.....	4
19	370250	Label (Auxiliary Function - Reach) .....	1
19	370251	Label (Auxiliary Function - Swing) .....	1
19	370252	Label (Auxiliary Function - Stabilizer) .....	1
19	370253	Label (Auxiliary Function - Dump/Scoop) .....	1
19	370254	Label (Auxiliary Function - Upender) .....	1
19	370255	Label (Auxiliary Function - Push/Pull).....	1
19	370256	Label (Auxiliary Function - Clamp) .....	1
19	370257	Label (Auxiliary Function - Rotate) .....	1
19	370258	Label (Auxiliary Function - Side-Shift) .....	1
19	370259	Label (Auxiliary Function - Fork Spreader) .....	1
20	1344901	Paint (Low Gloss Black) (Spray) .....	AR
20	1344902	Paint (Low Gloss Black) (One Gallon) (3,8L).....	AR
20	1345808	Paint (Yellow) (One Gallon) (3,8L) .....	AR
20	1345809	Paint (Yellow) (Spray).....	AR
20	316844	Paint (Red) (Spray) .....	AR
21	1379808	Label (Hood Latch) .....	1
22	1379443	Label (Prop Rod) .....	1
23	1385099	Label (Hydraulic Oil Fill).....	1

## LABELS AND PAINT

ITEM	PART NO.	DESCRIPTION	QTY
24	<b>b</b> 893523	Label (Hyster) (Counterweight).....	1
24	<b>b</b> 1526709	Label (Hyster) (Counterweight).....	1

**FOOTNOTES:**

- a** Contact Your Local Hyster Dealer
- b** Optional



## FRAME (Figure 1-2)

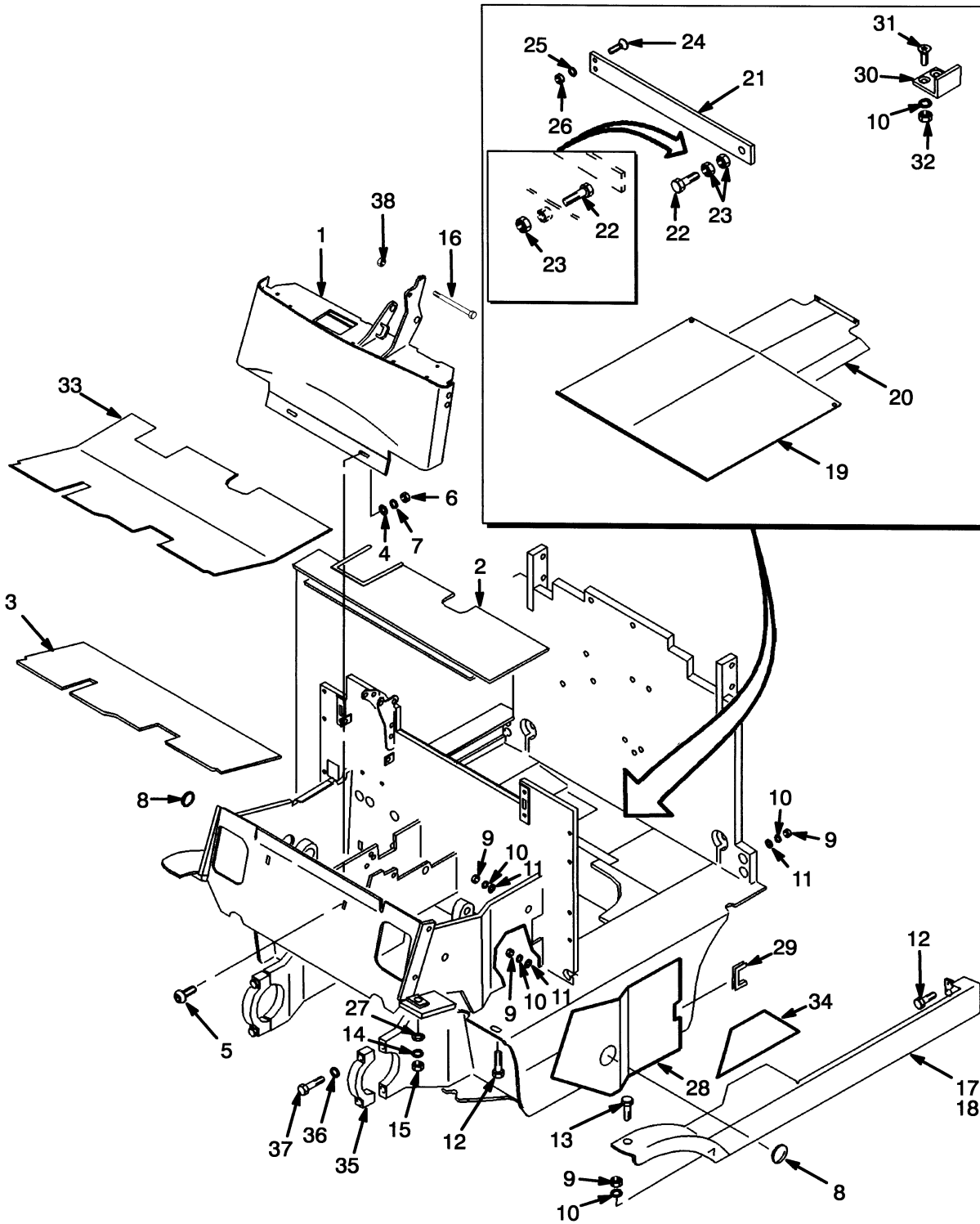

HP120204

**FRAME****KEY:****A: 878 mm Battery Compartment****B: 909 mm Battery Compartment**

ITEM	PART NO.	DESCRIPTION	QTY	
			A	B
1	<b>h</b> 1340178	Cowl.....	1	1
1	<b>i</b> 1452068	Cowl.....	1	1
1	<b>d</b> 1460339	Cowl.....	1	1
1	<b>e</b> 1465530	Cowl.....	1	1
2	<b>f</b> 1389585	Floorplate.....	1	1
2	<b>g</b> 2026813	Floorplate.....	1	1
3	1389584	Floorplate.....	1	1
4	15176	Washer .....	8	8
5	17105	Bolt .....	2	2
6	15056	Nut .....	2	2
7	15156	Lockwasher.....	2	2
8	<b>j</b> 1350231	Plug .....	2	2
9	<b>j</b> 136692	Nut .....	11	11
9	<b>k</b> 136692	Nut .....	8	8
10	<b>j</b> 292682	Lockwasher.....	15	15
10	<b>k</b> 292682	Lockwasher.....	8	8
11	<b>j</b> 1356113	Washer .....	11	11
11	<b>k</b> 1356113	Washer .....	8	8
12	136985	Capscrew.....	4	4
13	292529	Capscrew.....	2	2
14	292683	Lockwasher.....	2	2
15	216877	Nut .....	2	2
16	18494	Capscrew.....	1	1
17	2026805	Fender (LH) .....	1	..
17	2026807	Fender (LH) .....	..	1
17	<b>b</b> 2026806	Fender (LH) .....	1	..
17	<b>b</b> 2026808	Fender (LH) .....	..	1
17	<b>ac</b> 1461663	Fender (LH) .....	1	..
17	<b>ac</b> 1461664	Fender (LH) .....	..	1
18	2026809	Fender (RH) .....	1	..
18	2026811	Fender (RH).....	..	1
18	<b>b</b> 2026810	Fender (RH).....	1	..
18	<b>b</b> 2026812	Fender (RH).....	..	1
18	<b>ac</b> 1461666	Fender (RH).....	1	..
18	<b>ac</b> 1461667	Fender (RH).....	..	1
18	<b>k</b> 287860	Capscrew.....	2	2
18	<b>k</b> 1356113	Washer .....	2	2
19	2023868	Cover .....	1	1
20	2023947	Cover .....	1	1
21	<b>f</b> 2023978	Plate .....	1	1
22	<b>f</b> 292584	Capscrew.....	1	1
23	<b>f</b> 296136	Nut .....	2	2
24	<b>f</b> 296227	Capscrew.....	2	2
25	<b>f</b> 292681	Lockwasher.....	2	2
26	<b>f</b> 239503	Nut .....	2	2
27	320162	Washer .....	2	2



## FRAME

ITEM	PART NO.	DESCRIPTION	QTY	
			A	B
28	j 1389586	Cover (LH) .....	1	1
29	j 1345675	Trim .....	1	1
30	2023979	Spacer .....	2	2
31	296239	Capscrew .....	4	4
32	292655	Nut .....	4	4
33	g 2026804	Floor Mat .....	1	1
34	g 2026817	Pad .....	1	1
35	1370722	Cap .....	2	2
36	292683	Lockwasher .....	4	4
37	293651	Capscrew .....	4	4
38	169874	Nut .....	1	1

**FOOTNOTES:**

- a Extra Wide
- b Wide Track
- c S/N D114A-02853W ⇒
- d S/N D114A-02866W ⇒
- e S/N D114A-03383X ⇒
- f ⇒ S/N D114A-1585
- g S/N D114A-1586 ⇒
- h ⇒ S/N D114V-2678
- i S/N D114V-2679⇔S/N PENDING PER ECN 72804
- j ⇒ S/N D114V-3560
- k S/N D114V-3561 ⇒



## COVERS (Figure 1-3)

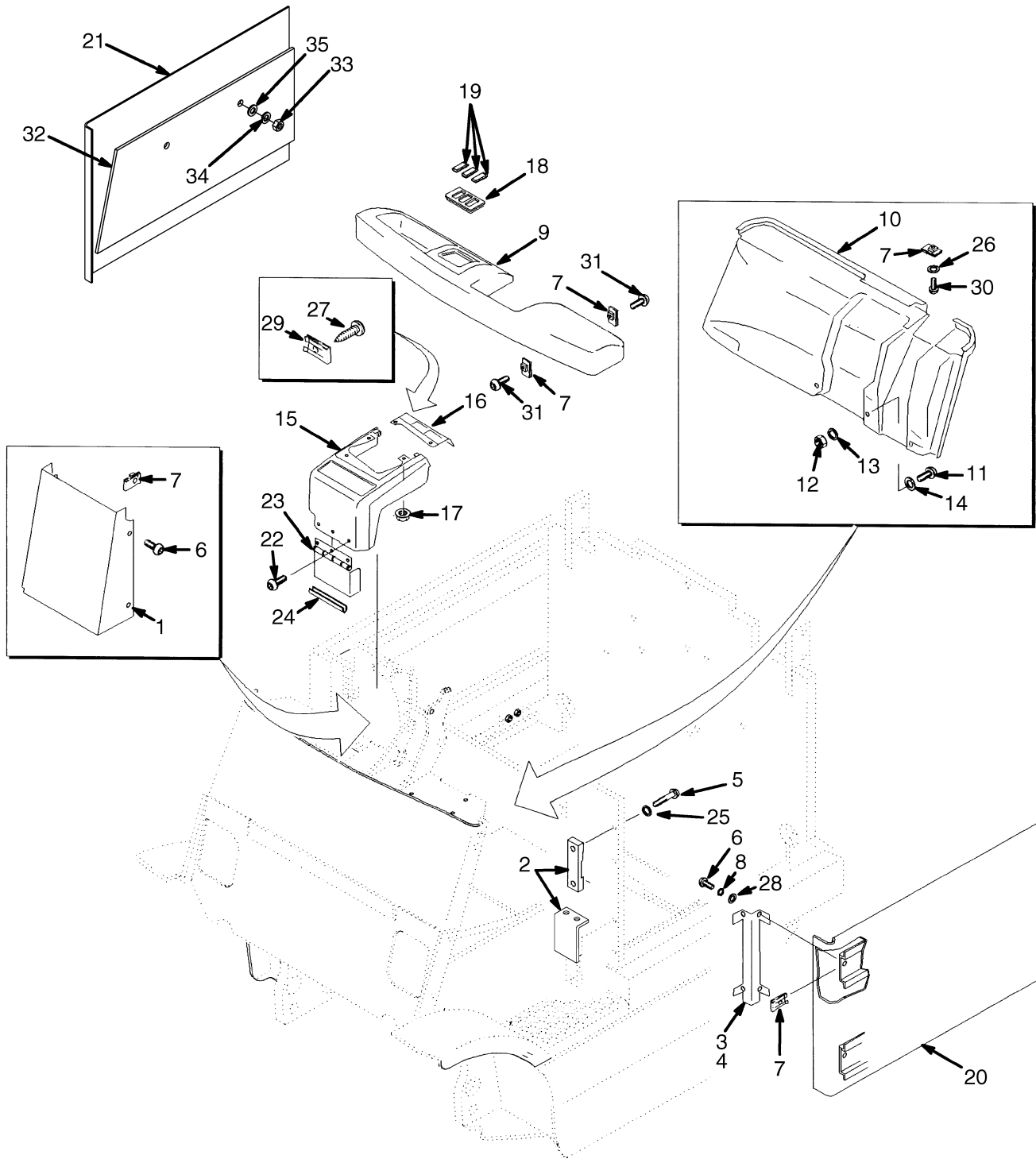

HP120205

**COVERS****KEY:****A: 878 mm Battery Compartment****B: 909 mm Battery Compartment**

ITEM	PART NO.	DESCRIPTION	QTY	
			A	B
1	1388314	Cover (Without Raised Battery) .....	1	1
1	1388315	Cover (With Raised Battery) .....	1	1
2	<b>h</b> 2023901	Catch .....	2	2
2	<b>i</b> 2049954	Plate .....	1	..
3	<b>h</b> 2023902	Plate .....	1	1
4	2023903	Plate .....	3	3
5	<b>h</b> 296166	Capscrew .....	4	4
5	<b>i</b> 296166	Capscrew .....	2	..
6	<b>h</b> 296159	Capscrew .....	11	11
6	<b>i</b> 296159	Capscrew .....	7	7
7	<b>h</b> 1354323	Nut (Foldover) .....	21	21
7	<b>i</b> 1354323	Nut (Foldover) .....	17	17
8	<b>h</b> 292680	Lockwasher .....	8	8
8	<b>i</b> 292680	Lockwasher .....	4	4
9	<b>e</b> 1339086	Dash .....	1	1
9	<b>f</b> 1460633	Dash .....	1	1
9	<b>a</b> 1465533	Dash .....	1	1
10	<b>b</b> 1339088	Liner .....	1	1
10	<b>d</b> 1390322	Liner .....	1	1
10	<b>g</b> 1460397	Liner .....	1	1
11	296167	Capscrew .....	2	2
12	239503	Nut .....	2	2
13	292681	Lockwasher .....	2	2
14	<b>b</b> 1300117	Washer .....	2	2
14	<b>c</b> 320158	Washer .....	2	2
15	1381909	Cover .....	1	1
16	1381910	Cover .....	1	1
17	169874	Nut .....	3	3
18	1382311	Mounting Panel (End) .....	2	2
18	1382312	Mounting Panel (Center) .....	1	1
19	1382313	Mounting Panel (With Lights) .....	2	2
19	1382313	Mounting Panel (Without Lights) .....	3	3
20	<b>h</b> 2023904	Cover (LH) .....	1	1
20	<b>i</b> 1491723	Cover (LH) .....	1	1
21	<b>h</b> 2023905	Cover (RH) .....	1	1
21	<b>i</b> 1491721	Cover (RH) .....	1	1
22	1364399	Screw .....	3	3
23	1364395	Cover .....	1	1
24	1376812	Trim .....	1	1
25	<b>h</b> 296360	Washer .....	4	4
25	<b>i</b> 296360	Washer .....	2	..
26	<b>h</b> 15127	Washer .....	3	3
26	<b>i</b> 15127	Washer .....	8	8
27	296159	Capscrew .....	3	3
28	197068	Washer .....	8	8
29	1381918	Nut (Foldover) .....	2	2

## COVERS

ITEM	PART NO.	DESCRIPTION	QTY	
			A	B
30	296161	Capscrew .....	3	3
31	353144	Capscrew .....	7	7
32	2026818	Plate .....	1	1
33	136692	Nut .....	2	2
34	292682	Lockwasher.....	2	2
35	1356113	Washer .....	2	2

### FOOTNOTES:

- a** S/N D114A03383X ⇒
- b** ⇒ S/N D114A-1815 EXC. 2828
- c** S/N D114A-1816 ⇒ EXC. 2828
- d** S/N D114A-1816⇔S/N D114V-3841 EXC. 2828
- e** ⇒ S/N D114V-2678 EXC. 2828
- f** S/N D114V2679⇔S/N D114A03382X EXC. 2828
- g** S/N D114V-3842 ⇒ EXC. 2828
- h** ⇒ D/B 10/2000
- i** D/B 10/2000 ⇒



## OVERHEAD GUARD (Figure 1-4) (⇒D/B 08/1997)

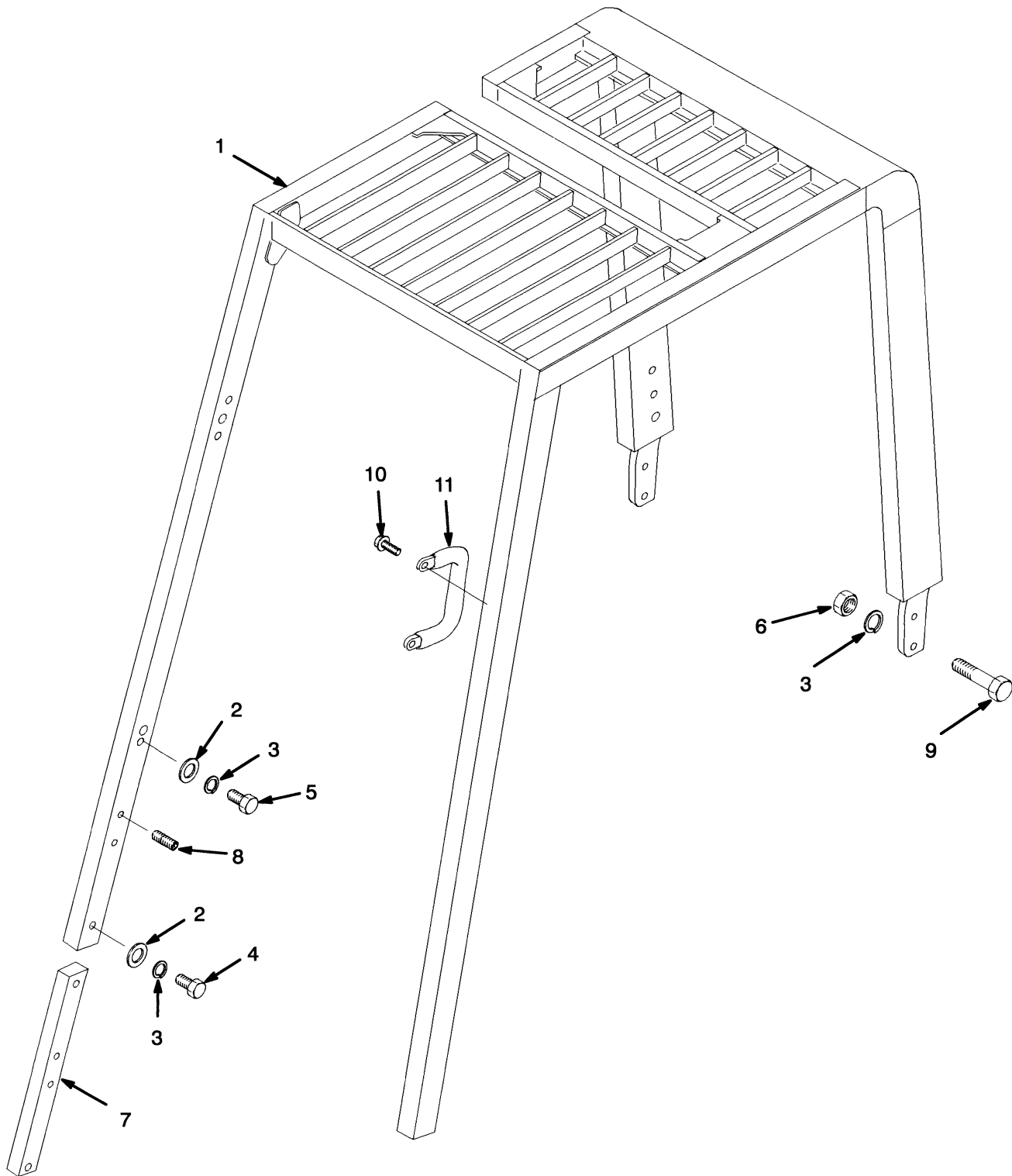

HP120206

**OVERHEAD GUARD**  
(⇒D/B 08/1997)

ITEM	PART NO.	DESCRIPTION	QTY
1	2023610	Overhead Guard (Raised Height) .....	1
1	2023611	Overhead Guard (Standard Height).....	1
2	320161	Washer .....	10
3	292683	Lockwasher.....	10
4	293649	Capscrew.....	8
5	293647	Capscrew.....	2
6	216877	Nut .....	4
7	2023866	Bar .....	2
8	302220	Screw.....	2
9	293651	Capscrew.....	4
10	329067	Screw.....	2
11	1343647	Handle .....	1



## OVERHEAD GUARD (Figure 1-5) (D/B 08/1997⇒)

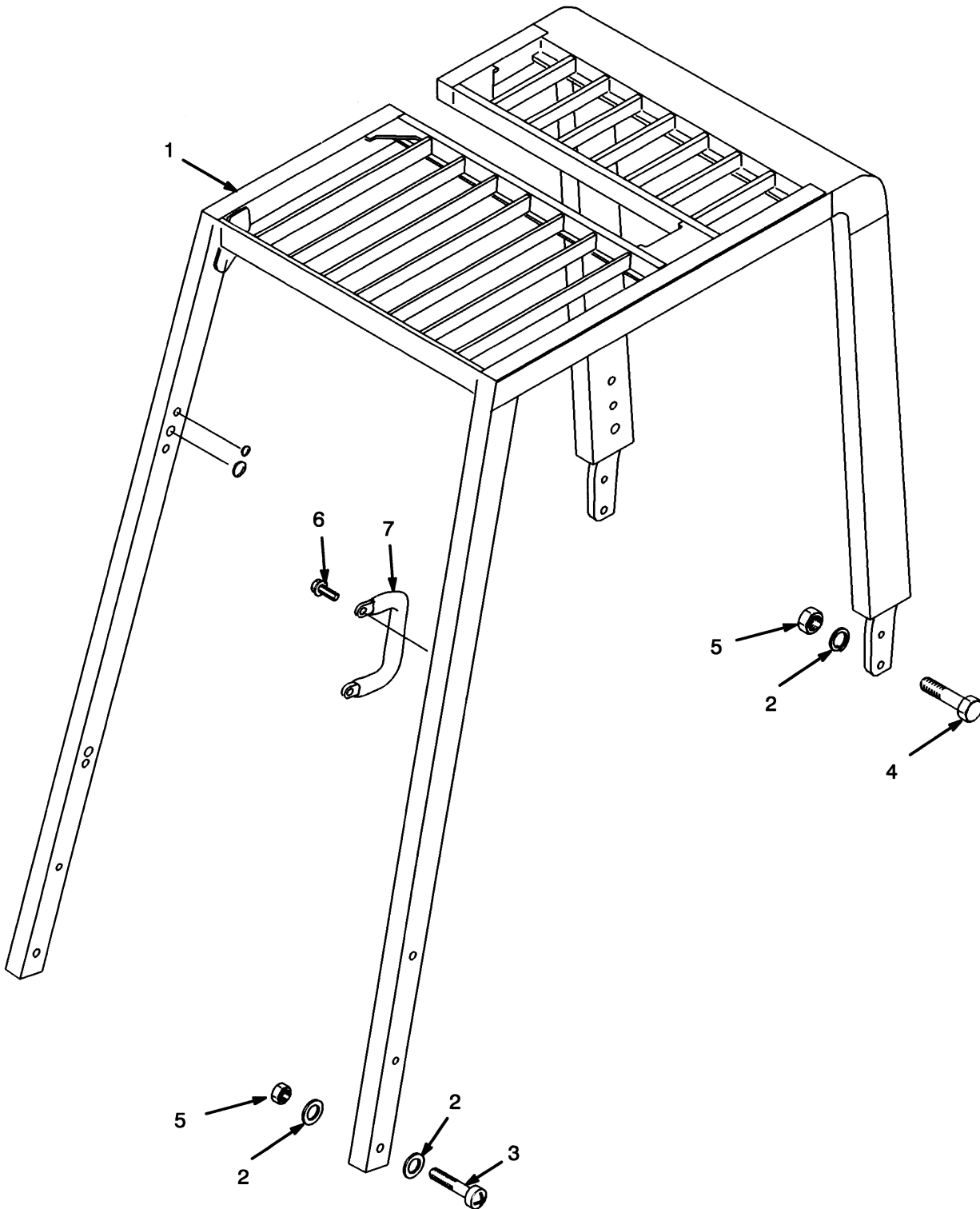

HP120207

**OVERHEAD GUARD**  
**(D/B 08/1997⇒)**

ITEM	PART NO.	DESCRIPTION	QTY
1	<b>a</b> 2026636	Overhead Guard (Standard Height).....	1
1	<b>b</b> 2026825	Overhead Guard (Standard Height).....	1
1	<b>a</b> 2026635	Overhead Guard (Raised Height).....	1
1	<b>b</b> 2026826	Overhead Guard (Raised Height).....	1
2	320161	Washer .....	16
3	1343990	Capscrew.....	6
4	293561	Capscrew.....	4
5	1390182	Nut .....	10
6	329067	Screw.....	2
7	1343647	Handle .....	1

**FOOTNOTES:**

- a** ⇒ S/N D114V-2232 EXC. 2828  
**b** S/N D114V-2233 ⇒ EXC. 2828

## COUNTERWEIGHT (Figure 1-6)

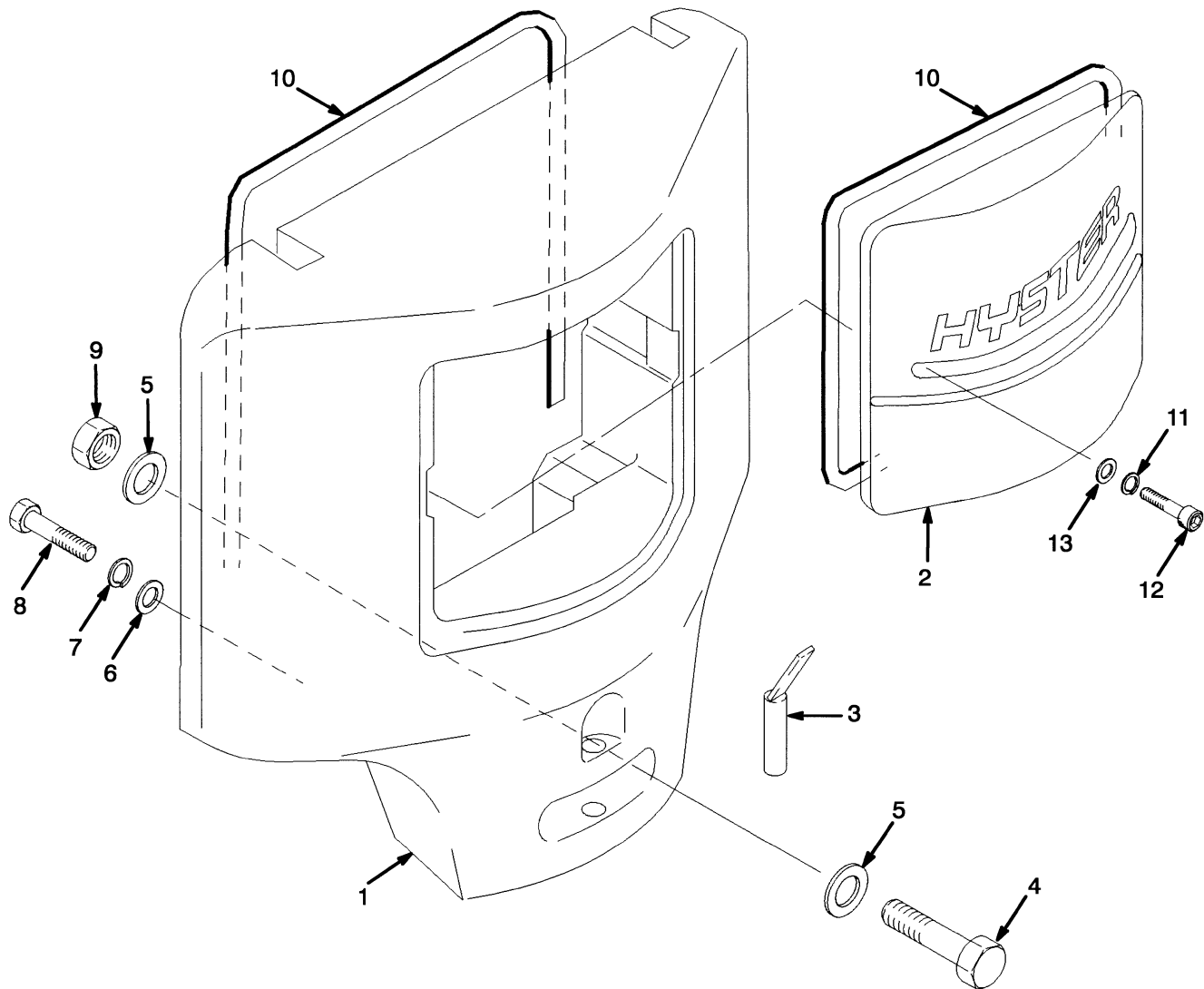

HP120208

**COUNTERWEIGHT**

ITEM	PART NO.	DESCRIPTION	QTY
1	2023884	Counterweight (E1.50XM) .....	1
1	2023885	Counterweight (E1.75XM) .....	1
1	2023886	Counterweight (E2.00XMS) .....	1
2	1340460	Cover .....	1
3	326347	Tow Pin .....	1
4	292537	Capscrew .....	2
5	296423	Washer .....	4
6	221777	Washer .....	2
7	15162	Lockwasher .....	2
8	168054	Capscrew .....	2
9	300937	Locknut .....	2
10	326003	Tape .....	AR
11	15134	Washer .....	2
12	46698	Capscrew .....	2
13	15156	Lockwasher .....	2
	239536	Compound .....	AR

## HOOD (Figure 1-7)

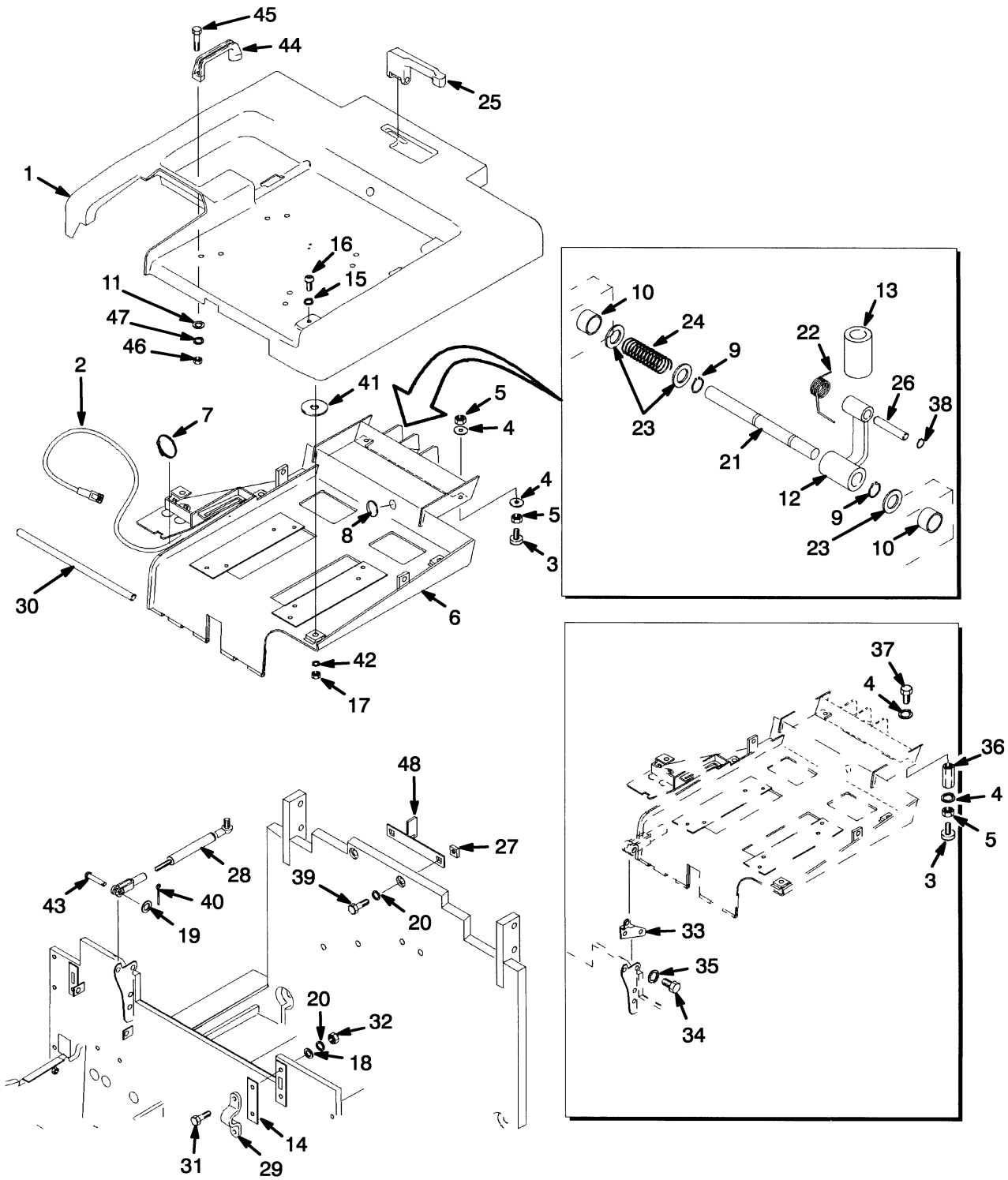

HP120209

**HOOD****KEY:****A: 878 mm Battery Compartment****B: 909 mm Battery Compartment**

ITEM	PART NO.	DESCRIPTION	QTY	
			A	B
1	2023702	Hood .....	1	..
1	2023844	Hood .....	..	1
2	1340531	Wire Harness .....	1	1
3	<b>a</b> 1347088	Stop Screw .....	2	2
3	<b>b</b> 367251	Stop Screw .....	2	2
4	15155	Lockwasher .....	4	4
5	<b>a</b> 15055	Nut .....	2	2
5	<b>b</b> 15055	Nut .....	4	4
6	<b>c</b> 2023843	Frame .....	1	1
6	<b>d</b> 2026605	Frame .....	1	1
7	114312	Strap Clamp .....	5	5
8	1359587	Grommet .....	1	1
9	353569	Retaining Ring .....	2	2
10	368618	Bushing .....	2	2
11	15127	Washer .....	2	2
12	1378900	Link .....	1	1
13	1378902	Collar .....	1	1
14	325616	Spacer .....	AR	AR
15	320160	Washer .....	5	5
16	296173	Capscrew .....	5	5
17	316826	Nut .....	5	5
18	320159	Washer .....	2	2
19	18515	Washer .....	1	1
20	292682	Lockwasher .....	4	4
21	1377674	Shaft .....	1	1
22	1377670	Spring .....	1	1
23	15125	Washer .....	1	1
24	1364538	Spring .....	1	1
25	1378976	Handle .....	1	1
26	1378975	Pin .....	1	1
27	1364537	Plate .....	2	2
28	1385758	Gas Spring .....	1	1
29	355374	Clamp .....	1	1
30	<b>e</b> 1340095	Bar .....	1	1
30	<b>f</b> 1468405	Bar .....	1	1
31	136985	Capscrew .....	2	2
32	136692	Nut .....	2	2
33	<b>a</b> 1377378	Bracket .....	1	1
34	<b>ae</b> 293612	Capscrew .....	2	2
34	<b>af</b> 293613	Capscrew .....	2	2
35	<b>a</b> 292681	Lockwasher .....	2	2
36	<b>a</b> 1364729	Spacer .....	2	2
37	<b>a</b> 16394	Capscrew .....	2	2
38	12892	Snap Ring .....	2	2
39	292515	Capscrew .....	2	2
40	15212	Cotter Pin .....	1	1

## HOOD

ITEM	PART NO.	DESCRIPTION	QTY	
			A	B
41	1383680	Spacer .....	5	5
42	15157	Lockwasher.....	5	5
43	139	Rod End Pin .....	1	1
44	362030	Handle .....	1	1
45	287816	Capscrew.....	2	2
46	136687	Nut .....	2	2
47	292680	Lockwasher.....	2	2
48	<b>b</b> 1364597	Latch.....	1	1
48	<b>a</b> 1364747	Latch.....	1	1

### FOOTNOTES:

- a** With Raised Battery
- b** Without Raised Battery
- c** ⇒ S/N D114A-1585
- d** S/N D114A-1586 ⇒
- e** ⇒ S/N D114V-4754 EXC. 4735-4736, 4751
- f** S/N D114V-4755 ⇒ INC. 4735-4736, 4751

Thank you so much for reading.  
Please click the “Buy Now!”  
button below to download the  
complete manual.



After you pay.

You can download the most  
perfect and complete manual in  
the world immediately.

Our support email:

[ebooklibonline@outlook.com](mailto:ebooklibonline@outlook.com)