

PARTS MANUAL

CHALLENGER

H13.00-16.00XM-6

H10.00-12.00XM-12EC

(E019)

CUSTOMER EDITION

HYSTER

SECTIONS

1	FRAME
2	ENGINES
3	FUEL SYSTEM
4	ELECTRICAL SYSTEM
5	TRANSMISSION
6	DRIVE AXLE
7	STEERING SYSTEM
8	BRAKE SYSTEM
9	HYDRAULIC SYSTEM
10	MAST-TWO STAGE LIMITED FREE-LIFT
11	OPTIONS
12	NUMERICAL INDEX

TABLE OF CONTENTS

DESCRIPTION	PAGE
A	
ACCUMULATOR	8-12
PISTON TYPE	9-8
AIR COMPRESSOR	
SHEET 1 OF 2	2-52
SHEET 2 OF 2	2-54
AIR COMPRESSOR AND ATTACHING PARTS	2-50
AIR CONDITIONER	
PERKINS	1-42
AIR DRYER AND ATTACHING PARTS	2-20
AIR DRYER ASSEMBLY	2-22
AIR DUCT	
CAB	1-72
TIER I ENGINE	2-46
AIR FILTER SYSTEM	
WITHOUT ASPIRATED PRE-CLEANER	
TIER I ENGINE	3-28
TIER II ENGINE	3-30
ALARM	11-48
ALTERNATOR	4-18
ALTERNATOR AND PULLEY	
PERKINS	
TIER II ENGINE	4-22
ALTERNATOR BRACKET AND ATTACHING PARTS	
PERKINS	
TIER II ENGINE	4-20
ARMREST	
PIVOT-UP	1-82
AUXILIARY DRIVE GEAR	
TIER I ENGINE	2-32
TIER II ENGINE	2-84
AXLE HOUSING AND ATTACHING PARTS	6-18
B	
BLANKING PLATE AND PLUGS	
TIER II ENGINE	2-88
BLANKING PLUG, OIL FEED AND HOSES	
TIER II ENGINE	2-86
BRAKE ASSEMBLY	
DRY BRAKE	8-16
WET BRAKE	8-14
BRAKE CHAMBER	8-18
BRAKE SYSTEM	
DRY	8-6
WET	8-2
BRAKE VALVE	
DRY BRAKE	8-22
WET BRAKE	8-20

TABLE OF CONTENTS (Continued)

DESCRIPTION	PAGE
C	
CAB AND ATTACHING PARTS	1-14
CAB AND TILT CYLINDER MOUNTING.....	1-30
CAB HARDWARE AND CONTROL COVER.....	1-66
CAB MOUNTED DRIVE LIGHTS.....	11-44
CAMSHAFT AND ROCKER ASSEMBLY	
TIER II ENGINE.....	2-66
CARRIAGE	
FOUR, FIVE, AND SIX FUNCTION	
S/N E019E-01951A⇒	10-18
SIMULTANEOUS FORK POSITIONER	10-26
CARRIAGE ASSEMBLY	
FOUR AND FIVE FUNCTION	
⇒S/N E019E-01950A	10-16
INDIVIDUAL FORK POSITIONER	
FOUR FUNCTION	
S/N E019E-01951A⇒.....	10-22
⇒S/N E019E-01950A	10-20
THREE FUNCTION	10-14
CHARGE PUMP.....	5-24
CLUTCH	
FORWARD AND LOW.....	5-14
REVERSE AND SECOND.....	5-16
THIRD.....	5-18
CONDENSER.....	1-52
CONTROL LEVER	
ELECTRONIC	
S/N E019E-01915A⇒	9-34
HYDRAULIC	
⇒S/N E019E-01914A	9-32
CONTROL PANEL	
AIR CONDITIONER.....	4-12
HEATER.....	4-10
CONTROL VALVE	
⇒S/N E019E-01696Z (FLT), ⇒S/N E019E-01699Z (ECH).....	9-20
S/N E019E-01697Z⇒ (FLT), S/N E019E-01700Z⇒ (ECH).....	9-22
TRANSMISSION.....	5-28
COOLING	
TIER I ENGINE.....	2-10
TIER II ENGINE.....	2-12
COUNTERWEIGHT	1-8
CRANKSHAFT AND MAIN BEARINGS	
TIER II ENGINE.....	2-62
CRANKSHAFT AND PISTON	
TIER I ENGINE.....	2-26
CYLINDER BLOCK	
TIER I ENGINE.....	2-24
TIER II ENGINE.....	2-56
CYLINDER HEAD	
TIER I ENGINE.....	2-28
TIER II ENGINE.....	2-58
CYLINDER HEAD COVER	

TABLE OF CONTENTS (Continued)

DESCRIPTION	PAGE
C (continued)	
TIER II ENGINE	2-60
D	
DASH DISPLAY	
CAB.....	1-74
DC-DC CONVERTER AND ATTACHING PARTS.....	4-14
DIFFERENTIAL AND CARRIER	
DRY BRAKE	
⇒S/N E019E-02009A	6-10
S/N E019E-02010A⇒	6-14
WET BRAKE	
⇒S/N E019E-02009E	6-2
S/N E019E-02010A⇒	6-6
DIRECTIONAL CONTROL VALVE	
S/N E019E-01951A⇒.....	11-32
DOOR	
GLASS	1-18
STEEL	
⇒S/N E019E02149B.....	1-22
E	
ELECTRIC PUMP	1-38
ELECTRICAL SYSTEM	
CONTAINER HANDLING ATTACHMENT (553)	
⇒S/N E019E-01809Z.....	11-108
CONTAINER HANDLING ATTACHMENT (555)	
⇒S/N E019E-01809Z.....	11-112
CONTAINER HANDLING ATTACHMENT (558)	
⇒S/N E019E-01809Z.....	11-116
SERIES 553	
250 MM (10 IN.) SIDE-SHIFT	
S/N E019E-01810Z⇒	11-110
SERIES 555	
S/N E019E-01810Z⇒.....	11-114
SERIES 558	
250 MM (10 IN.) SIDE-SHIFT	
S/N E019E-01810Z⇒	11-118
TIER I ENGINE.....	4-2
TIER II ENGINE.....	4-6
ELECTRONIC CONTROL MODULE AND MOUNTING	
TIER II ENGINE.....	2-106
END BEAM ASSEMBLY	
CONTAINER HANDLING ATTACHMENT (555).....	11-74
CONTAINER HANDLING ATTACHMENT (558)	
250 MM (10 IN.) SIDE-SHIFT	11-76
EMPTY CONTAINER HANDLER (553)	
⇒S/N E019E-01809Z.....	11-70
SERIES 553	
250 MM (10 IN.) SIDE-SHIFT	

TABLE OF CONTENTS (Continued)

DESCRIPTION	PAGE
E (continued)	
S/N E019E-01810Z⇒	11-72
ENGINE ASSEMBLY	2-4
ENGINE BLOCK HEATER	2-18
ENGINE LIFTING EYES	
TIER II ENGINE	2-104
ENGINE MOUNT	
PERKINS	2-15
EXHAUST	
TIER I ENGINE	2-6
TIER II ENGINE	2-8
EXTENSION CYLINDER	
SERIES 553, 558	
250 MM (10 IN.) SIDE-SHIFT	11-80
EXTENSION CYLINDER AND ATTACHING PARTS	
SERIES 555	11-84
F	
FAN DRIVE AND PULLEY	
TIER II ENGINE	2-82
FLOOR PLATES AND COVERS	
⇒S/N E019E01957A	1-10
S/N E019E01958A⇒	1-12
FLYWHEEL	
PERKINS	2-16
FORK.....	10-30
FORK POSITIONER CYLINDER	11-34
FRONT DRIVE PULLEY	
TIER II ENGINE	2-80
FRONT, BRAKE AND BACK-UP LIGHTS	11-40
FUEL FILTER	
TIER I ENGINE	3-12
FUEL FILTER ASSEMBLY	
TIER II ENGINE	3-24
FUEL INJECTION	
TIER I ENGINE	3-6
FUEL INJECTION PUMP AND GEAR	
TIER II ENGINE	3-14
FUEL INJECTION SUPPLY AND RETURN LINES	
TIER II ENGINE	3-18
FUEL SYSTEM	
PERKINS	
TIER I ENGINE	3-2
TIER II ENGINE	3-4
G	
GENERAL TRUCK	1-2

TABLE OF CONTENTS (Continued)

DESCRIPTION	PAGE
H	
HAND PUMP	
CAB TILT.....	1-36
HEADER HOSE	
EMPTY CONATAINER HANDLER	
S/N E019E-01951A⇒	11-58
EMPTY CONTAINER HANDLER	
⇒S/N E019E-01950A	11-54
TWO STAGE LIMITED FREE-LIFT	
⇒S/N E019E-01950A	10-32
S/N E019E-01951A⇒	10-36
HEATER AND AIR CONDITIONER.....	1-44
HEATER AND AIR CONDITIONER ASSEMBLY.....	1-50
HEATER AND AIR CONDITIONER ATTACHMENT	1-46
HEATER ARRANGEMENT	
PERKINS	1-40
HEATER ASSEMBLY	1-48
HIGH PRESSURE FUEL PIPES	
TIER II ENGINE.....	3-16
HOOD.....	1-4
HUB AND SHAFT ASSEMBLY	
DRY BRAKE	
⇒S/N E019E-02009A	6-24
S/N E019E-02010A⇒	6-26
WET BRAKE	
⇒S/N E019E-02009A	6-20
S/N E019E-02010A⇒	6-22
HYDRAULIC CONTROL AND TWISTLOCK	
EMPTY CONATAINER HANDLER.....	1-78
HYDRAULIC PUMP.....	9-14
HYDRAULIC SUPPLY AND RETURN.....	9-2
HYDRAULIC SYSTEM	
CONTAINER HANDLING ATTACHMENT (553)	
⇒S/N E019E-01809Z.....	11-96
CONTAINER HANDLING ATTACHMENT (555)	
⇒S/N E019E-01809Z.....	11-100
CONTAINER HANDLING ATTACHMENT (558)	
⇒S/N E019E-01809Z.....	11-104
SERIES 553	
250 MM (10 IN.) SIDE-SHIFT	
S/N E019E-01810Z⇒	11-98
SERIES 555	
S/N E019E-01810Z⇒.....	11-102
SERIES 558	
250 MM (10 IN.) SIDE-SHIFT	
S/N E019E-01810Z⇒	11-106
HYDRAULIC TANK AND ATTACHING PARTS	
⇒S/N E019E-01957A.....	9-10
S/N E019E-01958A⇒.....	9-12
HYDRAULIC VALVE AND ATTACHING PARTS	9-16

TABLE OF CONTENTS (Continued)

DESCRIPTION	PAGE
I	
IDLER GEAR	
TIER II ENGINE	2-78
IDLER SHAFT	5-20
INCHING PEDAL AND ACCESSORIES	
CAB	1-68
INCHING PEDAL LINKAGE	5-6
INDICATOR DISPLAY ASSEMBLY	1-76
INNER MAST	10-4
INSTALLATION	
EMPTY CONTAINER HANDLER	11-62
J	
JOYSTICK CONTROL	9-30
L	
LABELS	1-64
LIFT	10-6
LIFT ACCUMULATOR AND ATTACHING PARTS	9-6
LIFT CYLINDER	
EMPTY CONTAINER HANDLER	10-12
NON-EC	10-10
LIFT PUMP	
TIER I ENGINE	3-10
LIFT PUMP AND FUEL FILTER LINES	
TIER II ENGINE	3-20
LIFT PUMP ASSEMBLY	
TIER II ENGINE	3-22
LIFTING EYES	11-46
LOW PRESSURE SYSTEM	
TIER I ENGINE	3-8
LUBRICANT ARRANGEMENT	
TIER I ENGINE	2-48
M	
MAIN FRAME	
SERIES 553, 555, 558	
250 MM (10 IN.) SIDE-SHIFT	11-66
SERIES 555	
600 MM (23.6 IN.) SIDE-SHIFT	
S/N E019E-01810Z⇒	11-68
MANIFOLDS	
TIER I ENGINE	2-40
TIER II ENGINE	2-76
MAST AND REAR WORK LIGHTS	11-38
MAST INSTALLATION	9-38
MODULATOR VALVE	5-26
MONOTROL PEDAL	3-38

TABLE OF CONTENTS (Continued)

DESCRIPTION	PAGE
O	
OIL COOLER.....	8-10
OIL COOLER AND CONNECTIONS	
TIER II ENGINE.....	2-94
OIL FILTER	
TIER I ENGINE.....	2-38
OIL FILTER AND ATTACHING PARTS	
TIER II ENGINE.....	2-92
OIL PUMP AND DELIVERY HOUSING	
TIER II ENGINE.....	2-90
OIL SUMP	
TIER I ENGINE.....	2-34
TIER II ENGINE.....	2-74
OUTER MAST.....	10-2
OUTPUT GEAR.....	5-22
P	
PARK BRAKE	
WET BRAKE.....	6-28
PICK-UP SENSORS	
TIER II ENGINE.....	2-110
PILOT VALVE.....	9-24
PISTON AND CONNECTING ROD	
TIER II ENGINE.....	2-64
PUMP DRIVE GEARS.....	5-12
R	
ROTATING BEACON.....	11-42
S	
SEAT ASSEMBLY	
AIR.....	1-54
MECHANICAL.....	1-56
SELECTOR VALVE.....	11-30
SIDE-SHIFT CARRIAGE	
FOUR AND FIVE FUNCTION	
⇒S/N E019E-01950A.....	11-6
FOUR, FIVE, AND SIX FUNCTION	
S/N E019E-01951A⇒.....	11-10
INDIVIDUAL FORK POSITIONER	
FIVE FUNCTION	
S/N E019E-01951A⇒.....	11-18
⇒S/N E019E-01950A.....	11-14
SIMULTANEOUS FORK POSITIONER	
FOUR FUNCTION	
S/N E019E-01951A⇒.....	11-26
⇒S/N E019E-01950A.....	11-22
THREE FUNCTION.....	11-4
SIDE-SHIFT CYLINDER.....	11-36
SERIES 553, 558	
250 MM (10 IN.) SIDE-SHIFT.....	11-87

TABLE OF CONTENTS (Continued)

DESCRIPTION	PAGE
S (continued)	
SERIES 555	
600 MM (23.6 IN.) SIDE-SHIFT	
S/N E019E-01810Z⇒	11-88
SERIES 558	
250 MM (10 IN.) SIDE-SHIFT	
S/N E019E-01810Z⇒	11-89
STARTER MOTOR	
TIER I ENGINE	4-16
STEEL DOOR	
LEFT HAND	
S/N E019E02150B⇒	1-28
RIGHT HAND	
S/N E019E02150B⇒	1-26
STEERING COLUMN AND ATTACHING PARTS	7-4
STEERING COLUMN ASSEMBLY	7-8
STEERING CYLINDER	7-16
STEERING PUMP	
⇒D/B 09/2003	7-10
STEERING SYSTEM	7-2
T	
THERMOSTAT AND WATER OUTLET HOUSING	
TIER II ENGINE	2-96
THROTTLE LINKAGE	
PERKINS	3-32
THROTTLE PEDAL LINKAGE	
FORWARD AND REVERSE WITH AUTOSHIFT	3-34
MONOTROL PEDAL	3-36
TILT CYLINDER	9-28
CAB	1-34
TILT CYLINDER AND ATTACHING PARTS	9-26
TIMING CASE AND ALTERNATOR MOUNTING	
TIER II ENGINE	2-68
TIMING COVER	
TIER II ENGINE	2-70
TIMING GEAR	
TIER I ENGINE	2-30
TIER II ENGINE	2-72
TORQUE CONVERTER HOUSING	
PERKINS	5-2
TRAIL AXLE	7-12
TRAINING SEAT	1-62
TRANSMISSION	5-8
TRANSMISSION MOUNT AND ATTACHING PARTS	5-4
TURBO DRAIN PIPE AND BLANKING PLATE	
TIER II ENGINE	2-102
TURBOCHARGER	
TIER I ENGINE	2-44
TURBOCHARGER AND ATTACHING PARTS	

TABLE OF CONTENTS (Continued)

DESCRIPTION	PAGE
T (continued)	
TIER II ENGINE	2-100
TWIST LOCK CYLINDER	
SERIES 558	
250 MM (10 IN.) SIDE-SHIFT	11-86
TYRE AND WHEEL	
11.00 X 20	
14 PLY	11-50
12.00 X 20	
18 PLY	11-51
SOLID.....	11-52
V	
VALVE ASSEMBLY	
SERIES 553, 555, 558	
END BEAM	
S/N E019E-01810Z⇒	11-94
SIDE-SHIFT	11-90
SERIES 558	
END BEAM	
⇒S/N E019E-01809Z	11-92
VALVE COVER	
TIER I ENGINE	2-36
W	
WATER PUMP	
TIER I ENGINE	2-42
TIER II ENGINE	2-98
WATER SEPARATOR	3-26
WEAR PADS	
CONTAINER HANDLING ATTACHMENT (553, 555, 558).....	11-64
WINDOW WASHER AND ARMREST ASSEMBLY	1-80
WIRE HARNESS	
AUTOSHIFT BY-PASS.....	4-36
CAB SIDE CONSOLE	
⇒S/N E019E-01690Z.....	4-42
S/N E019E-01691Z⇒.....	4-46
CAB TILT.....	4-38
CAB UNDERFLOOR	4-40
CLOSED CAB.....	4-30
CLOSED CAB WITH ARMREST	4-32
OPEN CAB	4-28
OPEN CAB WITH ARMREST.....	4-34
REAR WIPER.....	4-26
STEERING COLUMN.....	4-24
TWO STAGE LIMITED FREE-LIFT.....	4-39
WIRING LOOMS	
TIER II ENGINE	2-108

SECTION 1
FRAME

DESCRIPTION	PAGE
AIR CONDITIONER	
PERKINS	1-42
AIR DUCT	
CAB.....	1-72
ARMREST	
PIVOT-UP	1-82
CAB AND ATTACHING PARTS	1-14
CAB AND TILT CYLINDER MOUNTING.....	1-30
CAB HARDWARE AND CONTROL COVER.....	1-66
CONDENSER.....	1-52
COUNTERWEIGHT	1-8
DASH DISPLAY	
CAB.....	1-74
DOOR	
GLASS.....	1-18
STEEL	
⇒S/N E019E02149B.....	1-22
ELECTRIC PUMP	1-38
FLOOR PLATES AND COVERS	
⇒S/N E019E01957A	1-10
S/N E019E01958A⇒	1-12
GENERAL TRUCK	1-2
HAND PUMP	
CAB TILT.....	1-36
HEATER AND AIR CONDITIONER.....	1-44
HEATER AND AIR CONDITIONER ASSEMBLY.....	1-50
HEATER AND AIR CONDITIONER ATTACHMENT	1-46
HEATER ARRANGEMENT	
PERKINS	1-40
HEATER ASSEMBLY	1-48
HOOD.....	1-4
HYDRAULIC CONTROL AND TWISTLOCK	
EMPTY CONATAINER HANDLER.....	1-78
INCHING PEDAL AND ACCESSORIES	
CAB.....	1-68
INDICATOR DISPLAY ASSEMBLY.....	1-76
LABELS.....	1-64
SEAT ASSEMBLY	
AIR.....	1-54
MECHANICAL	1-56
STEEL DOOR	
LEFT HAND	
S/N E019E02150B⇒.....	1-28
RIGHT HAND	
S/N E019E02150B⇒.....	1-26
TILT CYLINDER	
CAB.....	1-34
TRAINING SEAT	1-62
WINDOW WASHER AND ARMREST ASSEMBLY	1-80

GENERAL TRUCK (Figure 1-1)

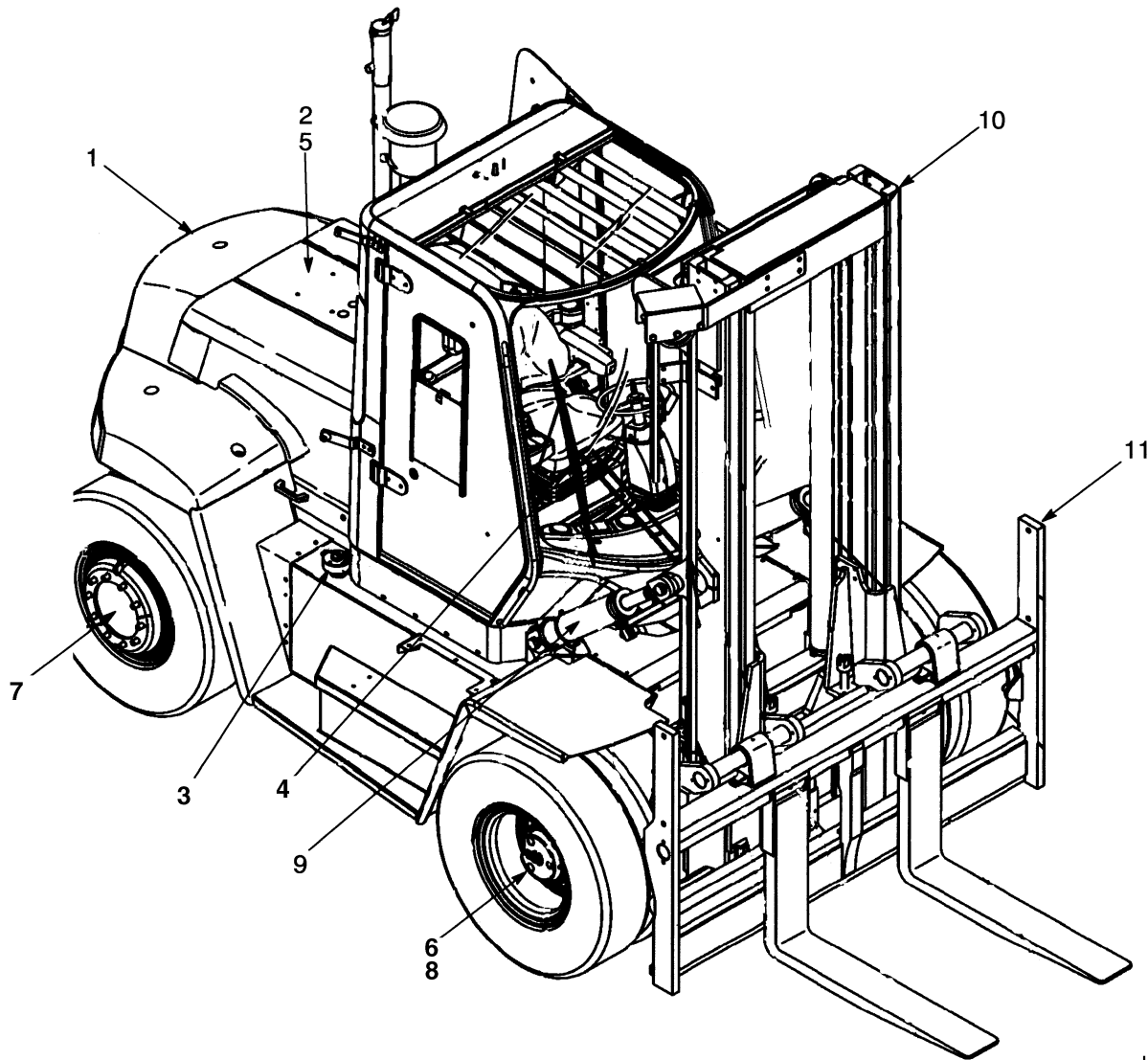

HP990022

ITEM	PART NO.	DESCRIPTION	QTY
1	Frame (☞ Figure 1-4)	1
2	Engine (☞ Figure 2-1)	1
3	Fuel System (☞ Figure 3-1)	1
4	Electrical System (☞ Figure 4-1)	1
5	Transmission (☞ Figure 5-4)	1
6	Drive Axle (☞ Figure 6-1)	1
7	Steering System (☞ Figure 7-1)	1
8	Brake System (☞ Figure 8-1)	1
9	Hydraulic System (☞ Figure 9-1)	1
10	Mast-Two Stage Limited Free-Lift (☞ Figure 10-1)	1
11	Optional (☞ Figure 11-1)	1
12	Numerical Index.....	1

HOOD (Figure 1-2)

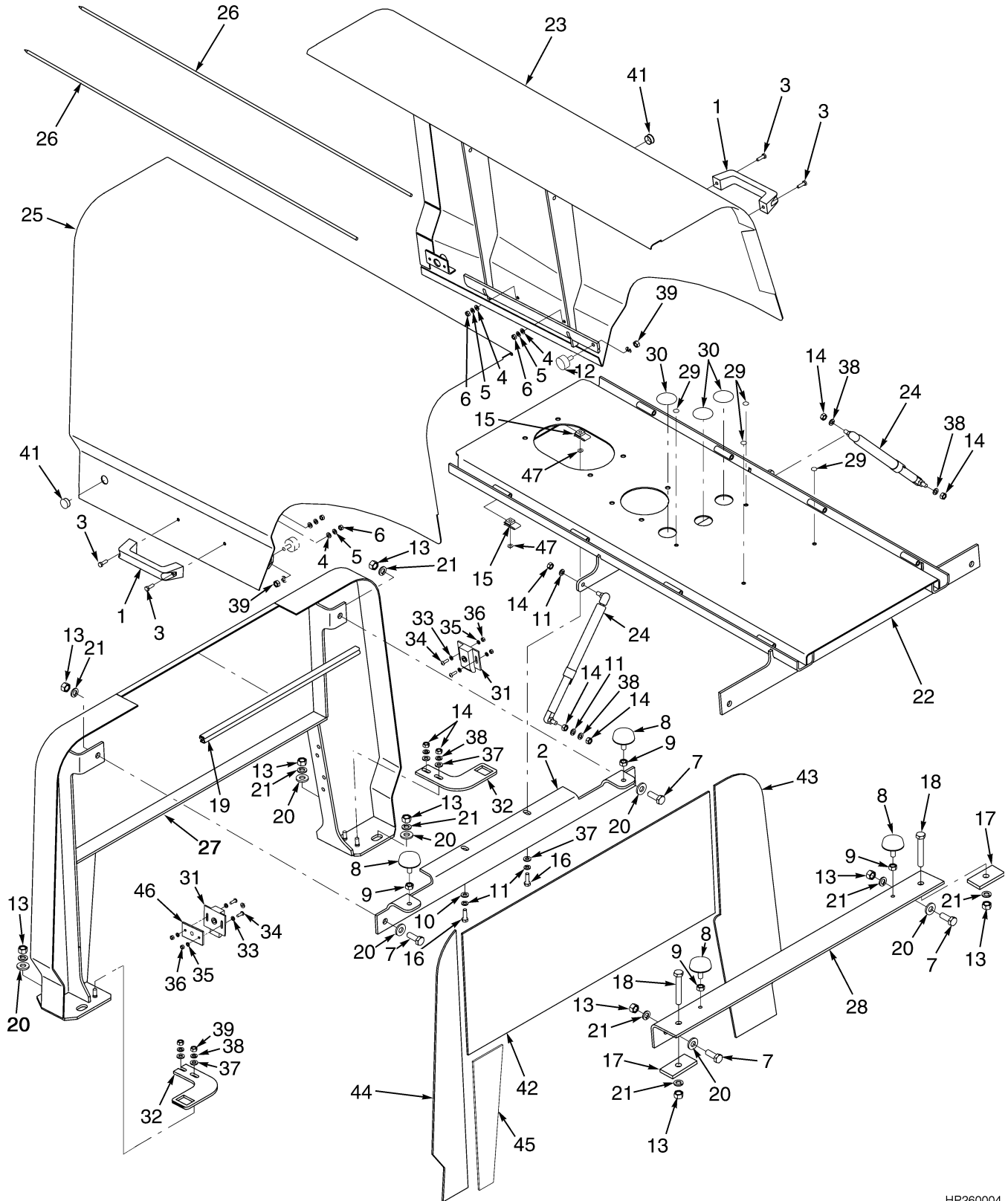

HP260004

HOOD

ITEM	PART NO.	DESCRIPTION	QTY
1	362030	Handle	2
2	1477508	Bracket.....	1
3	292501	Capscrew.....	4
4	320156	Washer	4
5	292680	Lockwasher.....	4
6	136687	Nut	4
7	292528	Capscrew.....	4
8	1479870	Screw (Stop).....	4
9	136692	Nut	4
10	320157	Washer	2
11	292681	Lockwasher.....	4
12	1489092	Screw (Stop).....	2
13	216877	Nut	10
14	239503	Nut	4
15	376397	Nut	2
16	18498	Capscrew.....	2
17	1479871	Washer	2
18	292535	Capscrew.....	AR
19	300088	Seal (Door) (Door)	8
20	320162	Washer	8
21	292683	Lockwasher.....	10
22	1554208	Channel	1
23	1476910	Hood (RH)	1
24	1385584	Gas Spring.....	2
25	1476911	Hood (LH).....	1
26	1478959	Rod	2
27	1489401	Support.....	1
28	1477512	Bracket.....	1
29	1494868	Plug (Without Air Conditioner)	4
30	1494869	Plug (Without Air Conditioner)	3
31	1382332	Latch	2
32	1494480	Bracket.....	2
33	320155	Washer	4
34	296155	Capscrew.....	4
35	292679	Lockwasher.....	4
36	292668	Nut	4
37	320160	Washer	4
38	292682	Lockwasher.....	4
39	136692	Nut	4
40	a 1382766	Wrench	1
41	309666	Plug (Non-EEC).....	2
42	b 1489402	Liner.....	1
43	b 1488424	Liner (RH).....	1
44	b 1488715	Liner (LH).....	1
45	b 1488716	Liner.....	1
46	1494642	Shim	AR
46	1494643	Shim	AR

HOOD

ITEM	PART NO.	DESCRIPTION	QTY
46	1494645	Shim	AR
47	320158	Washer	AR

FOOTNOTES:

- a Not Illustrated
- b ⇒ S/N E019E-01957A

COUNTERWEIGHT (Figure 1-3)

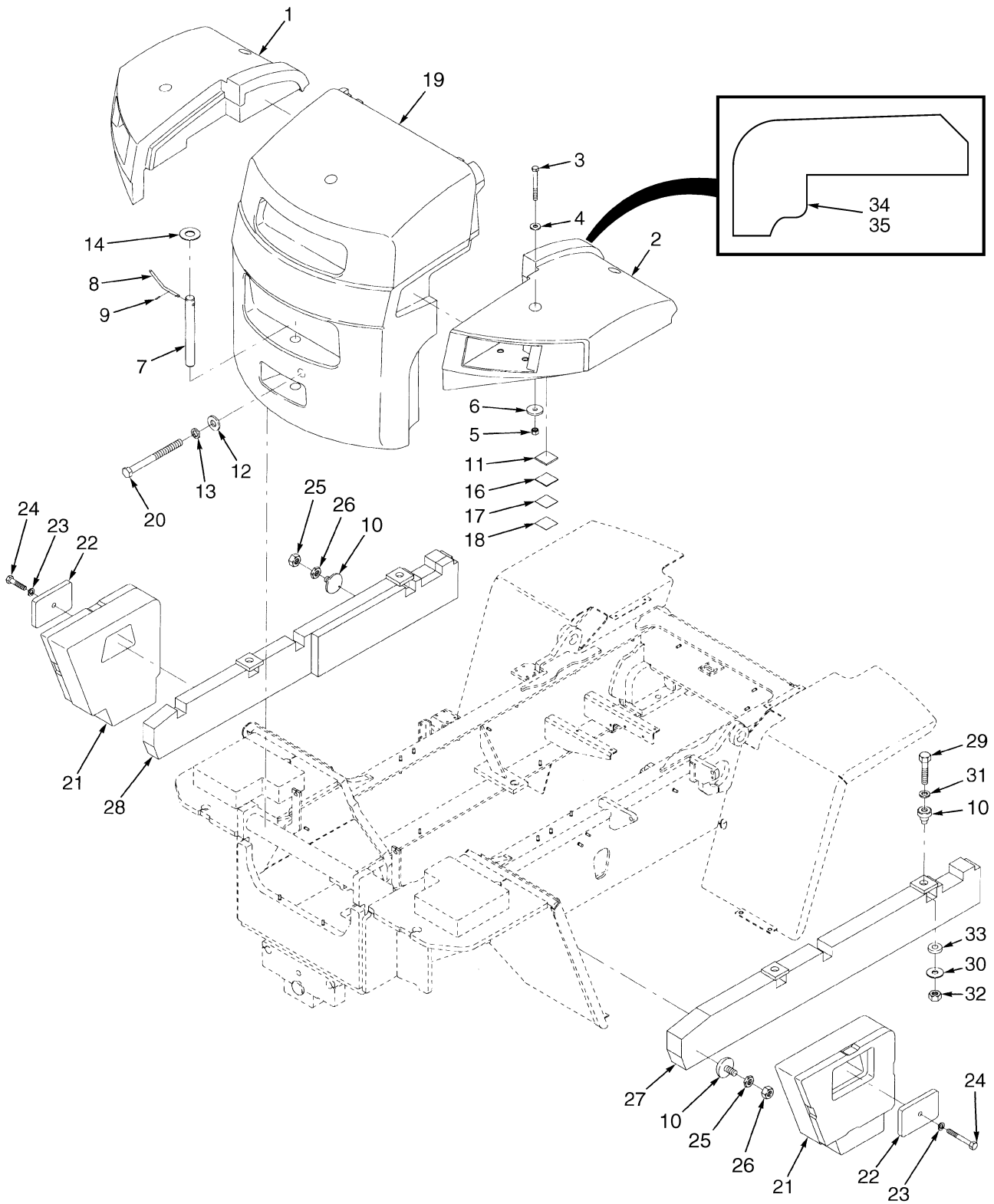

HP120578

COUNTERWEIGHT**KEY:****A: H13.00XM-14.00XM/H10.00-EC****B: H16.00XM/12.00-EC****C: H12.00-EC**

ITEM	PART NO.	DESCRIPTION	QTY		
			A	B	C
1	2038857	Fender (LH)	1	1	1
2	2038858	Fender (RH).....	1	1	1
3	292597	Capscrew.....	4	4	4
4	1475872	Washer	4	4	4
5	316829	Nut	4	4	4
6	1301086	Washer	4	4	4
7	1467696	Tow Pin	1	1	1
8	1495368	Grip.....	1	1	1
9	302440	Pin	1	1	1
10	816231	Stop	4
11	1475214	Shim	AR	AR	AR
12	221786	Washer	1	1	1
13	15170	Lockwasher.....	1	1	1
14	15189	Washer	1	1	1
15	280472	Sealant	AR	AR	AR
16	1475211	Shim	AR	AR	AR
17	1475212	Shim	AR	AR	AR
18	1475213	Shim	AR	AR	AR
19	1467625	Counterweight	1
19	1467626	Counterweight	1	1
20	1453469	Capscrew.....	1
20	1453470	Capscrew.....	..	1	1
21	2045338	Counterweight (RH).....	1	1	1
21	2045336	Counterweight (LH).....	1	1	1
22	1485676	Plate	2	2	2
23	292689	Lockwasher.....	2	2	2
24	292612	Capscrew (127 mm)	2	2	2
25	216877	Nut	4
26	296130	Nut	4
27	816136	Counterweight (RH).....	1
28	816137	Counterweight (LH).....	1
29	293696	Capscrew.....	4
30	816138	Washer	4
31	1331575	Washer	4
32	316828	Nut	4
33	1373270	Isolator.....	4
34	1532632	Liner (LH).....	1	1	1
35	1532633	Liner (RH).....	1	1	1

FLOOR PLATES AND COVERS (Figure 1-4) (⇒S/N E019E01957A)

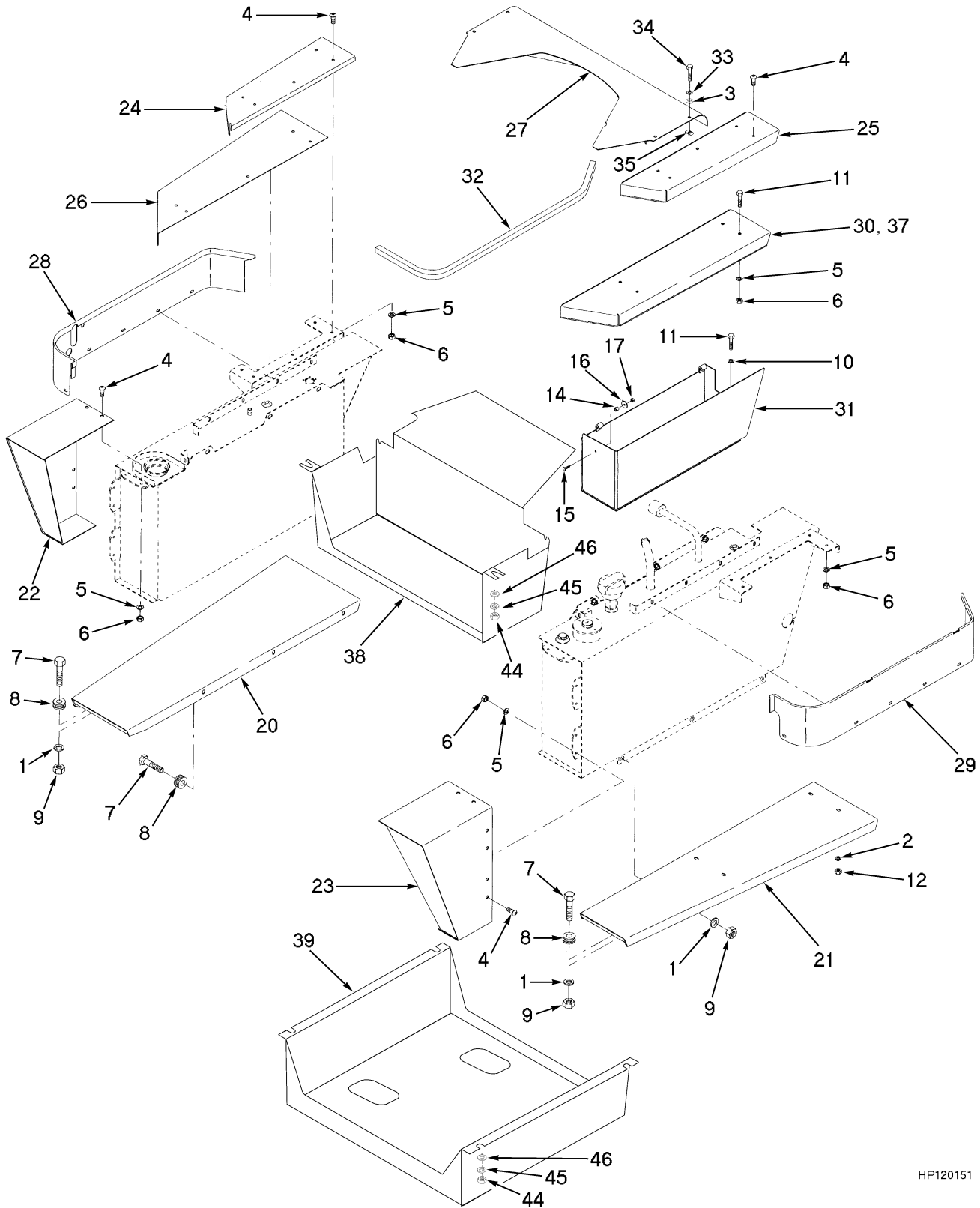

HP120151

FLOOR PLATES AND COVERS
(⇒S/N E019E01957A)

ITEM	PART NO.	DESCRIPTION	QTY
1	320162	Washer	46
2	292683	Lockwasher.....	3
3	292681	Lockwasher.....	3
4	296173	Capscrew.....	15
5	292682	Lockwasher.....	30
6	292655	Nut	30
7	246001	Capscrew.....	20
8	216735	Grommet.....	20
9	300937	Locknut	20
10	320160	Washer	8
11	287854	Capscrew.....	8
12	136692	Nut	8
13	16257	Screw.....	1
14	1335831	Bushing.....	1
15	287816	Capscrew.....	1
16	1335832	Washer	1
17	313805	Nut	1
18	288762	Tape (Foam)	AR
19	1319189	Spring (Latch).....	1
20	1472661	Running Board (LH).....	1
21	1472665	Running Board (RH).....	1
22	1483977	Extension.....	1
23	1484061	Extension.....	1
24	1475488	Step	1
25	1475489	Step	1
26	1477099	Step	1
27	1485265	Cover	1
28	1485263	Panel (LH).....	1
29	1485264	Panel (RH).....	1
30	1471294	Cover (Battery Box).....	1
31	1471296	Battery Box	1
32	1491360	Seal	AR
33	320158	Washer	14
34	296167	Capscrew.....	14
35	1480237	Clip Nut.....	14
36	a 375295	Trim	AR
37	1494649	Step	1
38	1515432	Cover (Rear)	1
39	1515434	Cover (Bottom)	1
40	1516039	Liner.....	1
41	1516040	Liner.....	1
42	1516041	Liner.....	1
43	1516042	Liner.....	1
44	136692	Nut	8
45	292682	Lockwasher.....	8
46	320160	Washer	8

FOOTNOTES:**a** Not Illustrated

FLOOR PLATES AND COVERS (Figure 1-5) (S/N E019E01958A⇒)

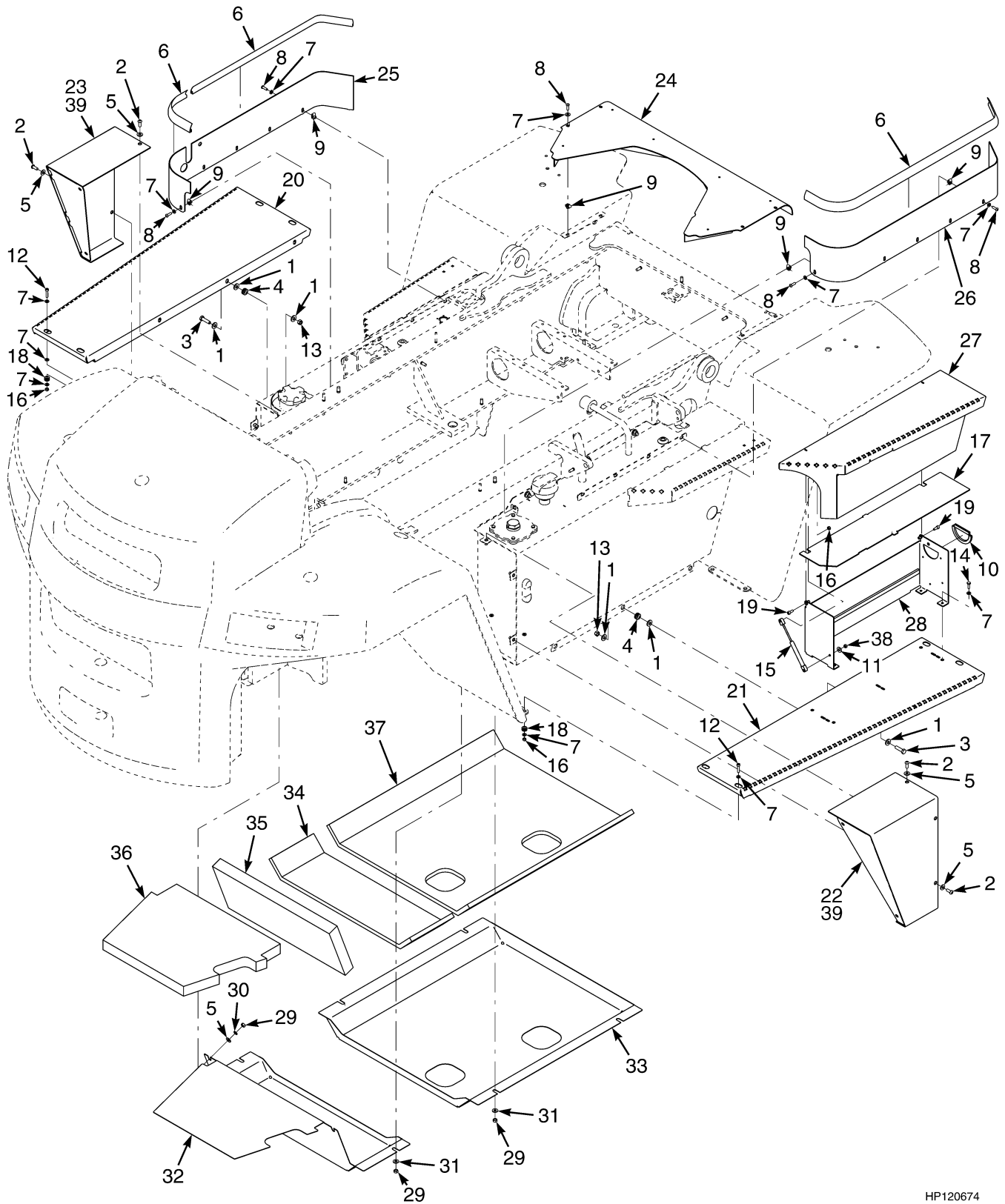

HP120674

FLOOR PLATES AND COVERS

(S/N E019E01958A⇒)

ITEM	PART NO.	DESCRIPTION	QTY
1	320162	Washer	18
2	296173	Capscrew.....	6
3	287837	Capscrew.....	6
4	216735	Grommet.....	6
5	320160	Washer	6
6	1491360	Seal	AR
7	320158	Washer	42
8	296167	Capscrew.....	14
9	1480237	Clip Nut.....	14
10	325983	Trim	AR
11	292681	Lockwasher.....	2
12	296012	Capscrew.....	8
13	302402	Nut	6
14	136749	Capscrew.....	4
15	1532341	Gas Spring.....	1
16	302400	Locknut	10
17	2071326	Cover	1
18	91946	Grommet.....	8
19	1529665	Capscrew.....	2
20	1529664	Running Board (LH).....	1
21	1529663	Running Board (RH)	1
22	1532449	Extension (LH)	1
23	1532447	Extension (RH)	1
24	1485265	Cover	1
25	1485263	Panel (LH).....	1
26	1485264	Panel (RH)	1
27	1529751	Cover (Battery Box)	1
28	1532202	Battery Box	1
29	a 136692	Nut	8
30	a 292682	Lockwasher.....	8
31	a 320160	Washer	8
32	a 1515432	Cover (Rear)	1
33	a 1562201	Cover (Bottom)	1
34	a 1562209	Liner.....	1
35	a 1562210	Liner.....	1
36	a 1562212	Liner.....	1
37	a 1562205	Liner.....	1
38	329069	Nut	2
39	288762	Tape.....	AR

FOOTNOTES:

a H13.00XM-6, H14.00XM-6, H16.00XM-6

CAB AND ATTACHING PARTS (Figure 1-6)

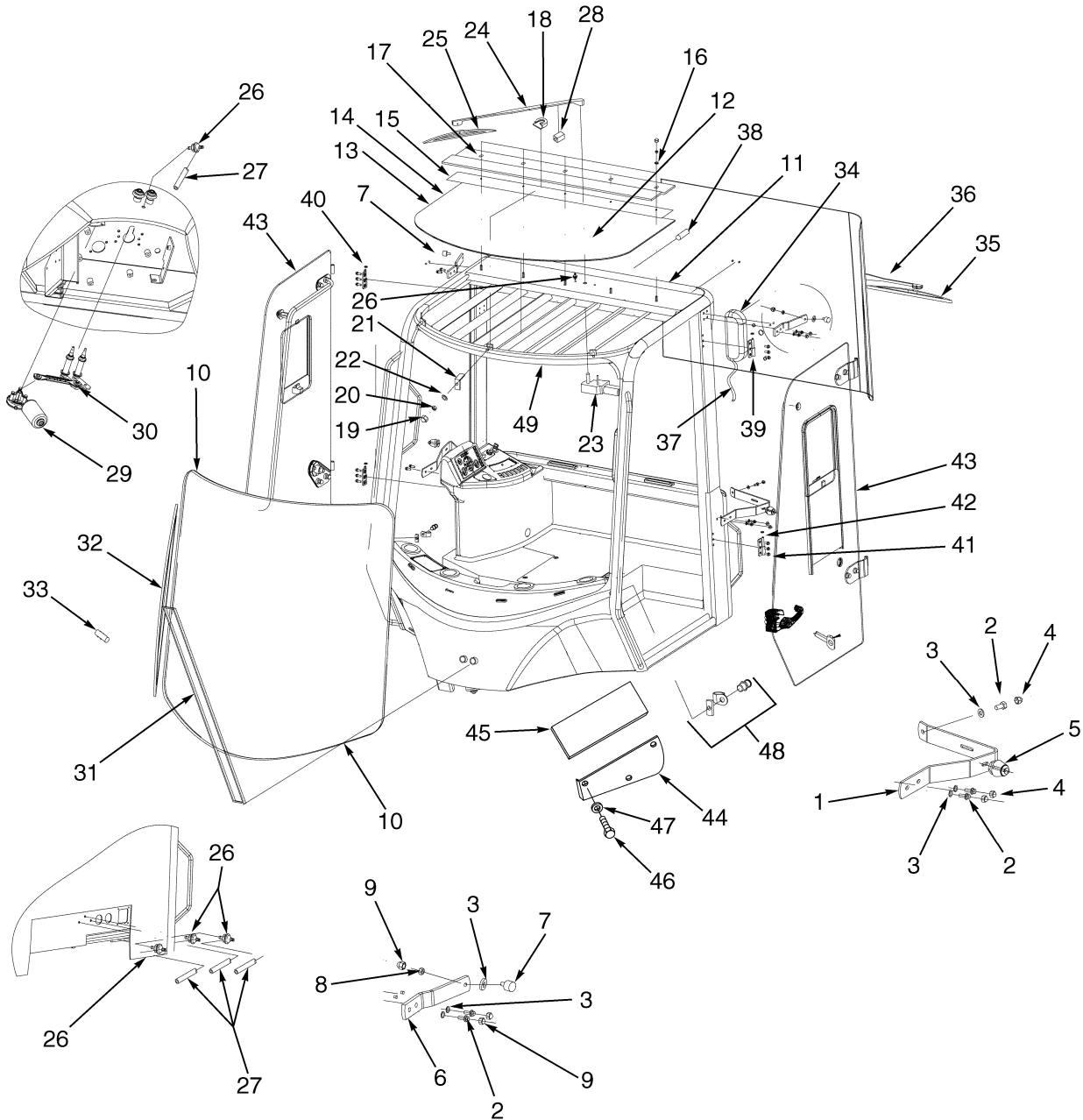

HP120624

CAB AND ATTACHING PARTS

ITEM	PART NO.	DESCRIPTION	QTY
1	1493310	Bar (Hold-Open)	2
2	1492239	Bolt	8
3	320158	Washer	10
4	1476584	Cap	6
5	1493313	Bumper	2
6	1493315	Bar (Hold-Open) (Bumper)	2
7	1493316	Bumper	2
8	316835	Nut	2
9	1476584	Cap	6
10	Window Assembly (Curved Front)	1
10	1493320	Window (Tempered)	1
10	1498750	Seal Kit	1
10	2046118	Windshield (Service Option)	1
10	1498750	Seal Kit	1
10	2046119	Flat Glass Kit (Service Option)	1
10	1498750	Seal Kit	1
10	1493278	Mirror (Interior)	1
11	Window Assembly (Rear)	1
11	1493324	Window (Rear) (Curved)	1
11	1498750	Seal Kit	1
12	1558024	Window (Skylight) (Laminated)	1
13	1515337	Seal	AR
13	1393463	Seal (Optional)	AR
14	1498339	Sealant	AR
15	1498341	Seal	1
16	1498342	Washer	5
17	1493328	Clip	1
18	1493329	Cover	3
19	1493397	Cover	8
20	316834	Nut	8
21	1498343	Clip	3
22	320156	Washer	3
23	1493344	Wiper Motor	1
24	1498347	Wiper Arm	1
25	1498348	Wiper Blade	1
26	1493336	Connector	6
27	1493337	Hose	9
28	1507003	Nozzle (Top)	1
29	1493332	Wiper Motor	1
30	1493333	Linkage	1
31	1493334	Wiper Arm	1
32	1493335	Wiper Blade	1
33	1507005	Nozzle (Front)	1
34	1493339	Wiper Motor	1
35	1493340	Wiper Blade	1
36	1493341	Wiper Arm	1
37	1493342	Wire Harness (Rear Wiper)	1
38	1498344	Washer (Nozzle)	1
39	1393473	Hinge (LH)	2
39	Pin (Hinge)	2
40	1393474	Hinge (RH)	2

CAB AND ATTACHING PARTS

ITEM	PART NO.	DESCRIPTION	QTY
40	Pin (Hinge)	2
41	1493308	Bolt	12
42	1468312	Washer	4
43	1493347	Door Assembly (Glass) (LH) (☞ Figure 1-7)	1
43	1493348	Door Assembly (Glass) (RH) (☞ Figure 1-7)	1
43	a 1480218	Door Assembly (LH) (Steel) (☞ Figure 1-8)	1
43	a 1480219	Door Assembly (RH) (Steel) (☞ Figure 1-8)	1
43	b 1553405	Door Assembly (LH) (Steel) (☞ Figure 1-10)	1
43	b 1553404	Door Assembly (RH) (Steel) (☞ Figure 1-9)	1
44	1493272	Air Filter Cover	1
44	1493274	Cover	1
45	1493276	Air Filter	1
46	293613	Capscrew	3
47	320156	Washer	3
48	1493318	Bolt Assembly (Striker)	2
48	1504953	Block	1
48	1504954	Guard (Striker Bolt)	1
48	1504955	Bolt (Striker)	1
49	1493307	Frame (Cab)	1
	1493309	Mounting (Hold-Open) (Includes Items 1-5, 48)	1
	1493314	Bumper (Hold-Open) (Includes Items 2-3, 6-9)	1
	1493325	Glass Assembly (Roof) (Includes Items 15-22)	1
	1493343	Wiper System (Roof) (Includes Items 23-28)	1
	1493331	Wiper System (Front) (Includes Items 26-27, 29-33)	1
	1493338	Wiper System (Rear) (Includes Items 26-27, 34-38)	1

FOOTNOTES:

a ⇒ S/N E019E02149B

b S/N E019E02150B ⇒

DOOR (Figure 1-7) GLASS

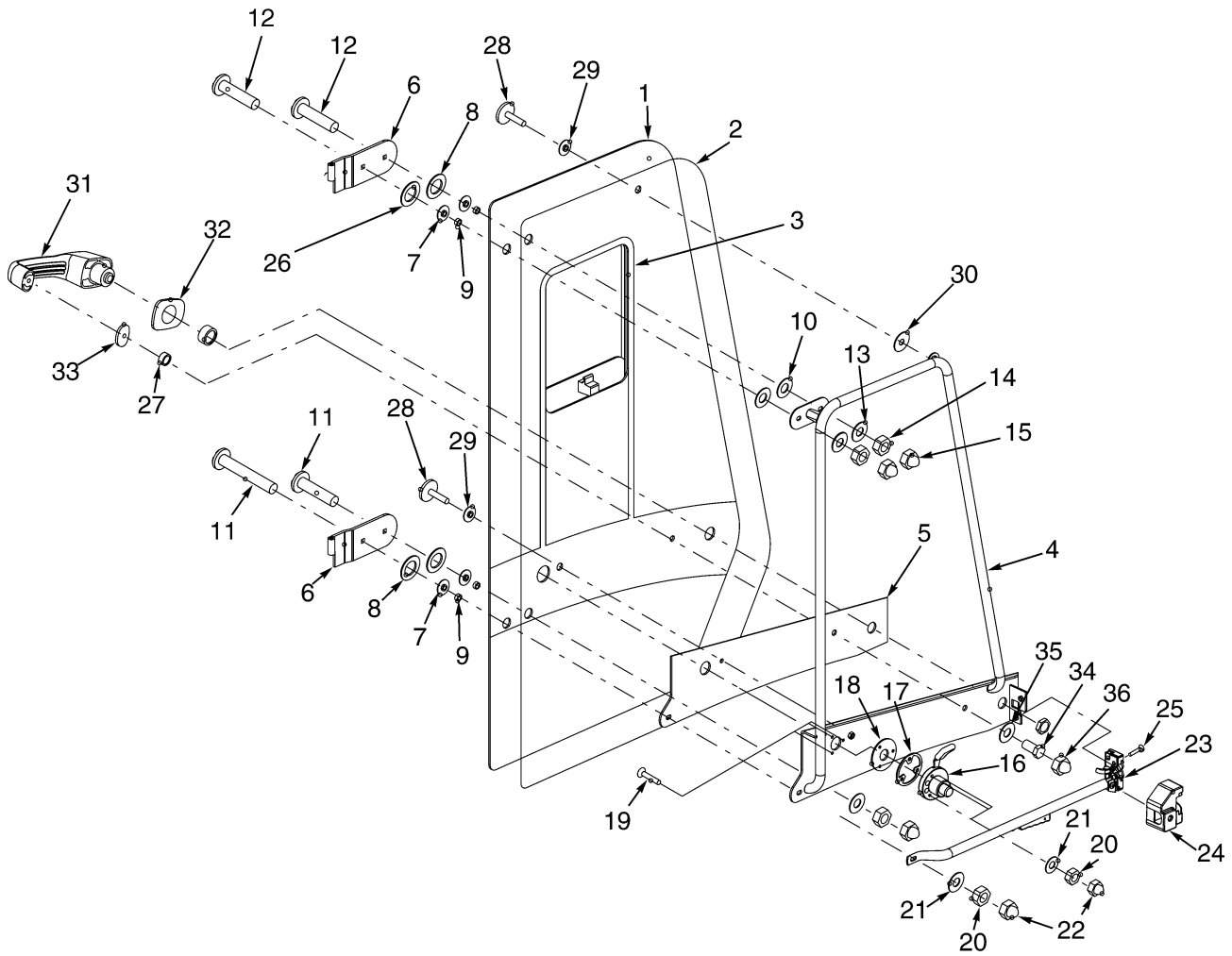

HP120612

**DOOR
GLASS****KEY:****A: Right Hand****B: Left Hand**

ITEM	PART NO.	DESCRIPTION	QTY	
			A	B
	1493348	Door Assembly (Glass).....	1	..
	1507006	Key.....	1	..
	1493347	Door Assembly (Glass).....	..	1
	1507006	Key.....	..	1
1	1510214	Door (Glass).....	1	..
1	1510213	Door (Glass).....	..	1
2	1495441	Seal.....	AR	AR
3	1495442	Sliding Window.....	4	4
3	1483226	Latch.....	1	1
3	1542547	Plate.....	1	1
3	1542548	Shim (Rubber).....	1	1
3	1542549	Screw.....	2	2
4	1495464	Frame.....	1	..
4	1495443	Frame.....	..	1
5	1495465	Gasket.....	1	..
5	1495444	Gasket.....	..	1
6	1497240	Door Hinge.....	1	..
6	1495446	Door Hinge.....	..	1
7	1495447	Washer.....	4	4
8	1495448	Washer.....	4	4
9	1495449	Bushing.....	4	4
10	1495450	Washer.....	2	2
11	1495451	Screw.....	1	1
12	1495452	Screw.....	3	3
13	320160	Washer.....	4	4
14	1493501	Nut.....	4	4
15	1493312	Cap.....	4	4
16	1497241	Hold-Open.....	1	..
16	1495453	Hold-Open.....	..	1
17	1495456	Washer.....	1	1
18	1495454	Seal.....	1	1
19	1495455	Screw.....	3	3
20	316834	Nut.....	3	3
21	320156	Washer.....	3	3
22	1493397	Cover.....	3	3
23	1495434	Latch And Handle.....	1	..
23	1495437	Latch And Handle.....	..	1
24	1495435	Cover.....	1	..
24	1495438	Cover.....	..	1
25	296229	Capscrew.....	2	2
26	1495459	Bushing.....	1	1
27	1495460	Bushing.....	1	1
28	1495462	Bolt.....	2	2
29	1495463	Washer.....	2	2
30	1468316	Washer.....	1	1
31	1495371	Handle (Push Button).....	1	1

DOOR GLASS

ITEM	PART NO.	DESCRIPTION	QTY	
			A	B
32	1495372	Seal	1	1
33	1495431	Seal	1	1
34	1495432	Bolt	1	1
35	1468321	Washer	1	1
36	1493397	Cover	1	1
	1495436	Latch Assembly (Includes Items 23-30).....	1	..
	1495439	Latch Assembly (Includes Items 23-30).....	..	1
	1495433	Push Button Handle Assembly (Includes Items 31-36)	1	1

DOOR (Figure 1-8) STEEL (⇒S/N E019E02149B)

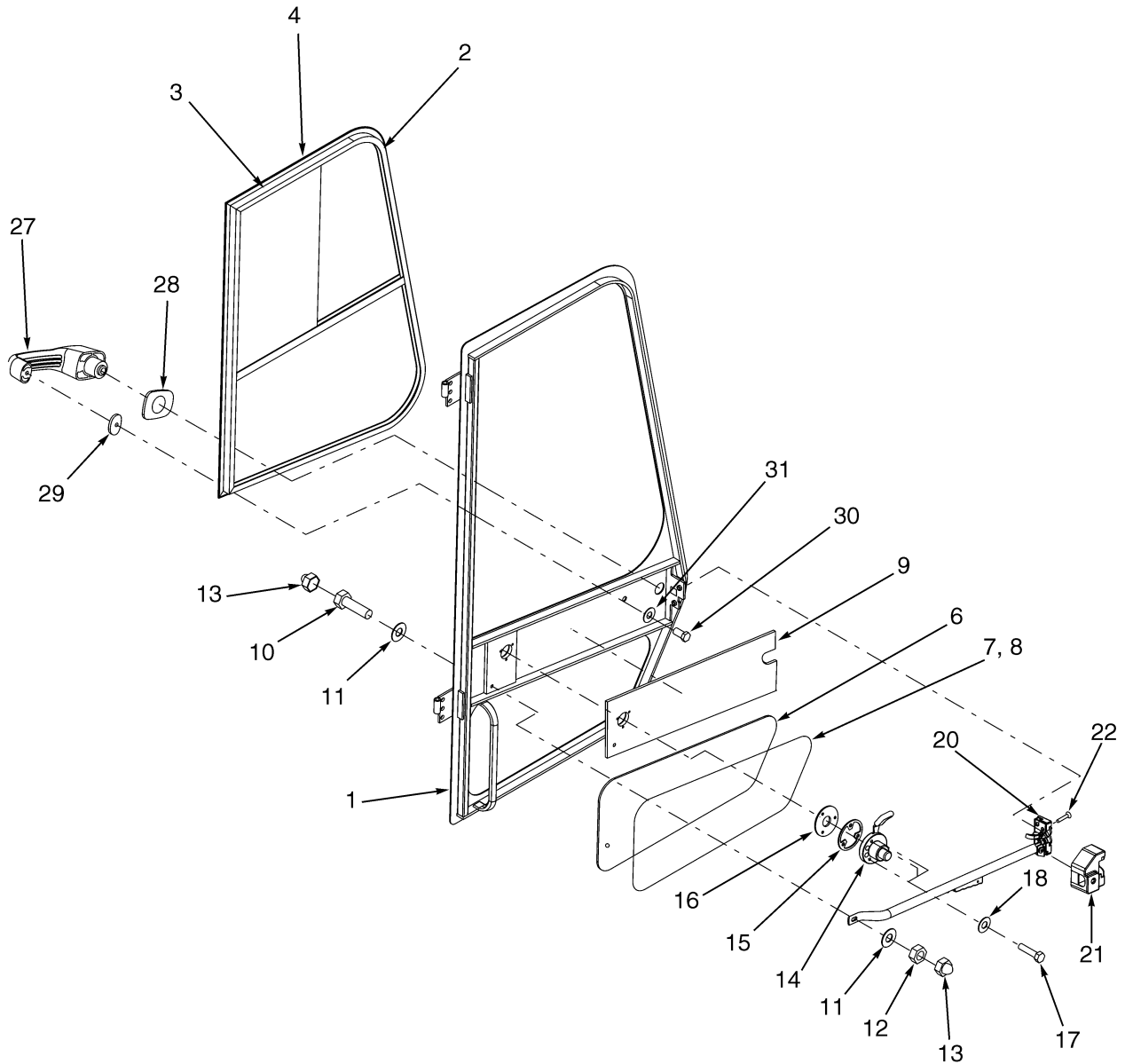

HP120629

**DOOR
STEEL
(⇒S/N E019E02149B)**

KEY:**A: Right Hand****B: Left Hand**

ITEM	PART NO.	DESCRIPTION	QTY	
			A	B
	1480218	Door Assembly (LH)	1
	1507006	Key.....	..	1
	1480219	Door Assembly (RH).....	1	..
	1507006	Key.....	1	..
1	1506803	Frame	1	..
1	1506798	Frame	1
1	1515337	Seal	AR	AR
2	1506804	Sliding Window.....	1	..
2	1506799	Sliding Window.....	..	1
3	1393476	Activator	4	4
4	1393477	Primer.....	AR	AR
5	a 1393475	Glue.....	AR	AR
6	1506800	Window (Door)	1	1
7	1506801	Terminal.....	AR	AR
8	1393466	Seal	AR	AR
9	1506805	Encasement (Door)	1	..
9	1506802	Encasement (Door)	1
10	287854	Capscrew	1	1
11	320160	Washer	2	2
12	1493501	Nut.....	1	1
13	1493312	Cap.....	2	2
14	1497241	Hold-Open	1	..
14	1495453	Hold-Open	1
15	1495456	Washer	1	1
16	1495454	Seal	1	1
17	1495432	Bolt	3	3
18	320156	Washer	3	3
19	a 1507006	Key	1	1
20	1495434	Latch And Handle.....	1	..
20	1495437	Latch And Handle.....	..	1
21	1495435	Cover.....	1	..
21	1495438	Cover.....	..	1
22	296229	Capscrew	2	2
23	a 1495459	Bushing	1	1
24	a 1495460	Bushing	1	1
25	a 1495462	Bolt	2	2
26	a 1495463	Washer	2	2
27	1495371	Handle (Push Button).....	1	1
28	1495372	Seal	1	1
29	1495431	Seal	1	1
30	1495432	Bolt	1	1
31	1468321	Washer	1	1
	1495433	Push Button Handle Assembly (Includes Items 27-31)	1	1

Thank you so much for reading.
Please click the “Buy Now!”
button below to download the
complete manual.



After you pay.

You can download the most
perfect and complete manual in
the world immediately.

Our support email:

ebooklibonline@outlook.com