

PARTS MANUAL

FORTENS

**H1.6-1.8FT, H2.0FTS
(F001)**

CUSTOMER EDITION

HYSTER

SECTIONS

1	FRAME
2	ENGINES
3	FUEL SYSTEM
4	ELECTRICAL SYSTEM
5	TRANSMISSION
6	DRIVE AXLE
7	STEERING SYSTEM
8	BRAKE SYSTEM
9	HYDRAULIC SYSTEM
10	MAST-TWO STAGE LIMITED FREE-LIFT
11	MAST-TWO STAGE FULL FREE-LIFT
12	MAST-THREE STAGE FULL FREE-LIFT
13	OPTIONS
14	NUMERICAL INDEX

TABLE OF CONTENTS

DESCRIPTION	PAGE
A	
AIR CLEANER FILTER ASSEMBLY	
LPG AND DIESEL	3-8
AIR CLEANER SYSTEM	
DIESEL	3-4
MAZDA 2.0L	3-2
ALTERNATOR AND MOUNTING	
YANMAR 2.6L DIESEL	4-24
AUXILIARY TUBE EXTENSIONS	
TWO STAGE FULL FREE-LIFT AND THREE STAGE FULL FREE-LIFT.....	13-18
TWO STAGE LIMITED FREE-LIFT.....	13-16
AUXILIARY ONE SECTION	
ELECTRONIC CONTROL	
THREE AND FOUR FUNCTION.....	9-34
AUXILIARY SECTIONS, ONE AND TWO	
MANUAL CONTROL VALVE	
THREE AND FOUR FUNCTION.....	9-22
AUXILIARY TWO SECTION	
ELECTRONIC CONTROL	
FOUR FUNCTION.....	9-36
B	
BACK-UP ALARM	13-2
BRAKE ASSEMBLY	8-6
BRAKE LINKAGE	
DUAL PEDAL.....	8-4
SINGLE PEDAL.....	8-2
C	
CAMSHAFT AND DRIVE GEAR	
YANMAR 2.6L DIESEL	2-48
CAMSHAFT AND VALVES	
MAZDA 2.0L	2-26
CARRIAGE	
THREE STAGE FULL FREE-LIFT	12-20
TWO STAGE FULL FREE-LIFT	11-16
TWO STAGE LIMITED FREE-LIFT.....	10-12
CONTROL LEVER LABELS.....	1-26
CONTROL VALVE	
TRANSMISSION.....	5-16
CONTROL VALVE ASSEMBLY	
ELECTRONIC CONTROL	
THREE AND FOUR FUNCTION.....	9-26
MANUAL CONTROL	
THREE AND FOUR FUNCTION.....	9-18
COOLING	
MAZDA 2.0L	
LPG	2-6
YANMAR 2.6L DIESEL	2-32
COUNTERWEIGHT	1-10
COWL ELECTRICAL.....	4-12

TABLE OF CONTENTS (Continued)

DESCRIPTION	PAGE
C (continued)	
COWL MOUNTING	1-8
CRANKSHAFT AND PISTONS	
MAZDA 2.0L	2-28
YANMAR 2.6L DIESEL	2-50
CYLINDER BLOCK	
MAZDA 2.0L	2-30
YANMAR 2.6L DIESEL	2-52
CYLINDER HEAD	
MAZDA 2.0L	2-24
YANMAR 2.6L DIESEL	2-46
D	
DISTRIBUTER	
MAZDA 2.0L	4-23
DRIVE AXLE	6-2
DRIVE TIRES AND WHEELS	6-5
PNEUMATIC RADIAL	6-6
E	
ELECTRICAL SYSTEM	
CHASSIS	4-2
ELECTRO HYDRAULIC POPPET VALVE	
ELECTRONIC CONTROL	
HOIST AND LOWER	9-32
ELECTRONIC LEVER LABELS	1-28
ENGINE ELECTRICAL COMPONENTS	
MAZDA 2.0L	4-4
ENGINE ELECTRICAL SYSTEM	
MAZDA 2.0L	
LPG	4-6
YANMAR 2.6L DIESEL	4-8
ENGINE FUEL SYSTEM AND EMISSION CONTROL	
MAZDA 2.0L	2-14
ENGINE MOUNTING	2-2
EXHAUST	
MAZDA 2.0L	
WITH CATALYTIC CONVERTER	2-8
WITHOUT CATALYTIC CONVERTER	2-10
WITH PURIFIER	
YANMAR 2.6L DIESEL	2-34
WITHOUT PURIFIER	
YANMAR 2.6L DIESEL	2-36
F	
FAN ASSEMBLY	2-4
FENDER EXTENSIONS AND MUD GUARDS	
WITH WIDE TREAD	1-6
FIRE EXTINGUISHER	13-5
FLOORPLATES AND COVERS	1-4

TABLE OF CONTENTS (Continued)

DESCRIPTION	PAGE
F (continued)	
FLYWHEEL AND HOUSING	
MAZDA 2.0L	2-16
YANMAR 2.6L DIESEL	2-40
FORKS	1-32
FORWARD CLUTCH	
INPUT	5-12
FREE LIFT CYLINDER	
TWO STAGE FULL FREE-LIFT	11-14
FREE-LIFT	
THREE STAGE FULL FREE-LIFT	12-16
TWO STAGE FULL FREE-LIFT	11-12
FREE-LIFT CYLINDER	
THREE STAGE FULL FREE-LIFT	12-18
FUEL FILTER	
YANMAR 2.6L DIESEL	3-18
FUEL INJECTION	
YANMAR 2.6L DIESEL	3-20
FUEL SYSTEM	
DIESEL	3-16
MAZDA 2.0L	3-10
FULL SUSPENSION SEAT	
WITH AND WITHOUT ELECTRONIC CONTROLS	1-18
FULL SUSPENSION SWIVEL SEAT	
WITH AND WITHOUT ELECTRONIC CONTROLS	1-20
G	
GEAR HOUSING	
YANMAR 2.6L DIESEL	2-42
GEAR PUMP	
MAZDA 2.0L	9-4
YANMAR DIESEL	9-5
H	
HAND LEVERS	
FOUR FUNCTION	
WITH DETENTED LEVERS.....	9-16
WITHOUT DETENTED LEVERS	9-14
THREE FUNCTION	
WITH DETENTED LEVERS.....	9-12
WITHOUT DETENTED LEVERS	9-10
HEADER HOSE	
THREE STAGE FULL FREE-LIFT	12-22
TWO STAGE FULL FREE-LIFT	11-18
HEADER HOSES	
TWO STAGE LIMITED FREE-LIFT	10-14
HOOD.....	1-2
HYDRAULIC FILTER	9-6
HYDRAULIC SUPPLY AND RETURN.....	9-2

TABLE OF CONTENTS (Continued)

DESCRIPTION	PAGE
I	
INNER MAST	
THREE STAGE FULL FREE-LIFT	12-6
TWO STAGE FULL FREE-LIFT	11-4
TWO STAGE LIMITED FREE-LIFT	10-4
INSTRUMENT CLUSTER	4-15
INTAKE AND EXHAUST MANIFOLDS	
MAZDA 2.0L	2-12
YANMAR 2.6L DIESEL	2-38
INTEGRAL SIDE-SHIFT ASSEMBLY	
TWO AND THREE STAGE FULL FREE-LIFT	13-10
TWO STAGE LIMITED FREE-LIFT	13-8
INTEGRAL SIDE-SHIFT CYLINDER	13-12
INTEGRAL SIDE-SHIFT HYDRAULIC HOSES	
TWO AND THREE STAGE FULL FREE-LIFT	13-14
TWO STAGE LIMITED FREE-LIFT	13-13
INTERMEDIATE MAST	
THREE STAGE FULL FREE-LIFT	12-4
J	
JOY STICK AND	
ELECTRONIC CONTROL LEVERS	4-16
JOYSTICK LABELS	1-30
L	
LABELS	
EXTERIOR	1-22
INTERIOR	1-24
LOAD BACKREST EXTENSION	1-34
LPG TANK BRACKET	
SWING OUT	3-12
SWING OUT/DROP DOWN	3-14
LUBE SYSTEM	
YANMAR 2.6L DIESEL	2-56
M	
MAIN LIFT	
THREE STAGE FULL FREE-LIFT	12-8
TWO STAGE FULL FREE-LIFT	11-6
TWO STAGE LIMITED FREE-LIFT	10-6
MAIN LIFT CYLINDER	
LEFT HAND	
THREE STAGE FULL FREE-LIFT	12-14
TWO STAGE FULL FREE-LIFT	11-10
TWO STAGE LIMITED FREE-LIFT	10-10
RIGHT HAND	
THREE STAGE FULL FREE-LIFT	12-12
TWO STAGE FULL FREE-LIFT	11-8
TWO STAGE LIMITED FREE-LIFT	10-8
MAST ELECTRICAL	

TABLE OF CONTENTS (Continued)

DESCRIPTION	PAGE
M (continued)	
TILT SENSOR.....	4-22
MAST INSTALLATION.....	9-40
MIRRORS.....	13-4
MONOTROL PEDAL	3-26
N	
NON SUSPENSION SEAT WITHOUT ELECTRONIC CONTROLS	1-14
O	
OIL PAN YANMAR 2.6L DIESEL	2-44
OIL PUMP AND FILTER MAZDA 2.0L	2-22
OUTER MAST THREE STAGE FULL FREE-LIFT	12-2
TWO STAGE FULL FREE-LIFT	11-2
TWO STAGE LIMITED FREE-LIFT.....	10-2
OUTLET SECTION ELECTRONIC CONTYROL THREE AND FOUR FUNCTION.....	9-38
MANUAL CONTROL VALVE THREE AND FOUR FUNCTION.....	9-24
OVERHEAD GUARD.....	1-12
P	
PARK BRAKE.....	8-8
POWER DISTRIBUTION MODULE	4-14
PRE-CLEANER AND MOUNT	3-6
R	
REVERSE CLUTCH COUNTER.....	5-14
S	
SEMI SUSPENSION SEAT WITH AND WITHOUT ELECTRONIC CONTROLS	1-16
STEER TIRES AND WHEELS	7-12
STEERING AXLE.....	7-8
STEERING COLUMN ASSEMBLY.....	7-4
STEERING CONTROL UNIT	7-6
STEERING CYLINDER.....	7-10
STEERING SYSTEM	7-2
T	
THROTTLE LINKAGE MAZDA 2.0L	3-22
YANMAR DIESEL	3-24
TILT AND AUXILIARY HOSES.....	9-8

TABLE OF CONTENTS (Continued)

DESCRIPTION	PAGE
T (continued)	
TILT CYLINDERS	
LEFT HAND.....	9-44
RIGHT HAND.....	9-42
TILT SECTION	
ELECTRONIC CONTROL	
THREE AND FOUR FUNCTION.....	9-30
TIMING GEAR COVER AND OIL PAN	
MAZDA 2.0L.....	2-20
TORQUE CONVERTER.....	5-3
TRANSMISSION	
SINGLE SPEED	
SHEET 1 OF 2.....	5-8
SHEET 2 OF 2.....	5-10
TRANSMISSION COOLING	
MAZDA 2.0L.....	5-4
YANMAR 2.6L DIESEL.....	5-6
TRANSMISSION ELECTRICAL SYSTEM.....	4-20
TRANSMISSION MOUNT.....	5-2
V	
VALVE ASSEMBLY, LIFT AND LOWER	
ELECTRONIC CONTROL VALVE	
THREE AND FOUR FUNCTION.....	9-28
VALVE ASSEMBLY, LIFT AND TILT	
MANUAL CONTROL VALVE	
THREE AND FOUR FUNCTION.....	9-20
W	
WATER PUMP	
MAZDA 2.0L.....	2-18
YANMAR 2.6L DIESEL.....	2-54
WIRE HARNESS	
BACK-UP ALARM.....	13-6
CHASSIS	
MAZDA 2.0L.....	4-26
YANMAR DIESEL 2.6L.....	4-30
COWL.....	4-34
DIESEL ENGINE	
YANMAR 2.6L.....	4-40
ELECTRONIC CONTROL VALVE	
3 FUNCTION.....	4-42
4 FUNCTION.....	4-44
LIGHTS.....	4-48
LPG ENGINE	
MAZDA 2.0L.....	4-38
TRANSMISSION	
SINGLE SPEED.....	4-46
WORK, REAR DRIVE, AND BRAKE/TAIL LIGHTS.....	4-18

SECTION 1
FRAME

DESCRIPTION	PAGE
CONTROL LEVER LABELS	1-26
COUNTERWEIGHT	1-10
COWL MOUNTING	1-8
ELECTRONIC LEVER LABELS	1-28
FENDER EXTENSIONS AND MUD GUARDS	
WITH WIDE TREAD	1-6
FLOORPLATES AND COVERS	1-4
FORKS	1-32
FULL SUSPENSION SEAT	
WITH AND WITHOUT ELECTRONIC CONTROLS	1-18
FULL SUSPENSION SWIVEL SEAT	
WITH AND WITHOUT ELECTRONIC CONTROLS	1-20
HOOD.....	1-2
JOYSTICK LABELS.....	1-30
LABELS	
EXTERIOR.....	1-22
INTERIOR.....	1-24
LOAD BACKREST EXTENSION.....	1-34
NON SUSPENSION SEAT	
WITHOUT ELECTRONIC CONTROLS	1-14
OVERHEAD GUARD.....	1-12
SEMI SUSPENSION SEAT	
WITH AND WITHOUT ELECTRONIC CONTROLS	1-16

HOOD (Figure 1-1)

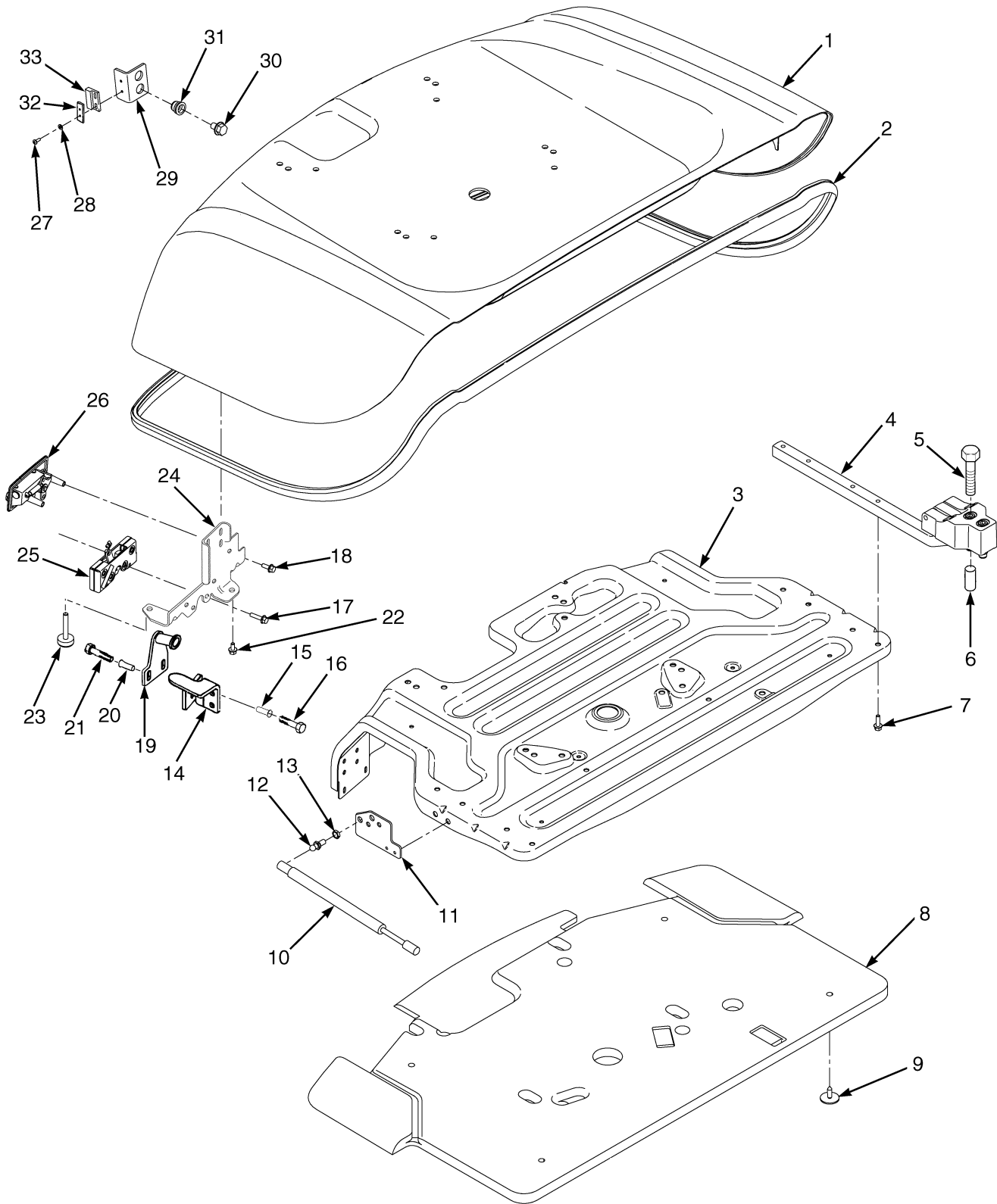

HP120789

HOOD

ITEM	PART NO.	DESCRIPTION	QTY
1	1564008	Hood Assembly (Standard).....	1
1	1567097	Hood Assembly (Used with Overhead Exhaust).....	1
1	1585585	Hood Assembly (Used with Swival Seat).....	1
1	1589729	Hood Assembly (Used with Swival Seat and Overhead Exhaust).....	1
1	1569172	Hood Assembly (Vented).....	1
1	1585586	Hood Assembly (Vented, Used with Swival Seat).....	1
2	1578698	Seal (Hood).....	1
3	1564010	Reinforcement.....	1
4	1547970	Hinge.....	2
5	296030	Capscrew.....	4
6	1530244	Insert.....	4
7	1583611	Capscrew.....	10
8	1548493	Liner.....	1
9	1304971	Fastener.....	4
10	1563497	Gas Spring.....	2
11	1585952	Bracket (Gas Spring Mount).....	2
12	1563369	Ball Stud.....	4
13	329069	Nut.....	2
14	1582018	Plate.....	1
15	1530244	Insert.....	4
16	296032	Capscrew.....	4
17	1527878	Capscrew.....	4
18	1527876	Capscrew.....	2
19	1580794	Striker Bolt.....	1
20	1530243	Insert.....	2
21	1527881	Capscrew.....	2
22	1534417	Capscrew.....	6
23	1585581	Bumper (Hood).....	2
24	1580293	Plate.....	1
25	1582286	Latch Rotor.....	1
26	1582287	Handle.....	1
27	302010	Screw.....	4
28	320152	Washer.....	4
29	1527228	Bracket (Hood Switch).....	2
30	1583611	Capscrew.....	2
31	1531557	Insert.....	2
32	1585765	Plate.....	1
33	1565545	Magnet.....	1
	1347045	Fastener (Not Illustrated).....	8
	1561015	Grommet (Not Illustrated).....	1

FLOORPLATES AND COVERS (Figure 1-2)

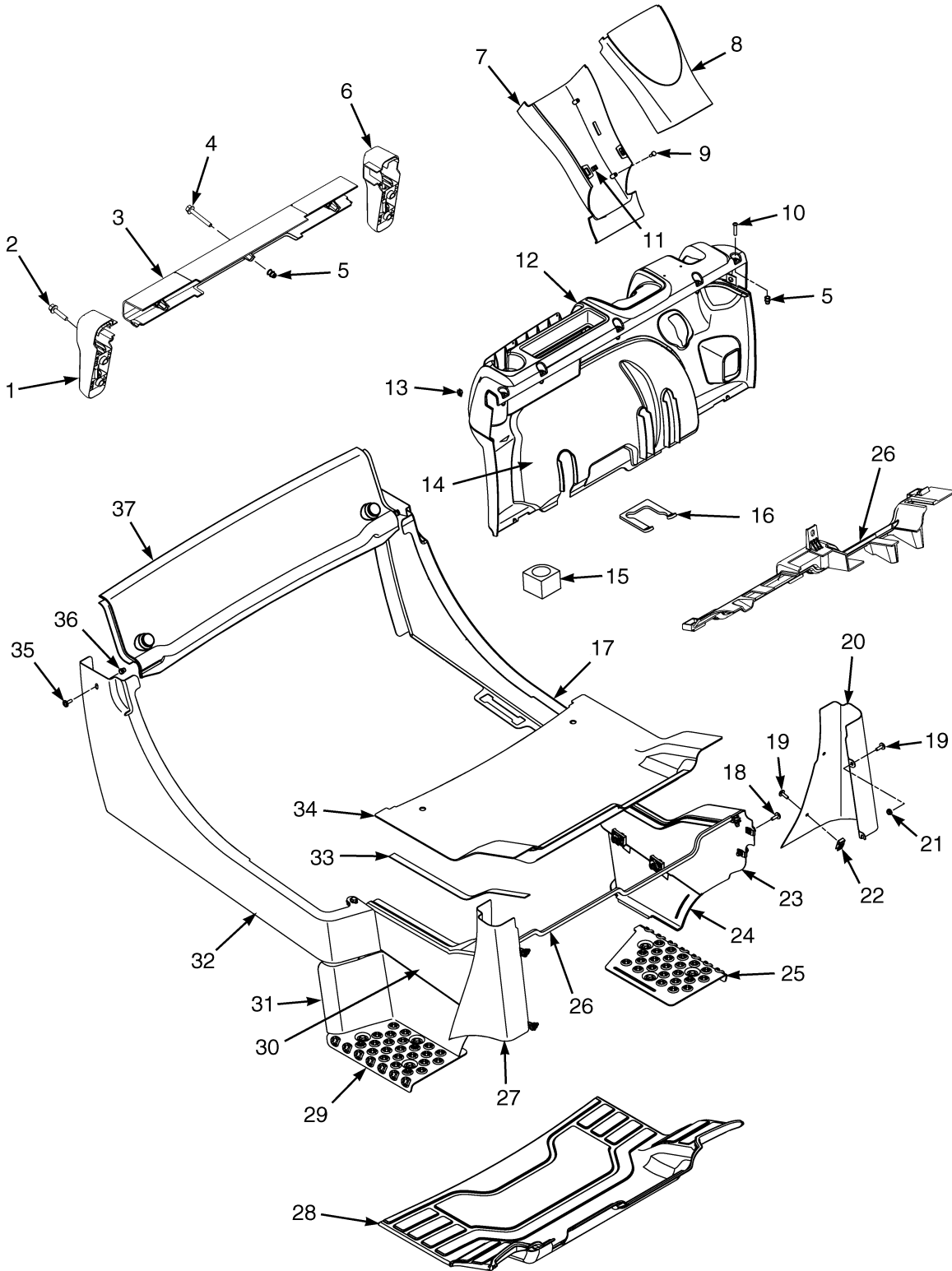

BP120095

FLOORPLATES AND COVERS

ITEM	PART NO.	DESCRIPTION	QTY
1	2056823	Bracket (Tail Light) (RH)	1
2	1586495	Capscrew.....	4
3	2067455	Cover (Rear) (Crossmember).....	1
4	1540643	Capscrew.....	3
5	1531001	Insert.....	8
6	2056822	Bracket (Tail Light) (LH)	1
7	2065666	Cover (Steering Column) (Lower).....	1
8	2065668	Cover (Steering Column) (Upper).....	1
9	2027655	Screw.....	2
10	2071261	Capscrew.....	5
11	2065667	Clip	2
12	1517418	Dash Assembly (Electronic Hydraulics).....	1
12	2065885	Dash	1
12	2070975	Cup Holder	1
12	1517419	Dash Assembly (Manual Valve)	1
12	2065886	Dash	1
12	2070975	Cup Holder	1
13	2065667	Clip	4
14	2071593	Panel (Kick) (Single Pedal).....	1
14	2071594	Panel (Kick) (Dual Pedal).....	1
15	1530135	Grommet (RH) (Foam).....	1
16	1581569	Seal	1
17	a 1527939	Panel (Rear) (LH)	1
17	b 1527940	Panel (Rear) (LH)	1
18	1583611	Capscrew.....	2
19	1530019	Screw.....	8
20	1564026	Cover (Fender) (LH).....	1
21	1514429	Nut (Flange).....	4
22	1350215	Nut (Foldover).....	4
23	1540859	Panel (Front) (LH)	1
24	1574271	Panel (Step) (LH).....	1
25	1519787	Plate (Tread) (LH)	1
26	1564396	Seal Plate Assembly.....	1
26	1529426	Seal	1
27	1564028	Cover (Fender) (RH)	1
28	2072213	Floormat	1
29	1519788	Plate (Tread) (RH).....	1
30	1540869	Panel (Front) (RH)	1
31	1574273	Panel (Step) (RH)	1
32	1527946	Rear Panel (RH)	1
33	1564529	Seal	2
34	1509754	Floor Plate	1
35	1530019	Screw.....	2
36	1531558	Insert.....	6
37	1547460	Cover (Radiator)	1
37	1547467	Seal (LH)	1
37	1547468	Seal (RH).....	1

FOOTNOTES:

- a** Diesel
b LPG

FENDER EXTENSIONS AND MUD GUARDS (Figure 1-3) WITH WIDE TREAD

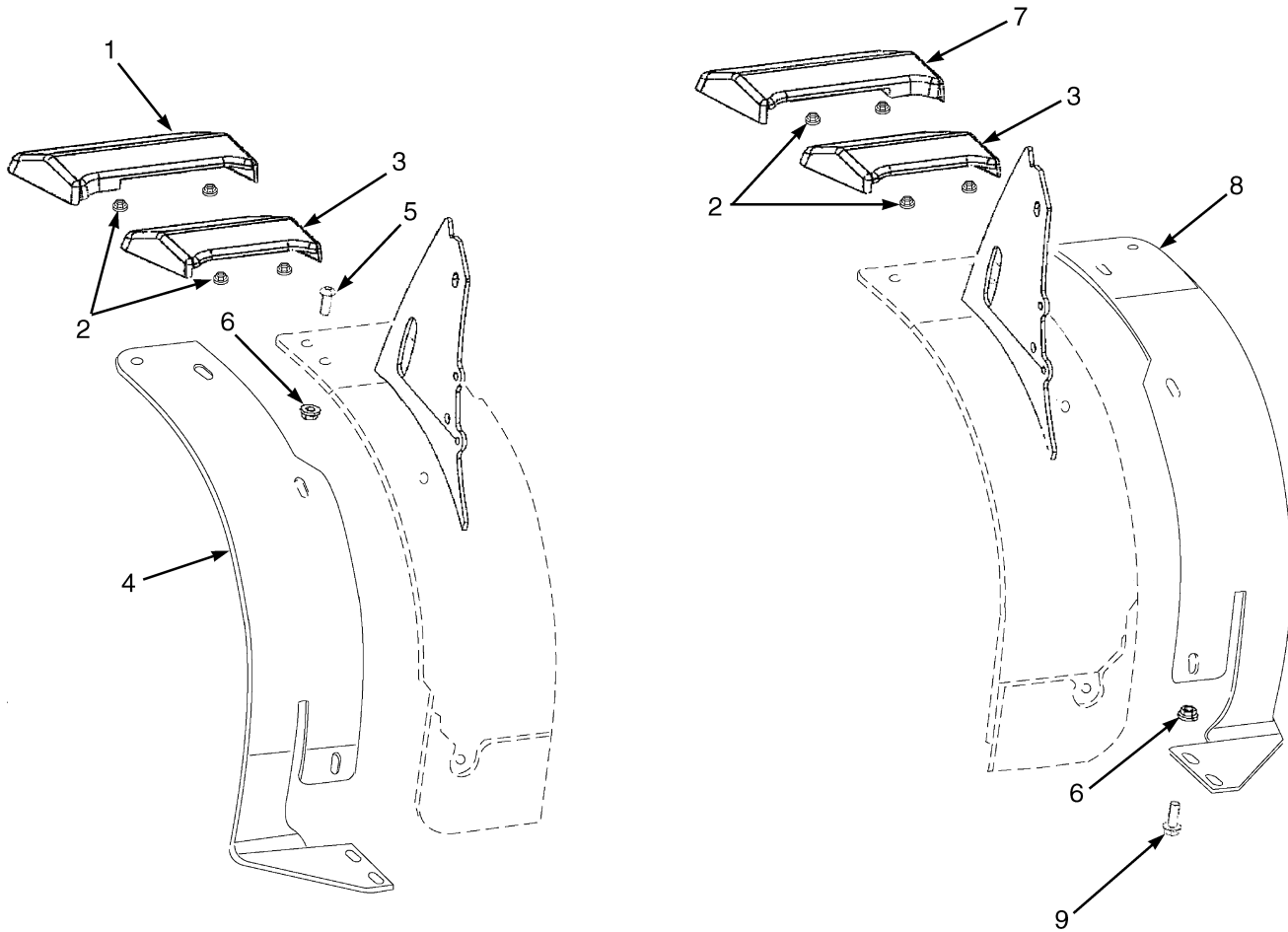

BP120089

FENDER EXTENSIONS AND MUD GUARDS WITH WIDE TREAD

ITEM	PART NO.	DESCRIPTION	QTY
1	2069545	Mud Guard (Wide, RH)	1
2	1544153	Lock Nut.....	4
3	2069008	Mud Guard (Standard).....	2
4	1555786	Fender (Extension, RH).....	1
5	2072664	Capscrew.....	4
6	1586432	Nut	10
7	2069544	Mud Guard (Wide, LH).....	1
8	1555755	Fender (Extension, LH).....	1
9	1586630	Capscrew.....	6

COWL MOUNTING (Figure 1-4)

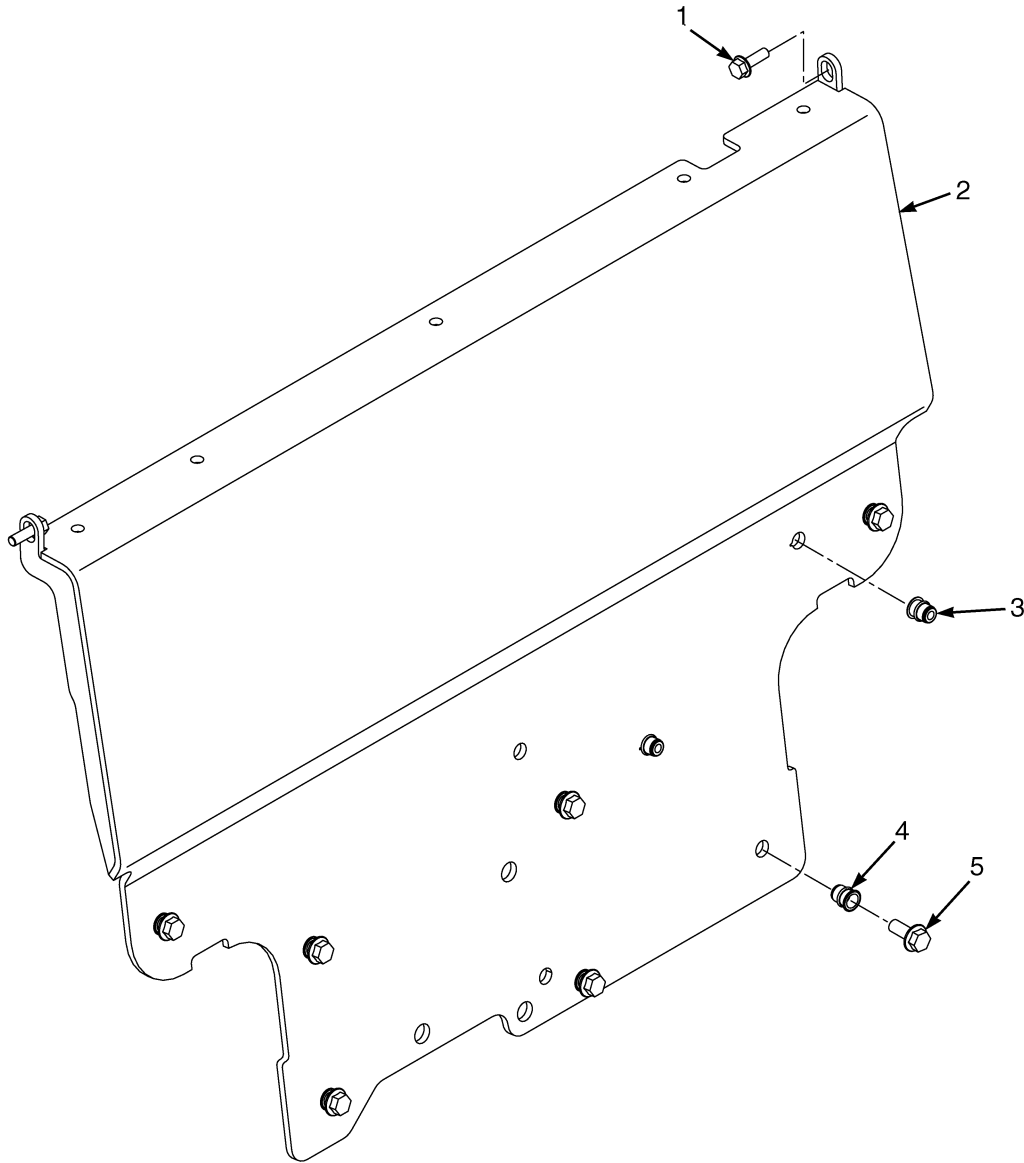

HP120730

ITEM	PART NO.	DESCRIPTION	QTY
1	1583611	Capscrew.....	2
2	1566545	Cowl.....	1
3	1530243	Insert.....	2
4	1530244	Insert.....	7
5	1605990	Capscrew.....	7

COUNTERWEIGHT (Figure 1-5)

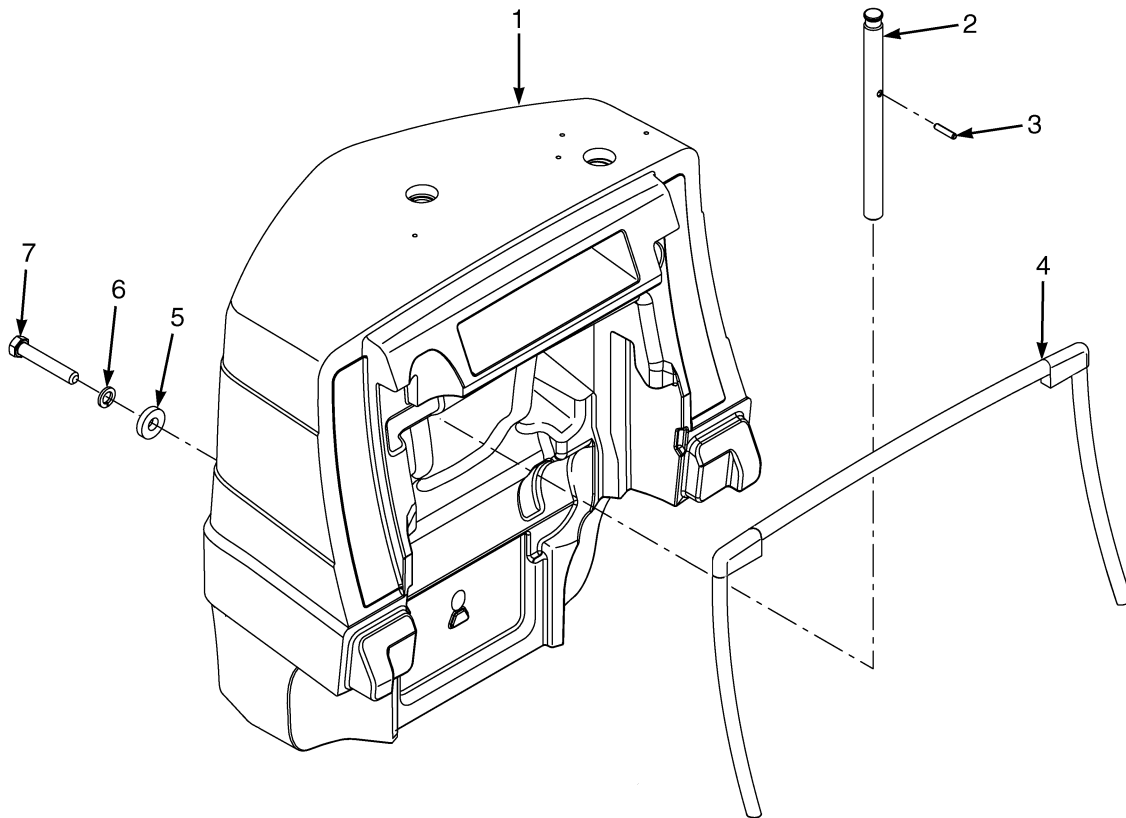

HP120727

COUNTERWEIGHT

ITEM	PART NO.	DESCRIPTION	QTY
1	1528754	Counterweight (H1.6FT)	1
1	1528755	Counterweight (H1.8FT)	1
1	1548756	Counterweight (H2.0FTS).....	1
2	1521190	Tow Pin	1
3	302491	Pin	1
4	1565084	Seal	1
5	1375214	Washer	1
6	292689	Lockwasher.....	1
7	292608	Capscrew (101,6 mm)	1

OVERHEAD GUARD (Figure 1-6)

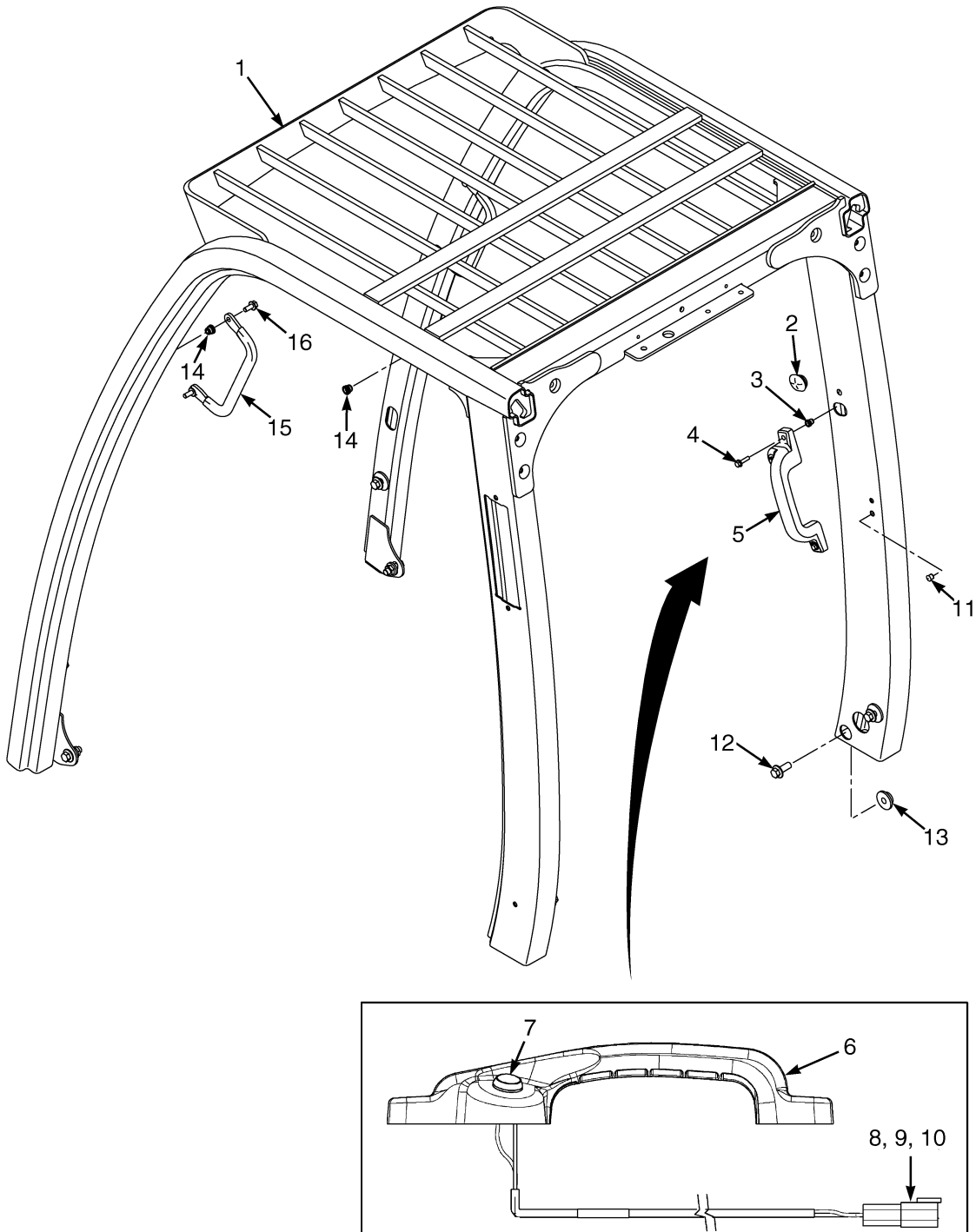

HP120732

OVERHEAD GUARD

ITEM	PART NO.	DESCRIPTION	QTY
1	1599203	Overhead Guard (High)	1
1	1599209	Overhead Guard (Low)	1
2	1558219	Grommet.....	3
3	1531558	Insert.....	2
4	1586495	Capscrew.....	2
5	2070223	Handle Assembly (Optional).....	1
6	2069454	Handle	1
7	1566726	Switch (Horn)	1
8	1493465	Connector.....	1
9	1330414	Secondary Lock.....	1
10	1330437	Terminal (Pin)	2
11	1494888	Plug	2
12	1528889	Capscrew.....	8
13	1528888	Nut	2
14	1531557	Insert.....	4
15	1536813	Handle (Grab).....	1
16	1510113	Capscrew.....	2

NON SUSPENSION SEAT (Figure 1-7) WITHOUT ELECTRONIC CONTROLS

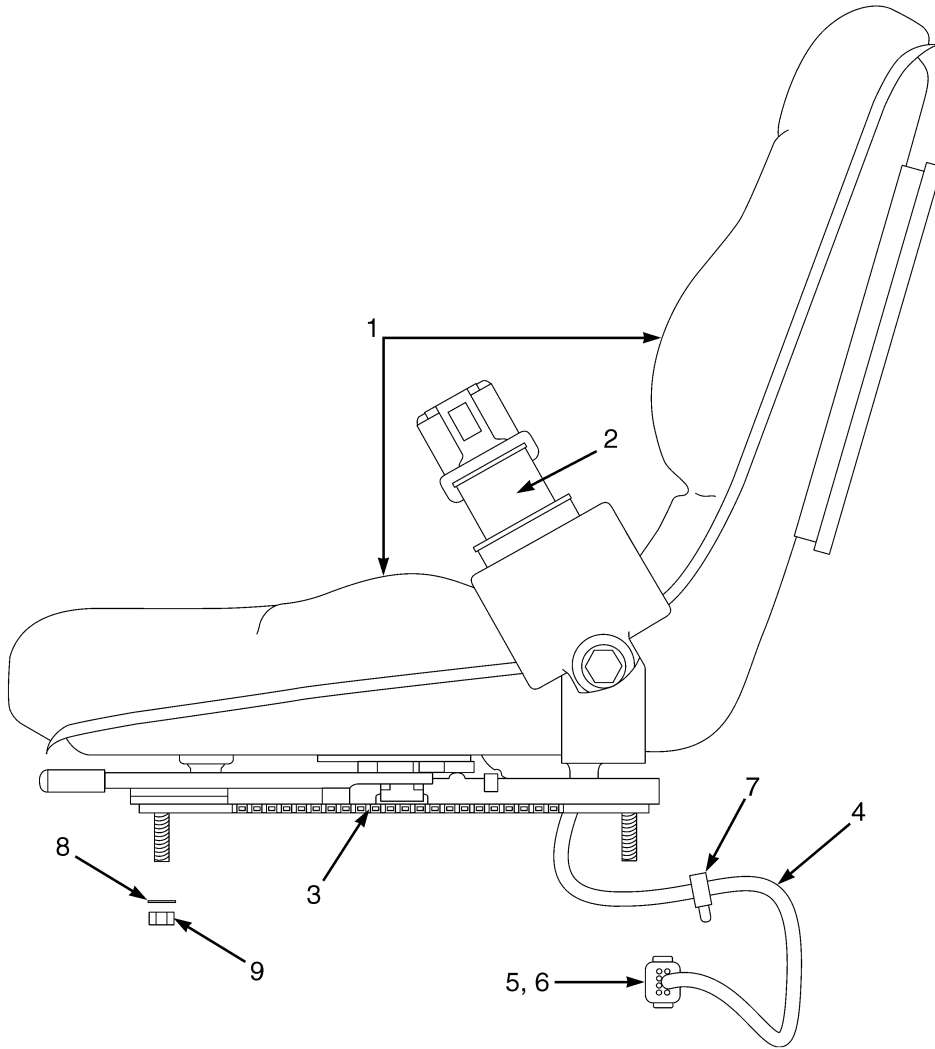

HP120851

NON SUSPENSION SEAT WITHOUT ELECTRONIC CONTROLS

ITEM	PART NO.	DESCRIPTION	QTY
	1593409	Non-Suspension Seat (Vinyl).....	1
1	1563351	Cushions (Vinyl)	1
2	1598504	Seat Belt Kit.....	1
3	1459173	Slide Kit	1
4	1591652	Harness Kit.....	1
4	2075429	Wire Harness	1
4	2070392	Pigtail	1
5	1500912	Clip	1
6	1582464	Fastener	1
7	1500901	Clip	1
8	320158	Washer	4
9	145639	Nut.....	4
	a 1563215	Sensor (Operator Presence)	1

FOOTNOTES:

a Not Illustrated

SEMI SUSPENSION SEAT (Figure 1-8) WITH AND WITHOUT ELECTRONIC CONTROLS

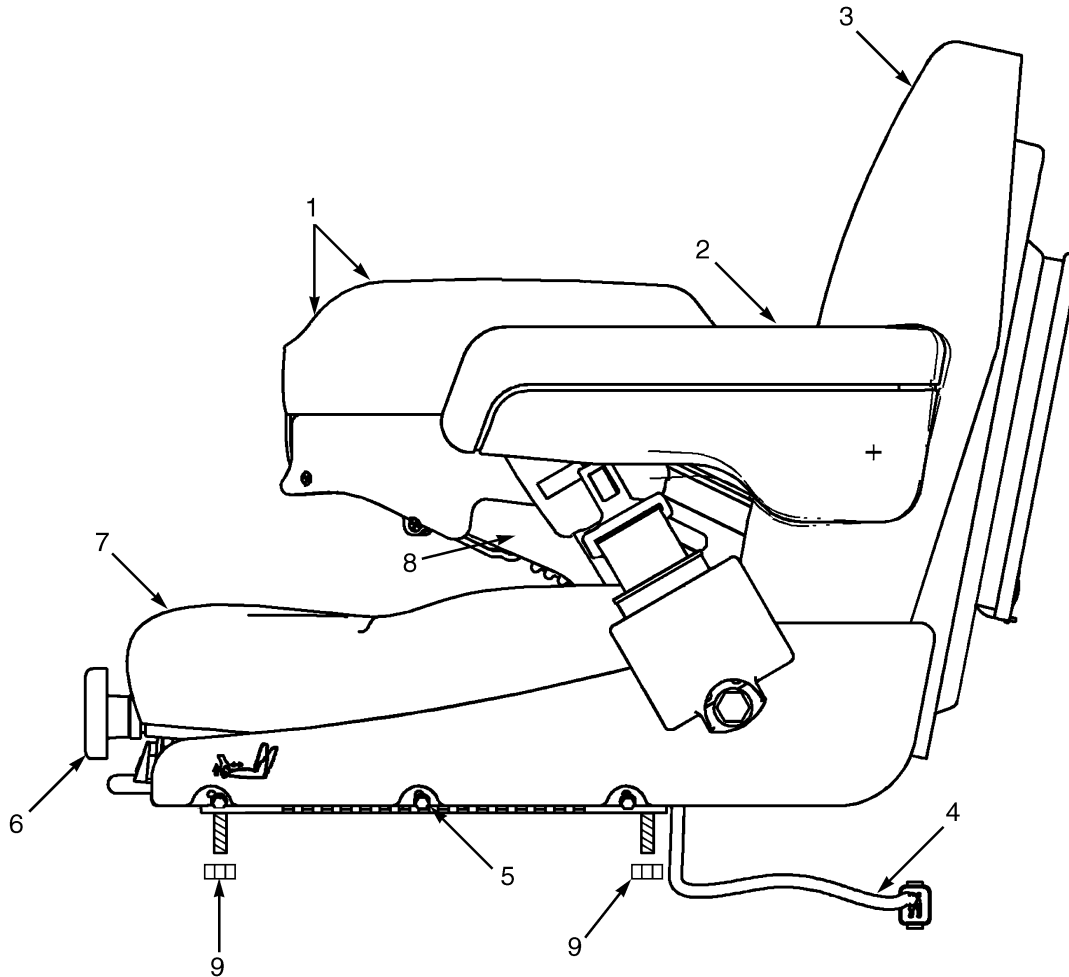

BP120109

SEMI SUSPENSION SEAT WITH AND WITHOUT ELECTRONIC CONTROLS

KEY:**A: Without Arm Controls****B: With Arm Controls**

ITEM	PART NO.	DESCRIPTION	QTY	
			A	B
	1593411	Seat Assembly (Vinyl).....	1	..
	1593412	Seat Assembly (Cloth).....	1	..
	1593415	Seat Assembly (Vinyl).....	..	1
	1593416	Seat Assembly (Cloth).....	..	1
1	1453882	Armrest.....	1	..
1	1453883	Armrest.....	1	..
2	1563210	Foam Cap (Electronic Control Arm)	1
2	1563211	Knobs (Electronic Control Arm).....	..	1
3	1382111	Back Cushion (Vinyl).....	1	1
3	1382113	Back Cushion (Cloth)	1	1
4	2075429	Wire Harness	1	..
4	2075428	Wire Harness	1
5	1459173	Slide Kit	1	..
5	1563895	Slide Kit	1
6	1563227	Weight Adjust Knob.....	1	1
7	1382112	Seat Cushion (Vinyl).....	1	1
7	1382114	Seat Cushion (Cloth).....	1	1
8	1598504	Seat Belt Kit.....	1	1
9	191941	Nut	4	4
	a 1362049	Shock Absorber Kit.....	1	1
	a 1563215	Sensor (Operator Presence).....	1	1

FOOTNOTES:**a** Not Illustrated

FULL SUSPENSION SEAT (Figure 1-9) WITH AND WITHOUT ELECTRONIC CONTROLS

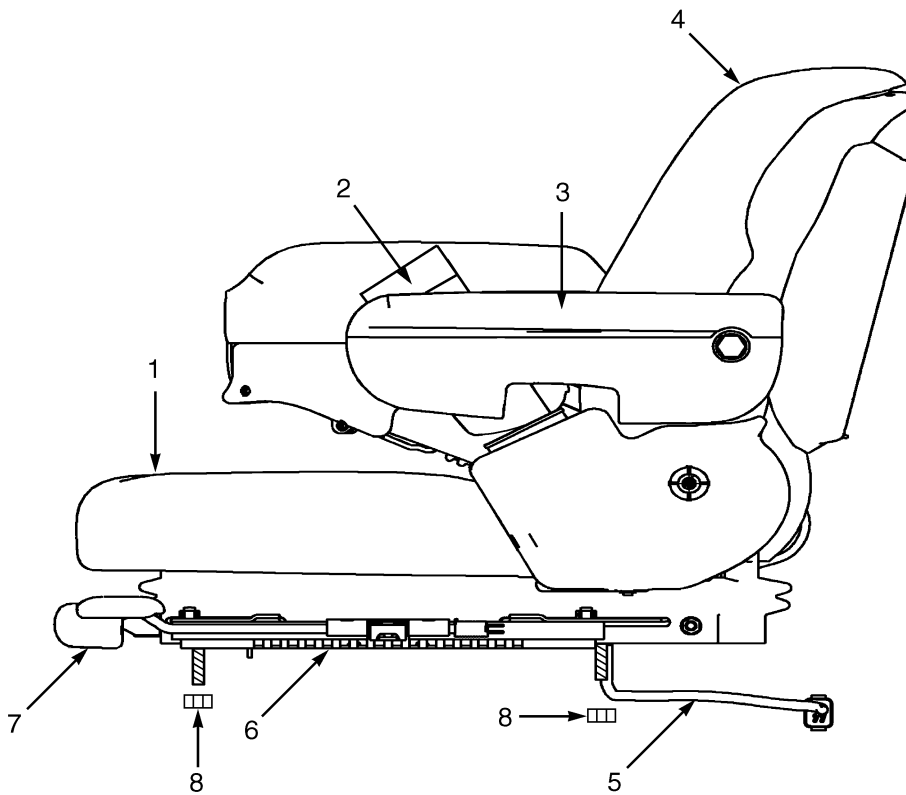

BP120111

FULL SUSPENSION SEAT WITH AND WITHOUT ELECTRONIC CONTROLS

KEY:

- A: Full Suspension (Vinyl)**
B: Full Suspension (Cloth)
C: Full Suspension (Vinyl with Electronic Control Arm)
D: Full Suspension (Cloth with Electronic Control Arm)

ITEM	PART NO.	DESCRIPTION	QTY			
			A	B	C	D
	1593413	Full Suspension Seat (Vinyl).....	1
	1593414	Full Suspension Seat (Cloth).....	..	1
	1593417	Full Suspension Seat (Vinyl).....	1	..
	1593418	Full Suspension Seat (Cloth).....	1
1	1563207	Seat Cushion.....	1	..	1	..
1	1566453	Seat Cushion.....	..	1	..	1
2	1598504	Seat Belt Kit.....	1	1	1	1
3	1563230	Arm Cushion (LH)	1	1	1	1
3	1563231	Arm Cushion (RH).....	1	1
4	1470152	Back Cushion (Vinyl)	1	..	1	..
4	1470153	Back Cushion (Cloth)	1	..	1
5	2075429	Wire Harness.....	1	1
5	2075428	Wire Harness	1	1
6	1470161	Slide Kit.....	1	1	1	1
7	1470163	Weight Adjuster Kit.....	1	1	1	1
8	191941	Nut.....	4	4	4	4
	a 1483828	Shock Kit.....	1	1	1	1
	a 1563210	Foam Cap (Electronic Control Arm).....	1	1
	a 1563211	Knobs (Electronic Control Arm)	1	1
	a 1563208	Sensor	1	1	1	1

FOOTNOTES:

- a** Not Illustrated

FULL SUSPENSION SWIVEL SEAT (Figure 1-10) WITH AND WITHOUT ELECTRONIC CONTROLS

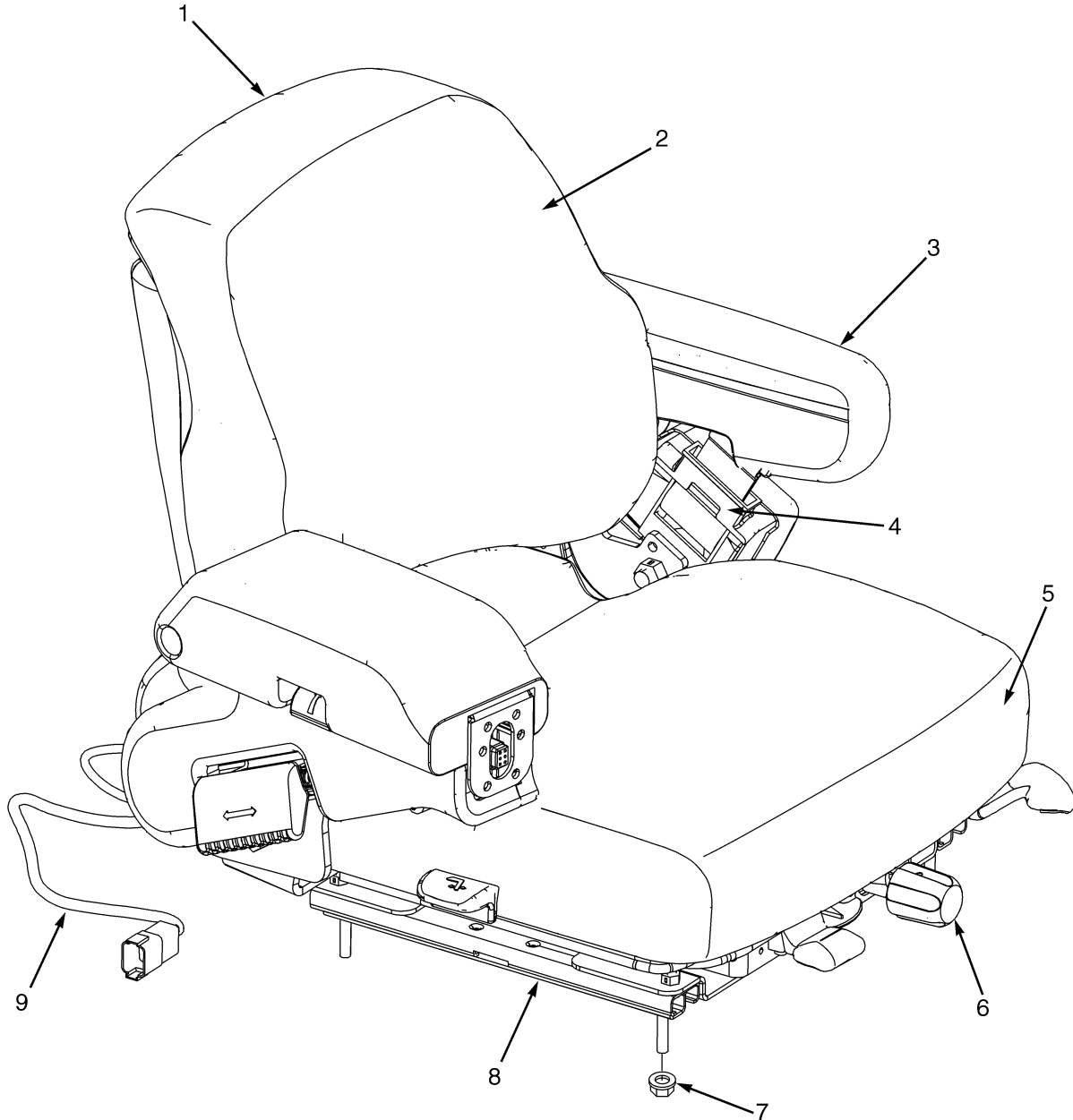

BP120119

FULL SUSPENSION SWIVEL SEAT WITH AND WITHOUT ELECTRONIC CONTROLS

ITEM	PART NO.	DESCRIPTION	QTY
1	1593421	Seat Assembly (Vinyl) (With Armrests).....	1
1	1593422	Seat Assembly (Cloth) (With Armrests).....	1
1	1593423	Seat Assembly (Vinyl) (With Electronic Controls).....	1
1	1593424	Seat Assembly (Cloth) (With Electronic Controls).....	1
2	1470152	Back Cushion (Vinyl).....	1
2	1470153	Back Cushion (Cloth).....	1
3	1563230	Arm Cushion (LH).....	1
4	1598504	Seat Belt Kit.....	1
5	1563207	Seat Cushion (Vinyl).....	1
5	1566453	Seat Cushion (Cloth).....	1
6	1470163	Weight Adjuster Kit.....	1
7	191941	Nut.....	4
8	1470161	Slide Kit.....	1
9	2075429	Wire Harness (Without Electronic Controls).....	1
9	2075428	Wire Harness (With Electronic Controls).....	1
	a 1563211	Knobs (Electronic Control Arm).....	1
	a 1563210	Foam Cap (Electronic Control Arm).....	1
	a 1563231	Arm Cushion (RH) (Without Electronic Controls).....	1
	a 1483828	Shock Kit.....	1
	a 1563208	Sensor.....	1

FOOTNOTES:

a Not Illustrated

Thank you so much for reading.
Please click the “Buy Now!”
button below to download the
complete manual.



After you pay.

You can download the most
perfect and complete manual in
the world immediately.

Our support email:

ebooklibonline@outlook.com