

PARTS MANUAL

CHALLENGER

**H8.00-12.00XM
(F007)**

CUSTOMER EDITION

HYSTER

SECTIONS

1	FRAME
2	ENGINES
3	FUEL SYSTEM
4	ELECTRICAL SYSTEM
5	TRANSMISSION
6	DRIVE AXLE
7	STEERING SYSTEM
8	BRAKE SYSTEM
9	HYDRAULIC SYSTEM
10	MAST-TWO STAGE LIMITED FREE-LIFT
11	MAST-THREE STAGE FULL FREE-LIFT
12	OPTIONS
13	NUMERICAL INDEX

TABLE OF CONTENTS

DESCRIPTION	PAGE
A	
ACCUMULATOR	
PISTON TYPE	9-8
AIR COMPRESSOR	
SHEET 1 OF 2	2-54
SHEET 2 OF 2	2-56
AIR COMPRESSOR AND ATTACHING PARTS	2-52
AIR CONDITIONING SYSTEM	1-50
AIR DRYER	
⇒S/N PENDING PER ECN 68250	2-16
AIR DRYER AND ATTACHING PARTS	
S/N PENDING PER ECN 68250⇒	2-18
AIR DUCT	
ENGINE	
TIER I ENGINE	2-44
AIR DUCT AND ACCESSORIES	
CAB.....	1-76
AIR FILTER	
WITHOUT ASPIRATED PRE-CLEANER	
TIER I ENGINE	3-14
TIER II ENGINE	3-30
ALTERNATOR	4-18
ALTERNATOR AND PULLEY	
PERKINS	
TIER II ENGINE	4-20
ALTERNATOR BRACKET AND ATTACHING PARTS	
PERKINS	
TIER II ENGINE	4-22
ARMREST	
PIVOT-UP	1-84
AUXILIARY DRIVE GEAR	
TIER II ENGINE	2-92
AUXILIARY DRIVE GEAR AND AIR COMPRESSOR	
TIER I ENGINE	2-34
AXLE HOUSING AND ATTACHING PARTS	6-22
B	
BLANKING PLATE AND PLUGS	
TIER II ENGINE	2-96
BLANKING PLUG, OIL FEED AND HOSES	
TIER II ENGINE	2-94
BRAKE ACCUMULATOR	8-10
BRAKE ASSEMBLY	
DRY BRAKE	8-14
WET BRAKE	8-12
BRAKE CHAMBER	8-16
BRAKE SYSTEM	
DRY	8-6
WET	8-2
BRAKE VALVE	
DRY BRAKE	8-20
WET BRAKE	8-18

TABLE OF CONTENTS (Continued)

DESCRIPTION	PAGE
C	
CAB AND ATTACHING PARTS	1-18
CAB AND TILT CYLINDER MOUNTING.....	1-38
CAB HARDWARE AND CONTROL COVER.....	1-74
CAB MOUNTED DRIVE LIGHTS.....	12-62
CAMSHAFT AND ROCKER ASSEMBLY	
TIER II ENGINE.....	2-74
CARRIAGE	
FOUR, FIVE, AND SIX FUNCTION.....	11-16
INDIVIDUAL FORK POSITIONER	
FOUR FUNCTION.....	11-18
S/N F007E-02356A⇒ INC. 2348.....	10-24
⇒S/N F007E-02355A.....	10-20
SIMULTANEOUS FORK POSITIONER	
THREE FUNCTION.....	10-28
SIMULTANEOUS FORK POSITIONER (THREE FUNCTION)	
THREE STAGE FULL FREE-LIFT	11-20
STANDARD PIN TYPE	
THREE FUNCTION WITHOUT HOSE GROUP	10-14
WITH HOSE GROUP	
S/N F007E-02356A⇒ INC. 2348.....	10-16
THREE FUNCTION	11-14
CHARGE PUMP.....	5-22
CLUTCH	
FORWARD AND LOW.....	5-14
REVERSE AND SECOND.....	5-16
THIRD.....	5-18
CONDENSER.....	1-60
CONTROL LEVER	
ELECTRONIC	
S/N F007E-02350A⇒.....	9-36
⇒S/N F007E-02349A.....	9-34
CONTROL PANEL	
AIR CONDITIONER	
D/B 11/2003⇒.....	4-12
HEATER	
D/B 11/2003⇒.....	4-10
CONTROL VALVE	
⇒S/N F007E-01814Z	9-22
S/N F007E-01815Z⇒.....	9-24
TRANSMISSION.....	5-26
COOLING	
TIER I ENGINE.....	2-8
TIER II ENGINE.....	2-60
COUNTERWEIGHT	1-10
CRANKSHAFT AND MAIN BEARINGS	
TIER II ENGINE.....	2-70
CRANKSHAFT AND PISTON	
TIER I ENGINE.....	2-24
CYLINDER BLOCK	
TIER I ENGINE.....	2-22
TIER II ENGINE.....	2-64

TABLE OF CONTENTS (Continued)

DESCRIPTION	PAGE
C (continued)	
CYLINDER HEAD	
TIER I ENGINE.....	2-26
TIER II ENGINE.....	2-66
CYLINDER HEAD COVER	
TIER II ENGINE.....	2-68
D	
DASH DISPLAY	
CAB.....	1-78
DC-DC CONVERTER AND ATTACHING PARTS.....	4-14
DIFFERENTIAL AND CARRIER	
475 SERIES WET BRAKE.....	6-10
WET BRAKE	
S/N F007E02553A⇒.....	6-6
DIFFERENTIAL/CARRIER	
DRY BRAKE	
⇒S/N F007E02666A.....	6-14
S/N F007E02667A⇒.....	6-18
WET BRAKE	
⇒S/N F007E02552A.....	6-2
DIRECTIONAL CONTROL VALVE	
S/N F007E02356A⇒.....	12-52
DOOR	
GLASS	
⇒S/N F007E-02789B.....	1-26
STEEL	
⇒S/N F007E-02789B.....	1-30
E	
ELECTRICAL PUMP	
CAB TILT.....	1-46
ELECTRICAL SYSTEM	
TIER I ENGINE.....	4-2
TIER II ENGINE.....	4-6
ELECTRONIC CONTROL MODULE AND MOUNTING	
TIER II ENGINE.....	2-114
ENGINE ASSEMBLY.....	2-4
ENGINE BLOCK HEATER.....	2-14
ENGINE LIFTING EYES	
TIER II ENGINE.....	2-112
ENGINE MOUNT.....	2-12
EXHAUST	
TIER I ENGINE.....	2-6
TIER II ENGINE.....	2-58
F	
FAN DRIVE AND PULLEY	
TIER II ENGINE.....	2-90
FLOOR PLATES AND COVERS	

TABLE OF CONTENTS (Continued)

DESCRIPTION	PAGE
F (continued)	
⇒S/N F007E-02438A	1-12
S/N F007E-02439A⇒	1-16
FLYWHEEL.....	2-20
FORK POSITIONING CYLINDER.....	12-48
FORKS	
IDENTIFY BY PART NUMBER	12-46
FREE-LIFT CYLINDER	
THREE STAGE FULL FREE-LIFT	11-10
FRONT DRIVE PULLEY	
TIER II ENGINE	2-88
FRONT, BRAKE AND BACK-UP LIGHTS	12-58
FUEL FILTER	
TIER I ENGINE	3-12
FUEL FILTER ASSEMBLY	
TIER II ENGINE	3-28
FUEL INJECTION	
TIER I ENGINE	3-4
FUEL INJECTION PUMP AND GEAR	
TIER II ENGINE	3-18
FUEL INJECTION SUPPLY AND RETURN LINES	
TIER II ENGINE	3-22
FUEL SYSTEM	
TIER I ENGINE	3-2
TIER II ENGINE	3-16
G	
GENERAL TRUCK	1-4
H	
HAND PUMP	
CAB TILT.....	1-44
HEADER HOSE	
THREE STAGE FULL FREE-LIFT	11-12
TWO STAGE LIMITED FREE-LIFT	
⇒S/N F007E-02355A.....	10-32
S/N F007E-02356A⇒ INC. 2348	10-36
HEATER AND AIR CONDITIONER	
⇒D/B 11/2003	1-52
HEATER AND AIR CONDITIONER ASSEMBLY	
D/B 11/2003⇒	1-58
HEATER AND AIR CONDITIONER ATTACHMENT	
D/B 11/2003⇒	1-54
HEATER ASSEMBLY	
D/B 11/2003⇒	1-56
HEATER ATTACHING PARTS	1-48
HIGH PRESSURE FUEL PIPES	
TIER II ENGINE	3-20
HOOD.....	1-6
HUB AND SHAFT ASSEMBLY	

TABLE OF CONTENTS (Continued)

DESCRIPTION	PAGE
H (continued)	
475 SERIES WET BRAKE.....	6-26
DRY BRAKE	
⇒S/N F007E02666A.....	6-28
S/N F007E02667A⇒.....	6-30
WET BRAKE.....	6-24
HYDRAULIC PUMP	
NON-TURBO.....	9-14
TURBO.....	9-16
HYDRAULIC SUPPLY AND RETURN.....	9-2
HYDRAULIC TANK AND ATTACHING PARTS	
⇒S/N F007E-02438A.....	9-10
S/N F007E-02439A⇒.....	9-12
HYDRAULIC VALVE AND ATTACHING PARTS.....	9-18
I	
IDLER GEAR	
TIER II ENGINE.....	2-86
IDLER SHAFT.....	5-20
INCHING PEDAL AND ACCESSORIES	
CAB.....	1-22
INCHING PEDAL LINKAGE.....	5-6
INDICATOR DISPLAY ASSEMBLY.....	1-80
INNER MAST	
TWO STAGE LIMITED FREE-LIFT.....	10-4
J	
JOYSTICK CONTROL.....	9-32
L	
LABELS.....	1-72
LIFT	
TWO STAGE LIMITED FREE-LIFT.....	10-6
LIFT ACCUMULATOR AND ATTACHING PARTS.....	9-6
LIFT PUMP	
TIER I ENGINE.....	3-10
LIFT PUMP AND FUEL FILTER LINES	
TIER II ENGINE.....	3-24
LIFT PUMP ASSEMBLY	
TIER II ENGINE.....	3-26
LIFTING EYES.....	12-66
LOW PRESSURE SYSTEM	
TIER I ENGINE.....	3-8
LUBRICANT SYSTEM	
TIER I ENGINE.....	2-46

TABLE OF CONTENTS (Continued)

DESCRIPTION	PAGE
M	
MAIN LIFT CYLINDER	
THREE STAGE FULL FREE-LIFT	11-9
TWO STAGE LIMITED FREE-LIFT	10-10
MANIFOLDS	
NON-TURBO	
TIER I ENGINE	2-50
TIER II ENGINE	2-84
TURBO	
TIER I ENGINE	2-48
MAST AND REAR WORK LIGHTS	12-54
MAST ASSEMBLY	
THREE STAGE FULL FREE-LIFT	
SHEET 1 OF 3	11-2
SHEET 2 OF 3	11-4
SHEET 3 OF 3	11-6
MAST INSTALLATION	9-40
MODULATOR VALVE	5-24
MONOTROL PEDAL	3-40
O	
OIL COOLER	
WET BRAKE	8-9
OIL COOLER AND CONNECTIONS	
TIER II ENGINE	2-102
OIL FILTER	
NON-TURBO	
TIER I ENGINE	2-38
OIL FILTER AND ATTACHING PARTS	
TIER II ENGINE	2-100
OIL FILTER AND COOLER	
TURBO	
TIER I ENGINE	2-36
OIL PUMP AND DELIVERY HOUSING	
TIER II ENGINE	2-98
OIL SUMP	
TIER I ENGINE	2-32
TIER II ENGINE	2-82
OUTER MAST	
TWO STAGE LIMITED FREE-LIFT	10-2
OUTPUT GEAR	5-21
P	
PARK BRAKE	
WET BRAKE	8-22
PICK-UP SENSORS	
TIER II ENGINE	2-118
PILOT VALVE	9-28
PISTON AND CONNECTING ROD	
TIER II ENGINE	2-72
PUMP DRIVE GEARS	5-12

TABLE OF CONTENTS (Continued)

DESCRIPTION	PAGE
R	
REVERSE ALARM	12-68
ROTATING BEACON	12-64
S	
SEAT ASSEMBLY	
AIR	1-62
MECHANICAL	1-64
SELECTOR VALVE	12-50
SIDE-SHIFT CARRIAGE	
THREE STAGE FULL FREE-LIFT	
FOUR, FIVE, AND SIX FUNCTION	12-32
INDIVIDUAL FORK POSITIONER (FIVE FUNCTION)	12-36
SIMULTANEOUS FORK POSITIONER (FOUR FUNCTION)	12-40
THREE FUNCTION	12-30
TWO STAGE LIMITED FREE-LIFT	
FOUR AND FIVE FUNCTION	12-6
INDIVIDUAL FORK POSITIONER	
⇒S/N F007E02355A	12-14
INDIVIDUAL FORK POSITIONER (FIVE FUNCTION)	
S/N F007E02356A⇒	12-18
SIMULTANEOUS FORK POSITIONER	
⇒S/N F007E02355A	12-22
SIMULTANEOUS FORK POSITIONER (FOUR FUNCTION)	
S/N PENDING PER ECN 68183⇒	12-26
THREE FUNCTION	12-4
WITH HOSE GROUP	
S/N F007E02356A⇒	12-10
SIDE-SHIFT CYLINDER	12-44
STARTER MOTOR	
TIER I ENGINE	4-16
STEEL DOOR	
LEFT HAND	
S/N F007E-02790B⇒	1-36
RIGHT HAND	
S/N F007E-02790B⇒	1-34
STEERING AXLE	7-12
STEERING COLUMN AND ATTACHING PARTS	7-4
STEERING COLUMN ASSEMBLY	7-8
STEERING CYLINDER	7-16
STEERING PUMP	
⇒D/B 09/2003	7-10
STEERING SYSTEM	7-2
T	
THERMOSTAT AND WATER OUTLET HOUSING	
TIER II ENGINE	2-104
THROTTLE LINKAGE	3-34
THROTTLE PEDAL LINKAGE	
FORWARD AND REVERSE	3-36
MONOTROL PEDAL	3-38
TILT CYLINDER	9-30

TABLE OF CONTENTS (Continued)

DESCRIPTION	PAGE
T (continued)	
CAB.....	1-42
TILT CYLINDER AND ATTACHING PARTS	
MAST.....	9-26
TIMING CASE AND ALTERNATOR MOUNTING	
TIER II ENGINE.....	2-76
TIMING COVER	
TIER II ENGINE.....	2-78
TIMING GEAR	
TIER I ENGINE.....	2-30
TIER II ENGINE.....	2-80
TIRE AND WHEEL.....	12-2
TORQUE CONVERTER.....	5-2
TRAINING SEAT.....	1-70
TRANSMISSION.....	5-8
TRANSMISSION MOUNT AND ATTACHING PARTS.....	5-4
TURBO DRAIN PIPE AND BLANKING PLATE	
TIER II ENGINE.....	2-110
TURBOCHARGER	
TIER I ENGINE.....	2-42
TURBOCHARGER AND ATTACHING PARTS	
TIER II ENGINE.....	2-108
V	
VALVE COVER	
TIER I ENGINE.....	2-28
W	
WATER PUMP	
TIER I ENGINE.....	2-40
TIER II ENGINE.....	2-106
WATER SEPERATOR.....	3-32
WINDOW WASHER AND ARMREST ASSEMBLY.....	1-82
WIRE HARNESS	
ARMREST	
WITH CLOSED CAB.....	4-34
WITH OPEN CAB.....	4-36
AUTOSHIFT BY-PASS.....	4-38
CAB SIDE CONSOLE	
⇒S/N F007E-01803Z.....	4-42
S/N F007E-01804Z⇒.....	4-46
CAB UNDERFLOOR.....	4-40
CLOSED CAB.....	4-32
FUSES AND RELAY.....	4-24
MAST TWO STAGE LIMITED FREE-LIFT	
⇒S/N F007E-02355A EXC. 2348.....	4-51
S/N F007E-02356A⇒ INC. 2348.....	4-52
OPEN CAB.....	4-30
REAR WIPER.....	4-28
STEERING COLUMN.....	4-26

TABLE OF CONTENTS (Continued)

DESCRIPTION	PAGE
W (continued)	
WIRING LOOMS TIER II ENGINE	2-116

**SECTION 1
FRAME**

DESCRIPTION	PAGE
AIR CONDITIONING SYSTEM	1-50
AIR DUCT AND ACCESSORIES	
CAB.....	1-76
ARMREST	
PIVOT-UP	1-84
CAB AND ATTACHING PARTS	1-18
CAB AND TILT CYLINDER MOUNTING.....	1-38
CAB HARDWARE AND CONTROL COVER.....	1-74
CONDENSER.....	1-60
COUNTERWEIGHT	1-10
DASH DISPLAY	
CAB.....	1-78
DOOR	
GLASS	
⇒S/N F007E-02789B.....	1-26
STEEL	
⇒S/N F007E-02789B.....	1-30
ELECTRICAL PUMP	
CAB TILT.....	1-46
FLOOR PLATES AND COVERS	
⇒S/N F007E-02438A	1-12
S/N F007E-02439A⇒	1-16
GENERAL TRUCK	1-4
HAND PUMP	
CAB TILT.....	1-44
HEATER AND AIR CONDITIONER	
⇒D/B 11/2003	1-52
HEATER AND AIR CONDITIONER ASSEMBLY	
D/B 11/2003⇒	1-58
HEATER AND AIR CONDITIONER ATTACHMENT	
D/B 11/2003⇒	1-54
HEATER ASSEMBLY	
D/B 11/2003⇒	1-56
HEATER ATTACHING PARTS	1-48
HOOD.....	1-6
INCHING PEDAL AND ACCESSORIES	
CAB.....	1-22
INDICATOR DISPLAY ASSEMBLY.....	1-80
LABELS.....	1-72
SEAT ASSEMBLY	
AIR.....	1-62
MECHANICAL	1-64
STEEL DOOR	
LEFT HAND	
S/N F007E-02790B⇒.....	1-36
RIGHT HAND	
S/N F007E-02790B⇒.....	1-34
TILT CYLINDER	
CAB.....	1-42
TRAINING SEAT	1-70

SECTION 1 FRAME (Continued)

DESCRIPTION	PAGE
WINDOW WASHER AND ARMREST ASSEMBLY	1-82

GENERAL TRUCK (Figure 1-1)

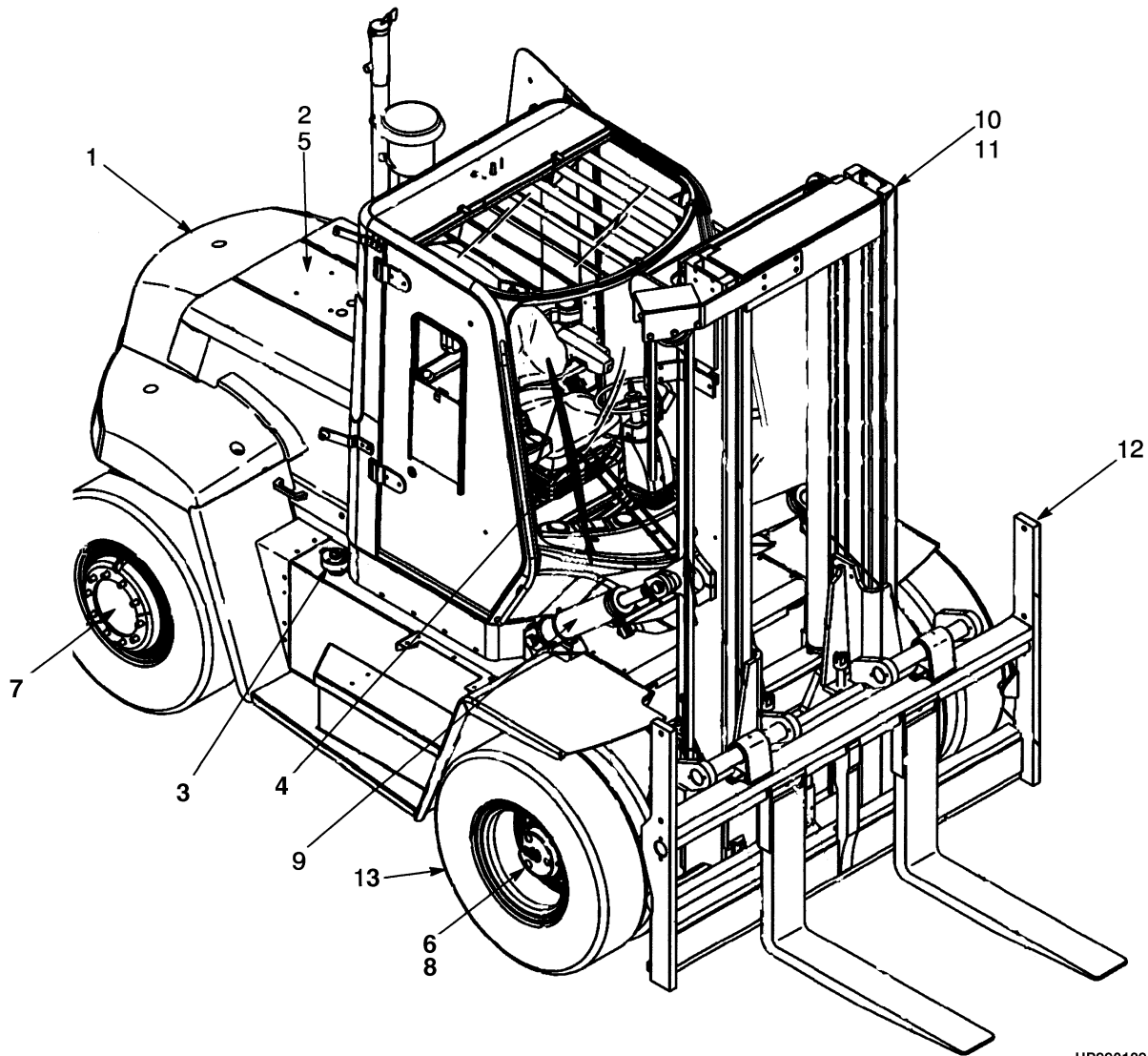

HP990129

GENERAL TRUCK

ITEM	PART NO.	DESCRIPTION	QTY
1	Frame (☞ Figure 1-4)	1
2	Engine Assembly (☞ Figure 2-9)	1
3	Fuel System (☞ Figure 3-1)	1
4	Electrical System (☞ Figure 4-1)	1
5	Transmission (☞ Figure 5-4)	1
6	Drive Axle (☞ Figure 6-1)	1
7	Steering System (☞ Figure 7-5)	1
8	Brake System (☞ Figure 7-1)	1
9	Hydraulic System (☞ Figure 9-1)	1
10	Mast-Two Stage Limited Free-Lift (☞ Figure 9-1)	1
11	Mast-Three Stage Full Free-Lift (☞ Figure 11-1)	1
12	Options (☞ Figure 12-3)	1
13	Numerical Index.....	1

HOOD (Figure 1-2)

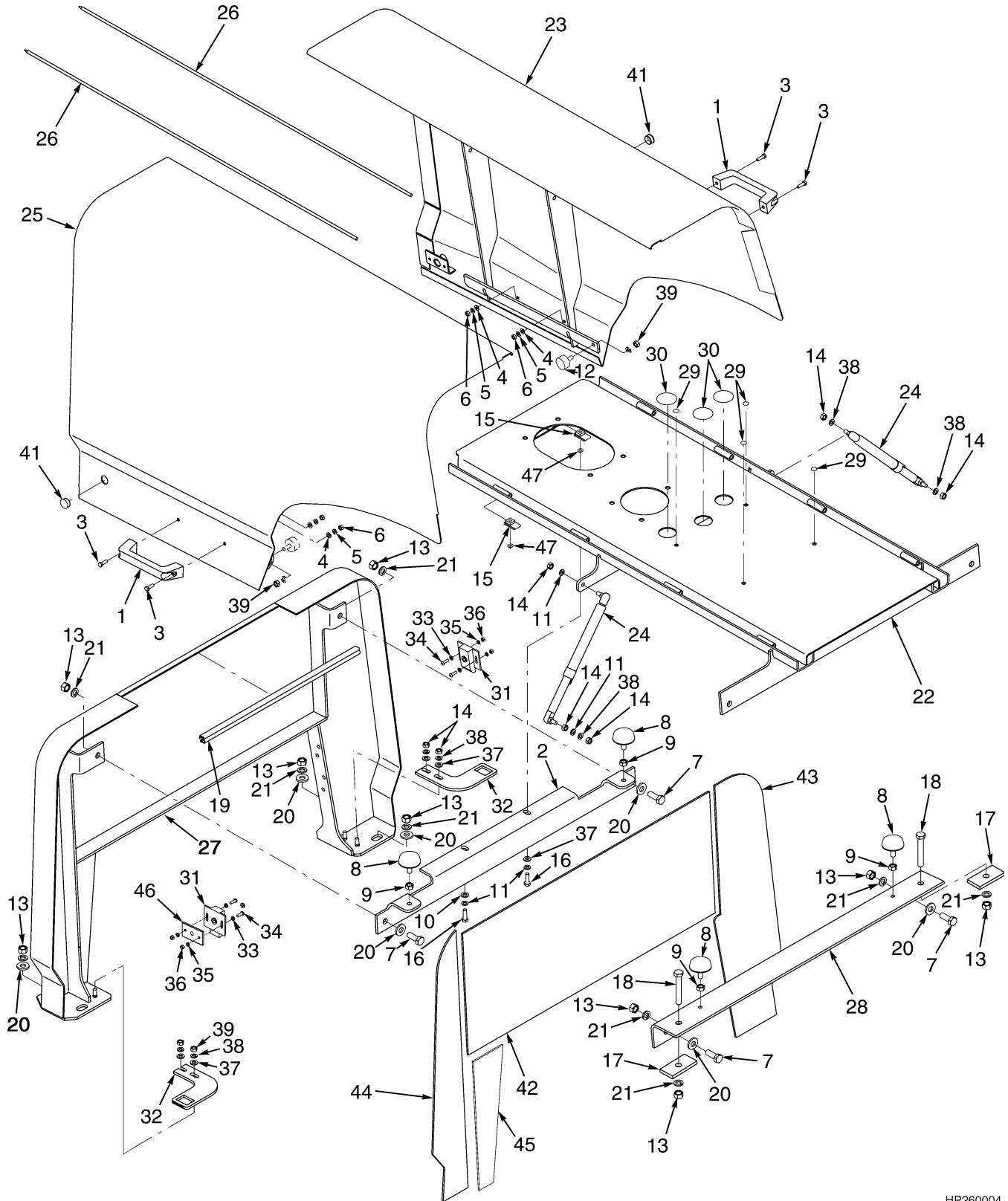

HP260004

HOOD

ITEM	PART NO.	DESCRIPTION	QTY
1	362030	Handle	2
2	1477508	Bracket.....	1
3	292501	Capscrew.....	4
4	320156	Washer	4
5	292680	Lockwasher.....	4
6	136687	Nut	4
7	292528	Capscrew.....	4
8	1479870	Screw (Stop).....	4
9	136692	Nut	4
10	320157	Washer	2
11	292681	Lockwasher.....	4
12	1489092	Screw (Stop).....	2
13	216877	Nut	10
14	239503	Nut	4
15	376397	Nut	2
16	18498	Capscrew.....	2
17	1479871	Washer	2
18	292535	Capscrew.....	AR
19	300088	Seal (Door) (Door)	8
20	320162	Washer	8
21	292683	Lockwasher.....	10
22	b 1554210	Channel	1
22	a 1554209	Channel	1
23	b 1478957	Hood (RH)	1
23	a 1478958	Hood (RH)	1
24	376300	Gas Spring.....	2
25	b 1479059	Hood (LH)	1
25	a 1479060	Hood (LH)	1
26	b 1476660	Rod	2
26	a 1476661	Rod	1
27	1489401	Support.....	1
28	1477512	Bracket.....	1
29	1494868	Plug (Without Air Conditioner)	4
30	1494869	Plug (Without Air Conditioner)	3
31	1382332	Latch	2
32	1494480	Bracket.....	2
33	320155	Washer	4
34	296155	Capscrew.....	4
35	292679	Lockwasher.....	4
36	292668	Nut	4
37	320160	Washer	4
38	292682	Lockwasher.....	4
39	136692	Nut	4
40	c 1382766	Wrench	1
41	309666	Plug (Non-EEC).....	2
42	1489402	Liner.....	1
43	1488424	Liner (RH).....	1
44	1488715	Liner (LH).....	1
45	c 1488716	Liner.....	1
46	1494642	Shim	AR
46	1494643	Shim	AR

HOOD

ITEM	PART NO.	DESCRIPTION	QTY
46	1494645	Shim	AR
47	320158	Washer	AR

FOOTNOTES:

- a H10.00XM-H12.00XM
- b H8.00XM-H9.00XM
- c Not Illustrated

HYSTER

NOTES

COUNTERWEIGHT (Figure 1-3)

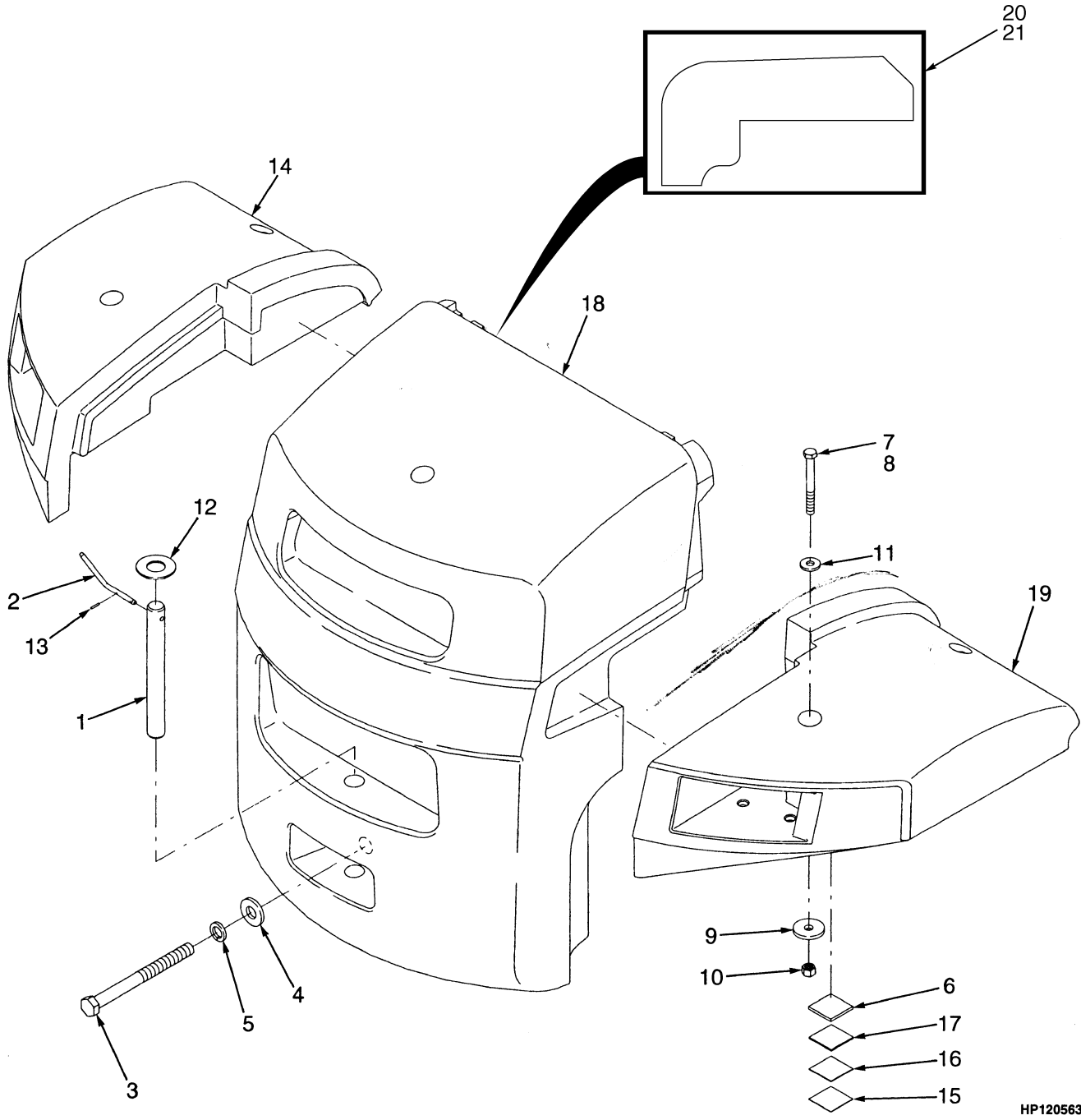

HP120563

COUNTERWEIGHT

ITEM	PART NO.	DESCRIPTION	QTY
1	1467696	Tow Pin	2
2	1495368	Grip	2
3	376319	Capscrew	2
4	149531	Washer	2
5	15168	Lockwasher	2
6	1475214	Shim	2
7	280472	Sealant	2
8	292597	Capscrew	4
9	1475872	Washer	4
10	316829	Nut	4
11	1301086	Washer	4
12	15189	Washer	2
13	302440	Pin	2
14	b 2038853	Fender (LH)	1
14	a 2038855	Fender (LH)	1
15	1475211	Shim	2
16	1475212	Shim	2
17	1475213	Shim	2
18	b 1467624	Counterweight	1
18	a 1467625	Counterweight	1
19	b 2038854	Fender (RH)	1
19	a 2038856	Fender (RH)	1
20	1532632	Liner (LH)	1
21	1532633	Liner (RH)	1

FOOTNOTES:**a** H10.00XM-H12.00XM**b** H8.00XM-H9.00XM

FLOOR PLATES AND COVERS (Figure 1-4) (⇒S/N F007E-02438A)

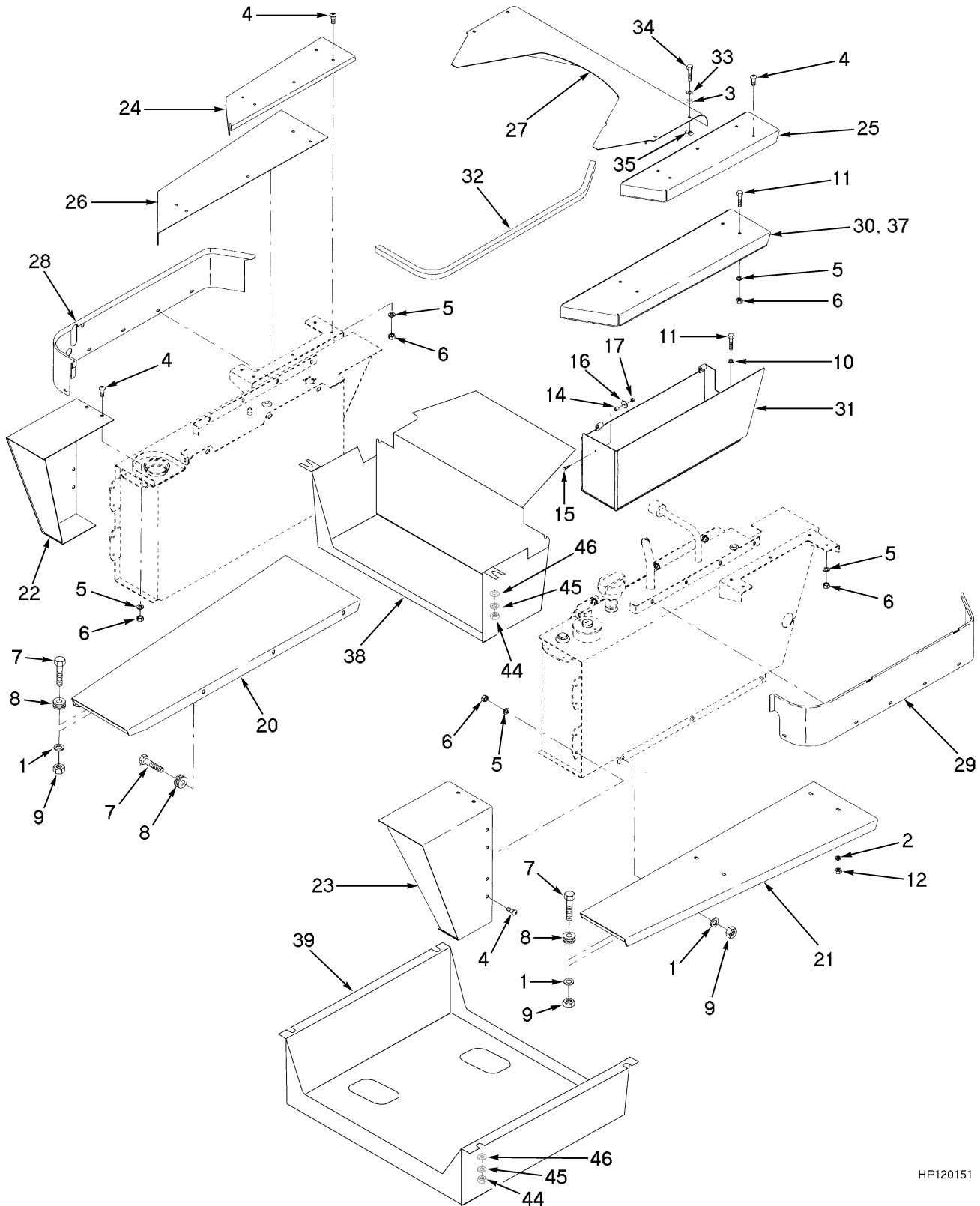

HP120151

FLOOR PLATES AND COVERS

(⇒S/N F007E-02438A)

ITEM	PART NO.	DESCRIPTION	QTY
1	320162	Washer	46
2	292683	Lockwasher.....	3
3	292681	Lockwasher.....	3
4	296173	Capscrew.....	15
5	292682	Lockwasher.....	30
6	292655	Nut	30
7	246001	Capscrew.....	20
8	216735	Grommet.....	20
9	300937	Locknut	20
10	320160	Washer	8
11	287854	Capscrew.....	8
12	136692	Nut	8
13	16257	Screw.....	1
14	1335831	Bushing.....	1
15	287816	Capscrew.....	1
16	1335832	Washer	1
17	313805	Nut	1
18	288762	Tape (Foam)	AR
19	1319189	Spring (Latch).....	1
20	a 1472660	Running Board (LH).....	1
20	c 1473302	Running Board (LH).....	1
21	a 1472664	Running Board (RH).....	1
21	c 1473304	Running Board (RH).....	1
22	c 1473310	Extension.....	1
22	a 1484244	Extension.....	1
23	c 1473314	Extension.....	1
23	a 1484247	Extension.....	1
24	1475488	Step	1
25	1475489	Step	1
26	1477099	Step	1
27	1485265	Cover	1
28	1485263	Panel (LH).....	1
29	1485264	Panel (RH).....	1
30	1471294	Cover (Battery Box)	1
31	1471296	Battery Box	1
32	1491360	Seal	AR
33	320158	Washer	14
34	296167	Capscrew.....	14
35	1480237	Clip Nut.....	14
36	d 375295	Trim	2
37	1494649	Step	1
38	b 1515431	Cover (Rear)	1
39	b 1515433	Cover (Bottom)	1
40	b 1516035	Liner.....	1
41	b 1516036	Liner.....	1
42	b 1516037	Liner.....	1
43	b 1516038	Liner.....	1
44	b 136692	Nut	8

FLOOR PLATES AND COVERS (⇒S/N F007E-02438A)

ITEM	PART NO.	DESCRIPTION	QTY
45	b 292682	Lockwasher.....	8
46	b 320160	Washer	8

FOOTNOTES:

- a H10.00XM-H12.00XM
- b H12.00XM
- c H8.00XM-H9.00XM
- d Not Illustrated

FLOOR PLATES AND COVERS (Figure 1-5) (S/N F007E-02439A⇒)

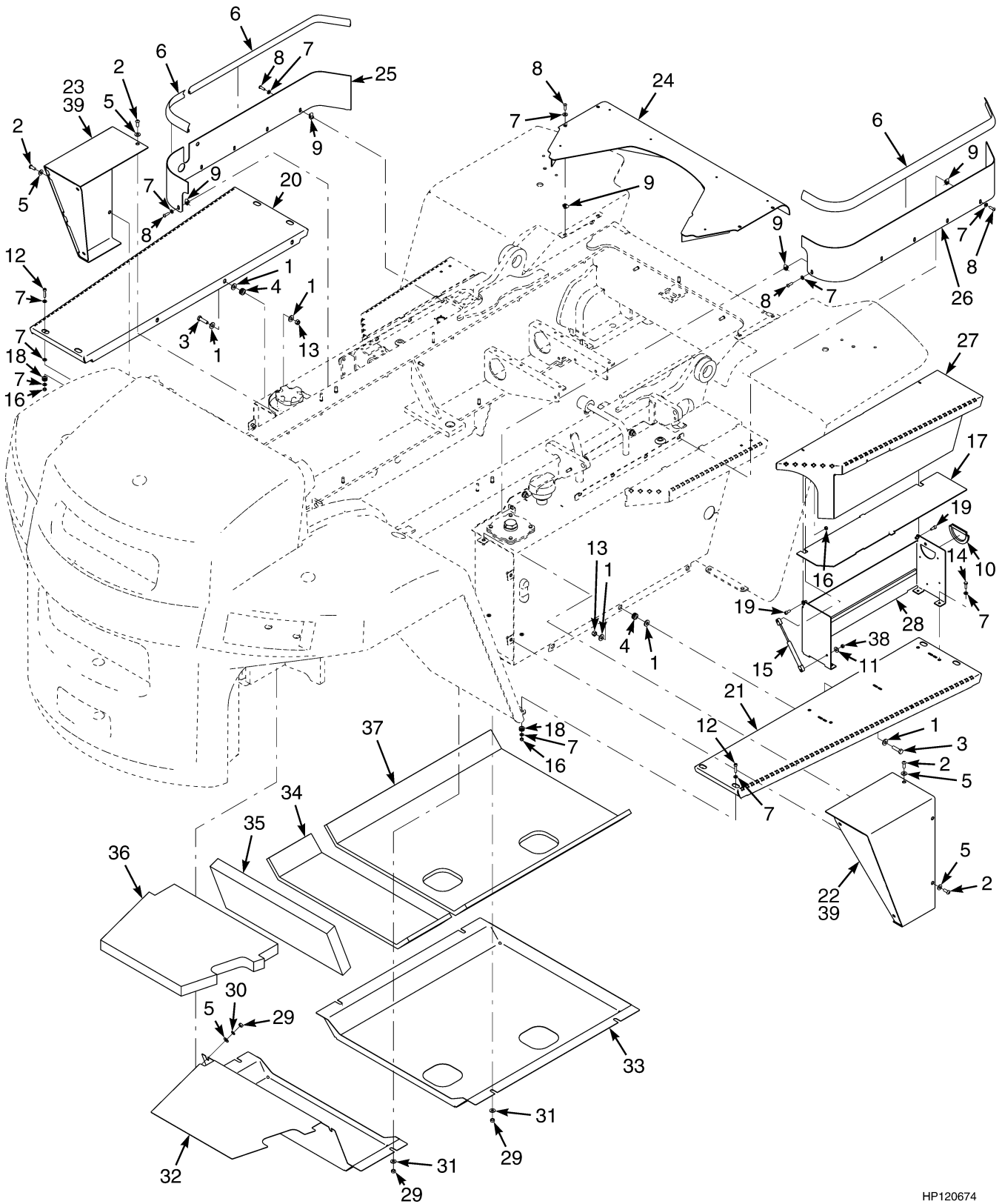

HP120674

FLOOR PLATES AND COVERS
(S/N F007E-02439A⇒)

ITEM	PART NO.	DESCRIPTION	QTY
1	320162	Washer	18
2	296173	Capscrew.....	6
3	287837	Capscrew.....	6
4	216735	Grommet.....	6
5	320160	Washer	6
6	1491360	Seal	AR
7	320158	Washer	42
8	296167	Capscrew.....	14
9	1480237	Clip Nut.....	14
10	325983	Trim	AR
11	292681	Lockwasher.....	2
12	296013	Capscrew.....	8
13	302402	Locknut	6
14	136749	Capscrew.....	4
15	1532341	Gas Spring.....	1
16	302400	Locknut	10
17	2071326	Cover	1
18	91946	Grommet.....	8
19	1529665	Capscrew.....	2
20	c 1529813	Running Board (LH).....	1
20	a 1529815	Running Board (LH).....	1
21	c 1529814	Running Board (RH)	1
21	a 1529816	Running Board (RH)	1
22	c 1532189	Extension (RH)	1
22	a 1532448	Extension (RH)	1
23	c 1532188	Extension (LH)	1
23	a 1532446	Extension (LH)	1
24	1485265	Cover	1
25	1485263	Panel (LH).....	1
26	1485264	Panel (RH)	1
27	1529751	Cover (Battery Box)	1
28	1532202	Battery Box	1
29	b 136692	Nut	8
30	b 292682	Lockwasher.....	8
31	b 320160	Washer	8
32	b 1515431	Cover	1
33	b 1562200	Cover	1
34	b 1516035	Liner.....	1
35	b 1516036	Liner.....	1
36	b 1516037	Liner.....	1
37	b 1516038	Liner.....	1
38	329069	Nut	2
39	288762	Tape.....	AR

FOOTNOTES:

- a** H10.00XM-H12.00XM
- b** H12.00XM
- c** H8.00XM-H9.00XM

CAB AND ATTACHING PARTS (Figure 1-6)

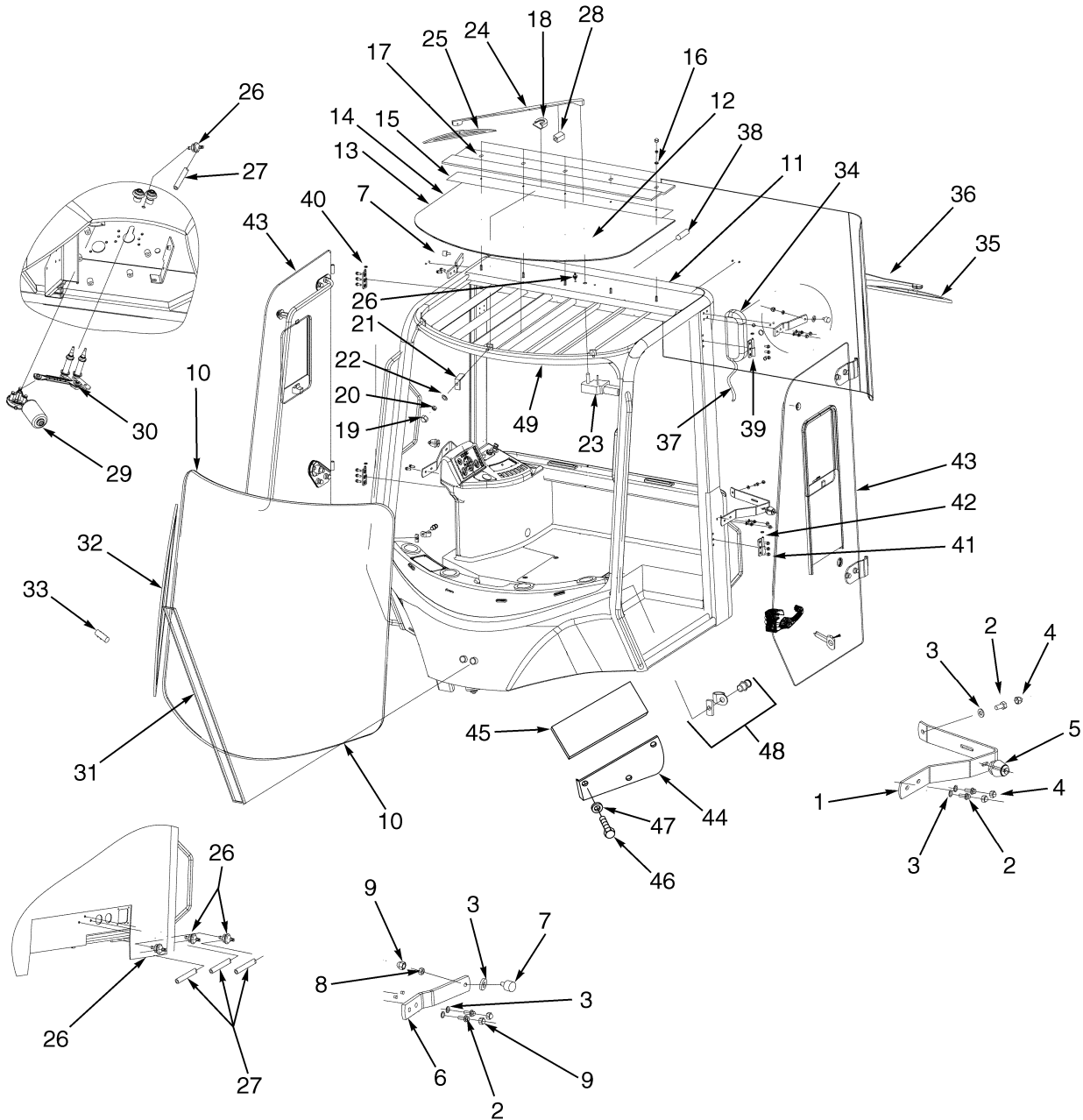

HP120624

Thank you so much for reading.
Please click the “Buy Now!”
button below to download the
complete manual.



After you pay.

You can download the most
perfect and complete manual in
the world immediately.

Our support email:

ebooklibonline@outlook.com