

PARTS MANUAL

FORTENS

**S2.0FT-S3.5FT
(F187)**

CUSTOMER EDITION

HYSTER

SECTIONS

1	FRAME
2	ENGINES
3	FUEL SYSTEM
4	ELECTRICAL SYSTEM
5	TRANSMISSION
6	DRIVE AXLE
7	STEERING SYSTEM
8	BRAKE SYSTEM
9	HYDRAULIC SYSTEM
10	MAST-TWO STAGE LIMITED FREE-LIFT
11	MAST-TWO STAGE FULL FREE-LIFT
12	MAST-THREE STAGE FULL FREE-LIFT
13	MAST-FOUR STAGE FULL FREE-LIFT
14	OPTIONS
15	NUMERICAL INDEX

TABLE OF CONTENTS

DESCRIPTION	PAGE
A	
ACCUMULATOR	14-26
AIR CLEANER	
GM 2.4L	3-10
LPG	
MAZDA 2.0L AND 2.2L	3-4
AIR FILTER ASSEMBLY	3-14
ALTERNATOR MOUNTING	
GM 2.4L	2-46
ASSEMBLED ENGINE	
GM 2.4L	
SHEET 1 OF 4	2-38
SHEET 2 OF 4	2-40
SHEET 3 OF 4	2-42
SHEET 4 OF 4	2-44
AUXILIARY TUBE EXTENSION KIT	
FOUR STAGE FULL FREE-LIFT	14-24
TWO AND THREE STAGE FULL FREE-LIFT	14-22
AUXILIARY ONE SECTION	
ELECTRONIC CONTROL	
THREE AND FOUR FUNCTION	9-40
AUXILIARY SECTIONS ONE AND TWO	
MANUAL CONTROL VALVE	
THREE AND FOUR FUNCTION	9-28
AUXILIARY TUBE EXTENSION KIT	
TWO STAGE LIMITED FREE-LIFT	14-20
AUXILIARY TWO SECTION	
ELECTRONIC CONTROL	
FOUR FUNCTION	9-42
B	
BACK-UP ALARM	14-4
BRAKE ASSEMBLY	8-6
BRAKE LINKAGE	
DUAL PEDAL	8-4
SINGLE PEDAL	8-2
C	
CAMSHAFT AND VALVES	
MAZDA 2.0L AND 2.2L	2-16
CAMSHAFT, CYLINDER HEAD AND MANIFOLDS	
GM 2.4L	2-54
CARRIAGE	
FOUR STAGE FULL FREE-LIFT	13-18
THREE STAGE FULL FREE-LIFT	12-24
TWO STAGE FULL FREE-LIFT	11-14
TWO STAGE LIMITED FREE LIFT	10-12
CONTROL LEVER LABELS	1-22
CONTROL VALVE	
TRANSMISSION	5-26
CONTROL VALVE ASSEMBLY	

TABLE OF CONTENTS (Continued)

DESCRIPTION	PAGE
C (continued)	
ELECTRONIC CONTROL	
THREE AND FOUR FUNCTION	9-32
MANUAL CONTROL	
THREE AND FOUR FUNCTION	9-24
CONTROL VALVE ASSEMBLY, LIFT AND LOWER	
ELECTRONIC CONTROL	
THREE AND FOUR FUNCTION	9-34
COOLING	
GM 2.4L	2-32
MAZDA 2.0L AND 2.2L, LPG	2-4
COOLING MANIFOLD AND ATTACHING PARTS	
GM 2.4L	2-47
COUNTERWEIGHT	1-8
COWL ELECTRICAL	4-12
COWL MOUNT	1-7
CRANK, PISTONS, AND OIL PAN	
GM 2.4L	2-50
CRANKSHAFT AND PISTONS	
MAZDA 2.0L AND 2.2L	2-18
CYLINDER BLOCK	
MAZDA 2.0L AND 2.2L	2-12
CYLINDER HEAD	
MAZDA 2.0L AND 2.2L	2-14
D	
DISTRIBUTOR	
MAZDA 2.0L AND 2.2L	4-8
DRIVE AXLE	6-2
DRIVE TIRES AND WHEELS	
S2.0-2.5FT	6-5
S3.0FT	6-6
S3.5FT	6-7
E	
ELECTRICAL SYSTEM	
CHASSIS	4-2
ELECTRO HYDRAULIC POPPET VALVE	
ELECTRONIC CONTROL	
LIFT AND LOWER	9-38
ELECTRONIC LEVER LABELS	1-24
ENGINE ELECTRICAL COMPONENTS	
MAZDA 2.0L AND 2.2L	4-6
ENGINE ELECTRICAL SYSTEM	
GM 2.4L	4-10
MAZDA 2.0L AND 2.2L	4-4
ENGINE FUEL SYSTEM AND EMISSION CONTROL	
MAZDA 2.0L AND 2.2L	2-28
ENGINE MOUNT	
GM 2.4L	2-30

TABLE OF CONTENTS (Continued)

DESCRIPTION	PAGE
E (continued)	
MAZDA 2.0L AND 2.2L	2-2
EXHAUST	
GM 2.4L	2-34
MAZDA 2.0L AND 2.2L, LPG	2-10
F	
FENDERS	1-6
FIRE EXTINGUISHER	14-7
FLOORPLATES AND COVERS	1-4
FLYWHEEL AND HOUSING	
GM 2.4L	2-36
MAZDA 2.0L AND 2.2L	2-8
FORK.....	1-28
OPTIONAL.....	1-29
FORWARD CLUTCH	
SINGLE SPEED TRANSMISSION	5-12
FORWARD CLUTCH, HIGH	
DUAL SPEED TRANSMISSION	5-22
FORWARD CLUTCH, LOW	
DUAL SPEED TRANSMISSION	5-20
FREE LIFT	
FOUR STAGE FULL FREE-LIFT	13-14
FREE LIFT CYLINDER	
TWO STAGE FULL FREE-LIFT	11-12
FREE LIFT CYLINDERS	
FOUR STAGE FULL FREE-LIFT	13-16
THREE STAGE FULL FREE-LIFT	12-20
FREE-LIFT	
THREE STAGE FULL FREE-LIFT	12-16
TWO STAGE FULL FREE-LIFT	11-10
FUEL SYSTEM	
LPG	
GM 2.4L.....	3-6
MAZDA (2.0L AND 2.2L)	3-2
FULL SUSPENSION SEAT	
WITH AND WITHOUT ELECTRONIC CONTROLS	1-16
FULL SUSPENSION SWIVEL SEAT	
WITH AND WITHOUT ELECTRONIC CONTROLS	1-18
G	
GEAR PUMP	
GM 2.4L	9-10
MAZDA 2.0L AND 2.2L	9-8
H	
HAND LEVERS	
FOUR FUNCTION	
WITH DETENTED LEVERS.....	9-22
WITHOUT DETENTED LEVERS	9-20

TABLE OF CONTENTS (Continued)

DESCRIPTION	PAGE
H (continued)	
THREE FUNCTION	
WITH DETENTED LEVERS.....	9-18
WITHOUT DETENTED LEVERS.....	9-16
HEADER HOSE	
TWO STAGE FULL FREE-LIFT.....	11-16
TWO STAGE LIMITED FREE LIFT.....	10-14
HEADER HOSES	
FOUR STAGE FULL FREE-LIFT.....	13-20
THREE STAGE FULL FREE-LIFT.....	12-26
HOOD.....	1-2
HYDRAULIC COOLER	
THREE AND FOUR FUNCTION	
OPTIONAL.....	9-6
HYDRAULIC FILTER.....	9-12
HYDRAULIC SUPPLY AND RETURN.....	9-4
I	
INNER MAST	
FOUR STAGE FULL FREE-LIFT.....	13-8
THREE STAGE FULL FREE-LIFT.....	12-6
TWO STAGE FULL FREE-LIFT.....	11-4
TWO STAGE LIMITED FREE LIFT.....	10-4
INSTRUMENT CLUSTER.....	4-15
INTAKE AND EXHAUST MANIFOLDS	
MAZDA 2.0L AND 2.2L.....	2-24
INTEGRAL SIDE-SHIFT CARRIAGE	
THREE AND FOUR STAGE FULL FREE-LIFT.....	14-12
TWO STAGE FULL FREE-LIFT.....	14-10
TWO STAGE LIMITED FREE-LIFT.....	14-8
INTEGRAL SIDE-SHIFT CYLINDER.....	14-14
INTEGRAL SIDE-SHIFT HYDRAULIC HOSES	
FOUR STAGE FULL FREE-LIFT.....	14-18
TWO AND THREE STAGE FULL FREE-LIFT.....	14-17
TWO STAGE LIMITED FREE-LIFT.....	14-16
INTERMEDIATE MAST	
THREE STAGE FULL FREE-LIFT.....	12-4
INTERMEDIATE MAST THREE	
FOUR STAGE FULL FREE-LIFT.....	13-6
INTERMEDIATE MAST TWO	
FOUR STAGE FULL FREE-LIFT.....	13-4
J	
JOYSTICK	
AND	
ELECTRONIC MINI-LEVERS.....	4-16
JOYSTICK LABELS.....	1-26

TABLE OF CONTENTS (Continued)

DESCRIPTION	PAGE
L	
LABELS	1-20
LIFT AND TILT VALVE ASSEMBLY	
MANUAL CONTROL VALVE	
THREE AND FOUR FUNCTION	9-26
LOAD BACKREST EXTENSION	1-30
LPG REGULATOR	
GM 2.4L	3-8
LPG TANK BRACKET	
SWING OUT	3-18
SWING OUT/DROP DOWN	3-20
M	
MAIN CYLINDERS	
LEFT HAND	
FOUR STAGE FULL FREE-LIFT	13-12
RIGHT HAND	
FOUR STAGE FULL FREE-LIFT	13-13
THREE STAGE FULL FREE-LIFT	12-12
MAIN LIFT	
FOUR STAGE FULL FREE-LIFT	13-10
THREE STAGE FULL FREE-LIFT	12-8
TWO STAGE FULL FREE-LIFT	11-6
TWO STAGE LIMITED FREE LIFT	10-6
MAIN LIFT CYLINDER	
TWO STAGE LIMITED FREE LIFT	10-8
MAIN LIFT CYLINDERS	
LEFT HAND	
TWO STAGE FULL FREE-LIFT	11-9
RIGHT HAND	
TWO STAGE FULL FREE-LIFT	11-8
MAST ELECTRICAL	4-22
MIRRORS	14-6
MONOTROL PEDAL	3-24
N	
NON SUSPENSION SEAT	
WITHOUT ELECTRONIC CONTROLS	1-12
O	
OIL PUMP AND FILTER	
MAZDA 2.0L AND 2.2L	2-22
OUTER MAST	
FOUR STAGE FULL FREE-LIFT	13-2
THREE STAGE FULL FREE-LIFT	12-2
TWO STAGE FULL FREE-LIFT	11-2
TWO STAGE LIMITED FREE LIFT	10-2
OUTLET SECTION	
ELECTRONIC CONTROL	
THREE AND FOUR FUNCTION	9-44
MANUAL CONTROL VALVE	

TABLE OF CONTENTS (Continued)

DESCRIPTION	PAGE
O (continued)	
THREE AND FOUR FUNCTION	9-30
OVERHEAD GUARD	1-10
P	
PARK BRAKE	8-8
POWER DISTRIBUTION MODULE	4-14
PRE-CLEANER AND MOUNT	3-12
R	
REMOTE OIL FILTER	
GM 2.4L	2-48
REVERSE CLUTCH	
DUAL SPEED TRANSMISSION	5-24
SINGLE SPEED TRANSMISSION	5-14
S	
SEMI SUSPENSION SEAT	
WITH AND WITHOUT ELECTRONIC CONTROLS	1-14
STEER TIRES AND WHEELS	7-12
STEERING AXLE	7-8
STEERING COLUMN ASSEMBLY	7-4
STEERING CONTROL UNIT	7-6
STEERING CYLINDER	7-10
STEERING SYSTEM	7-2
STROBE LIGHT	14-2
T	
THROTTLE BODY AND ATTACHING PARTS	
GM 2.4L	3-16
THROTTLE LINKAGE	3-22
TILT AND AUXILIARY HOSES	9-14
TILT CYLINDER AND MAST INSTALLATION	9-46
TILT CYLINDERS	
S2.0-2.5FT	9-48
S3.0-3.5FT	9-50
TILT SECTION	
ELECTRONIC CONTROL	
THREE AND FOUR FUNCTION	9-36
TIMING GEAR AND OIL PAN	
MAZDA 2.0L AND 2.2L	2-20
TORQUE CONVERTER	
GM 2.4L	
LPG	5-4
MAZDA 2.0L AND 2.2L	
LPG	5-3
TRANSMISSION	
DUAL SPEED	
SHEET ONE OF TWO	5-16
SHEET TWO OF TWO	5-18

TABLE OF CONTENTS (Continued)

DESCRIPTION	PAGE
T (continued)	
SINGLE SPEED	
SHEET ONE OF TWO	5-8
SHEET TWO OF TWO	5-10
TRANSMISSION COOLING	
WITH AIR COOLER	
GM 2.4L.....	5-6
WITHOUT AIR COOLER	
MAZDA 2.0L AND 2.2L	5-5
TRANSMISSION ELECTRICAL SYSTEM	4-20
TRANSMISSION MOUNT	5-2
W	
WATER PUMP	
MAZDA 2.0L AND 2.2L	2-26
WIRE HARNESS	
CHASSIS	
GM 2.4L.....	4-28
MAZDA (2.0L AND 2.2L)	4-24
COWL	4-32
DUAL SPEED TRANSMISSION	4-46
ELECTRONIC CONTROL VALVE	
FOUR FUNCTION.....	4-42
THREE FUNCTION.....	4-40
ENGINE	
GM 2.4L.....	4-38
MAZDA 2.0L AND 2.2L	4-36
HYDRAULIC OIL COOLER	4-50
LIGHTS	4-48
SINGLE SPEED TRANSMISSION	4-44
WORK, REAR DRIVE, AND BRAKE/TAIL LIGHTS	4-18

SECTION 1
FRAME

DESCRIPTION	PAGE
CONTROL LEVER LABELS.....	1-22
COUNTERWEIGHT	1-8
COWL MOUNT.....	1-7
ELECTRONIC LEVER LABELS	1-24
FENDERS	1-6
FLOORPLATES AND COVERS	1-4
FORK.....	1-28
OPTIONAL.....	1-29
FULL SUSPENSION SEAT	
WITH AND WITHOUT ELECTRONIC CONTROLS	1-16
FULL SUSPENSION SWIVEL SEAT	
WITH AND WITHOUT ELECTRONIC CONTROLS	1-18
HOOD.....	1-2
JOYSTICK LABELS.....	1-26
LABELS.....	1-20
LOAD BACKREST EXTENSION.....	1-30
NON SUSPENSION SEAT	
WITHOUT ELECTRONIC CONTROLS	1-12
OVERHEAD GUARD.....	1-10
SEMI SUSPENSION SEAT	
WITH AND WITHOUT ELECTRONIC CONTROLS	1-14

HOOD (Figure 1-1)

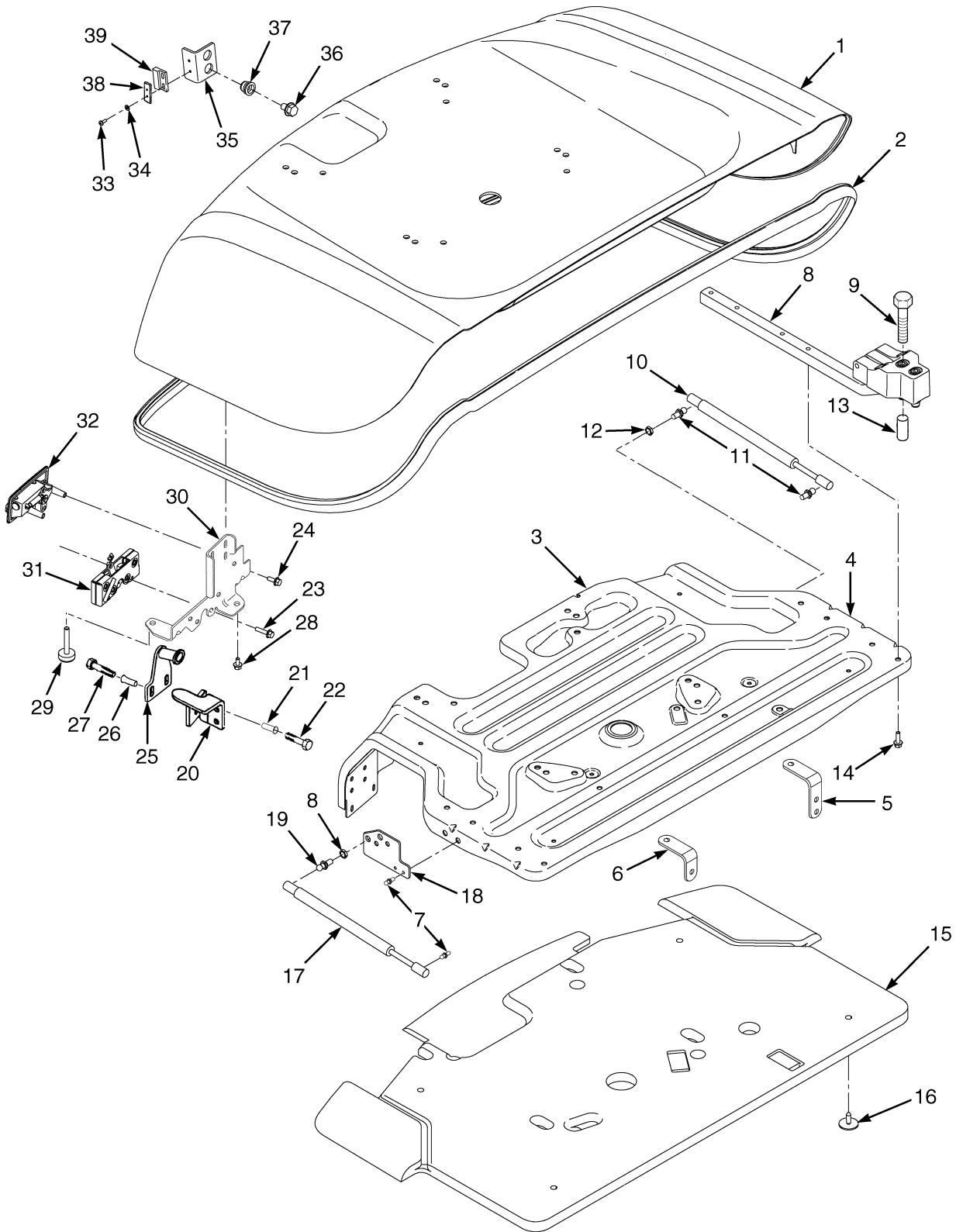

BP120150

HOOD

ITEM	PART NO.	DESCRIPTION	QTY
1	ab 1564005	Hood	1
1	b 1585588	Hood	1
1	1569171	Hood (Vented).....	1
1	b 1585874	Hood (Vented).....	1
2	1578698	Seal (Hood)	1
3	1564009	Reinforcement Assembly.....	1
4	1608874	Reinforcement	1
5	1585590	Bracket	1
6	1582370	Bracket	1
7	1608879	Huck Bolt	6
8	1547970	Hinge	2
9	286032	Capscrew.....	4
10	1560647	Gas Spring (LH).....	1
11	1563369	Ball Stud	3
12	329069	Nut	2
13	1530244	Insert.....	4
14	1583611	Capscrew.....	10
15	1548493	Liner.....	1
16	1304971	Fastener.....	4
17	1563836	Gas Spring (RH)	1
18	1608875	Bracket.....	2
19	1606659	Ball Stud	1
20	1595826	Bumper Rest.....	1
21	1530244	Insert.....	4
22	286032	Capscrew.....	4
23	1527878	Capscrew.....	4
24	1527876	Capscrew.....	4
25	1580794	Striker Bolt	1
26	1530243	Insert.....	2
27	1527881	Capscrew.....	2
28	1534417	Capscrew.....	6
29	1585581	Bumper (Hood)	2
30	1580293	Plate	1
31	1582286	Latch Rotor	1
32	1582287	Handle	1
33	302010	Screw.....	4
34	320152	Washer	4
35	1527228	Bracket.....	2
36	1583611	Capscrew.....	2
37	1531557	Insert.....	2
38	1585765	Plate	1
39	1565545	Magnet.....	1
	1347045	Fastener (Not Illustrated)	8
	1561015	Grommet (Not Illustrated)	1

FOOTNOTES:**a** Non-Vented**b** Used With Swivel Seat

FLOORPLATES AND COVERS (Figure 1-2)

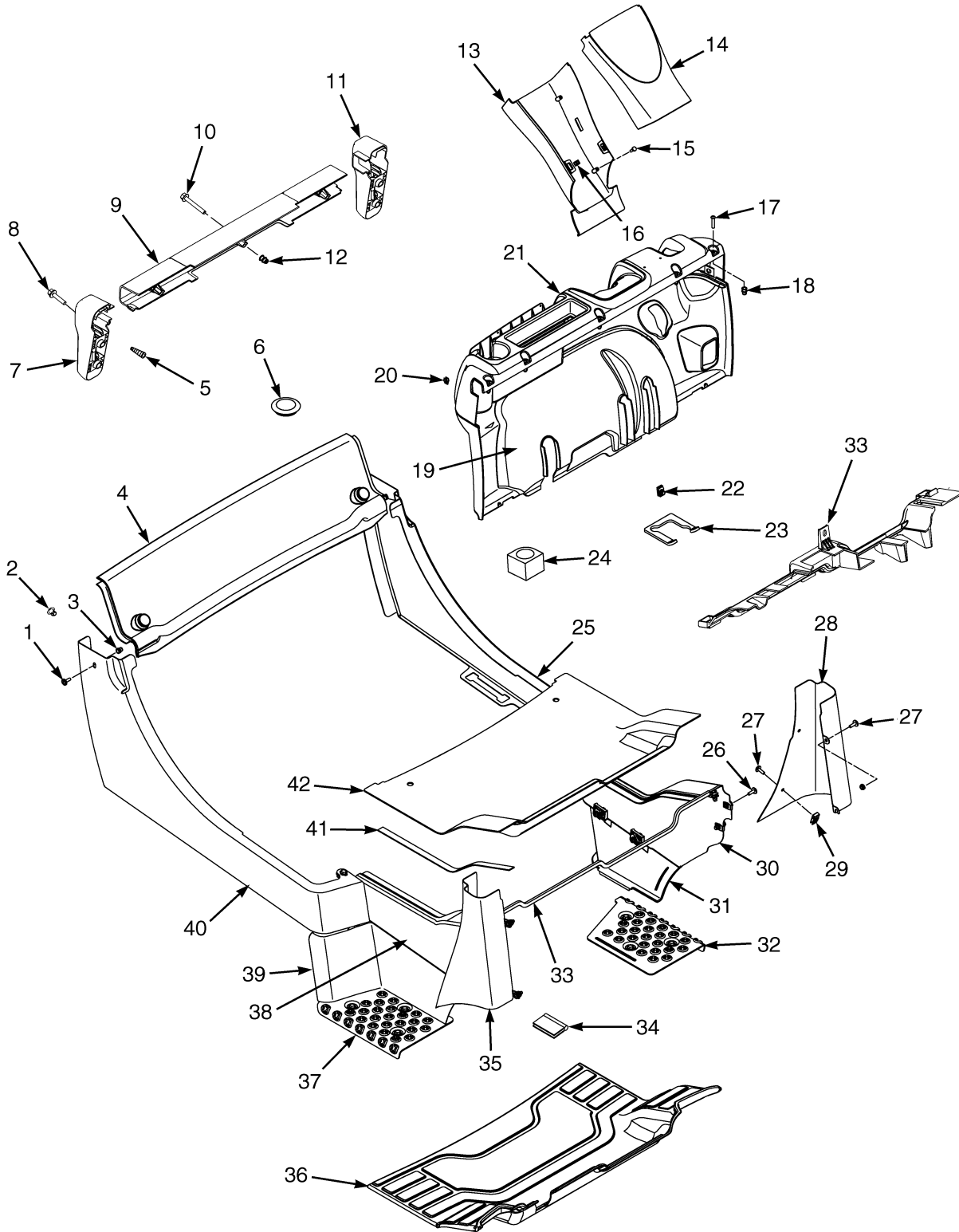

BP120125

FLOORPLATES AND COVERS

ITEM	PART NO.	DESCRIPTION	QTY
1	1530019	Screw.....	2
2	1581079	Plug	4
3	1531558	Insert.....	2
4	1547464	Cover Assembly (Radiator).....	1
4	1544936	Seal (RH).....	1
4	1544937	Seal (LH)	1
5	1531558	Insert.....	4
6	2021395	Cap	2
7	2056823	Bracket (Tail Light) (RH)	1
8	1586495	Capscrew.....	4
9	2067455	Cover (Rear) (Crossmember).....	1
10	1540643	Capscrew.....	3
11	2056822	Bracket (Tail Light) (LH)	1
12	1531001	Insert.....	3
13	2065666	Cover (Steering Column) (Lower).....	1
14	2065668	Cover (Steering Column) (Upper).....	1
15	2027655	Screw.....	2
16	2065667	Clip	4
17	2071261	Capscrew.....	5
18	1531001	Insert.....	5
19	2071593	Panel (Kick) (Single Pedal).....	1
19	2071594	Panel (Kick) (Dual Pedal).....	1
20	2065667	Clip	4
21	1517418	Dash Assembly (E-Hydraulics).....	1
21	2065885	Dash	1
21	2070975	Cup Holder	1
21	1517419	Dash Assembly (Manual Valve).....	1
21	2065886	Dash	1
21	2070975	Cup Holder	1
22	1480237	Clip Nut.....	23
23	1581569	Seal	1
24	1530135	Grommet (RH)	1
25	1527940	Panel (Rear) (LH)	1
26	1583611	Capscrew.....	23
27	1530019	Screw.....	4
28	1564026	Cover (Fender) (LH).....	1
29	1350215	Nut (Foldover).....	4
30	1540859	Panel (Front) (LH)	1
31	1574271	Panel (Step) (LH).....	1
32	1519787	Plate (Tread) (LH)	1
33	1564396	Seal Plate Assembly.....	1
33	1529426	Seal	1
34	1582072	Trim Seal.....	2
35	1564028	Cover (Fender) (RH)	1
36	2072213	Floormat	1
37	1519788	Plate (Tread) (RH).....	1
38	1540869	Panel (Front) (RH)	1
39	1574273	Panel (Step) (RH)	1
40	1527946	Rear Panel (RH)	1
41	1564529	Seal	2
42	1509754	Floor Plate	1

FENDERS (Figure 1-3)

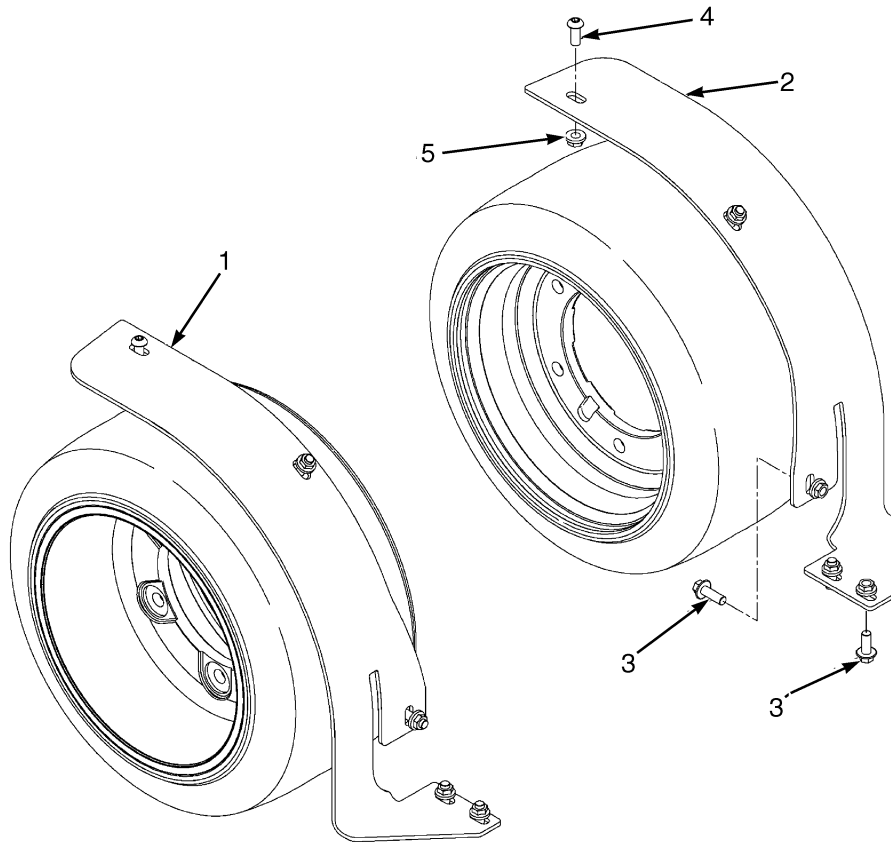

HP120731

ITEM	PART NO.	DESCRIPTION	QTY
1	a 1579429	Fender (LH)	1
1	b 1579428	Fender (LH)	1
2	a 1579426	Fender (RH).....	1
2	b 1579427	Fender (RH).....	1
3	1586630	Capscrew.....	8
4	2072664	Capscrew.....	2
5	1586432	Nut.....	10

FOOTNOTES:

- a 21 X 9 X 10.5
- b Wide Rim

COWL MOUNT (Figure 1-4)

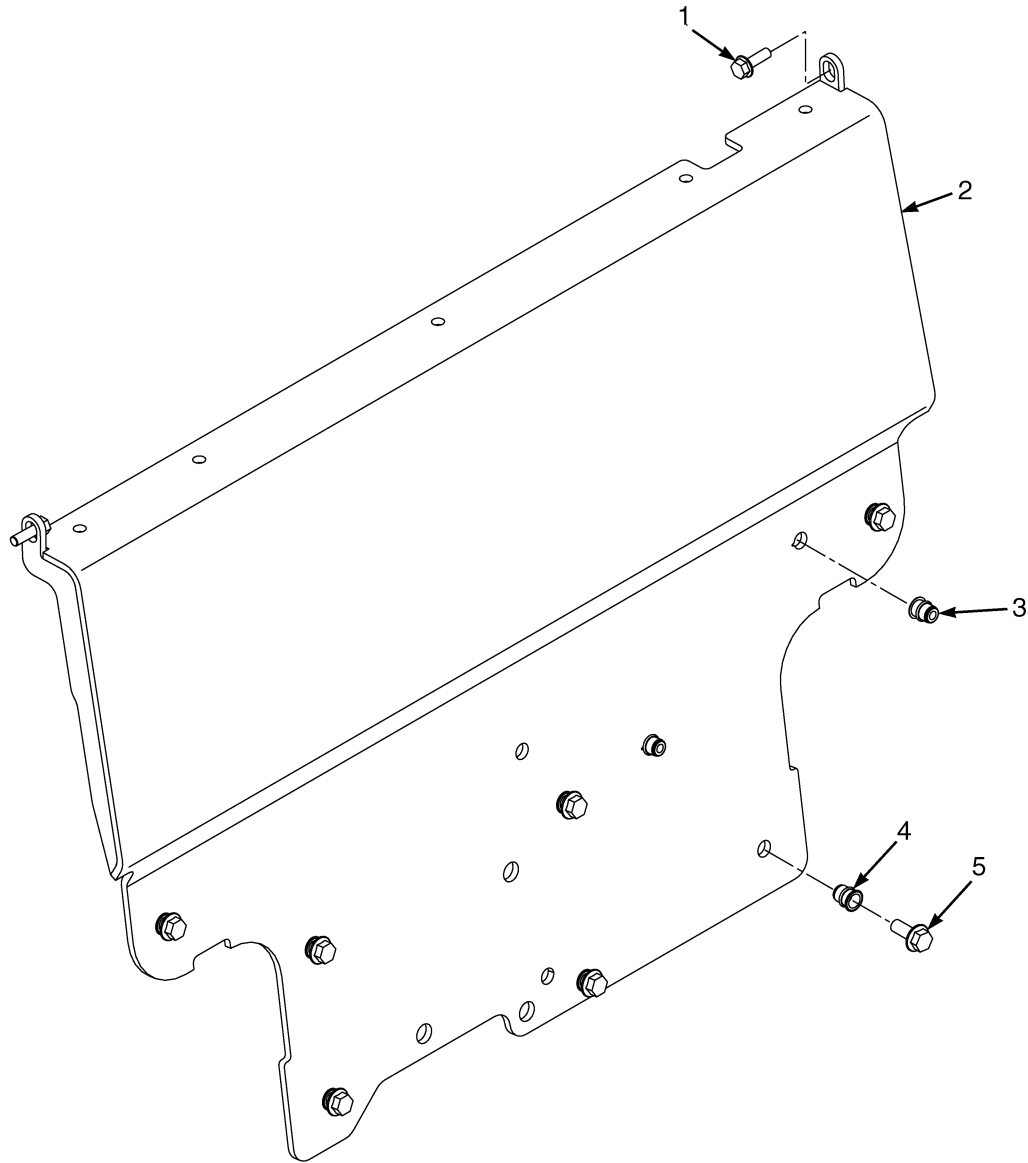

HP120730

ITEM	PART NO.	DESCRIPTION	QTY
1	1583611	Capscrew.....	2
2	1566545	Cowl.....	1
3	1530243	Insert.....	2
4	1530244	Insert.....	7
5	1605990	Capscrew.....	7

COUNTERWEIGHT (Figure 1-5)

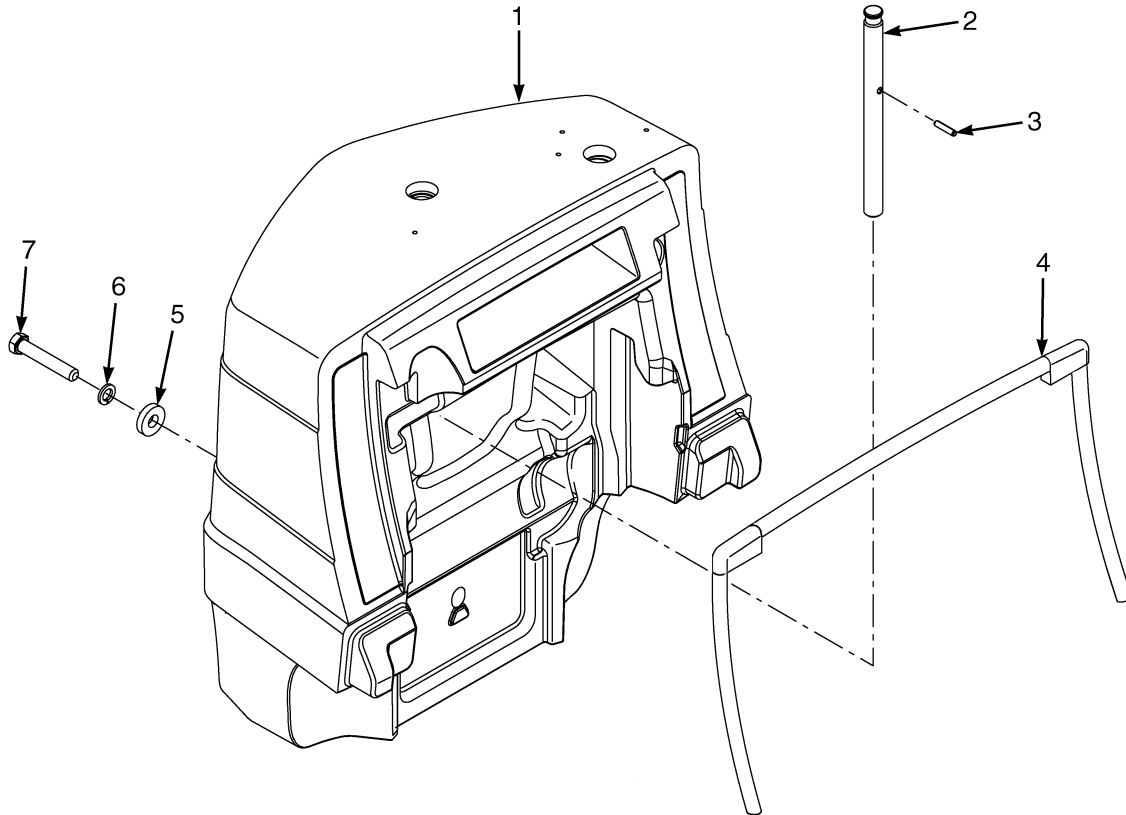

HP120727

COUNTERWEIGHT

ITEM	PART NO.	DESCRIPTION	QTY
1	1520879	Counterweight (S2.0FT)	1
1	1520880	Counterweight (S2.5FT)	1
1	1520882	Counterweight (S3.0FT)	1
1	1520883	Counterweight (S3.5FT)	1
2	1521190	Tow Pin	1
3	302492	Pin	1
4	1566649	Seal	1
5	1375214	Washer	1
6	292689	Lockwasher.....	1
7	292608	Capscrew (101,6 mm) (S2.0-2.5FT).....	1
7	292613	Capscrew (152,4 mm) (S3.0-3.5FT).....	1

OVERHEAD GUARD (Figure 1-6)

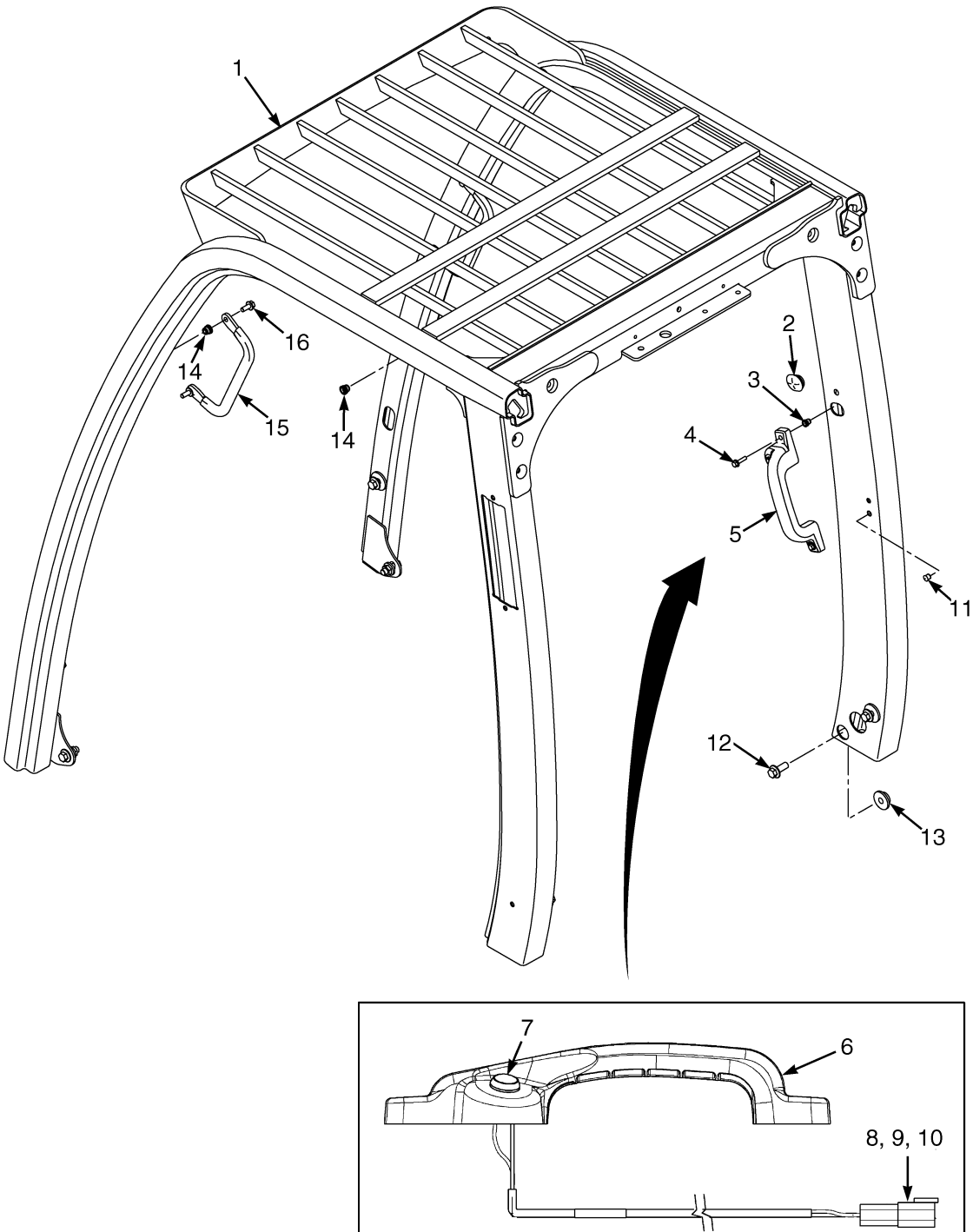

HP120732

OVERHEAD GUARD

ITEM	PART NO.	DESCRIPTION	QTY
1	1599203	Overhead Guard (High)	1
1	1599209	Overhead Guard (Low)	1
2	1558219	Grommet.....	2
3	1531558	Insert.....	2
4	1586495	Capscrew.....	2
5	2070223	Handle Assembly.....	1
6	2069454	Handle	1
7	1566726	Switch.....	1
8	1493465	Connector.....	1
9	1330414	Secondary Lock.....	1
10	1330437	Terminal (Pin)	2
11	1494888	Plug	2
12	1528889	Capscrew.....	8
13	1528888	Nut	2
14	1531557	Insert.....	4
15	1536813	Handle (Grab).....	1
16	1583611	Capscrew.....	2
	a 1599415	Plug	1

FOOTNOTES:

a Not Illustrated

NON SUSPENSION SEAT (Figure 1-7) WITHOUT ELECTRONIC CONTROLS

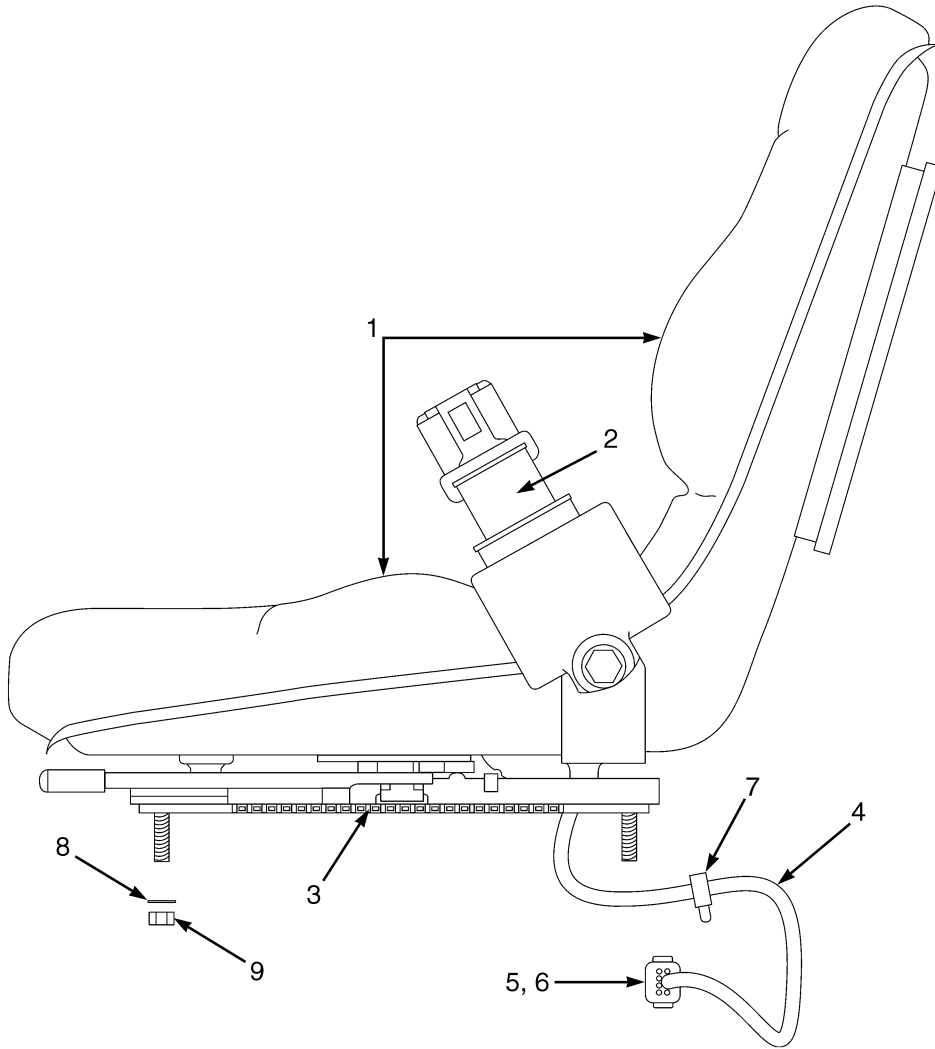

HP120851

NON SUSPENSION SEAT WITHOUT ELECTRONIC CONTROLS

ITEM	PART NO.	DESCRIPTION	QTY
	1593409	Non-Suspension Seat (Vinyl).....	1
	1593410	Non-Suspension Seat (Cloth).....	1
1	1563351	Cushions (Vinyl)	1
1	1563222	Cushions (Cloth).....	1
2	1598504	Seat Belt Kit.....	1
3	1459173	Slide Kit	1
4	1591652	Harness Kit.....	1
4	2075429	Wire Harness	1
4	2070392	Pigtail	1
5	1500912	Clip	1
6	1582464	Fastener	1
7	1500901	Clip	1
8	320158	Washer	4
9	191941	Nut.....	4
a	1563215	Sensor (Operator Presence)	1

FOOTNOTES:

a Not Illustrated

SEMI SUSPENSION SEAT (Figure 1-8) WITH AND WITHOUT ELECTRONIC CONTROLS

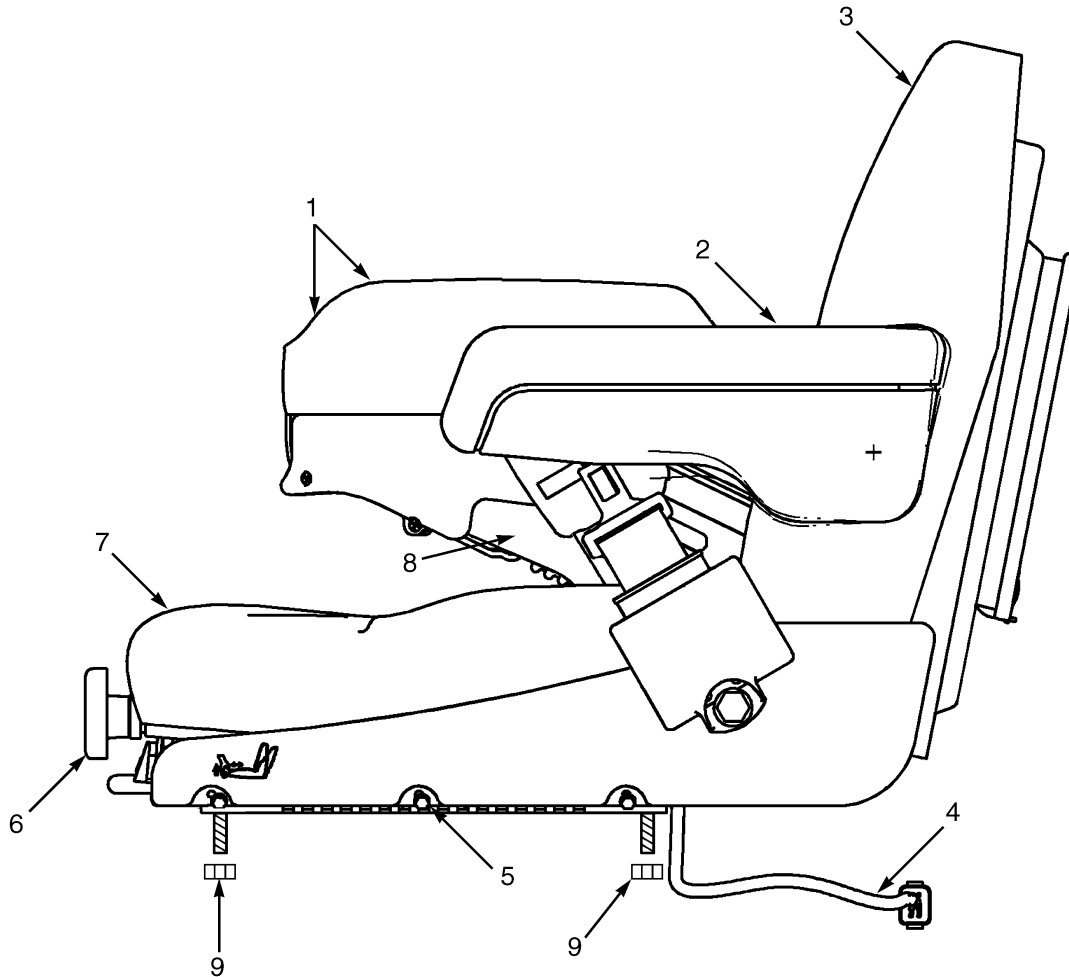

BP120109

SEMI SUSPENSION SEAT WITH AND WITHOUT ELECTRONIC CONTROLS

KEY:**A: Without Arm Controls****B: With Arm Controls**

ITEM	PART NO.	DESCRIPTION	QTY	
			A	B
	1593411	Seat Assembly (Vinyl).....	1	..
	1593412	Seat Assembly (Cloth).....	1	..
	1593415	Seat Assembly (Vinyl).....	..	1
	1593416	Seat Assembly (Cloth).....	..	1
1	1453882	Armrest.....	1	..
1	1453883	Armrest.....	1	..
2	1563210	Foam Cap (Electronic Control Arm)	1
2	1563211	Knobs (Electronic Control Arm).....	..	1
3	1382111	Back Cushion (Vinyl).....	1	1
3	1382113	Back Cushion (Cloth)	1	1
4	2075429	Wire Harness	1	..
4	2075428	Wire Harness	1
5	1459173	Slide Kit	1	..
5	1563895	Slide Kit	1
6	1563227	Weight Adjust Knob.....	1	1
7	1382112	Seat Cushion (Vinyl).....	1	1
7	1382114	Seat Cushion (Cloth).....	1	1
8	1598504	Seat Belt Kit.....	1	1
9	191941	Nut	4	4
	a 1362049	Shock Absorber Kit.....	1	1
	a 1563215	Sensor (Operator Presence).....	1	1

FOOTNOTES:**a** Not Illustrated

FULL SUSPENSION SEAT (Figure 1-9) WITH AND WITHOUT ELECTRONIC CONTROLS

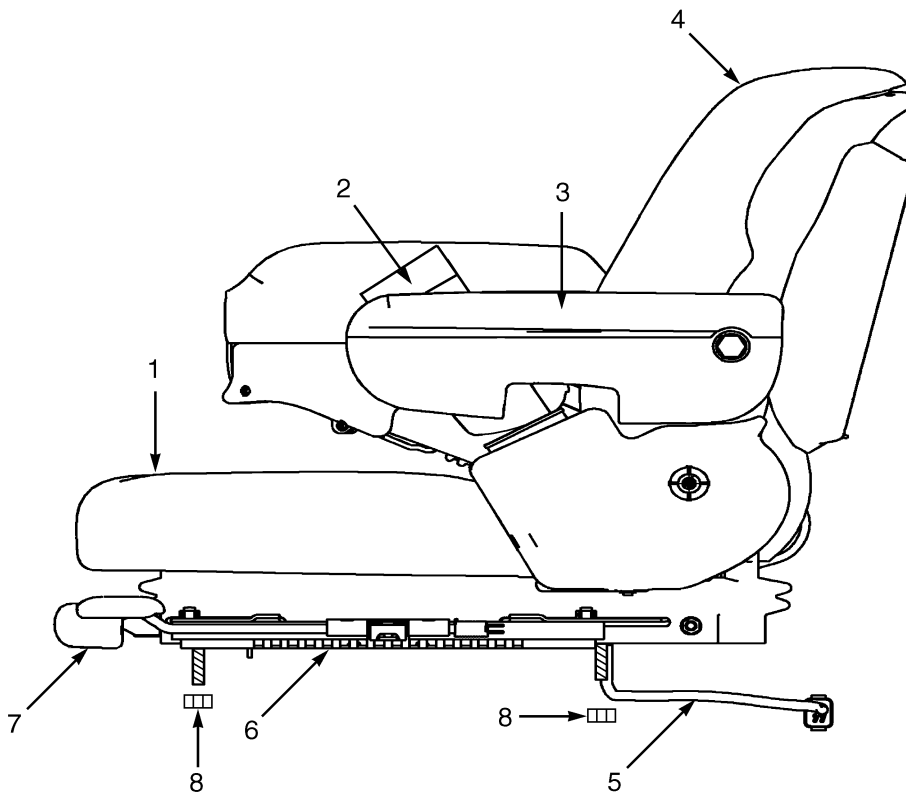

BP120111

FULL SUSPENSION SEAT WITH AND WITHOUT ELECTRONIC CONTROLS

KEY:**A: Full Suspension (Vinyl)****B: Full Suspension (Cloth)****C: Full Suspension (Vinyl with Electronic Control Arm)****D: Full Suspension (Cloth with Electronic Control Arm)**

ITEM	PART NO.	DESCRIPTION	QTY			
			A	B	C	D
	1593413	Full Suspension Seat (Vinyl).....	1
	1593414	Full Suspension Seat (Cloth).....	..	1
	1593417	Full Suspension Seat (Vinyl).....	1	..
	1593418	Full Suspension Seat (Cloth).....	1
1	1563207	Seat Cushion.....	1	..	1	..
1	1566453	Seat Cushion.....	..	1	..	1
2	1598504	Seat Belt Kit.....	1	1	1	1
3	1563230	Arm Cushion (LH)	1	1	1	1
3	1563231	Arm Cushion (RH).....	1	1
4	1470152	Back Cushion (Vinyl)	1	..	1	..
4	1470153	Back Cushion (Cloth)	1	..	1
5	2075429	Wire Harness	1	1
5	2075428	Wire Harness	1	1
6	1470161	Slide Kit.....	1	1	1	1
7	1470163	Weight Adjuster Kit.....	1	1	1	1
8	191941	Nut.....	4	4	4	4
	a 1483828	Shock Kit.....	1	1	1	1
	a 1563210	Foam Cap (Electronic Control Arm).....	1	1
	a 1563211	Knobs (Electronic Control Arm)	1	1
	a 1563208	Sensor	1	1	1	1

FOOTNOTES:**a** Not Illustrated

FULL SUSPENSION SWIVEL SEAT (Figure 1-10) WITH AND WITHOUT ELECTRONIC CONTROLS

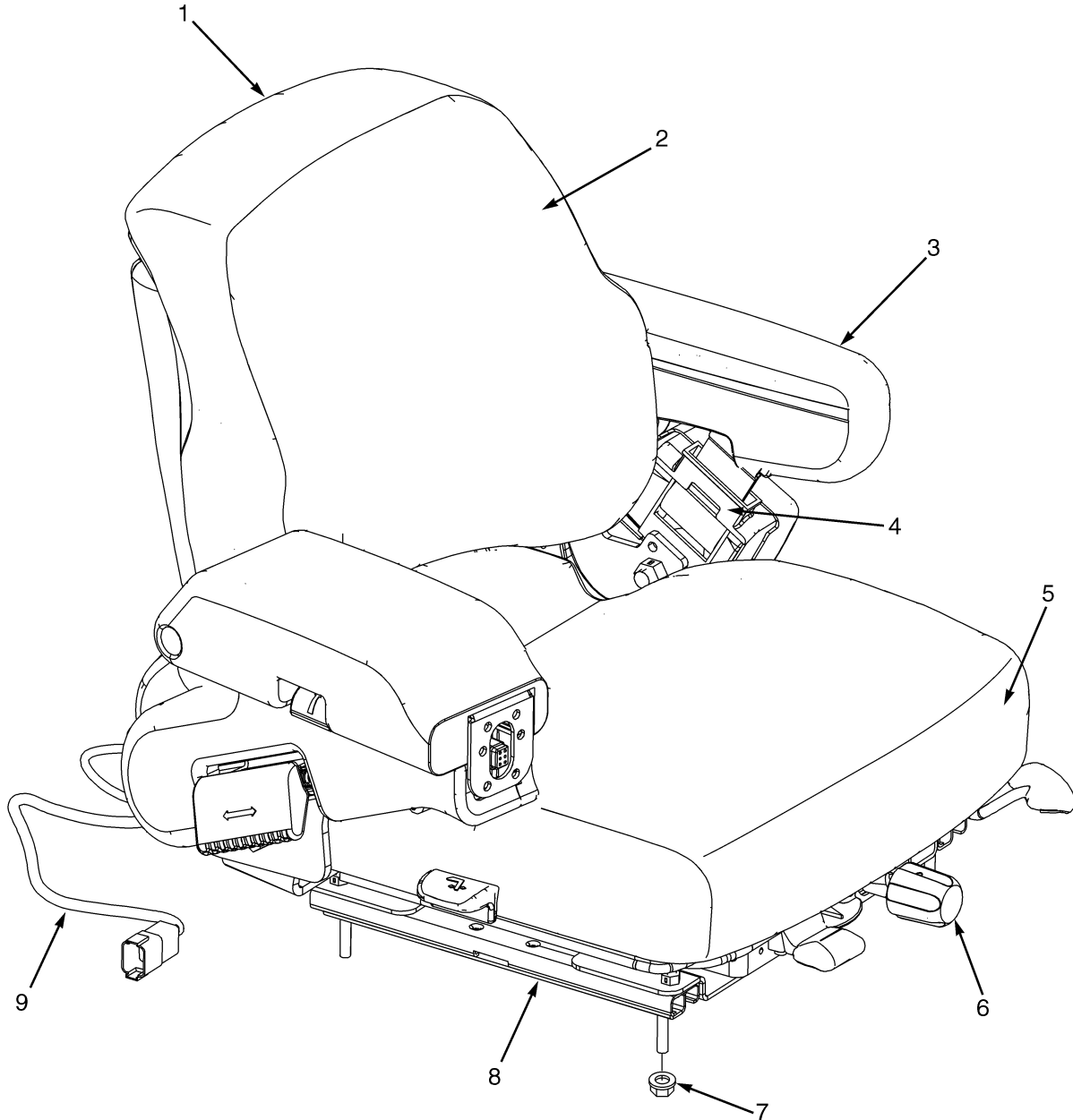

BP120119

Thank you so much for reading.
Please click the “Buy Now!”
button below to download the
complete manual.



After you pay.

You can download the most
perfect and complete manual in
the world immediately.

Our support email:

ebooklibonline@outlook.com