

PARTS MANUAL

HYSTER

**H3.50-5.50XM, H4.00XM-6,
H4.00XMS-6
(L005)**

CUSTOMER EDITION

HYSTER

SECTIONS

1	FRAME
2	ENGINES
3	FUEL SYSTEM
4	ELECTRICAL SYSTEM
5	TRANSMISSION
6	STEERING SYSTEM
7	BRAKE SYSTEM
8	HYDRAULIC SYSTEM
9	MAST-TWO STAGE LIMITED FREE-LIFT
10	MAST-TWO STAGE FULL FREE-LIFT
11	MAST-THREE STAGE FULL FREE-LIFT
12	OPTIONS
13	NUMERICAL INDEX

TABLE OF CONTENTS

DESCRIPTION	PAGE
A	
AIR FILTER	
LPG AND DIESEL TIER II	3-40
AIR INTAKE AND FILTER SYSTEM	
DIESEL TIER II	3-46
LPG	3-42
ALTERNATOR AND BATTERY	
LPG	4-22
ALTERNATOR AND MOUNTING	
DIESEL	4-28
ASSEMBLED ENGINE	
DIESEL TIER II	2-22
LPG WITH POWER SHIFT TRANSMISSION	
PENDING PER ECN 93375-07⇒	2-54
AUDIBLE ALARM	12-66
AUXILIARY TUBE EXTENSION KIT	
TWO AND THREE STAGE FULL FREE-LIFT	12-42
TWO STAGE LIMITED FREE-LIFT	12-40
B	
BAFFLE AND ATTACHING PARTS	2-12
BRAKE ASSEMBLY	
H3.50XM, H4.00XM, H4.00XMS	7-8
H4.50XM, H5.00XM, H5.50XM	7-12
BRAKE RELAY ASSEMBLY	7-18
BRAKE SYSTEM	
HYDROSTATIC TRANSMISSION	7-6
POWERSHIFT	7-2
C	
CAB	
DOOR ASSEMBLY	12-30
CAB ATTACHING PARTS	
1 OF 6	12-14
2 OF 6	12-16
3 OF 6	12-18
4 OF 6	12-20
5 OF 6	12-22
6 OF 6	12-26
CAMSHAFT AND OIL PAN	
LPG	2-66
CARBURETOR	
LPG	
WITH HYDROSTATIC TRANSMISSION	3-22
CARRIAGE	
THREE STAGE FULL FREE-LIFT	11-24
TWO STAGE FULL FREE-LIFT	10-18
TWO STAGE LIMITED FREE-LIFT	9-18
CLUTCH PACKS	
T092 - T096 POWERSHIFT	
⇒D/B 10/2004	5-16

TABLE OF CONTENTS (Continued)

DESCRIPTION	PAGE
C (continued)	
T118 - T121 POWERSHIFT TWO SPEED D/B 10/2004⇒	5-20
T118 POWERSHIFT SINGLE SPEED D/B 10/2004⇒	5-18
COIL ASSEMBLY LPG WITH POWER SHIFT TRANSMISSION PENDING PER ECN 93375-07⇒	2-56
CONTROL VALVE HYDROSTATIC TRANSMISSION..... POWERSHIFT TRANSMISSION.....	5-44 5-22
COOLING SYSTEM DIESEL	2-8
LPG.....	2-4
COUNTERWEIGHT	1-30
CRANKSHAFT AND PISTONS DIESEL TIER II	2-30
CYLINDER BLOCK DIESEL TIER II	2-24
LPG.....	2-64
CYLINDER HEAD LPG.....	2-70
CYLINDER HEAD AND INDUCTION MANIFOLD DIESEL TIER II	2-26
D	
DIFFERENTIAL ASSEMBLY POWERSHIFT TRANSMISSION.....	5-30
DISTRIBUTOR LPG WITH HYDROSTATIC TRANSMISSION	4-36
DISTRIBUTOR ASSEMBLY LPG WITH POWER SHIFT TRANSMISSION PENDING PER ECN 93375-07⇒	4-38
DRIP SHIELD PENDING PER ECN 93375-07⇒	2-78
DRIVE AXLE HYDROSTATIC TRANSMISSION..... POWERSHIFT TRANSMISSION.....	5-36 5-32
DRIVE TIRE AND WHEEL SIT-SOLID TYRE.....	12-76
E	
ELECTRICAL SYSTEM COWL HYDROSTATIC TRANSMISSION	4-8
POWERSHIFT TRANSMISSION	4-4
DIESEL TIER II.....	4-24
ENGINE COMPARTMENT	

TABLE OF CONTENTS (Continued)

DESCRIPTION	PAGE
E (continued)	
LPG WITH POWER SHIFT TRANSMISSION	
PENDING PER ECN 93375-07⇒.....	4-20
LPG.....	4-18
THROTTLE-UP	
HYDROSTATIC TRANSMISSION.....	4-12
ENGINE AND ATTACHING PARTS	
LPG.....	2-50
ENGINE BELT DRIVE AND ALTERNATOR MOUNTING	
LPG WITH POWER SHIFT TRANSMISSION	
PENDING PER ECN 93375-07⇒.....	2-58
ENGINE FUEL SYSTEM	
LPG WITH POWER SHIFT TRANSMISSION	
PENDING PER ECN 93375-07⇒.....	3-28
ENGINE MOUNT	
DIESEL TIER II.....	2-20
ENGINE MOUNTING (LPG).....	2-60
EXHAUST	
LPG	
WITHOUT LOW EMISSIONS.....	2-80
EXHAUST (DIESEL TIER II).....	2-18
EXHAUST (LPG)	
THREE-WAY CATALYTIC CONVERTER	
WITH LOW EMISSIONS.....	2-82
EXHAUST GROUP	
LPG WITH POWER SHIFT TRANSMISSION	
PENDING PER ECN 93375-05⇒.....	2-84
EXHAUST MANIFOLD	
DIESEL TIER II.....	2-38
LPG.....	2-62
F	
FAN DRIVE ASSEMBLY.....	2-14
FENDER EXTENSIONS.....	12-68
FILTER AND LOCK-OFF VALVE	
LPG	
WITH HYDROSTATIC TRANSMISSION.....	3-24
FLOOR PLATES AND COVERS.....	1-22
FLYWHEEL AND TORQUE CONVERTER	
POWERSHIFT TRANSMISSION.....	5-28
FORKS	
POLISHED WITH FULL BOTTOM TAPER HOOK TYPE.....	1-40
STANDARD TAPER HOOK TYPE	
H3.50-4.00XM.....	1-38
H4.50-5.50XM.....	1-39
FREE-LIFT	
THREE STAGE FULL FREE-LIFT.....	11-12
FREE-LIFT CYLINDER	
THREE STAGE FULL FREE-LIFT.....	11-20
TWO STAGE FULL FREE-LIFT.....	10-14

TABLE OF CONTENTS (Continued)

DESCRIPTION	PAGE
F (continued)	
FUEL FILTER AND ATTACHING PARTS	
DIESEL TIER II	3-12
FUEL INJECTION PUMP	
DIESEL TIER II	
⇒S/N L005A01861B	2-44
WITH BLEED BACK SYSTEM	
S/N L005A01862B⇒	2-46
FUEL PUMP AND WATER SEPERATOR	
DIESEL TIER II	3-6
FUEL SENDER AND ATTACHING PARTS	
DIESEL TIER II	3-10
FUEL SUPPLY SYSTEM	
DIESEL TIER II	3-4
FUEL SYSTEM	
CLOSED LOOP	
LPG WITH HYDROSTATIC TRANSMISSION.....	3-18
LPG	
POWERSHIFT TRANSMISSION	3-26
OPEN LOOP	
LPG WITH HYDROSTATIC TRANSMISSION.....	3-14
FULL SUSPENSION SEAT	
PENDING PER ECN 74952⇒	1-12
SHEET 1 OF 2	
⇒PENDING PER ECN 74952	1-8
SHEET 2 OF 2	
⇒PENDING PER ECN 74952	1-10
G	
GENERAL TRUCK	1-2
GOVERNOR	
LPG	
WITH HYDROSTATIC TRANSMISSION.....	3-25
H	
HEADER HOSE	
THREE STAGE FULL FREE-LIFT	11-28
TWO STAGE FULL FREE-LIFT	10-22
TWO STAGE LIMITED FREE-LIFT.....	9-14
HEADLIGHTS, REAR LIGHTS, AND SIDE LIGHTS	
WITHOUT CAB.....	12-12
HEATER INSTALLATION	
DIESEL TIER II	12-36
LPG	
WITH POWERSHIFT TRANSMISSION.....	12-34
HOOD AND COVERS	1-14
HYDRAULIC CONTROL LINES	
FOUR FUNCTION	8-12
THREE FUNCTION	8-10
HYDRAULIC CONTROL VALVE	

TABLE OF CONTENTS (Continued)

DESCRIPTION	PAGE
H (continued)	
THREE AND FOUR FUNCTION	8-20
HYDRAULIC CONTROL VALVE ATTACHING PARTS	
FOUR FUNCTION	
WITH DETENTED LEVERS.....	8-16
THREE FUNCTION	
WITH AND WITHOUT DETENT LEVERS	8-14
WITH HYDROSTATIC TRANSMISSION	8-18
HYDRAULIC FILTER HOUSING	8-22
HYDRAULIC PUMP.....	8-26
HYDROSTATIC TRANSMISSION.....	5-42
HYDRAULIC PUMP MOUNTING	
HYDROSTATIC TRANSMISSION.....	5-40
HYDRAULIC SYSTEM	
WITH HYDROSTATIC TRANSMISSION	8-6
WITH POWERSHIFT TRANSMISSION	8-2
HYDRAULIC TEST PORT	8-24
I	
INNER AND FREE LIFT MAST	
TWO STAGE FULL FREE-LIFT	10-6
INNER MAST	
THREE STAGE FULL FREE-LIFT	11-6
TWO STAGE LIMITED FREE-LIFT.....	9-4
INSTRUMENT PANEL.....	4-15
INTERMEDIATE MAST	
THREE STAGE FULL FREE-LIFT	11-4
L	
LABELS.....	1-34
LIFTING EYE.....	12-64
LOAD BACKREST EXTENSIONS	1-36
LPG CONVERTER	
OPEN LOOP	
LPG WITH HYDROSTATIC TRANSMISSION.....	3-17
LPG REGULATOR AND LOCK-OFF	
WITH POWER SHIFT TRANSMISSION	
PENDING PER ECN 93375-07⇒	3-32
LPG TANK AND BRACKET	
SWING OUT	3-36
LPG TANK BRACKET	
FIXED	3-34
SWING OUT/DROP DOWN.....	3-38
M	
MAIN CYLINDER	
THREE STAGE FULL FREE-LIFT	11-16
TWO STAGE LIMITED FREE-LIFT.....	9-10
MAIN LIFT	
THREE STAGE FULL FREE-LIFT	11-8

TABLE OF CONTENTS (Continued)

DESCRIPTION	PAGE
M (continued)	
TWO STAGE LIMITED FREE-LIFT	9-6
MAIN LIFT CYLINDER	
TWO STAGE FULL FREE-LIFT	10-10
MANIFOLD VALVE	
POWERSHIFT TRANSMISSION	5-24
MAST INSTALLATION	8-28
MASTER CYLINDER AND BOOSTER ASSEMBLY	7-14
MIRROR	
WITHOUT CAB	12-4
MONOTROL PEDAL	3-72
MONOTROL PEDAL AND BRACKET ASSEMBLY	
PENDING PER ECN 93427⇒	3-70
⇒PENDING PER ECN 93427	3-68
N	
NON-SUSPENSION SEAT	
PENDING PER ECN 74952⇒	1-6
⇒PENDING PER ECN 74952	1-4
O	
OIL COOLER	
DIESEL TIER II	2-41
OIL FILTER	
DIESEL TIER II	2-39
OIL PAN AND PUMP	
DIESEL TIER II	2-32
OIL PUMP	
LPG	2-76
OPERATOR COMPARTMENT	1-18
OUTER MAST	
THREE STAGE FULL FREE-LIFT	11-2
TWO STAGE LIMITED FREE-LIFT	9-2
OUTER MAST AND MAIN LIFT	
TWO STAGE FULL FREE-LIFT	10-2
OVERHEAD GUARD	1-20
P	
PARK BRAKE	7-16
R	
REAR DRIVING LIGHT	
WITHOUT CAB	12-10
ROTARY EXHAUSTER	
DIESEL TIER II	2-48
ROTATING BEACON	
WITHOUT CAB	12-8

TABLE OF CONTENTS (Continued)

DESCRIPTION	PAGE
S	
SCREEN	
REAR.....	1-32
SHIFT LEVER.....	6-6
SIDE-SHIFT CARRIAGE	
TWO AND THREE STAGE FULL FREE-LIFT	
H3.50XM, H4.00XM, H4.00XMS.....	12-48
H4.00XM, H4.50XM, H5.00XM, H5.50XM.....	12-50
TWO STAGE LIMITED FREE-LIFT	
H3.50XM, H4.00XM, H4.00XMS.....	12-44
H4.00XM, H4.50XM, H5.00XM, H5.50XM.....	12-46
SIDE-SHIFT FRAME	
1219 MM TWO STAGE LIMITED FREE-LIFT	
H3.50XM, H4.00XM, H4.00XMS.....	12-52
1219 MM, TWO AND THREE STAGE FULL FREE-LIFT	
H3.50XM, H4.00XM, H4.00XMS.....	12-58
1372 AND 1524 MM TWO AND THREE STAGE FULL FREE-LIFT	
H4.00XM, H4.50XM, H5.00XM, H5.50XM.....	12-62
1372 MM AND 1524 MM, TWO STAGE LIMITED FREE-LIFT	
H4.00XM, H4.50XM, H5.00XM, H5.50XM.....	12-56
1524 MM, TWO AND THREE STAGE FULL FREE-LIFT	
H3.50XM, H4.00XM, H4.00XMS.....	12-60
1524 MM, TWO STAGE LIMITED FREE-LIFT	
H3.50XM, H4.00XM, H4.00XMS.....	12-54
SIT TIRE AND WHEEL	
STEER.....	6-18
SOUND REDUCTION.....	1-24
SPOT LIGHT	
WITHOUT CAB.....	12-6
STARTER MOTOR	
DIESEL TIER II.....	4-34
LPG.....	4-32
STEER AXLE.....	6-8
STEER TIRES AND WHEELS.....	6-16
STEERING COLUMN.....	6-4
STEERING CYLINDER.....	6-12
STEERING PUMP.....	6-14
STEERING SYSTEM.....	6-2
T	
THROTTLE ARM ASSEMBLY.....	3-66
THROTTLE BODY AND LPG MIXER	
LPG WITH POWER SHIFT TRANSMISSION	
PENDING PER ECN 93375-07⇒.....	3-30
THROTTLE LINKAGE	
DIESEL	
POWERSHIFT TRANSMISSION.....	3-58
DIESEL FORWARD AND REVERSE LEVER	
WITH HYDROSTATIC TRANSMISSION.....	3-64
DIESEL MONOTROL	
WITH HYDROSTATIC TRANSMISSION.....	3-60
LPG	

TABLE OF CONTENTS (Continued)

DESCRIPTION	PAGE
T (continued)	
POWERSHIFT TRANSMISSION	3-50
LPG MONOTROL	
WITH HYDROSTATIC TRANSMISSION	3-54
WITH HYDROSTATIC TRANSMISSION	
LPG FORWARD AND REVERSE LEVER	3-52
TILT CYLINDER	8-30
TIMING GEAR	
DIESEL TIER II	2-36
TIRE AND WHEEL	
DUAL DRIVE WHEEL	12-72
RADIAL	12-70
SINGLE DRIVE WHEEL	
PNEUMATIC	12-74
TRANSMISSION	
T086 - T089 POWERSHIFT	
SHEET 1 OF 2	
⇒D/B 10/2004	5-2
SHEET 2 OF 2	
⇒D/B 10/2004	5-6
T118 - T121 POWERSHIFT	
SHEET 1 OF 2	
D/B 10/2004⇒	5-10
SHEET 2 OF 2	
D/B 10/2004⇒	5-12
TRANSMISSION CONTROLLER	
HYDROSTATIC	4-14
TRANSMISSION LINES	
POWERSHIFT TRANSMISSION	5-26
TRANSMISSION MOUNTING	
POWERSHIFT TRANSMISSION	5-31
U	
UNDERCARRIAGE PAN	
PENDING PER ECN 92950⇒	1-28
⇒PENDING PER ECN 92950	1-26
V	
VALVE	
HIGH AND LOW	
POWERSHIFT TRANSMISSION	5-25
VALVE COVER AND INLET MANIFOLD	
LPG	2-72
WITH POWER SHIFT TRNSMISSION	
PENDING PER ECN 93375-07⇒	2-74
VALVE COVER AND ROCKER ARM SHAFT	
DIESEL TIER II	2-28

TABLE OF CONTENTS (Continued)

DESCRIPTION	PAGE
W	
WATER PUMP AND OUTLET	
DIESEL TIER II	2-34
WATER SEPARATOR	
DIESEL TIER II	3-8
WIRE HARNESS	
AUXILIARY LIGHTS	
WORKLIGHTS	12-39
BRAKE PRESSURE SWITCH	
Pending Per ECN 93150⇒	4-79
⇒Pending Per ECN 93150	4-78
DIAGNOSTIC.....	4-31
DIESEL ENGINE	
S/N L005A02652C⇒	4-42
⇒S/N L005A02652C	4-40
ENGINE, LPG, GM V6, 4.3L	
SHEET 1 OF 2	4-44
SHEET 2 OF 2	4-46
HYDROSTATIC THROTTLE-UP	
FOUR FUNCTION.....	4-74
THREE FUNCTION.....	4-72
INTERFACE, LPG	
WITH POWER SHIFT TRANSMISSION	
PENDING PER ECN 93375-07⇒.....	4-56
LPG ENGINE WITH POWER SHIFT TRNSMISSION	
SHEET 1 OF 2	
PENDING PER ECN 93375-07⇒.....	4-49
SHEET 2 OF 2	
PENDING PER ECN 93375-07⇒.....	4-52
LPG REGULATOR	
LPG WITH POWER SHIFT TRANSMISSION	
PENDING PER ECN 93375-07⇒.....	4-54
LPG SWITCH.....	4-30
MODUAL	
HYDROSTATIC TRANSMISSION	4-64
POWERSHIFT TRANSMISSION CONTROL	
PENDING PER ECN 74952⇒	4-86
Pending Per ECN 93150⇒.....	4-82
⇒Pending Per ECN 93150.....	4-80
REVERSE ALARM	12-38
THROTTLE-UP SWITCH	
LPG HYDROSTATIC	4-76
WIRE HARNESS (MODULE)	
POWERSHIFT TRANSMISSION.....	4-58

SECTION 1
FRAME

DESCRIPTION	PAGE
COUNTERWEIGHT	1-30
FLOOR PLATES AND COVERS	1-22
FORKS	
POLISHED WITH FULL BOTTOM TAPER HOOK TYPE	1-40
STANDARD TAPER HOOK TYPE	
H3.50-4.00XM	1-38
H4.50-5.50XM	1-39
FULL SUSPENSION SEAT	
PENDING PER ECN 74952⇒	1-12
SHEET 1 OF 2	
⇒PENDING PER ECN 74952	1-8
SHEET 2 OF 2	
⇒PENDING PER ECN 74952	1-10
GENERAL TRUCK	1-2
HOOD AND COVERS	1-14
LABELS	1-34
LOAD BACKREST EXTENSIONS	1-36
NON-SUSPENSION SEAT	
PENDING PER ECN 74952⇒	1-6
⇒PENDING PER ECN 74952	1-4
OPERATOR COMPARTMENT	1-18
OVERHEAD GUARD.....	1-20
SCREEN	
REAR.....	1-32
SOUND REDUCTION	1-24
UNDERCARRIAGE PAN	
PENDING PER ECN 92950⇒	1-28
⇒PENDING PER ECN 92950	1-26

GENERAL TRUCK (Figure 1-1)

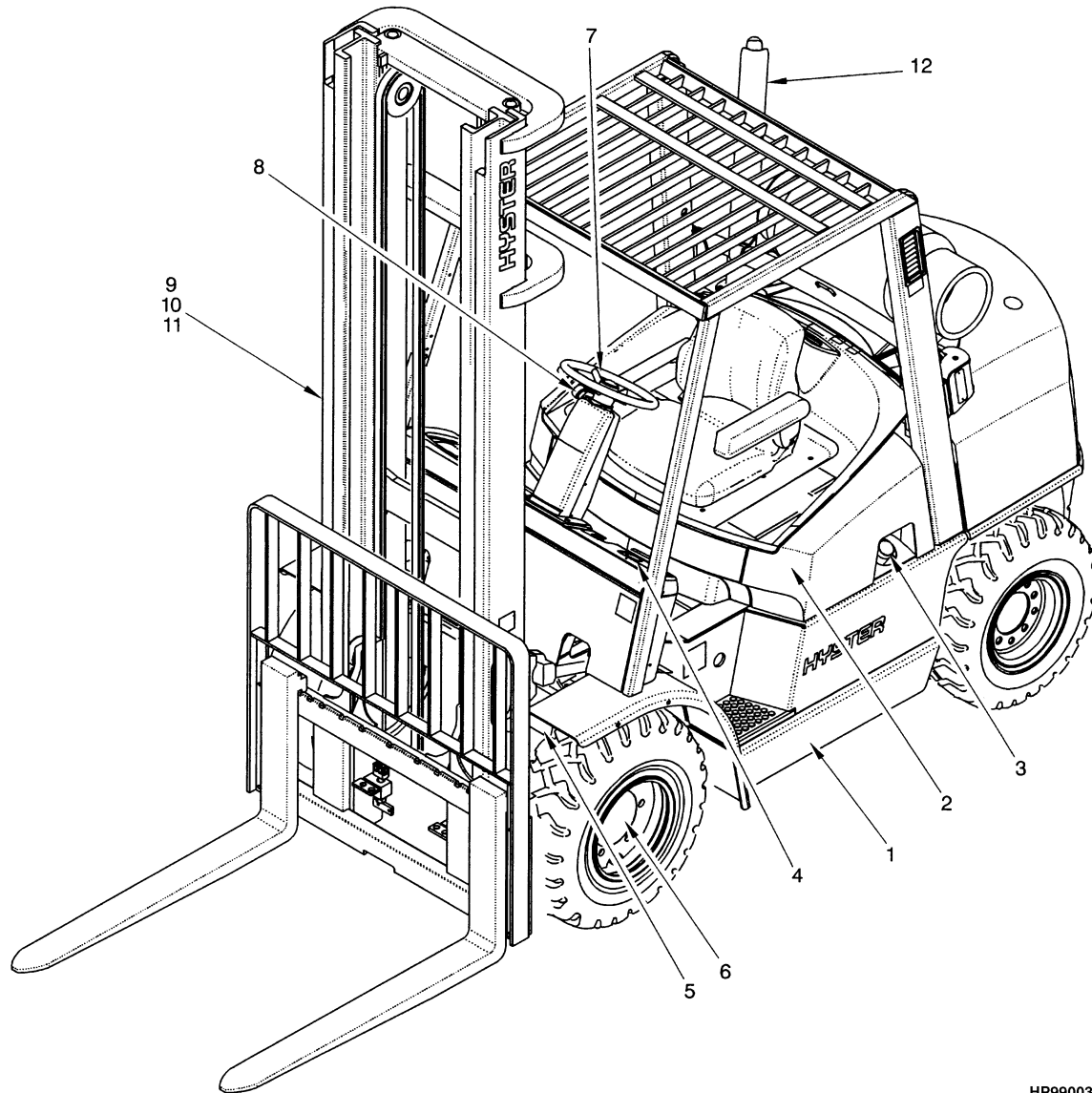

HP990030

ITEM	PART NO.	DESCRIPTION	QTY
1	Frame	1
2	Engine	1
3	Fuel System.....	1
4	Electrical System.....	1
5	Transmission.....	1
6	Brake System	1
7	Steering System	1
8	Hydraulic System.....	1
9	Mast-Two Stage Limited Free-Lift	1
10	Mast-Three Stage Full Free-Lift.....	1
11	Mast-Two Stage Full Free-Lift.....	1
12	Options	1

NON-SUSPENSION SEAT (Figure 1-2) (⇒PENDING PER ECN 74952)

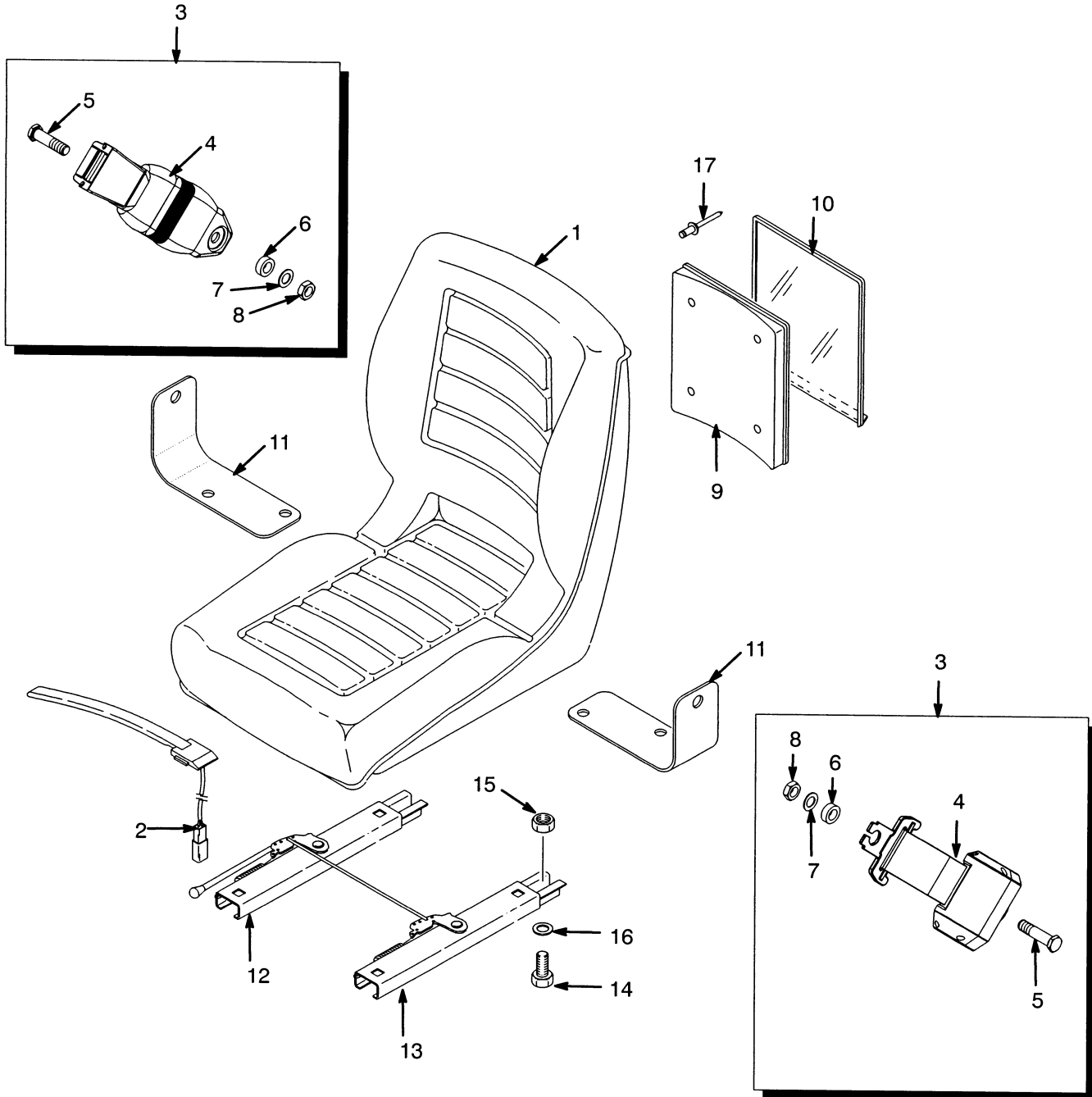

HP120254

NON-SUSPENSION SEAT
(⇒PENDING PER ECN 74952)

ITEM	PART NO.	DESCRIPTION	QTY
	1460231	Non-Suspension Seat.....	1
1	364911	Seat.....	1
2	2037311	Switch Assembly	1
3	1461081	Seat Belt Kit.....	1
4	Seat Belt	1
5	Screw	2
6	Washer.....	2
7	Washer.....	2
8	Nut	2
9	335988	Base	1
10	335991	Cover	1
11	1470175	Bracket	1
12	1470176	Seat Rail.....	1
13	1470177	Seat Rail.....	1
14	18498	Capscrew.....	4
15	145639	Nut	4
16	15175	Washer	4
17	Rivet.....	4

NON-SUSPENSION SEAT (Figure 1-3) (PENDING PER ECN 74952⇒)

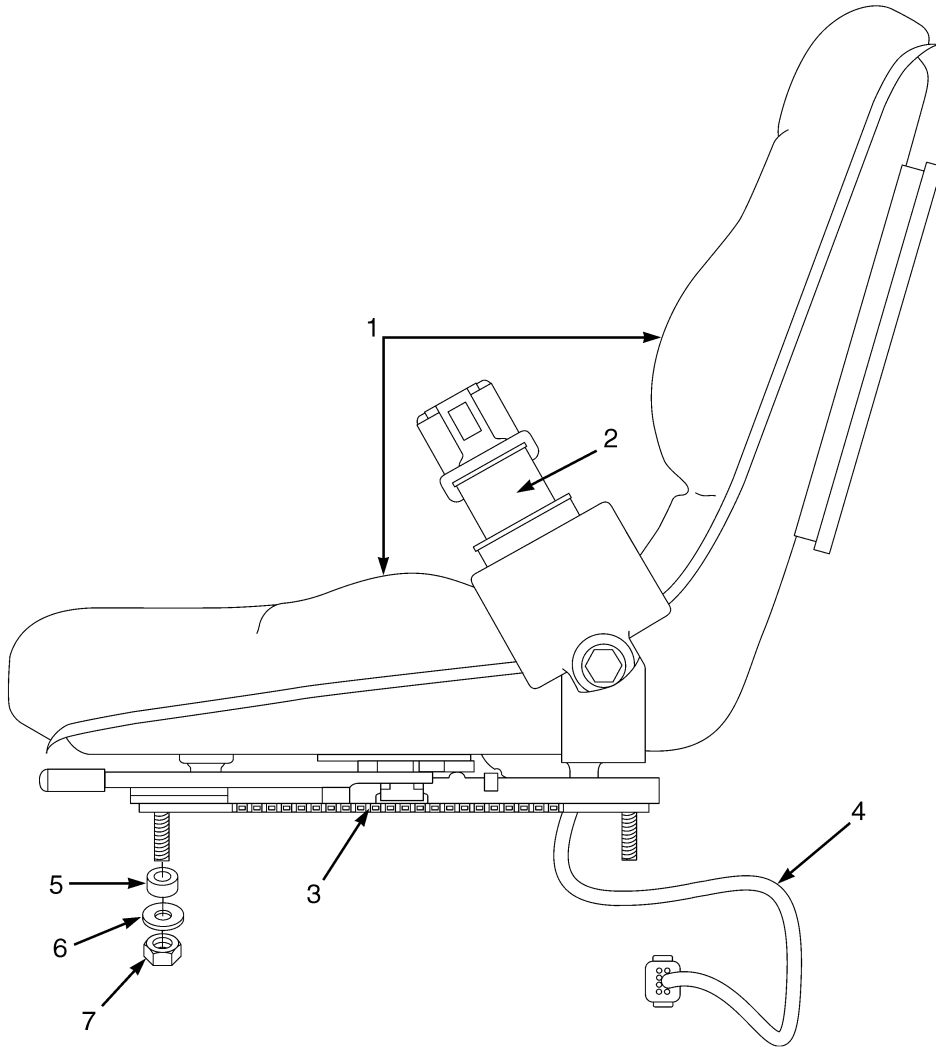

BP120183

**NON-SUSPENSION SEAT
(PENDING PER ECN 74952⇒)**

ITEM	PART NO.	DESCRIPTION	QTY
	1593409	Non-Suspension Seat (Vinyl).....	1
1	1563351	Cushions (Vinyl)	1
	a 1563215	Sensor (Operator Presence)	1
2	1598504	Seat Belt Kit.....	1
3	1459173	Slide Kit	1
4	2075429	Wire Harness	1
5	b 1484643	Spacer	4
6	15175	Washer	4
7	145639	Nut	4

FOOTNOTES:

- a** Not Illustrated
- b** Not used with this application

FULL SUSPENSION SEAT (Figure 1-4) SHEET 1 OF 2 (⇒PENDING PER ECN 74952)

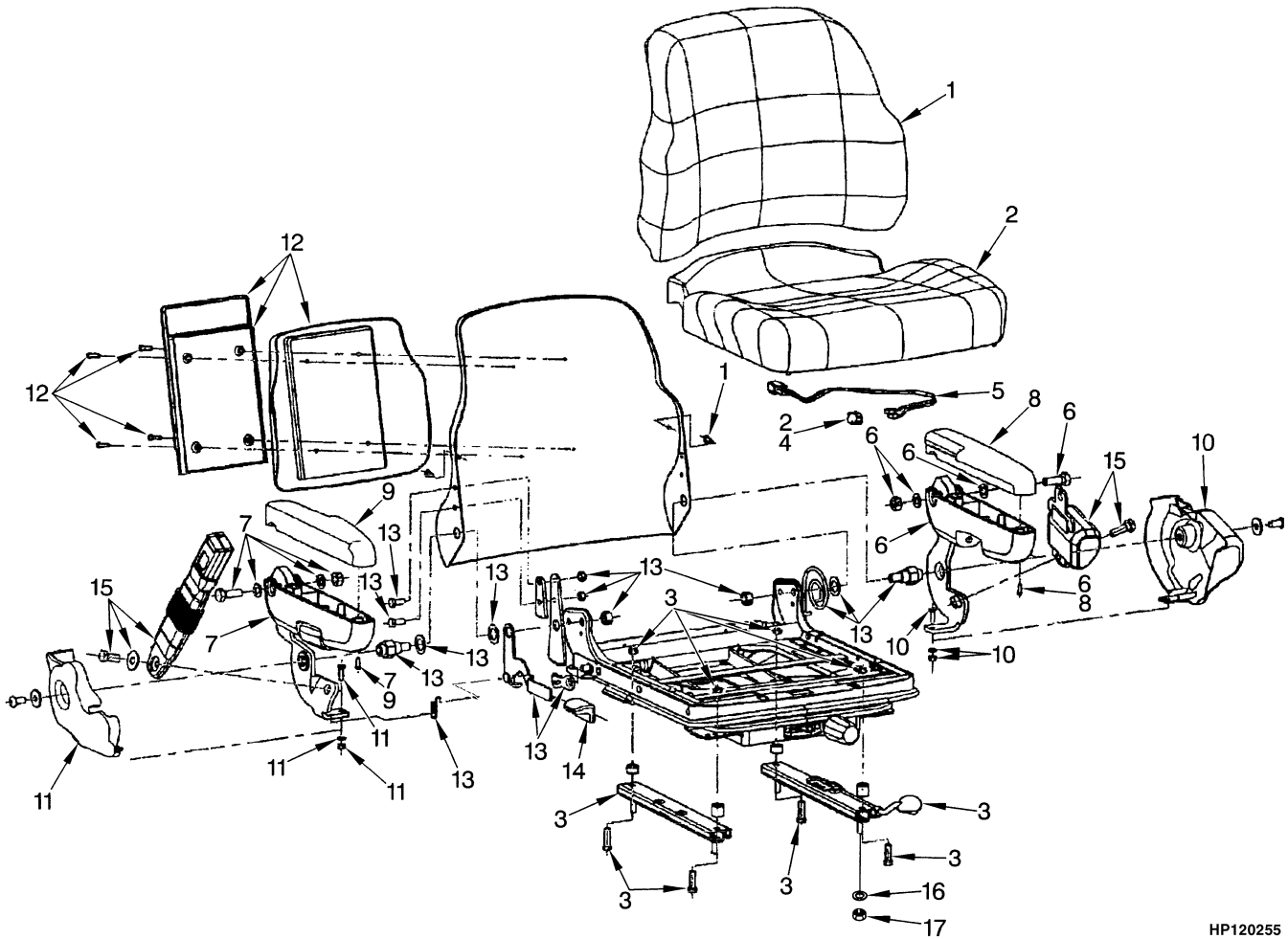

HP120255

**FULL SUSPENSION SEAT
SHEET 1 OF 2
(=>PENDING PER ECN 74952)**

ITEM	PART NO.	DESCRIPTION	QTY
	1466006	Full Suspension Seat (Vinyl Cover)	1
	1466007	Full Suspension Seat (Fabric Cover)	1
1	1467533	Back Cushion (Vinyl)	1
1	1467535	Back Cushion (Fabric)	1
2	1494076	Seat Cushion (Vinyl).....	1
2	1467536	Seat Cushion (Fabric)	1
3	1467513	Slider Kit	1
4	1467514	Switch (Seat)	1
5	1467515	Wire Harness	1
6	1467516	Armrest (LH) (LH).....	1
7	1467517	Armrest (RH) (RH)	1
8	1467518	Cap (LH).....	1
9	1467519	Cap (RH)	1
10	1467520	Cover (LH)	1
11	1467521	Cover (RH)	1
12	1467522	Holder Kit.....	1
13	1467530	Recliner Kit.....	1
14	1467531	Recliner Knob.....	1
15	1467532	Seat Belt Kit.....	1
16	15175	Washer	4
17	145639	Nut.....	4

FULL SUSPENSION SEAT (Figure 1-5) SHEET 2 OF 2 (⇒PENDING PER ECN 74952)

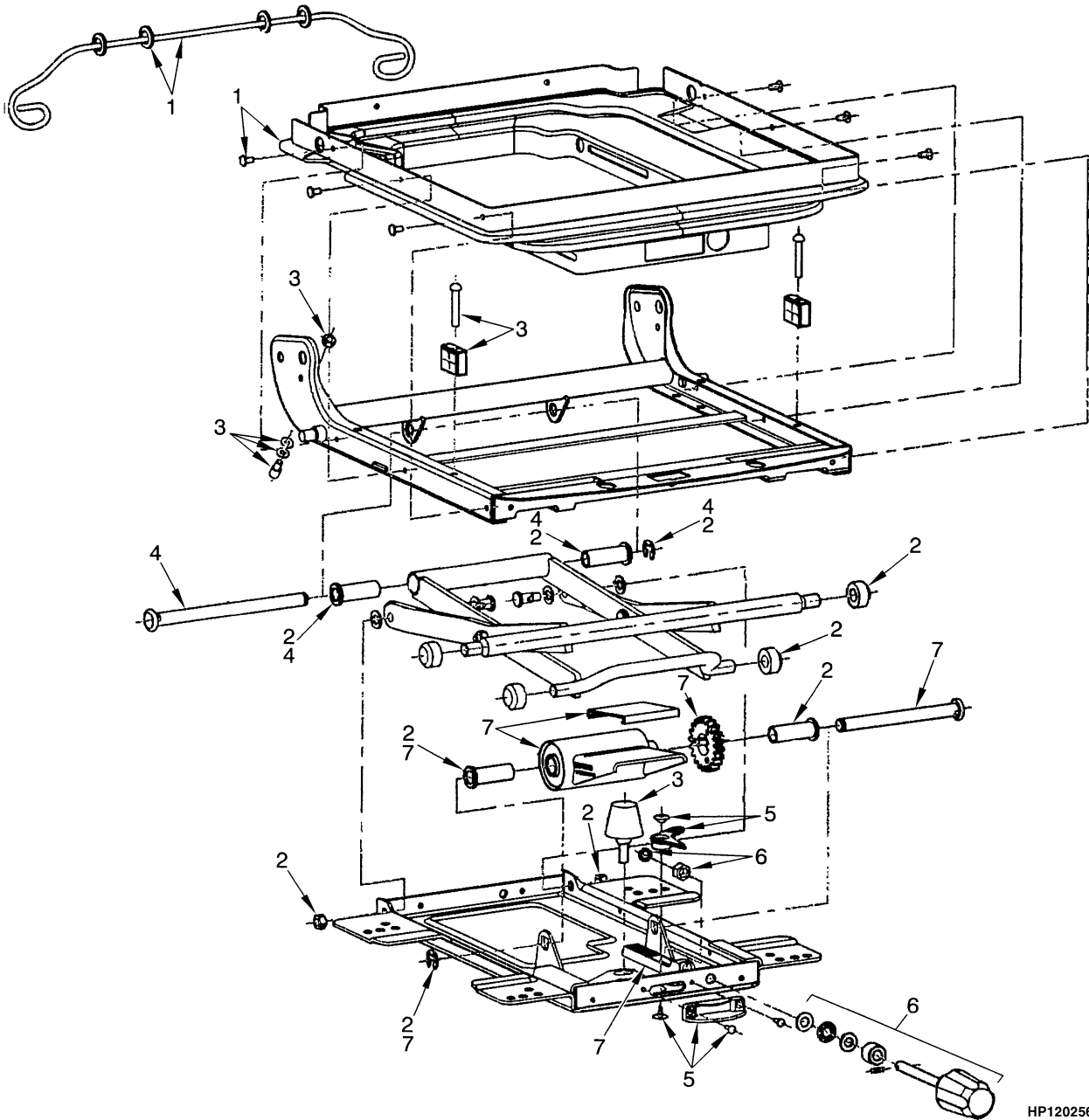

HP120256

**FULL SUSPENSION SEAT
SHEET 2 OF 2
(⇒PENDING PER ECN 74952)**

ITEM	PART NO.	DESCRIPTION	QTY
	1466006	Full Suspension Seat (Vinyl Cover)	1
	1466007	Full Suspension Seat (Fabric Cover)	1
1	1467523	Boot Kit.....	1
2	1467524	Roller and Bearing Kit	1
3	1467525	Bumper and Stop Kit	1
4	1467526	Bearing Shaft Kit	1
5	1467527	Weight Adjuster Indicator Kit	1
6	1467528	Knob Kit.....	1
7	1467529	Suspension Spring Kit.....	1

FULL SUSPENSION SEAT (Figure 1-6) (PENDING PER ECN 74952⇒)

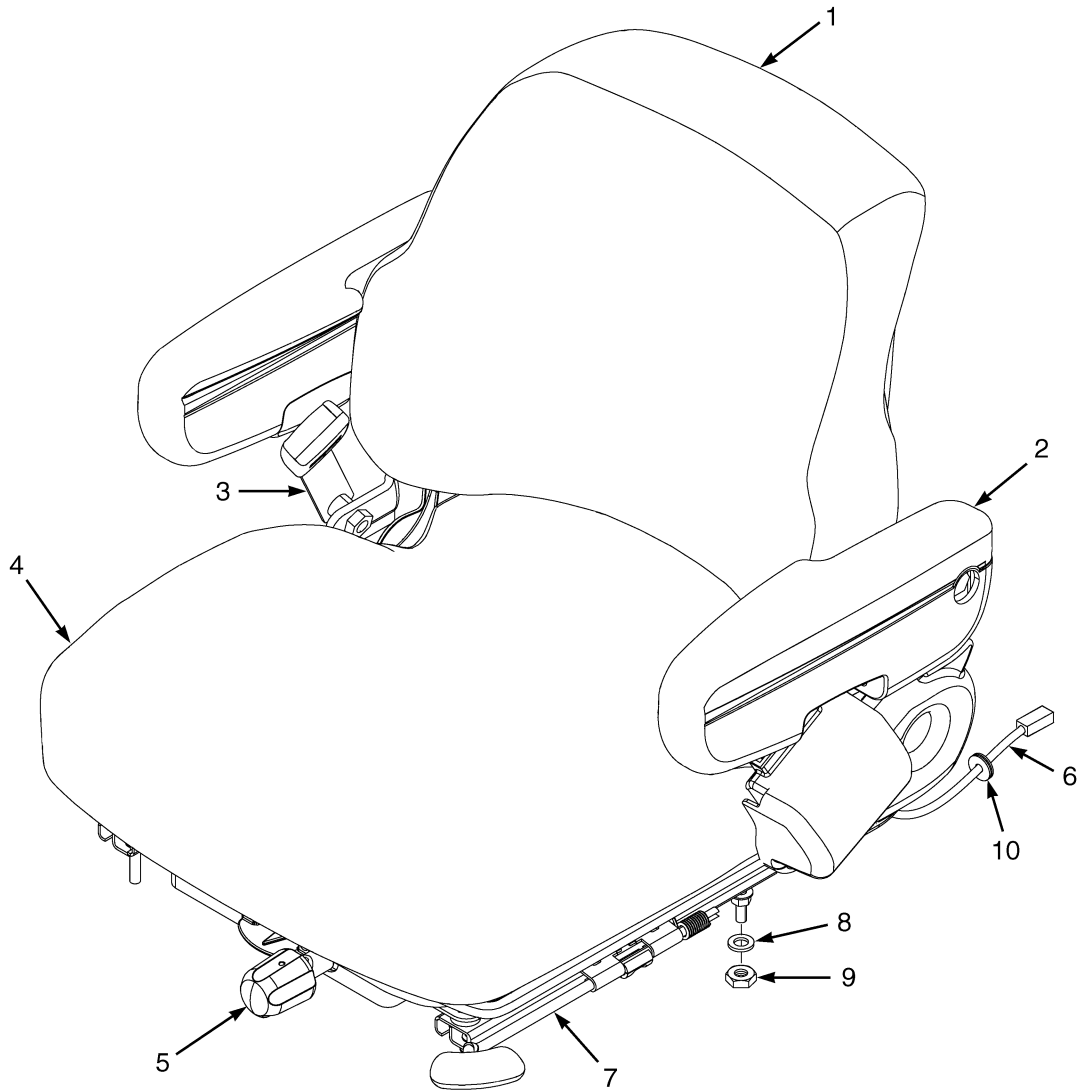

BP120178

**FULL SUSPENSION SEAT
(PENDING PER ECN 74952⇒)****KEY:****A: Vinyl****B: Cloth**

ITEM	PART NO.	DESCRIPTION	QTY	
			A	B
	1593413	Full Suspension Seat.....	1	..
	1593414	Full Suspension Seat.....	..	1
1	1470152	Back Cushion (Vinyl)	1	1
1	1470153	Back Cushion (Cloth)	1
2	1563230	Arm Cushion (LH)	1	1
2	1563231	Arm Cushion (RH).....	1	1
3	1598504	Seat Belt Kit.....	1	1
4	1563207	Seat Cushion (Vinyl).....	1	..
4	1566453	Seat Cushion (Cloth).....	..	1
	a 1563208	Sensor (Operator Presence)	1	1
5	1470163	Weight Adjuster Kit.....	1	1
6	2075429	Wire Harness	1	1
7	1470161	Slide Kit	1	1
8	b 1484643	Spacer
9	15175	Washer	4	4
10	145639	Nut	4	4
	a 1483828	Shock Kit.....	1	1

FOOTNOTES:**a** Not Illustrated**b** Not used with this application

HOOD AND COVERS (Figure 1-7)

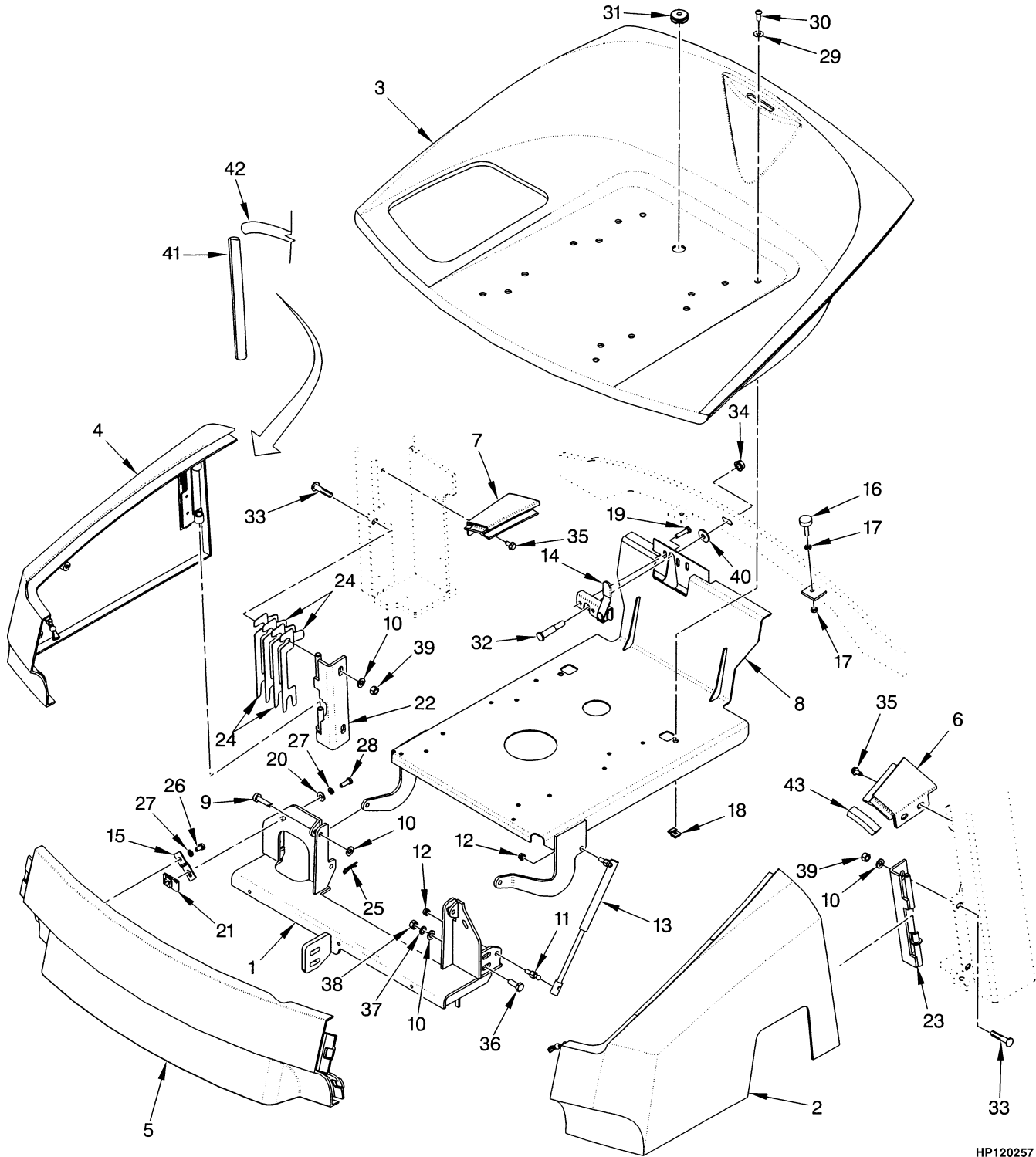

HP120257

HOOD AND COVERS

ITEM	PART NO.	DESCRIPTION	QTY
1	1491109	Crossmember	1
2	1397957	Panel (LH) (LPG)	1
2	1397958	Panel (LH) (Diesel)	1
3	a 1397960	Hood	1
3	b 1610832	Hood	1
4	1396626	Panel (RH)	1
5	1396625	Cover (Front).....	1
5	1392718	Latch.....	2
6	1397964	Corner (LH) (Without Cab)	1
6	1485280	Corner (LH) (With Cab)	1
7	1397963	Corner (RH) (Without Cab).....	1
7	1485281	Corner (RH) (With Cab).....	1
8	1488684	Seat Pan	1
9	2021207	Pin	2
10	320159	Washer	6
11	1350285	Stud (Ball).....	1
12	316835	Nut	4
13	1518858	Gas Spring Assembly	2
13	1513907	Ball Stud	2
14	2036143	Latch	1
15	2036866	Bracket.....	2
16	1347088	Stop Screw	2
17	15001	Nut	4
18	1385535	Nut	2
19	1529238	Capscrew.....	2
20	320158	Washer	4
21	1364259	Clip Nut.....	2
22	1470010	Hinge (RH).....	1
22	156133	Nut (Not illustrated).....	4
23	1470009	Hinge (LH)	1
24	2036142	Shim (1,194 mm)	4
25	1362714	Cotter Pin.....	2
26	287851	Capscrew.....	2
27	292681	Lockwasher.....	6
28	136749	Capscrew.....	2
29	375629	Washer	2
30	370599	Capscrew.....	2
31	a 1359587	Grommet.....	1
31	b 1561015	Grommet.....	1
32	1471866	Striker	1
33	220023	Bolt	4
34	264144	Nut	1
35	316678	Screw.....	4
36	136985	Capscrew.....	8
37	320157	Washer	2
38	316826	Nut	4
39	156133	Nut	8
40	2036863	Washer	1
41	1464909	Trim Seal.....	2

HOOD AND COVERS

ITEM	PART NO.	DESCRIPTION	QTY
42	1396658	Seal	2
43	1466416	Seal	2

FOOTNOTES:

- a ⇒ PENDING PER ECN 74952
- b PENDING PER ECN 74952 ⇒

OPERATOR COMPARTMENT (Figure 1-8)

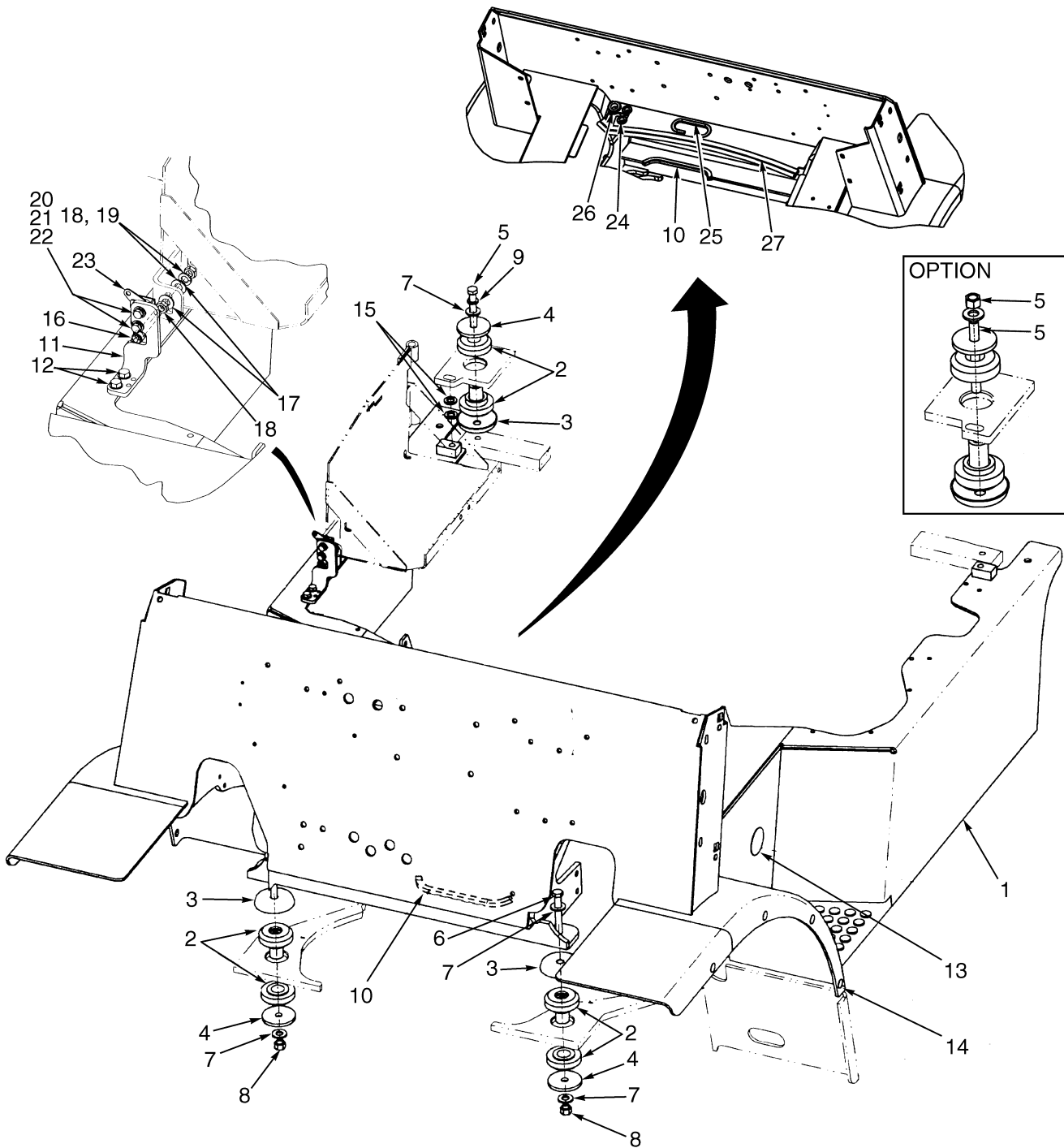

HP120735

OPERATOR COMPARTMENT

ITEM	PART NO.	DESCRIPTION	QTY
1	Operator Module.....	1
2	1378168	Mount.....	4
3	1378197	Cup	4
3	1351098	Cup (Optional)	4
4	300939	Washer	4
5	293657	Capscrew.....	2
5	2037998	Stud (Optional)	2
5	302402	Locknut (Optional)	2
6	293658	Capscrew.....	2
7	296423	Washer	6
8	302402	Locknut	2
9	292683	Lockwasher.....	2
10	1396024	Trim	1
11	1476761	Bracket.....	1
12	316678	Screw.....	2
13	1398009	Plug	2
14	1399760	Plug	8
15	296422	Washer	4
16	18762	Capscrew.....	1
17	15134	Washer	2
18	15086	Nut	2
19	15156	Lockwasher.....	1
20	18462	Capscrew.....	2
21	15154	Lockwasher.....	2
22	15127	Washer	2
23	1476422	Latch (Rotary).....	1
24	1367645	Grommet.....	2
25	2069375	Trim Seal.....	1
26	304195	Grommet.....	1
27	1520292	Trim Seal.....	1

OVERHEAD GUARD (Figure 1-9)

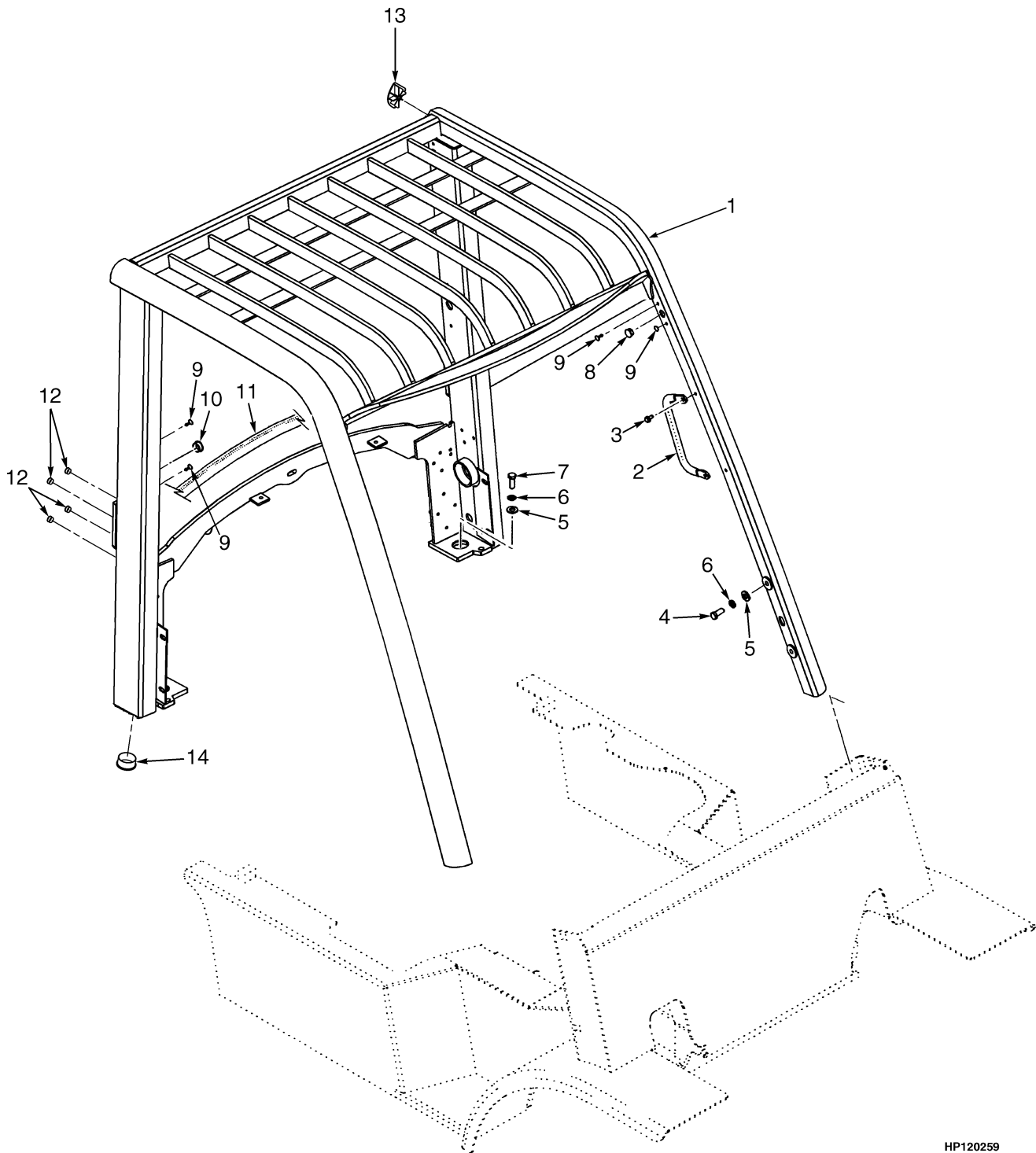

HP120259

OVERHEAD GUARD

ITEM	PART NO.	DESCRIPTION	QTY
1	1483504	Overhead Guard (Standard Height).....	1
1	1479585	Overhead Guard (Raised Height).....	1
2	2035800	Handle	1
3	316678	Screw.....	2
4	293644	Capscrew.....	4
5	296423	Washer	6
6	292683	Lockwasher.....	6
7	293646	Capscrew.....	2
8	1363917	Plug	6
9	1363916	Plug	14
10	1363918	Plug	4
11	1465740	Seal	1
12	1494888	Plug	2
13	1479633	Plug (Top Rail End Cap)	4
14	1356377	Plug	2

FLOOR PLATES AND COVERS (Figure 1-10)

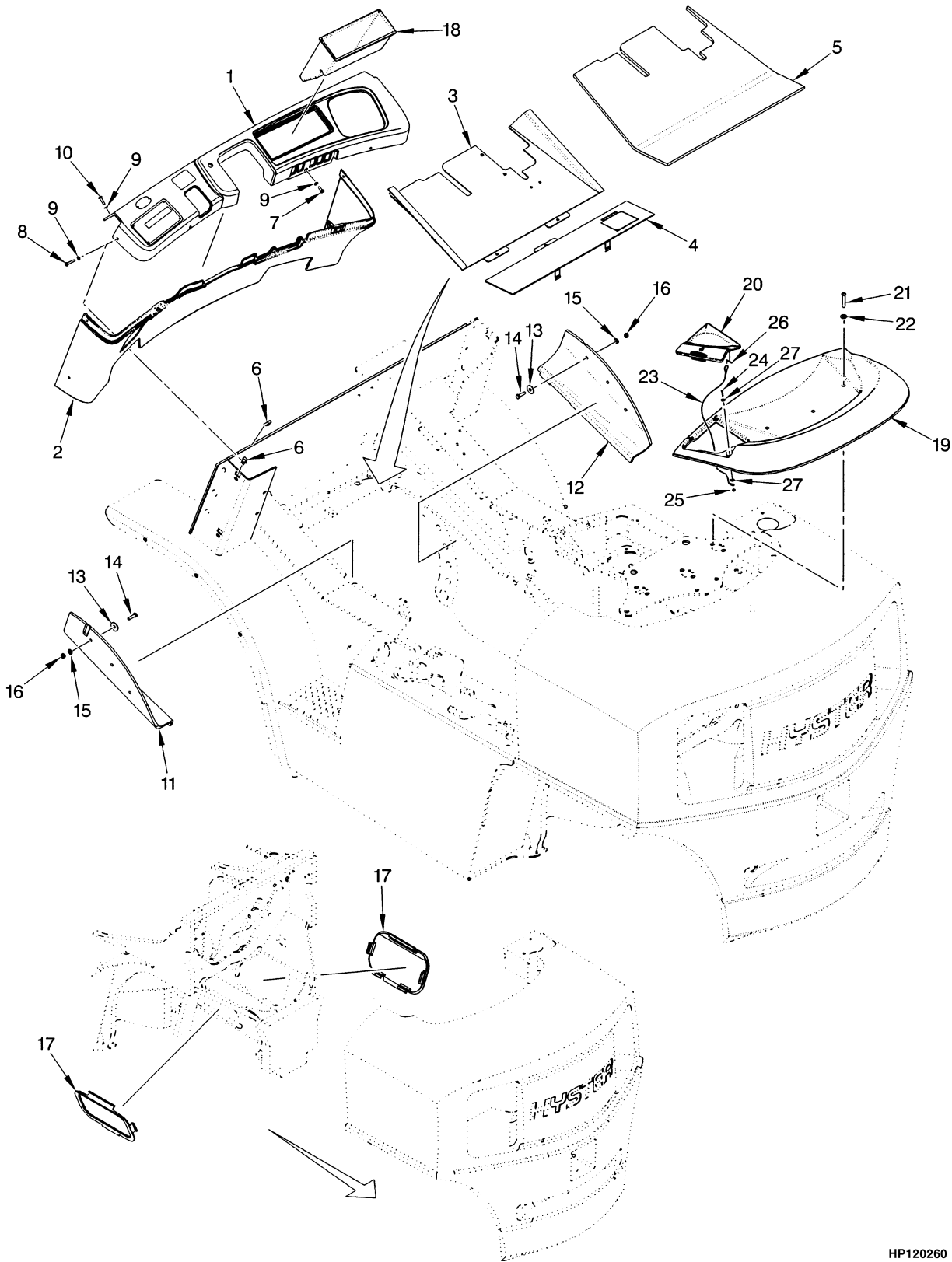

HP120260

FLOOR PLATES AND COVERS

ITEM	PART NO.	DESCRIPTION	QTY
1	1396147	Dash	1
2	1396148	Cowl Panel.....	1
3	2035798	Floorplate (Front).....	1
4	2035980	Floorplate.....	1
5	1396641	Floormat	1
6	1350215	Nut (Foldover).....	6
7	1525246	Screw.....	3
8	1525248	Screw.....	4
9	1399399	Washer	9
10	1525247	Screw.....	2
11	1399338	Flap (LH Cylinder)	1
12	1399337	Flap (RH Cylinder).....	1
13	1334790	Washer	6
14	176640	Capscrew.....	6
15	320157	Washer	6
16	302400	Locknut	6
17	2036875	Cover	2
18	1338286	Storage Compartment (For OHG Only).....	1
18	1400207	Cover (For Cabs Only).....	1
19	1385498	Cover (Radiator)	1
20	1396009	Radiator Cap Door (LPG)	1
20	1396012	Radiator Cap Door (Diesel)	1
21	1382107	Capscrew.....	3
22	375629	Washer	3
23	1400180	Lanyard.....	1
24	296510	Screw.....	1
25	302398	Nut	1
26	15212	Cotter Pin.....	1
27	320156	Washer	2

SOUND REDUCTION (Figure 1-11)

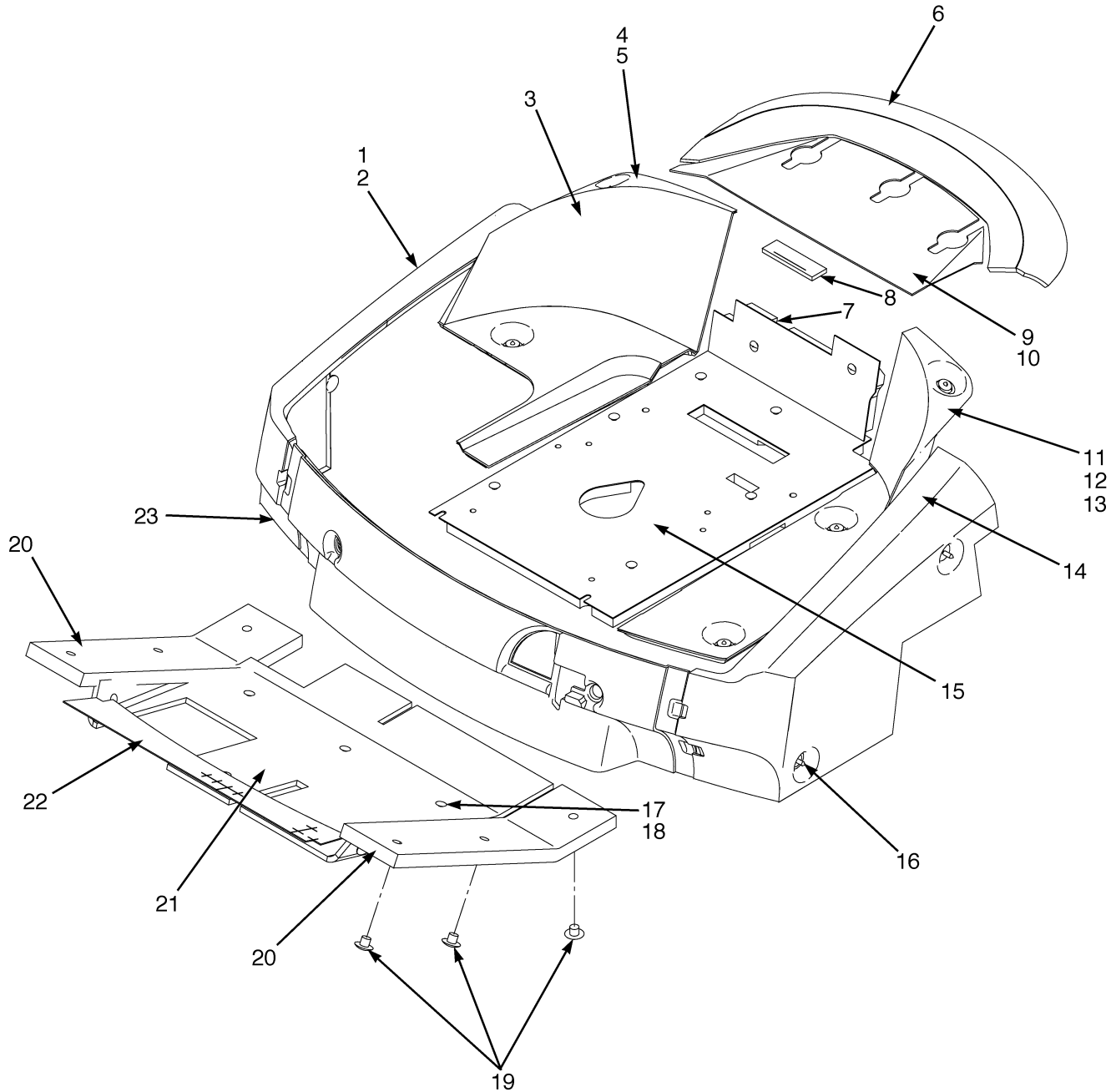

BP120079

Thank you so much for reading.
Please click the “Buy Now!”
button below to download the
complete manual.



After you pay.

You can download the most
perfect and complete manual in
the world immediately.

Our support email:

ebooklibonline@outlook.com