

# **PARTS MANUAL**

---

**H2.0FT-H3.5FT  
(L177)**

CUSTOMER EDITION

---

***HYSTER***

**SECTIONS**

<b>1</b>	<b>FRAME</b>
<b>2</b>	<b>ENGINES</b>
<b>3</b>	<b>FUEL SYSTEM</b>
<b>4</b>	<b>ELECTRICAL SYSTEM</b>
<b>5</b>	<b>TRANSMISSION</b>
<b>6</b>	<b>DRIVE AXLE</b>
<b>7</b>	<b>STEERING SYSTEM</b>
<b>8</b>	<b>BRAKE SYSTEM</b>
<b>9</b>	<b>HYDRAULIC SYSTEM</b>
<b>10</b>	<b>MAST-TWO STAGE LIMITED FREE-LIFT</b>
<b>11</b>	<b>MAST-TWO STAGE FULL FREE-LIFT</b>
<b>12</b>	<b>MAST-THREE STAGE FULL FREE-LIFT</b>
<b>13</b>	<b>OPTIONS</b>
<b>14</b>	<b>NUMERICAL INDEX</b>

**TABLE OF CONTENTS**

DESCRIPTION	PAGE
<b>A</b>	
ACCUMULATOR AND ATTACHING PARTS.....	13-13
AIR CLEANER ASSEMBLY.....	3-2
AIR INTAKE AND FILTER SYSTEM	
GM 2.4L	
LPG.....	3-6
MAZDA 2.0L AND 2.2L	
LPG.....	3-4
YANMAR 2.6L AND 3.3L	
DIESEL.....	3-8
ALTERNATOR AND MOUNTING	
GM 2.4L	
LPG.....	2-50
YANMAR 2.6L AND 3.3L	
DIESEL.....	4-9
ASSEMBLED ENGINE	
GM 2.4L, LPG	
SHEET 1 OF 4.....	2-42
SHEET 2 OF 4.....	2-44
SHEET 3 OF 4.....	2-46
SHEET 4 OF 4.....	2-48
AUXILIARY ONE AND TWO	
MANUAL CONTROL VALVE	
THREE AND FOUR FUNCTION.....	9-22
AUXILIARY ONE SECTION	
ELECTRONIC CONTROL	
THREE AND FOUR FUNCTION.....	9-30
AUXILIARY TUBE EXTENSIONS	
TWO AND THREE STAGE FULL FREE-LIFT.....	13-30
TWO STAGE LIMITED FREE-LIFT.....	13-28
AUXILIARY TWO SECTION	
ELECTRONIC CONTROL	
FOUR FUNCTION.....	9-32
<b>B</b>	
BACK-UP ALARM.....	13-4
BATTERY CABLES	
GM 2.4L	
LPG.....	4-10
BRAKE ASSEMBLY	
DRY BRAKE.....	8-10
BRAKE COOLING SYSTEM	
SINGLE AND DUAL PEDAL	
WET BRAKE.....	8-14
BRAKE LINKAGE	
DUAL PEDAL	
DRY BRAKE.....	8-4
WET BRAKE.....	8-8
SINGLE PEDAL	
DRY BRAKE.....	8-2
WET BRAKE.....	8-6

## TABLE OF CONTENTS (Continued)

DESCRIPTION	PAGE
<b>C</b>	
CAB	
FRAME AND ATTACHING PARTS .....	1-28
INTERIOR PANELS .....	1-26
LH DOOR.....	1-20
RH DOOR AND HEATER ASSEMBLY .....	1-22
WINDOWS AND WINDOW WIPER SYSTEM .....	1-24
CAB AND ATTACHING PARTS .....	1-18
CAMSHAFT AND DRIVE GEAR	
YANMAR 2.6L AND 3.3L	
DIESEL.....	2-84
CAMSHAFT AND VALVES	
MAZDA 2.0L AND 2.2L	
LPG .....	2-30
CAMSHAFT, CYLINDER HEAD AND MANIFOLDS	
GM 2.4L	
LPG .....	2-58
CARRIAGE	
THREE STAGE FULL FREE-LIFT .....	12-28
TWO STAGE FULL FREE-LIFT .....	11-16
TWO STAGE LIMITED FREE-LIFT.....	10-14
CONTROL VALVE	
TRANSMISSION.....	5-34
CONTROL VALVE ASSEMBLY	
ELECTRONIC CONTROL	
THREE AND FOUR FUNCTION.....	9-26
MANUAL CONTROL	
THREE AND FOUR FUNCTION.....	9-18
COOLING MANIFOLD AND ATTACHING PARTS	
GM 2.4L	
LPG .....	2-51
COOLING SYSTEM	
GM 2.4L, LPG, SQUARE WAVE RADIATOR.....	2-52
MAZDA 2.0L AND 2.2L, LPG, SERPENTINE RADIATOR	
BASIC POWERSHIFT TRANSMISSION .....	2-8
MAZDA 2.0L AND 2.2L, LPG, SQUARE WAVE RADIATOR	
BASIC POWERSHIFT TRANSMISSION, WITH INTERNAL AIR OIL COOLER .....	2-10
ELECTRONIC CONTROL TRANSMISSION, WITH EXTERNAL AIR OIL COOLER .....	2-14
ELECTRONIC CONTROL TRANSMISSION, WITH INTERNAL AIR OIL COOLER .....	2-12
YANMAR 2.6L AND 3.3L, DIESEL, SQUARE WAVE RADIATOR	
WITH EXTERNAL AIR OIL COOLER.....	2-68
WITH INTERNAL AIR OIL COOLER .....	2-66
COUNTERWEIGHTS .....	1-14
COWL ELECTRICAL.....	4-16
COWL MOUNT.....	1-12
CRANKSHAFT AND PISTONS	
MAZDA 2.0L AND 2.2L	
LPG .....	2-32
YANMAR 2.6L AND 3.3L	
DIESEL.....	2-86
CRANKSHAFT, PISTONS AND OIL PAN	
GM 2.4L	

**TABLE OF CONTENTS (Continued)**

DESCRIPTION	PAGE
<b>C (continued)</b>	
LPG .....	2-62
CYLINDER BLOCK	
MAZDA 2.0L AND 2.2L	
LPG .....	2-34
YANMAR 2.6L AND 3.3L	
DIESEL.....	2-88
CYLINDER HEAD	
MAZDA 2.0L AND 2.2L	
LPG .....	2-28
YANMAR 2.6L AND 3.3L	
DIESEL.....	2-80
<b>D</b>	
DISTRIBUTOR	
MAZDA 2.0L AND 2.2L	
LPG .....	4-8
DRIVE AXLE AND ATTACHING PARTS	
WET BRAKE.....	6-2
DRIVE AXLE ASSEMBLY	
DRY BRAKE .....	6-4
DRIVE TIRE AND WHEEL	
PNEUMATIC RADIAL .....	6-10
SNAP-ON SOLID TIRE.....	6-12
SOLID PNEUMATIC	
SINGLE .....	6-7
WIDE TREAD.....	6-8
DUAL DRIVE WHEELS AND TIRES.....	6-14
<b>E</b>	
ELECTRICAL SYSTEM	
RH CHASSIS.....	4-2
ELECTRO HYDRAULIC POPPET VALVE	
ELECTRONIC CONTROL	
LIFT AND LOWER .....	9-38
EMISSIONS LINES	
MAZDA 2.0L AND 2.2L	
LPG .....	2-40
ENGINE ELECTRICAL COMPONENTS	
MAZDA 2.0L AND 2.2L	
LPG .....	4-4
ENGINE ELECTRICAL SYSTEM	
MAZDA 2.0L AND 2.2L	
LPG .....	4-6
YANMAR 2.6L AND 3.3L, DIESEL	
WITH OVERHEAD GUARD .....	4-12
ENGINE MOUNTING .....	2-4
EXHAUST MANIFOLD	
MAZDA 2.0L AND 2.2L	
LPG .....	2-18

## TABLE OF CONTENTS (Continued)

DESCRIPTION	PAGE
<b>E (continued)</b>	
EXHAUST SYSTEM	
GM 2.4L	
LPG .....	2-54
MAZDA 2.0L AND 2.2L	
LPG .....	2-16
YANMAR 2.6L AND 3.3L	
DIESEL.....	2-70
<b>F</b>	
FAN ASSEMBLY.....	2-6
FENDER EXTENSIONS.....	1-10
FIRE EXTINGUISHER.....	13-12
FLOORPLATES AND COVERS.....	1-6
FLYWHEEL AND HOUSING	
GM 2.4L	
LPG .....	2-56
MAZDA 2.0L AND 2.2L	
LPG .....	2-22
YANMAR 2.6L AND 3.3L	
DIESEL.....	2-78
FORKS.....	1-48
OPTIONAL.....	1-49
FORWARD CLUTCH	
SINGLE SPEED TRANSMISSION .....	5-18
FORWARD CLUTCH, HIGH	
DUAL SPEED TRANSMISSION.....	5-28
FREE-LIFT	
THREE STAGE FULL FREE-LIFT .....	12-16
TWO STAGE FULL FREE-LIFT .....	11-10
FREE-LIFT CYLINDER	
THREE STAGE FULL FREE-LIFT .....	12-20
TWO STAGE FULL FREE-LIFT .....	11-12
FUEL FILTER AND WATER SEPARATOR	
YANMAR 2.6L AND 3.3L	
DIESEL.....	3-26
FUEL INJECTION SYSTEM	
YANMAR 2.6L AND 3.3L	
DIESEL.....	3-24
FUEL SYSTEM	
GM 2.4L	
LPG .....	3-14
MAZDA 2.0L AND 2.2L	
LPG .....	3-10
YANMAR 2.6L AND 3.3L	
DIESEL.....	3-22

**TABLE OF CONTENTS (Continued)**

DESCRIPTION	PAGE
<b>G</b>	
GEAR HOUSING	
YANMAR 2.6L AND 3.3L	
DIESEL.....	2-74
GEAR PUMP.....	9-4
<b>H</b>	
HAND LEVERS	
FOUR FUNCTION	
WITH DETENTED LEVERS.....	9-14
WITHOUT DETENTED LEVERS.....	9-16
THREE FUNCTION	
WITH DETENTED LEVERS.....	9-10
WITHOUT DETENTED LEVERS.....	9-12
HEADER HOSES	
THREE STAGE FULL FREE-LIFT.....	12-24
TWO STAGE FULL FREE-LIFT.....	11-14
TWO STAGE LIMITED FREE-LIFT.....	10-12
HEATER HOSE ARRANGEMENT	
LPG AND DIESEL.....	13-10
HOOD ASSEMBLY.....	1-2
HYDRAULIC FILTER.....	9-6
HYDRAULIC HOSES	
LIFT, TILT, AND AUXILIARY.....	9-8
HYDRAULIC SUPPLY AND RETURN.....	9-2
<b>I</b>	
INNER MAST	
THREE STAGE FULL FREE-LIFT.....	12-6
TWO STAGE FULL FREE-LIFT.....	11-4
TWO STAGE LIMITED FREE-LIFT.....	10-4
INPUT CLUTCH, LOW	
DUAL SPEED TRANSMISSION.....	5-32
INSTRUMENT CLUSTER.....	4-19
INTAKE AND EXHAUST MANIFOLD	
YANMAR 2.6L AND 3.3L	
DIESEL.....	2-72
INTAKE MANIFOLD	
MAZDA 2.0L AND 2.2L	
LPG.....	2-20
INTEGRAL SIDE-SHIFT ASSEMBLY	
THREE STAGE FULL FREE-LIFT.....	13-22
TWO STAGE FULL FREE-LIFT.....	13-20
TWO STAGE LIMITED FREE-LIFT.....	13-16
INTEGRAL SIDE-SHIFT CYLINDER.....	13-26
INTEGRAL SIDE-SHIFT HYDRAULIC HOSES	
TWO AND THREE STAGE FULL FREE-LIFT.....	13-24
TWO STAGE LIMITED FREE-LIFT.....	13-18
INTERMEDIATE MAST	
THREE STAGE FULL FREE-LIFT.....	12-4

**TABLE OF CONTENTS (Continued)**

<b>DESCRIPTION</b>	<b>PAGE</b>
<b>J</b>	
JOYSTICK AND ELECTRONIC CONTROL LEVERS.....	4-20
<b>L</b>	
LABELS	
CONTROL LEVER.....	1-42
ELECTRONIC LEVER.....	1-44
EXTERIOR.....	1-38
INTERIOR.....	1-40
JOYSTICK.....	1-46
LIFTING EYE.....	13-2
LIGHTS	
BRAKE, TAIL, BACKUP, SIDE, TURN SIGNALS, WORK, STROBE WITH CAB.....	4-26
WITH OVERHEAD GUARD.....	4-24
LOAD BACK REST EXTENSION.....	1-50
LPG BRACKET ASSEMBLY	
EZCHANGE BRACKET.....	3-18
SWING OUT BRACKET.....	3-20
LPG REGULATOR	
GM 2.4L.....	3-16
LUBRICATION SYSTEM	
YANMAR 2.6L AND 3.3L DIESEL.....	2-92
<b>M</b>	
MAIN LIFT	
THREE STAGE FULL FREE-LIFT.....	12-8
TWO STAGE FULL FREE-LIFT.....	11-6
TWO STAGE LIMITED FREE-LIFT.....	10-6
MAIN LIFT CYLINDER	
LEFT HAND	
TWO STAGE FULL FREE-LIFT.....	11-9
RIGHT HAND	
TWO STAGE FULL FREE-LIFT.....	11-8
MAIN LIFT CYLINDERS	
THREE STAGE FULL FREE-LIFT.....	12-12
TWO STAGE LIMITED FREE-LIFT.....	10-8
MAST ELECTRICAL.....	4-30
MIRRORS	
WITH CAB.....	13-6
WITH OVERHEAD GUARD.....	13-8
MONOTROL PEDAL ASSEMBLY.....	3-38
<b>O</b>	
OIL PAN	
YANMAR 2.6L AND 3.3L DIESEL.....	2-76
OIL PUMP AND FILTER	
MAZDA 2.0L AND 2.2L LPG.....	2-26



**TABLE OF CONTENTS (Continued)**

DESCRIPTION	PAGE
<b>O</b> (continued)	
OUTER MAST	
THREE STAGE FULL FREE-LIFT .....	12-2
TWO STAGE FULL FREE-LIFT .....	11-2
TWO STAGE LIMITED FREE-LIFT .....	10-2
OUTLET SECTION	
ELECTRONIC CONTROL	
THREE AND FOUR FUNCTION .....	9-36
MANUAL CONTROL VALVE	
THREE AND FOUR FUNCTION .....	9-24
OVERHEAD GUARD .....	1-16
<b>P</b>	
PARK BRAKE ASSEMBLY .....	8-12
POWER DISTRIBUTION MODULE .....	4-18
<b>R</b>	
REMOTE OIL FILTER	
GM 2.4L	
LPG .....	2-57
REVERSE CLUTCH	
DUAL SPEED TRANSMISSION .....	5-30
SINGLE SPEED TRANSMISSION .....	5-20
<b>S</b>	
SEAT	
FULL SUSPENSION	
WITH AND WITHOUT ELECTRONIC CONTROLS .....	1-30
NON-SUSPENSION	
WITHOUT ELECTRONIC CONTROLS .....	1-34
SEMI-SUSPENSION	
WITH AND WITHOUT ELECTRONIC CONTROLS .....	1-32
SWIVEL	
WITH AND WITHOUT ELECTRONIC CONTROLS .....	1-36
STEER AXLE .....	7-10
STEER CYLINDER .....	7-12
STEER TIRES AND WHEELS	
H2.0-2.5FT .....	7-14
H2.0-3.5FT .....	7-16
STEERING COLUMN AND ATTACHING PARTS .....	7-2
STEERING COLUMN ASSEMBLY .....	7-4
STEERING CONTROL UNIT .....	7-6
STEERING LINES .....	7-8
<b>T</b>	
THROTTLE BODY AND ATTACHING PARTS	
GM 2.4L	
LPG .....	3-32
THROTTLE CABLE ASSEMBLY	
MAZDA 2.0L AND 2.2L	

## TABLE OF CONTENTS (Continued)

DESCRIPTION	PAGE
<b>T (continued)</b>	
LPG .....	3-28
YANMAR 2.6L AND 3.3L DIESEL.....	3-30
THROTTLE PEDAL AND ATTACHING PARTS MAZDA 2.0L AND 2.2L/GM 2.4L LPG .....	3-36
THROTTLE POSITION SENSOR AND ATTACHING PARTS YANMAR 2.6L AND 3.3L DIESEL.....	3-34
TILT CYLINDER AND MAST INSTALLATION .....	9-40
TILT CYLINDERS H2.0-2.5FT.....	9-42
H3.0-3.5FT.....	9-44
TILT SECTION ELECTRONIC CONTROL THREE AND FOUR FUNCTION.....	9-34
TIMING GEAR COVER AND OIL PAN MAZDA 2.0L AND 2.2L LPG .....	2-24
TORQUE CONVERTER.....	5-4
TRANSMISSION DUAL SPEED SHEET 1 OF 2 .....	5-22
SHEET 2 OF 2 .....	5-26
SINGLE SPEED SHEET 1 OF 2 .....	5-12
SHEET 2 OF 2 .....	5-16
TRANSMISSION COOLING MAZDA 2.0L AND 2.2L, LPG SERPENTINE AND SQUARE WAVE WITHOUT AIR COOLER.....	5-6
MAZDA 2.0L AND 2.2L/GM 2.4L, LPG SQUARE WAVE WITH AIR OIL COOLER.....	5-8
YANMAR 2.6L AND 3.3L DIESEL.....	5-10
TRANSMISSION ELECTRICAL SYSTEM .....	4-28
TRANSMISSION MOUNTING.....	5-2
<b>V</b>	
VALVE ASSEMBLY, LIFT AND LOWER ELECTRONIC CONTROL VALVE THREE AND FOUR FUNCTION.....	9-28
VALVE ASSEMBLY, LIFT AND TILT MANUAL CONTROL VALVE THREE AND FOUR FUNCTION.....	9-20
<b>W</b>	
WATER PUMP MAZDA 2.0L AND 2.2L LPG .....	2-36

**TABLE OF CONTENTS (Continued)**

DESCRIPTION	PAGE
<b>W</b> (continued)	
YANMAR 2.6L AND 3.3L DIESEL.....	2-90
WIRE HARNESS	
RH CHASSIS	
GM 2.4L, LPG .....	4-36
WIRE HARNESS	
COWL .....	4-50
ELECTRONIC CONTROL VALVE	
FOUR FUNCTION.....	4-56
THREE FUNCTION.....	4-54
ENGINE	
GM 2.4L, LPG .....	4-46
MAZDA 2.0L AND 2.2L, LPG .....	4-44
YANMAR 2.6L AND 3.3L, DIESEL .....	4-48
LIGHTS .....	4-58
RH CHASSIS	
MAZDA 2.0L AND 2.2L, LPG .....	4-32
YANMAR 2.6L AND 3.3L, DIESEL .....	4-40
TRANSMISSION	
DUAL SPEED.....	4-60
SINGLE SPEED.....	4-62

**SECTION 1**  
**FRAME**

DESCRIPTION	PAGE
CAB	
FRAME AND ATTACHING PARTS .....	1-28
INTERIOR PANELS .....	1-26
LH DOOR.....	1-20
RH DOOR AND HEATER ASSEMBLY .....	1-22
WINDOWS AND WINDOW WIPER SYSTEM .....	1-24
CAB AND ATTACHING PARTS .....	1-18
COUNTERWEIGHTS .....	1-14
COWL MOUNT.....	1-12
FENDER EXTENSIONS.....	1-10
FLOORPLATES AND COVERS .....	1-6
FORKS .....	1-48
OPTIONAL.....	1-49
HOOD ASSEMBLY .....	1-2
LABELS	
CONTROL LEVER.....	1-42
ELECTRONIC LEVER .....	1-44
EXTERIOR.....	1-38
INTERIOR.....	1-40
JOYSTICK.....	1-46
LOAD BACK REST EXTENSION.....	1-50
OVERHEAD GUARD.....	1-16
SEAT	
FULL SUSPENSION	
WITH AND WITHOUT ELECTRONIC CONTROLS .....	1-30
NON-SUSPENSION	
WITHOUT ELECTRONIC CONTROLS .....	1-34
SEMI-SUSPENSION	
WITH AND WITHOUT ELECTRONIC CONTROLS .....	1-32
SWIVEL	
WITH AND WITHOUT ELECTRONIC CONTROLS .....	1-36

## HOOD ASSEMBLY (Figure 1-1)

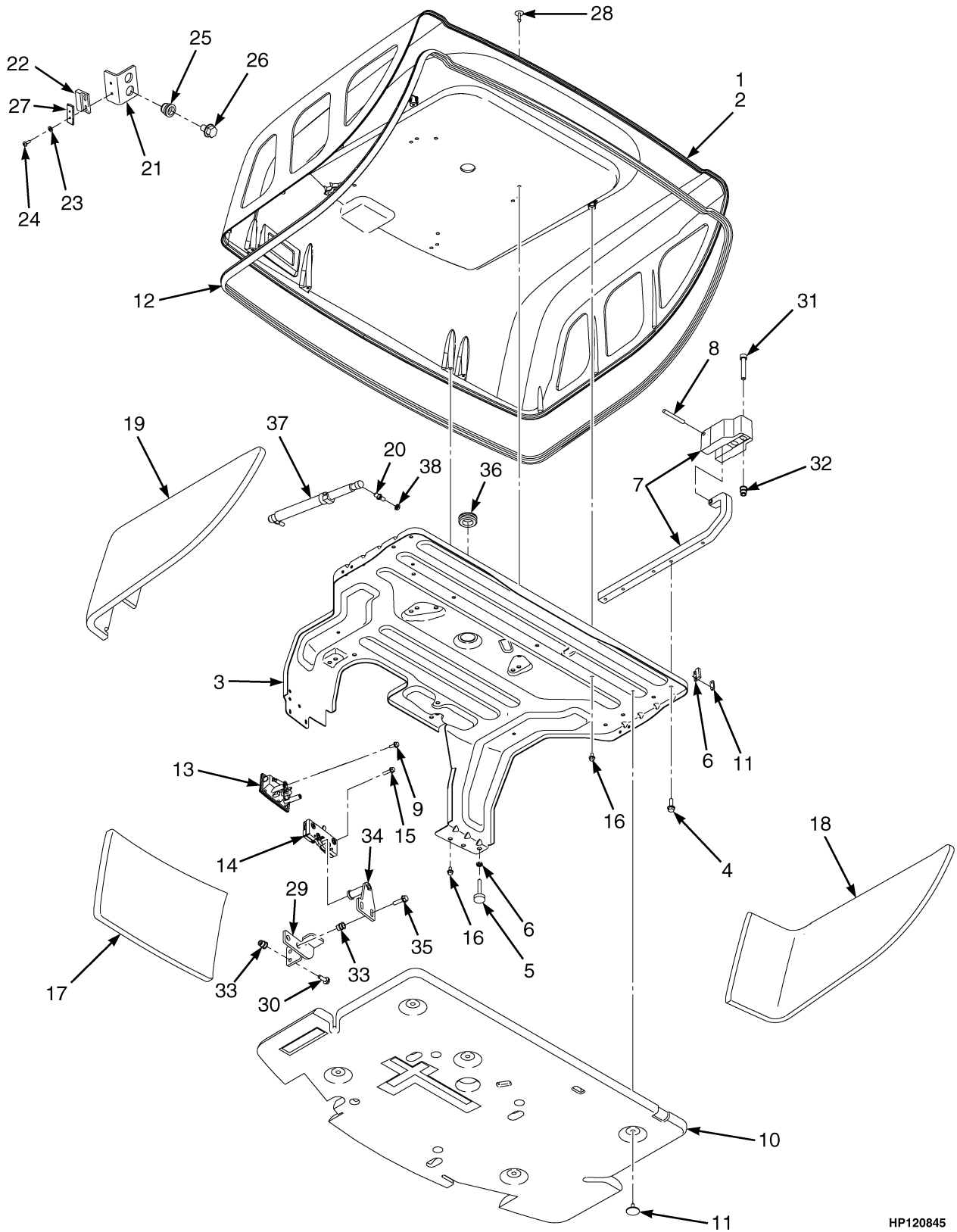

HP120845

**HOOD ASSEMBLY**

ITEM	PART NO.	DESCRIPTION	QTY
1	<b>b</b> 1589667	Hood Assembly (Low Noise) .....	1
1	<b>c</b> 1543994	Hood Assembly (Standard).....	1
1	1594927	Hood Assembly (Vented) .....	1
1	<b>ac</b> 1603215	Hood Assembly (Non-Vented) .....	1
1	<b>ab</b> 1605122	Hood Assembly (Low Noise) .....	1
1	<b>a</b> 1603216	Hood Assembly (Vented) .....	1
2	<b>b</b> 1590149	Hood (Low Noise).....	1
2	<b>c</b> 1543995	Hood (Standard).....	1
2	1594926	Hood (Vented) .....	1
2	<b>ac</b> 1603212	Hood (Non-Vented) .....	1
2	<b>ab</b> 1605121	Hood (Low Noise).....	1
2	<b>a</b> 1603214	Hood (Vented) .....	1
3	1544846	Reinforcement Assembly.....	1
4	1510113	Capscrew .....	8
5	1528906	Stop Screw .....	2
6	329069	Nut.....	4
7	1548618	Hinge Assembly .....	2
8	302380	Pin.....	2
9	1527876	Capscrew .....	2
10	1545387	Hood Liner.....	1
11	1304971	Fastener .....	4
12	1580652	Seal.....	1
13	1582287	Handle .....	1
14	1582286	Latch Rotor.....	1
15	1527878	Capscrew .....	4
16	1534417	Capscrew .....	6
17	<b>b</b> 1552010	Liner (Front Panel) (Low Noise).....	1
18	<b>b</b> 1552011	Liner (LH Panel) (Low Noise) .....	1
19	<b>b</b> 1552012	Liner (RH Panel) (Low Noise).....	1
20	<b>c</b> 1563369	Ball Stud .....	4
20	<b>b</b> 1563369	Ball Stud .....	3
20	<b>b</b> 1606659	Ball Stud .....	1
21	1527228	Bracket (Hood Switch) .....	1
22	1565545	Magnet (Reed Switch) .....	1
23	320152	Washer .....	4
24	302010	Screw.....	4
25	1531557	Insert.....	2
26	1583611	Capscrew.....	2
27	1585765	Plate .....	1
28	1347045	Fastener.....	8
29	1583672	Bumper Rest.....	1
30	1583611	Capscrew.....	2
31	296032	Capscrew.....	4
32	1530244	Insert.....	4
33	1530243	Insert.....	4
34	1584617	Striker Bolt .....	1
35	1527881	Capscrew.....	2
36	1561015	Grommet.....	1
37	<b>c</b> 1563497	Gas Spring.....	2
37	<b>b</b> 1560647	Gas Spring (LH).....	1
37	<b>b</b> 1563836	Gas Spring (RH) .....	1

## HOOD ASSEMBLY

ITEM	PART NO.	DESCRIPTION	QTY
38	329069	Nut .....	2
	a 1585592	Plug (Not Illustrated) .....	1

**FOOTNOTES:**

- a Use With Swivel Seat
- b With Cab
- c With Overhead Guard





## FLOORPLATES AND COVERS (Figure 1-2)

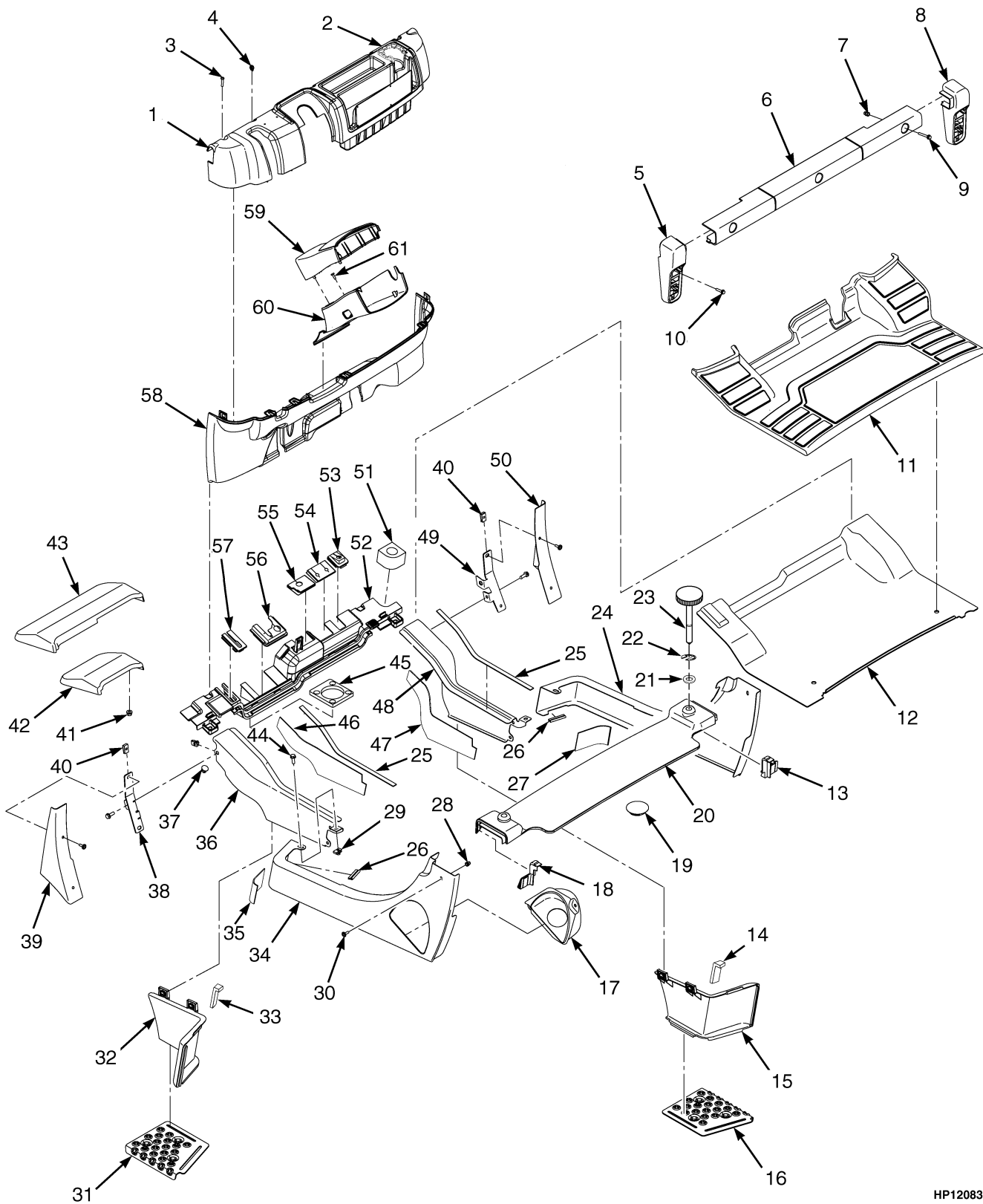

HP120831

**FLOORPLATES AND COVERS****KEY:****A: With Cab****B: With Overhead Guard**

ITEM	PART NO.	DESCRIPTION	QTY	
			A	B
1	1517420	Dash Assembly (Manual Valve) .....	1	1
1	1517421	Dash Assembly (Electronic Valve) .....	1	1
2	2070975	Cup Holder .....	1	1
3	2071261	Capscrew .....	5	5
4	2065667	Clip .....	6	6
5	2056822	Bracket (Tail Light) (LH) .....	1	1
6	2069203	Cover (Rear) .....	..	1
7	1531001	Insert .....	..	8
7	1531001	Insert .....	5	..
8	2056823	Bracket (Tail Light) (RH) .....	1	1
9	1540643	Capscrew .....	3	3
10	1586495	Capscrew .....	4	4
11	2071262	Floor Mat .....	1	1
12	1573774	Floor Plate .....	1	1
13	2070274	Seal Panel (RH) .....	1	1
14	1596624	Seal (RH) .....	1	1
15	1574277	Step Panel (RH) .....	1	1
16	1544415	Plate (RH) .....	1	1
17	1517656	Splash Shield (Diesel) .....	1	1
18	2070273	Seal Panel (LH) .....	1	1
19	2021395	Cap (LPG) .....	1	1
20	1547466	Radiator Cover Assembly .....	..	1
20	1547467	Seal (LH) .....	..	1
20	1547468	Seal (RH) .....	..	1
21	320157	Washer .....	..	2
22	353206	Snap Ring .....	..	2
23	1520970	Screw .....	..	2
24	1527946	Rear Panel (RH) .....	1	1
25	1564529	Seal .....	2	2
26	1582072	Trim Seal .....	2	2
27	1597058	Damping Sheet (RH Rear Panel) .....	1	1
28	1609707	Sound Liner .....	1	..
29	1609709	Sound Liner .....	1	..
30	1609708	Sound Liner .....	1	..
31	1609706	Sound Liner .....	1	..
32	1531558	Insert .....	6	6
33	1480237	Clip Nut (Diesel) .....	23	23
33	1480237	Clip Nut (LPG) .....	21	21
34	1530019	Screw .....	6	6
35	1544413	Plate (LH) .....	1	1
36	1574275	Step Panel (LH) .....	1	1
37	1596625	Seal (LH) .....	1	1
38	1527939	Panel (Rear) (LH, Diesel) .....	1	1
38	1527940	Panel (Rear) (LH, LPG) .....	1	1
39	1597052	Damping Sheet (LH Rear Panel) .....	1	1
40	1540860	Front Panel (LH) .....	1	1

## FLOORPLATES AND COVERS

ITEM	PART NO.	DESCRIPTION	QTY	
			A	B
41	1581079	Plug .....	4	4
42	1590145	Bracket (LH) (Fender Cover).....	1	1
43	1563881	Cover (LH) (Fender).....	1	1
44	1350215	Nut (Foldover).....	4	4
45	1544153	Lock Nut (Standard Tread, Wide Tread) .....	4	4
45	1544153	Lock Nut (Dual Tread).....	6	6
46	2069008	Mud Guard (Standard Tread).....	2	2
46	2069545	Mud Guard (RH, Wide Tread).....	1	1
46	2069954	Mud Guard (RH, Dual Tread).....	1	1
47	2069544	Mud Guard (LH, Wide Tread).....	1	1
47	2069550	Mud Guard (LH, Dual Tread) .....	1	1
48	1583611	Capscrew (Diesel) .....	23	23
48	1583611	Capscrew (LPG) .....	21	21
49	1579837	Seal (Wet Brake) .....	1	1
49	1580093	Seal (Dry Brake) .....	1	1
50	1597051	Damping Sheet (LH, Front Panel).....	1	1
51	1597070	Damping Sheet (RH, Front Panel).....	1	1
52	1540870	Front Panel (RH).....	1	1
53	1590147	Bracket (RH) (Fender Cover) .....	1	1
54	1563883	Cover (RH) (Fender) .....	1	1
55	1530135	Grommet (RH).....	1	1
56	1563840	Seal Plate Assembly.....	1	1
56	1529427	Seal .....	1	1
57	2069464	Seal .....	1	..
58	2065799	Seal (Manual Valve).....	1	..
58	2065826	Seal (Electronic Valve).....	1	..
59	2065798	Seal (Manual Valve).....	1	..
59	2065827	Seal (Electronic Valve).....	1	..
60	2065797	Seal .....	1	..
61	2065796	Seal .....	1	..
62	2071595	Kick Panel (Single Brake Pedal) .....	1	1
63	2065668	Cover (Steering Column) (Upper).....	1	1
63	2071596	Kick Panel (Dual Brake Pedal).....	1	1
64	2065666	Cover (Steering Column) (Lower).....	1	1
65	2027655	Screw.....	2	2



## FENDER EXTENSIONS (Figure 1-3)

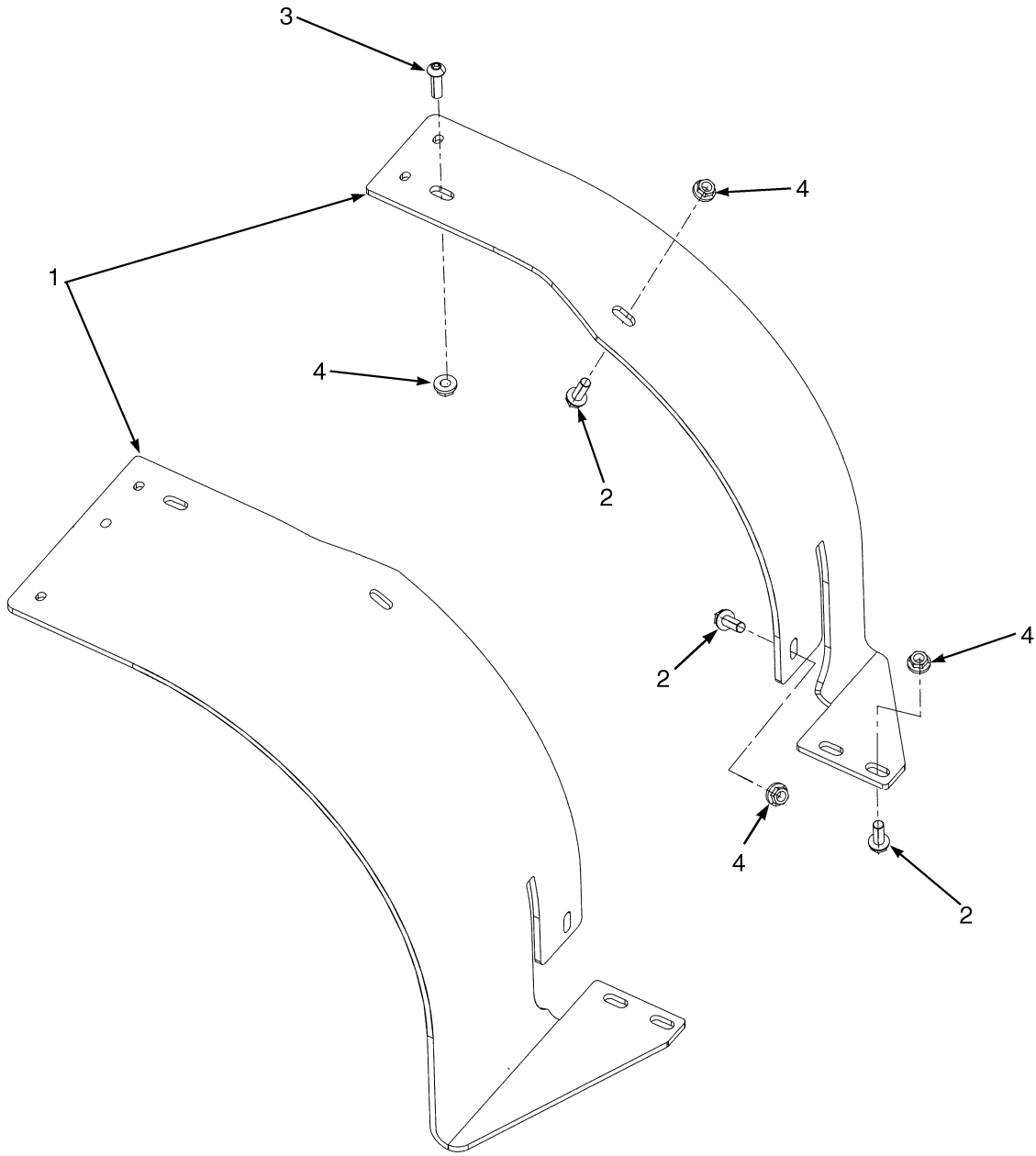

HP120835

**FENDER EXTENSIONS**

ITEM	PART NO.	DESCRIPTION	QTY
1	1562359	Fender (Wide Width) (LH).....	1
1	1562361	Fender (Dual) (LH).....	1
1	1562360	Fender (Wide Width) (RH).....	1
1	1562362	Fender (Dual) (RH).....	1
2	1586630	Capscrew.....	8
3	2076289	Capscrew.....	2
4	1586432	Nut.....	10

## COWL MOUNT (Figure 1-4)

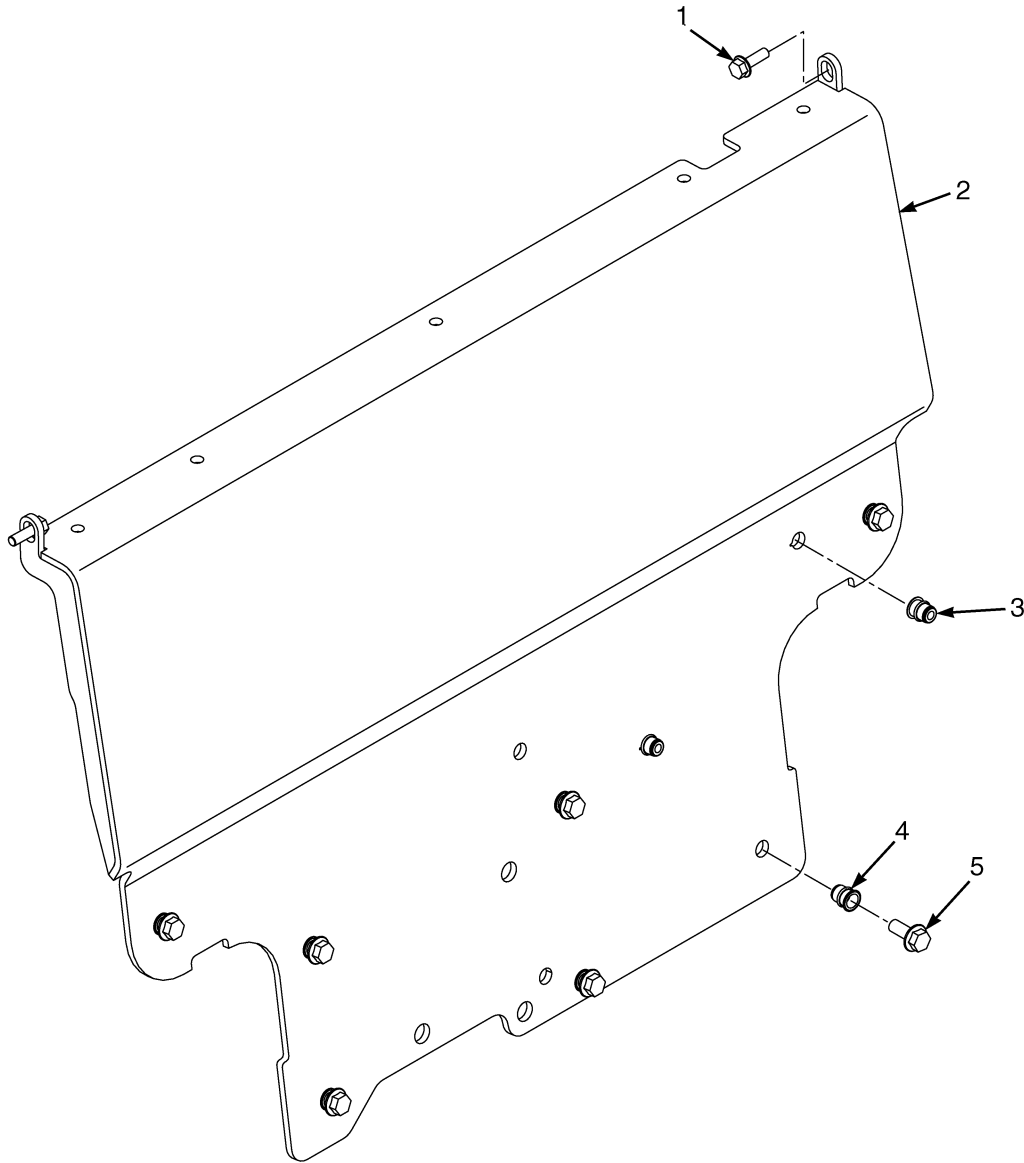

HP120730

ITEM	PART NO.	DESCRIPTION	QTY
1	1583611	Capscrew.....	2
2	1586815	Cowl.....	1
3	1530243	Insert.....	2
4	1530244	Insert.....	7
5	1605990	Capscrew.....	7





## COUNTERWEIGHTS (Figure 1-5)

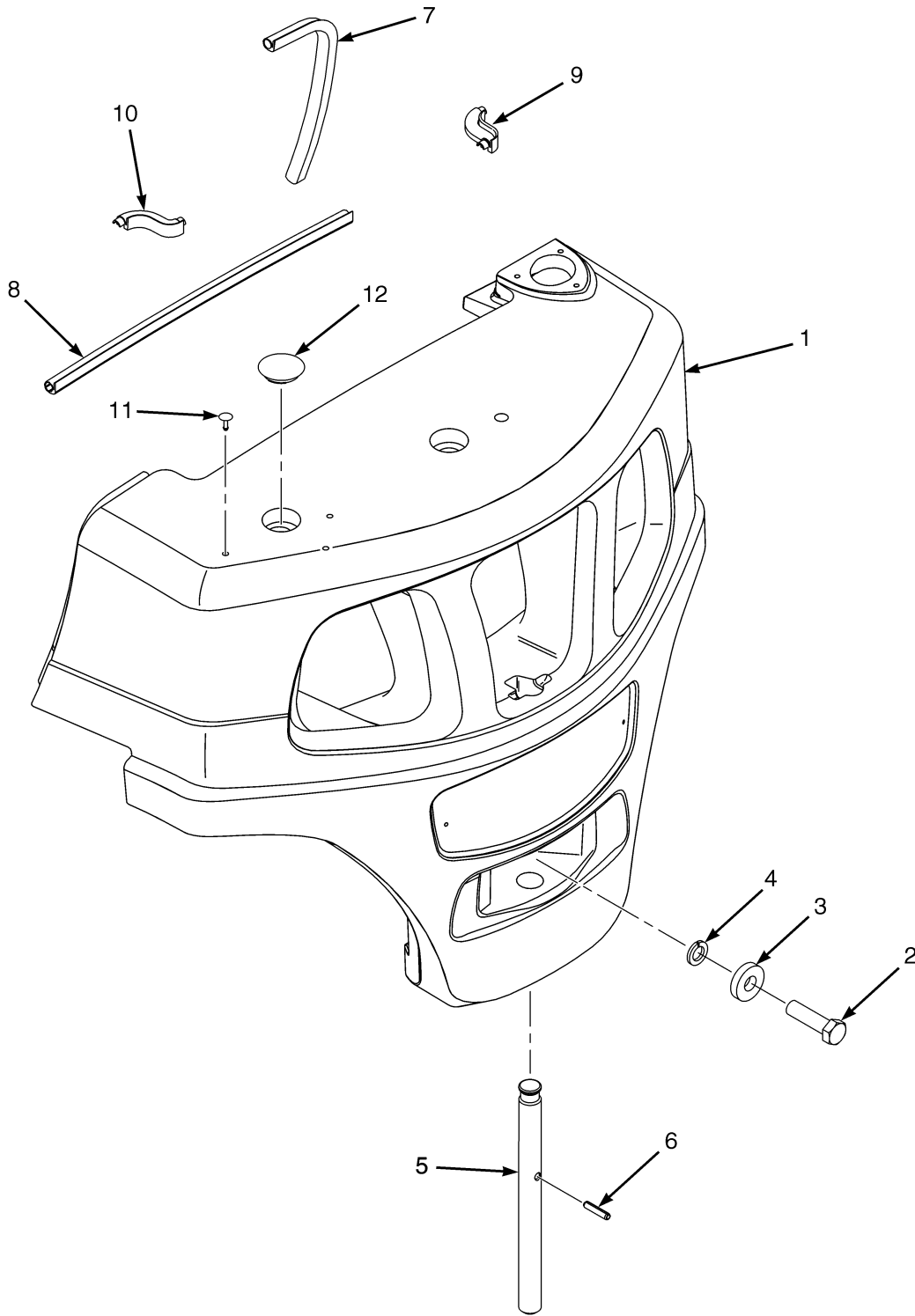

HP120833

**COUNTERWEIGHTS**

ITEM	PART NO.	DESCRIPTION	QTY
1	1533597	Counterweight (H2.0FT) .....	1
1	1533598	Counterweight (H2.5FT) .....	1
1	1533599	Counterweight (H3.0FT) .....	1
1	1533601	Counterweight (H3.5FT) .....	1
2	<b>a</b> 292608	Capscrew (101,6 mm) .....	1
2	<b>b</b> 292613	Capscrew (152,4 mm) .....	1
3	1375214	Washer .....	1
4	292689	Lockwasher.....	1
5	1533596	Pin .....	1
6	302491	Pin .....	1
7	1590279	Seal (Counterweight).....	1
8	1590280	Seal (Counterweight) (Top).....	1
9	1590152	Seal (RH).....	1
10	1590153	Seal (LH) .....	1
11	1347045	Fastener.....	4
12	2021395	Cap .....	2

**FOOTNOTES:****a** H2.0FT**b** H2.5-3.5FT

## OVERHEAD GUARD (Figure 1-6)

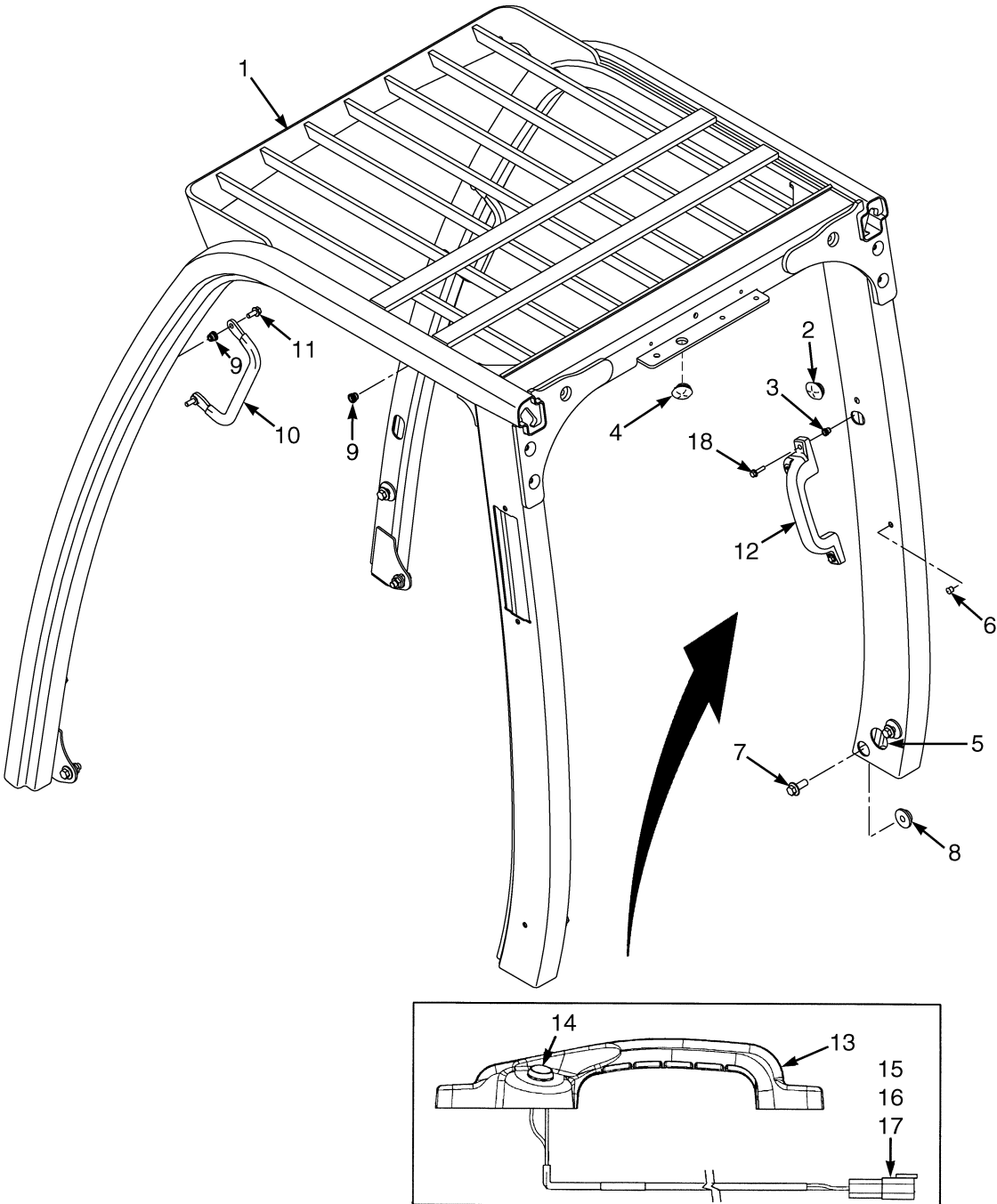

HP120756

**OVERHEAD GUARD**

ITEM	PART NO.	DESCRIPTION	QTY
1	1556574	Overhead Guard (High) .....	1
1	1556713	Overhead Guard (Low) .....	1
2	1558219	Grommet.....	3
3	1531558	Insert.....	2
4	1560671	Grommet.....	1
5	1581654	Grommet.....	1
6	1494888	Plug .....	2
7	1528889	Capscrew.....	8
8	1528888	Nut .....	2
9	1531557	Insert.....	4
10	1536813	Handle (Grab).....	1
11	1583611	Capscrew.....	2
12	2070223	Handle Assembly (RH, Rear) .....	1
13	2069454	Handle .....	1
14	1566726	Switch (Horn) .....	1
15	1493465	Connector.....	1
16	1330414	Secondary Lock.....	1
17	1330437	Terminal (Pin) .....	2
18	1586495	Capscrew.....	2

## CAB AND ATTACHING PARTS (Figure 1-7)

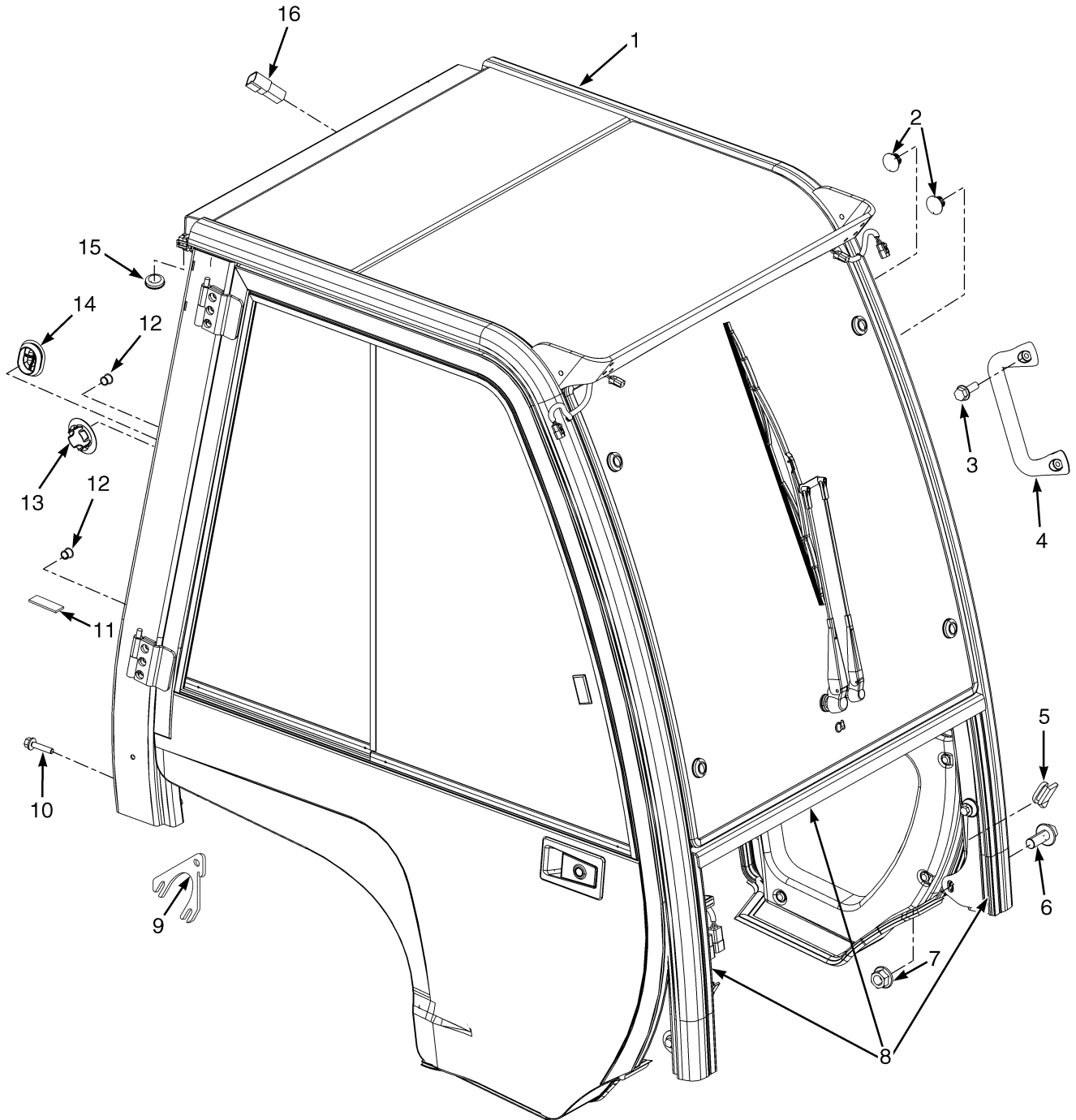

BP120157

**CAB AND ATTACHING PARTS**

ITEM	PART NO.	DESCRIPTION	QTY
1	1519232	Cab Assembly (☞ Figure 1-8, ☞ Figure 1-9, ☞ Figure 1-10, ☞ Figure 1-11, ☞ Figure 1-12) .....	1
2	1574301	Plug .....	8
3	1583611	Capscrew .....	8
4	1536813	Handle (Grab).....	1
5	1589787	Seal .....	2
6	1528889	Capscrew .....	8
7	1528888	Nut.....	2
8	1611140	Seal (Three Piece) .....	1
9	1610890	Shim .....	AR
10	1586495	Capscrew .....	6
11	1609621	Seal .....	1
12	1494888	Plug .....	2
13	1599415	Plug .....	1
14	1558219	Grommet .....	1
15	1560671	Grommet .....	1
16	1351681	Connector.....	1

## CAB (Figure 1-8) LH DOOR

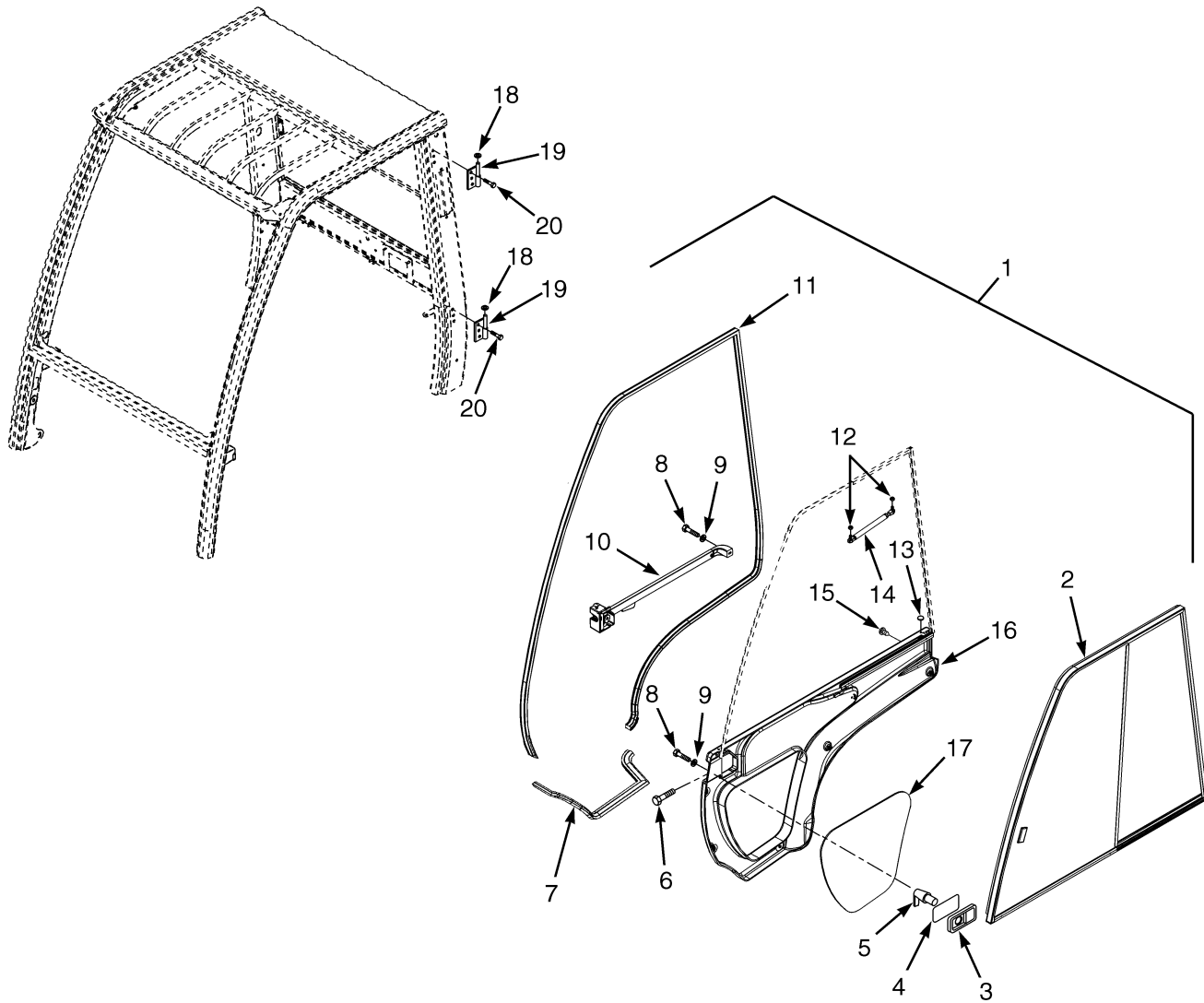

HP120861

Thank you so much for reading.  
Please click the “Buy Now!”  
button below to download the  
complete manual.



After you pay.

You can download the most  
perfect and complete manual in  
the world immediately.

Our support email:

[ebooklibonline@outlook.com](mailto:ebooklibonline@outlook.com)