

**INDUSTRIAL
DIESEL ENGINE**

**A-4JG1
MODEL**

WORKSHOP MANUAL

ISUZU MOTORS LIMITED

FOREWORD

This Workshop Manual is designed to help you perform necessary maintenance, service, and repair procedures on applicable Isuzu industrial engines.

Information contained in this Workshop Manual is the latest available at the time of publication.

Isuzu reserves the right to make changes at any time without prior notice.

This Workshop Manual is applicable to 1999 and later models.

NOTICE

Before using this Workshop Manual to assist you in performing engine service and maintenance operations, it is recommended that you carefully read and thoroughly understand the information contained in Section - 1 under the headings "General Repair Instruction" and "Notes on The Format of This Manual"

TABLE OF CONTENTS

SECTION 1.	GENERAL INFORMATION.....	1
SECTION 2.	MAINTENANCE	17
SECTION 3.	ENGINE ASSEMBLY (1) (DISASSEMBLY)	29
SECTION 4.	ENGINE ASSEMBLY (2) (INSPECTION AND REPAIR)	47
SECTION 5.	ENGINE ASSEMBLY (3) (REASSEMBLY)	81
SECTION 6.	LUBRICATING SYSTEM.....	109
SECTION 7.	COOLING SYSTEM	121
SECTION 8.	FUEL SYSTEM.....	127
SECTION 9.	ENGINE ELECTRICALS	141
SECTION 10.	TROUBLESHOOTING.....	169
SECTION 11.	SPECIAL TOOL LIST	195
SECTION 12.	REPAIR STANDARDS	199
SECTION 13.	CONVERSION TABLE.....	213

SECTION 1

GENERAL INFORMATION

TABLE OF CONTENTS

ITEM	PAGE
General repair instructions	2
Notes on the format of this manual	2
Main data and specifications	6
Tightening torque specifications	7

GENERAL REPAIR INSTRUCTIONS

1. Before performing any service operation with the engine mounted, disconnect the grounding cable from the battery.
This will reduce the chance of cable damage and burning due to short circuiting.
2. Always use the proper tool or tools for the job at hand.
Where specified, use the specially designed tool or tools.
3. Use genuine ISUZU parts.
4. Never reuse cotter pins, gaskets, O-rings, lock washers, and self locking nuts. Discard them as you remove them. Replace them with new ones.
5. Always keep disassembled parts neatly in groups. This will ensure a smooth reassembly operation.
It is especially important to keep fastening parts separate. These parts vary in hardness and design, depending on their installation position.
6. All parts should be carefully cleaned before inspection or reassembly.
Oil ports and other openings should be cleaned with compressed air to make sure that they are completely free of obstructions.
7. Rotating and sliding part surfaces should be lubricated with oil or grease before reassembly.
8. If necessary, use a sealer on gaskets to prevent leakage.
9. Nut and bolt torque specifications should be carefully followed.
10. Always release the air pressure from any machine-mounted air tank(s) before dismantling the engine or disconnecting pipes and hoses. To not do so is extremely dangerous.
11. Always check and recheck your work. No service operation is complete until you have done this.

NOTES ON THE FORMAT OF THIS MANUAL

This Workshop Manual is applicable to ISUZU industrial engine or engines which is or are stated in the title.

When more than two engine models are dealt in the manual, such engines have common parts and components as well as data and specifications, unless otherwise specified.

1. Find the applicable section by referring to the Table of Contents at the beginning of the Manual.
2. Common technical data such as general maintenance items, service specifications, and tightening torques are included in the "General Information" section.
The section ENGINE ASSEMBLY is an exception. This parts are divided in three sections to facilitates indexing.
3. Each section is divided into sub-sections dealing with disassembly, inspection and repair, and reassembly.

4. When the same servicing operation is applicable to several different units, the manual will direct you to the appropriate page.
5. For the sake of brevity, self-explanatory removal and installation procedures are omitted. More complex procedures are covered in detail.
6. Each service operation section in this Workshop Manual begins with an exploded view of the applicable area. A brief explanation of the notation used follows.

Parts marked with an asterisk (*) are included in the repair kit.

Parts within a square frame are to be removed and installed as a single unit, and their disassembly steps or reassembly steps are shown in the illustrations respectively.

The number tells you the service operation sequence.

Removal of unnumbered parts is unnecessary unless replacement is required.

The “* Repair Kit” indicates that a repair kit is available.

The parts listed under “Disassembly Steps” or “Reassembly Steps” are in the service operation sequence.

The removal or installation of parts marked with a triangle (▲) is an important operation. Detailed information is given in the text.

Disassembly Steps - 2

<ol style="list-style-type: none"> 1. Water by-pass hose 2. Thermostat housing 3. Water pump ▲ 4. Injection nozzle holder 5. Glow plug and glow plug connector 6. Cylinder head cover ▲ 7. Rocker arm shaft and rocker arm 8. Push rod ▲ 9. Cylinder head 	<ol style="list-style-type: none"> 10. Cylinder head gasket ▲ 11. Crankshaft damper pulley with dust seal 12. Timing gear case cover 13. Timing gear cover 14. Timing gear oil pipe 15. Idler gear “B” and shaft ▲ 16. Idler gear “A” ▲ 17. Idler gear shaft
--	--

Inverted Engine

7. Below is a sample of the text of the Workshop Manual.

4. Camshaft Timing Gear ←

- 1) Install the thrust plate ①
- 2) Apply engine oil to the bolt threads ②
- 3) Install the camshaft timing gear with the timing mark stamped side facing out

Camshaft Timing Gear Bolt Torque kgf·m(lb.ft./N·m)

11.0 ± 1.0 (79.5 ± 7.2/107.8 ± 9.8)

13. Crankshaft Rear Oil Seal

- 1) Apply engine oil to the oil seal lip circumference and the oil seal outer circumference
- 2) Use the oil seal installer to install the oil seal to the cylinder body

Oil Seal Installer: 5-8840-0141-0

14. Flywheel Housing

- 1) Apply liquid gasket to the shaded area shown in the illustration.
- 2) Tighten the flywheel housing bolts to the specified torque a little at a time in the sequence shown in the illustration.

Flywheel Housing Bolt Torque kgf·m(lb.ft./N·m)

M10×1.25 (0.40×0.05) Bolt	5.8 ± 1.0 (40.5 ± 7.2/ 54.9 ± 9.8)
M12×1.25 (0.47×0.05) Bolt	10.5 ± 1.0 (76.0 ± 7.2/ 103.0 ± 9.8)
M12×1.75 (0.47×0.07) Bolt	9.8 ± 1.0 (71.0 ± 7.2/ 96.0 ± 9.8)

This is the item shown in the illustration. It is marked with a triangle (▲) on the Major Components page.

Letters and numbers contained in a circle refer to the illustration.

Special tools are identified by the tool name and/or number. The illustration shows how the special tool is to be used.

Symbols indicate the type of service operation or step to be performed. A detailed explanation of these symbols follows.

Service data and specifications are given in this table.

8. The following symbols appear throughout this Workshop Manual. They tell you the type of service operation or step to perform.

- Removal
- Installation
- Disassembly
- Reassembly
- Alignment (marks)
- Directional indication
- Inspection
- Measurement
- Adjustment
- Cleaning
- Important operation requiring extra care
- Specified torque (tighten)
- Special tool use required or recommended (Isuzu tool or tools)
- Commercially available tool use required or recommended
- Lubrication (oil)
- Lubrication (grease)
- Sealant application

9. Measurement criteria are defined by the terms "standard" and "limit".

A measurement falling within the "standard" range indicates that the applicable part or parts are serviceable.

"Limit" should be thought of as an absolute value.

A measurement which is outside the "limit" indicates that the applicable part or parts must be either repaired or replaced.

10. Components and parts are listed in the singular form throughout the Manual.

11. Directions used in this Manual are as follows:

Front

The cooling fan side of the engine viewed from the flywheel.

Right

The right hand side viewed from the same position.

Left

The left hand side viewed from the same position.

Rear

The flywheel side of the engine.

Cylinder numbers are counted from the front of the engine.

The front most cylinder is No. 1 and rear most cylinder is the final cylinder number of the engine.

The engine's direction of rotation is counterclockwise viewed from the flywheel.

MAIN DATA AND SPECIFICATIONS

Engine Model		A-4JG1
Item		
Engine type		Water cooled, four-cycle, in-line, overhead valve
Combustion chamber type		Direct injection
Cylinder liner type		Dry
No. of cylinders - Bore x Stroke	mm(in.)	4 - 95.4 x 107
Total piston displacement	lit(cid)	3.059 (186.7)
Compression ratio (To 1)		18.6
*Engine dimensions	mm(in.)	739 x 625 x 746
Length x Width x Height		(29.1 x 24.6 x 29.4)
*Engine weight (Dry)	kg(lb.)	248 (547)
Fuel injection order		1 - 3 - 4 - 2
*Fuel injection timing (B.T.D.C.)	degrees	16
Specified fuel		Diesel fuel
Injection pump		In-line plunger, Bosch A type
Governor		Variable speed mechanical type
*Low idle speed	min ⁻¹	850 - 1,000
Injection nozzle		Multi-hole type
Injection starting pressure	MPa(kgf/cm ² /psi)	18.1 (185/2630)
Fuel filter type		Cartridge paper element
Water sedimentor (if so equipped)		Sediment/water level indicating type
Compression pressure	MPa(kgf/cm ² /psi)	3.04 (31/441)
Valve clearance (at cold)	Intake mm(in.)	0.40 (0.0157)
	Exhaust mm(in.)	0.40 (0.0157)
Lubrication method		Pressurized circulation
Oil pump		Trochoid type
Main oil filter type		Cartridge paper element, full flow
Partial oil filter		Not equipped
*Lubricating oil volume	lit.(qts)	7.6 - 9.6 (Oil pan)
Oil cooler (if so equipped)		Water cooled built in oil filter
Cooling method		Pressurized forced circulation
Coolant volume	lit.(qts)	5.0 (5.3)
Water pump		Belt driven, impeller type
Thermostat type		Wax pellet type
*Alternator	V-A	12 - 50
*Starter	V-kW	12 - 2.2









Specifications marked with an asterisk (*) will vary according to engine application.

TIGHTENING TORQUE SPECIFICATIONS

The tightening torque values given in the table below are applicable to the bolts unless otherwise specified.

STANDARD BOLT

N·m (kgf·m)

Bolt Identification Bolt Diameter × pitch (mm)				
				
M 6 × 1.0	3.9 ~ 7.8 { 0.4 ~ 0.8 }	4.9 ~ 9.8 { 0.5 ~ 1.0 }		
M 8 × 1.25	7.8 ~ 17.7 { 0.8 ~ 1.8 }	11.8 ~ 22.6 { 1.2 ~ 2.3 }	16.7 ~ 30.4 { 1.7 ~ 3.1 }	
M10 × 1.25	20.6 ~ 34.3 { 2.1 ~ 3.5 }	27.5 ~ 46.1 { 2.8 ~ 4.7 }	37.3 ~ 62.8 { 3.8 ~ 6.4 }	
* M10 × 1.5	19.6 ~ 33.4 { 2.0 ~ 3.4 }	27.5 ~ 45.1 { 2.8 ~ 4.6 }	36.3 ~ 59.8 { 3.7 ~ 6.1 }	
M12 × 1.25	49.1 ~ 73.6 { 5.0 ~ 7.5 }	60.8 ~ 91.2 { 6.2 ~ 9.3 }	75.5 ~ 114.0 { 7.7 ~ 11.6 }	
* M12 × 1.75	45.1 ~ 68.7 { 4.6 ~ 7.0 }	56.9 ~ 84.4 { 5.8 ~ 8.6 }	71.6 ~ 107.0 { 7.3 ~ 10.9 }	
M14 × 1.5	76.5 ~ 115.0 { 7.8 ~ 11.7 }	93.2 ~ 139.0 { 9.5 ~ 14.2 }	114.0 ~ 171.0 { 11.6 ~ 17.4 }	
* M14 × 2.0	71.6 ~ 107.0 { 7.3 ~ 10.9 }	88.3 ~ 131.0 { 9.0 ~ 13.4 }	107.0 ~ 160.0 { 10.9 ~ 16.3 }	
M16 × 1.5	104.0 ~ 157.0 { 10.6 ~ 16.0 }	135.0 ~ 204.0 { 13.8 ~ 20.8 }	160.0 ~ 240.0 { 16.3 ~ 24.5 }	
* M16 × 2.0	100.0 ~ 149.0 { 10.2 ~ 15.2 }	129.0 ~ 194.0 { 13.2 ~ 19.8 }	153.0 ~ 230.0 { 15.6 ~ 23.4 }	
M18 × 1.5	151.0 ~ 226.0 { 15.4 ~ 23.0 }	195.0 ~ 293.0 { 19.9 ~ 29.9 }	230.0 ~ 345.0 { 23.4 ~ 35.2 }	
* M18 × 2.5	151.0 ~ 226.0 { 15.4 ~ 23.0 }	196.0 ~ 294.0 { 20.0 ~ 30.0 }	231.0 ~ 346.0 { 23.6 ~ 35.3 }	
M20 × 1.5	206.0 ~ 310.0 { 21.0 ~ 31.6 }	270.0 ~ 405.0 { 27.5 ~ 41.3 }	317.0 ~ 476.0 { 32.3 ~ 48.5 }	
* M20 × 2.5	190.0 ~ 286.0 { 19.4 ~ 29.2 }	249.0 ~ 375.0 { 25.4 ~ 38.2 }	293.0 ~ 440.0 { 29.9 ~ 44.9 }	
M22 × 1.5	251.0 ~ 414.0 { 25.6 ~ 42.2 }	363.0 ~ 544.0 { 37.0 ~ 55.5 }	425.0 ~ 637.0 { 43.3 ~ 64.9 }	
* M22 × 2.5	218.0 ~ 328.0 { 22.2 ~ 33.4 }	338.0 ~ 507.0 { 34.5 ~ 51.7 }	394.0 ~ 592.0 { 40.2 ~ 60.4 }	
M24 × 2.0	359.0 ~ 540.0 { 36.6 ~ 55.0 }	431.0 ~ 711.0 { 43.9 ~ 72.5 }	554.0 ~ 831.0 { 56.5 ~ 84.7 }	
* M24 × 3.0	338.0 ~ 507.0 { 34.5 ~ 51.7 }	406.0 ~ 608.0 { 41.4 ~ 62.0 }	521.0 ~ 782.0 { 53.1 ~ 79.7 }	



An asterisk (*) indicates that the bolts are used for female threaded parts that are made of soft materials such as casting.

TIGHTENING TORQUE SPECIFICATIONS

The tightening torque values given in the table below are applicable to the bolts unless otherwise specified.

FLANGED HEAD BOLT

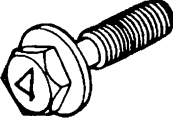
N·m (kgf·m)

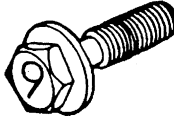
Bolt Identification Bolt Diameter × pitch (mm)			
M 6 × 1.0	4.6 ~ 8.5 { 0.5 ~ 0.9 }	6.6 ~ 12.2 { 0.6 ~ 1.2 }	—————
M 8 × 1.25	10.5 ~ 19.6 { 1.1 ~ 2.0 }	15.3 ~ 28.4 { 1.6 ~ 2.9 }	18.1 ~ 33.6 { 2.1 ~ 3.4 }
M10 × 1.25	23.1 ~ 38.5 { 2.4 ~ 3.9 }	35.4 ~ 58.9 { 3.6 ~ 6.1 }	42.3 ~ 70.5 { 4.3 ~ 7.2 }
* M10 × 1.5	22.3 ~ 37.2 { 2.3 ~ 3.8 }	34.5 ~ 57.5 { 3.5 ~ 5.8 }	40.1 ~ 66.9 { 4.1 ~ 6.8 }
M12 × 1.25	54.9 ~ 82.3 { 5.6 ~ 8.4 }	77.7 ~ 117.0 { 7.9 ~ 11.9 }	85.0 ~ 128.0 { 8.7 ~ 13.0 }
* M12 × 1.75	51.0 ~ 76.5 { 5.2 ~ 7.8 }	71.4 ~ 107.0 { 7.3 ~ 10.9 }	79.5 ~ 119.0 { 8.1 ~ 12.2 }
M14 × 1.5	83.0 ~ 125.0 { 8.5 ~ 12.7 }	115.0 ~ 172.0 { 11.7 ~ 17.6 }	123.0 ~ 185.0 { 12.6 ~ 18.9 }
* M14 × 2.0	77.2 ~ 116.0 { 7.9 ~ 11.8 }	108.0 ~ 162.0 { 11.1 ~ 16.6 }	116.0 ~ 173.0 { 11.8 ~ 17.7 }
M16 × 1.5	116.0 ~ 173.0 { 11.8 ~ 17.7 }	171.0 ~ 257.0 { 17.4 ~ 26.2 }	177.0 ~ 265.0 { 18.0 ~ 27.1 }
* M16 × 2.0	109.0 ~ 164.0 { 11.2 ~ 16.7 }	163.0 ~ 244.0 { 16.6 ~ 24.9 }	169.0 ~ 253.0 { 17.2 ~ 25.8 }

A bolt with an asterisk (*) is used for female screws of soft material such as cast iron.



SPECIAL PARTS FIXING NUTS AND BOLTS

Cylinder Head Cover, Cylinder Head, and Rocker Arm Shaft Bracket

N·m (kgf·m/lb.ft)

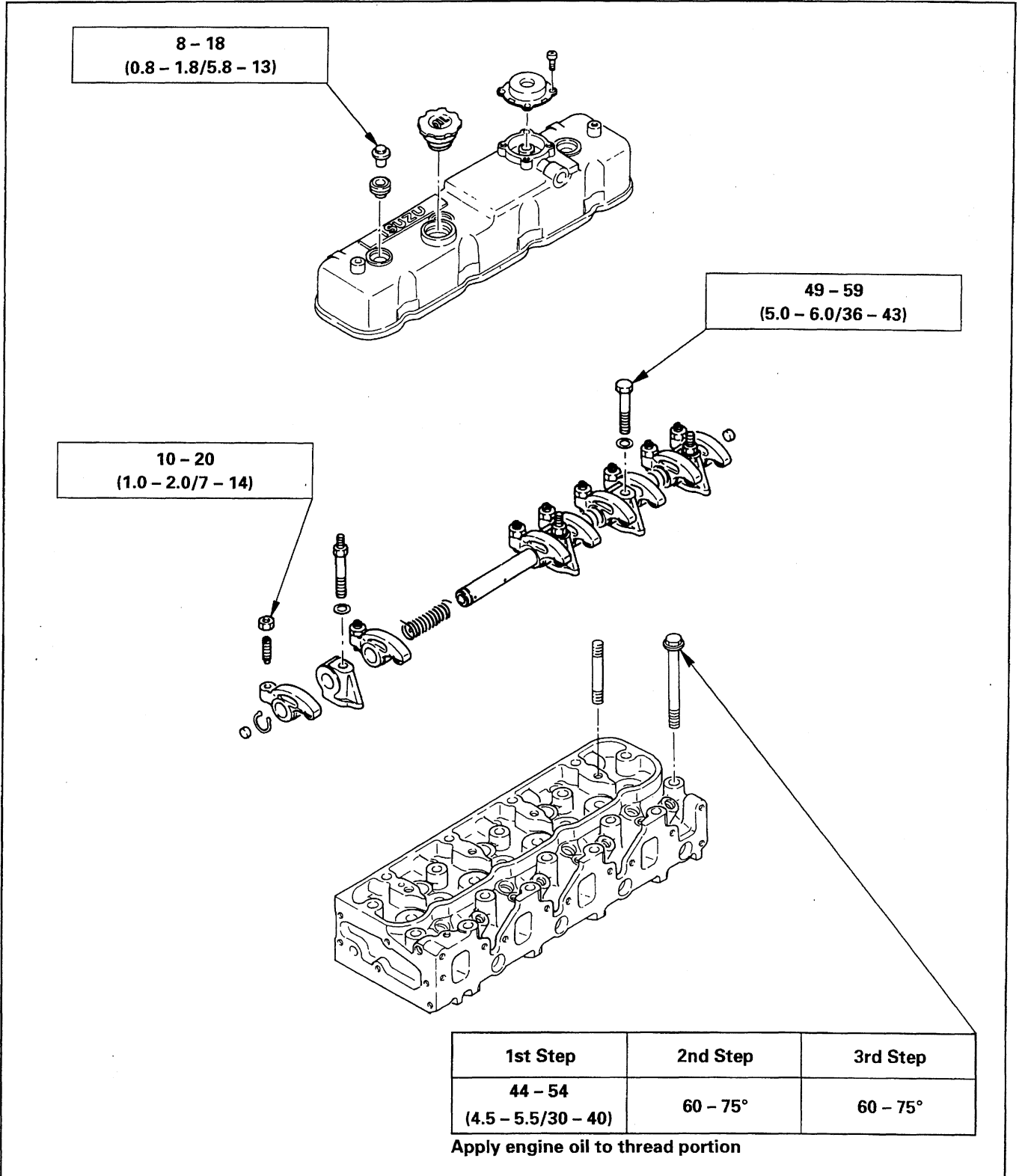



Crankshaft Bearing Cap, Connecting Rod Bearing Cap, Crankshaft Damper Pulley, Flywheel, and Oil Pan

N·m (kgf·m/lb.ft)

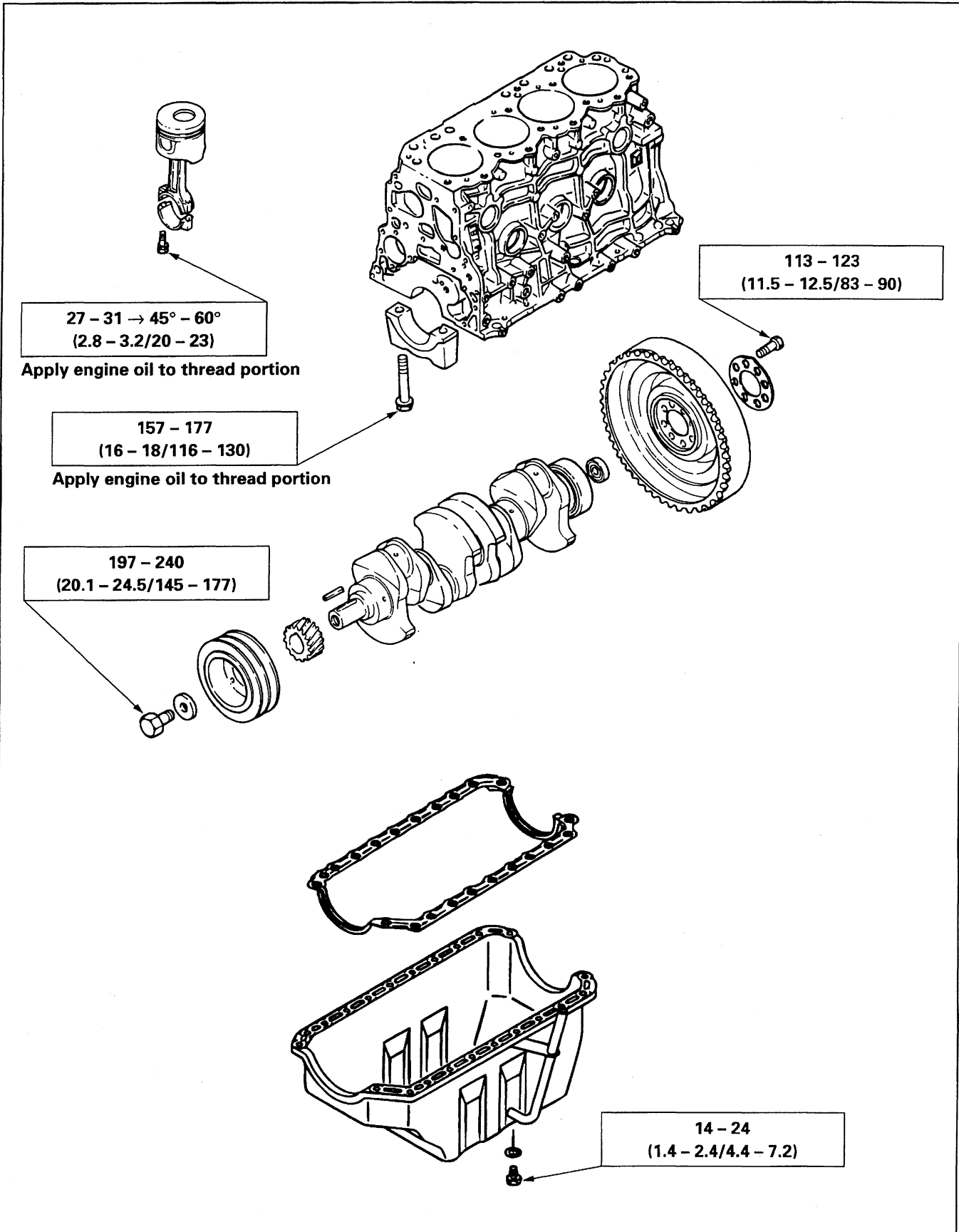



Timing Gear Case, Flywheel Housing, Camshaft, and Timing Gear

N·m (kgf·m/lb.ft)

M10 x 1.25	35 - 45 (3.6 - 4.6/26 - 33)
M12 x 1.5	74 - 91 (7.5 - 9.3/54 - 67)

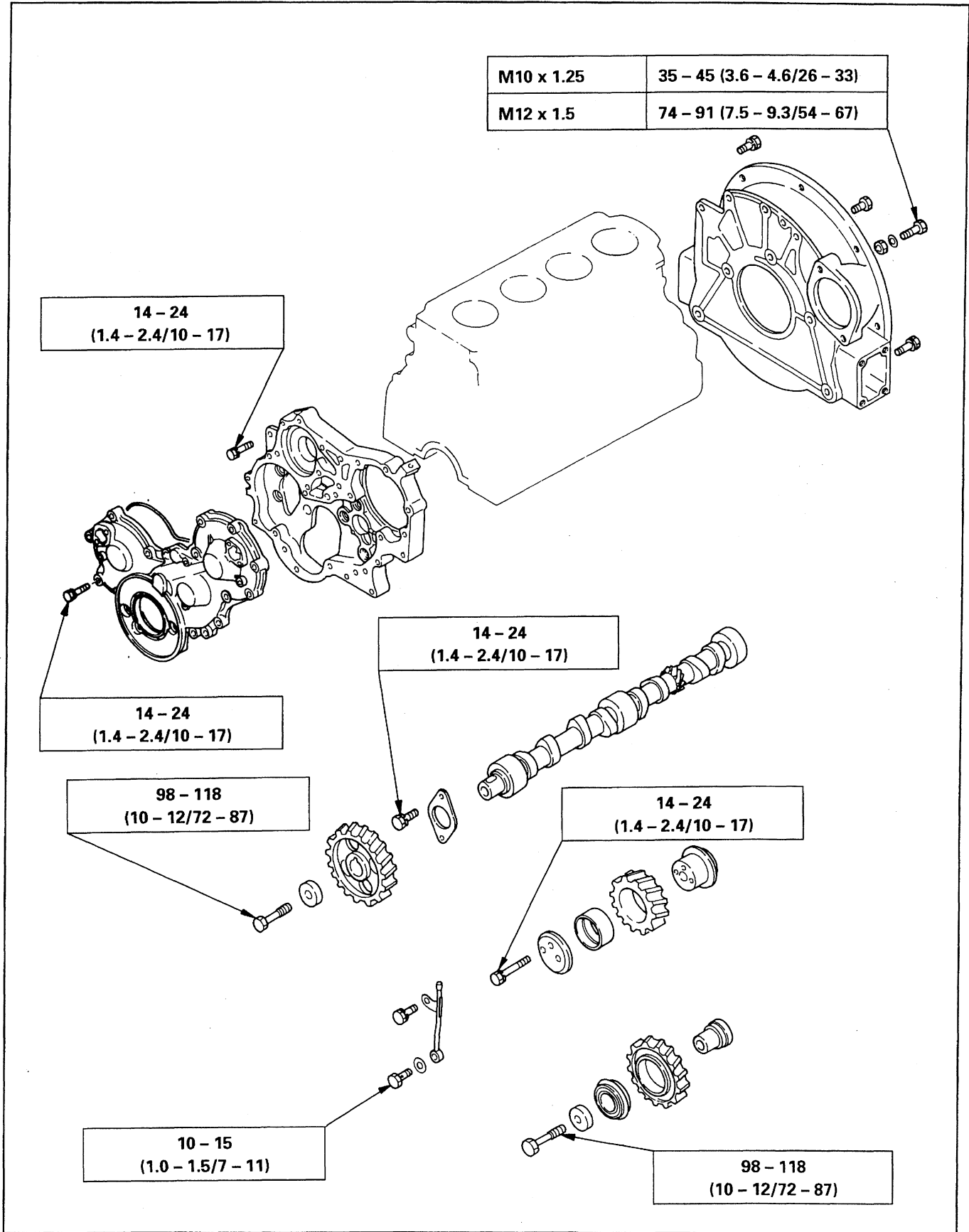



Cooling and Lubricating System

N·m (kgf·m/lb.ft)

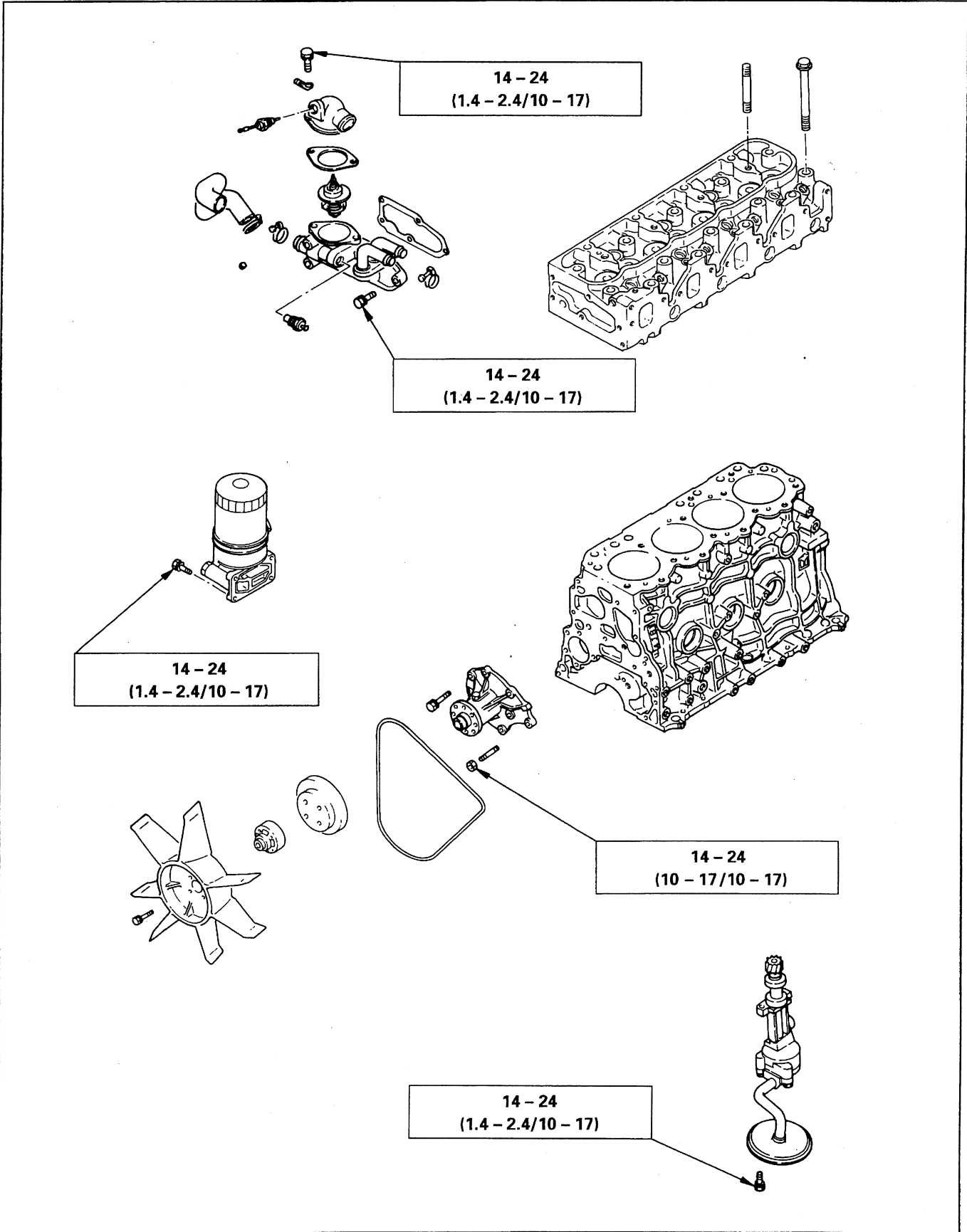



Intake and Exhaust Manifold

N·m (kgf·m/lb.ft)

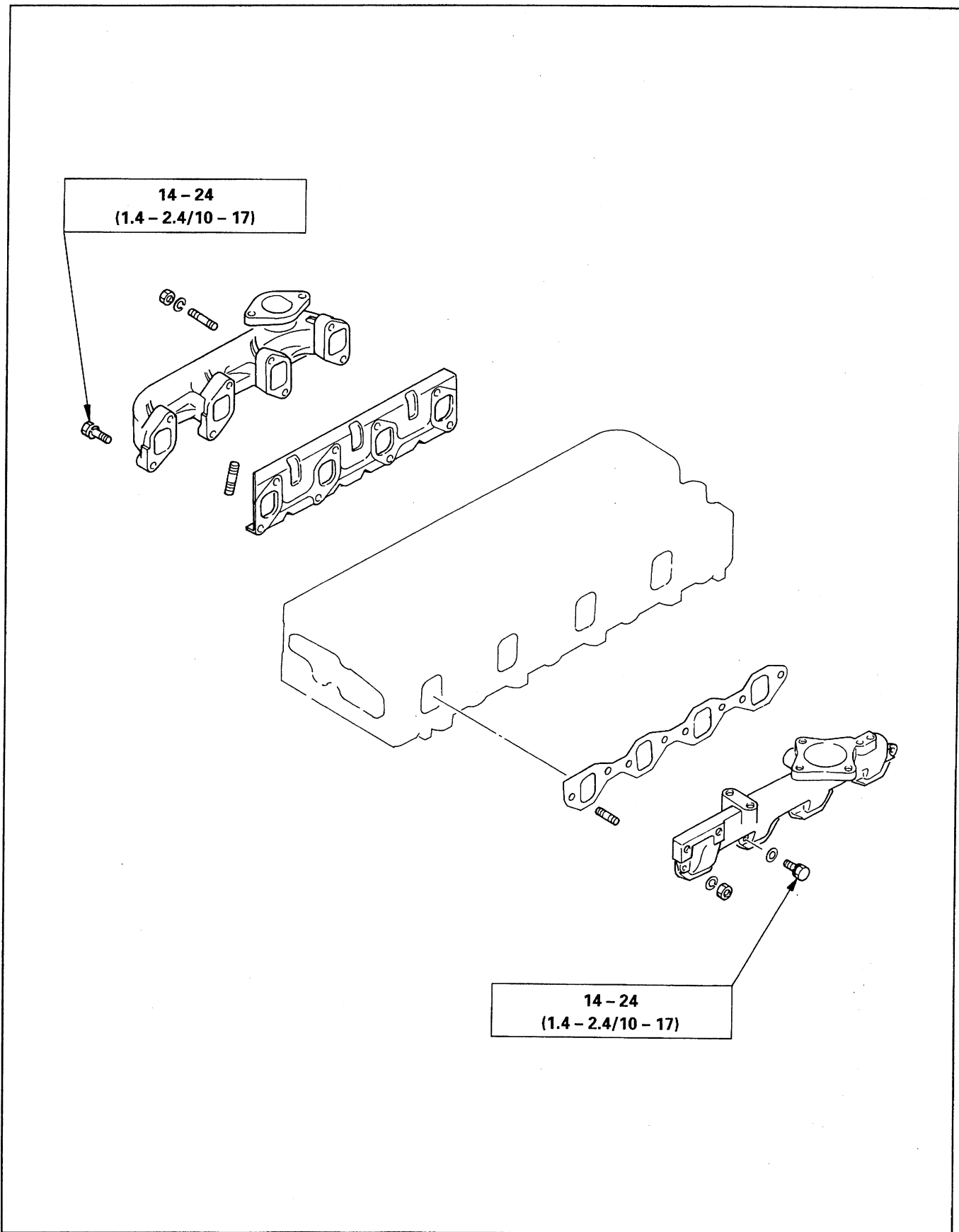



Engine Electrical

N·m (kgf·m/lb.ft)

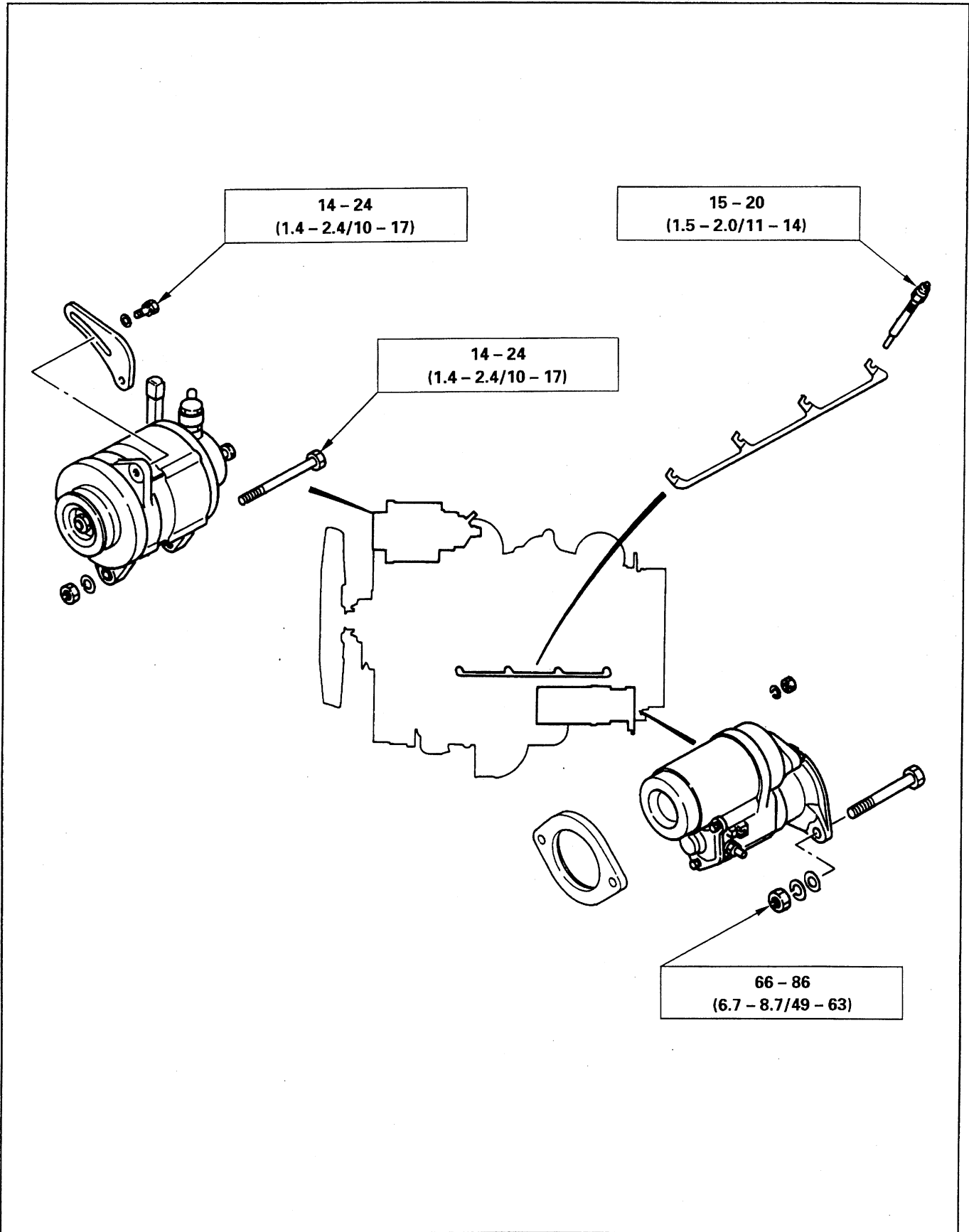



Fuel Injection System

N·m (kgf·m/lb.ft)

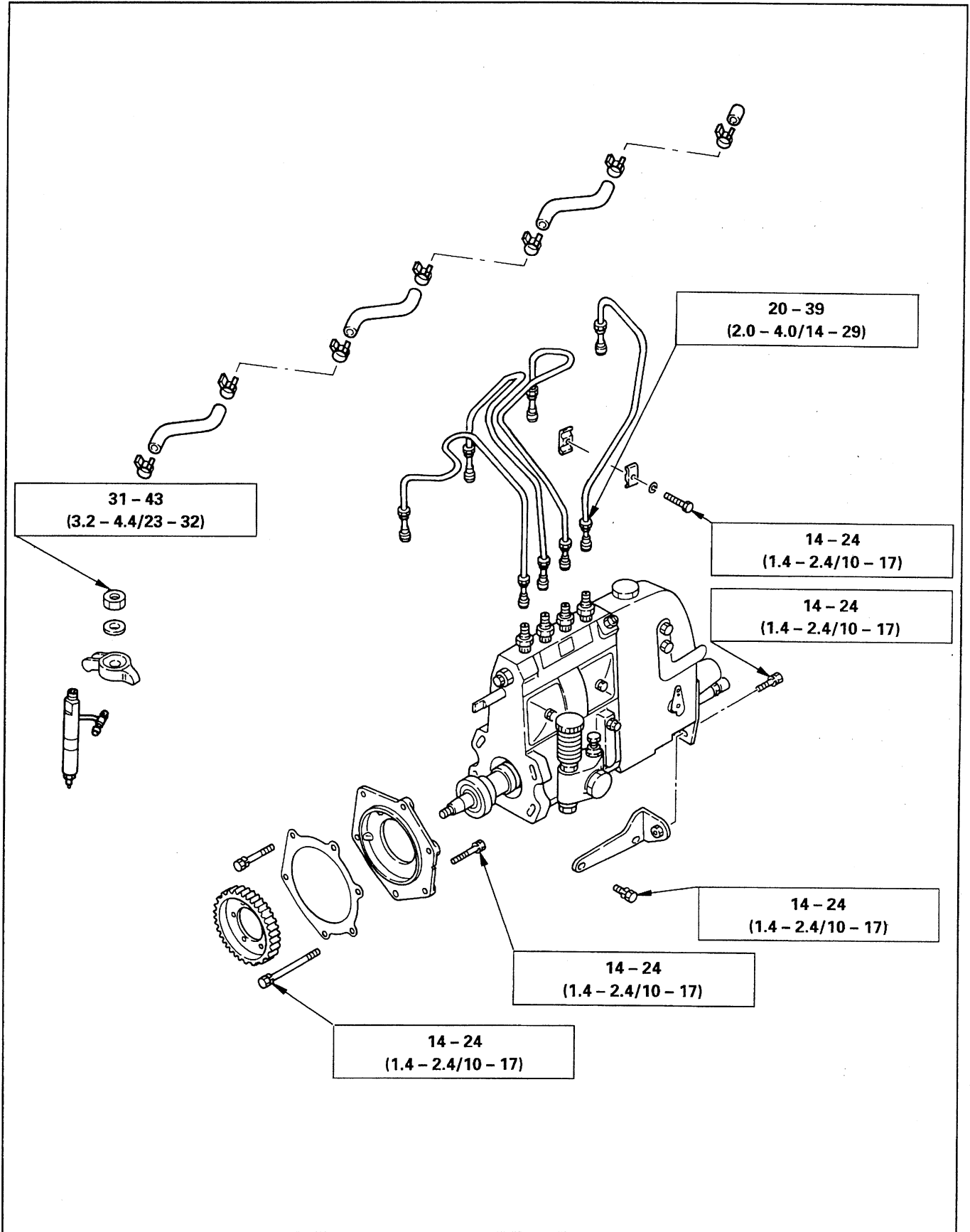

Thank you so much for reading.
Please click the “Buy Now!”
button below to download the
complete manual.



After you pay.

You can download the most
perfect and complete manual in
the world immediately.

Our support email:

ebooklibonline@outlook.com