

OPERATOR'S MANUAL

GYROTEDDER

TD1123



CONTENTS

■ Dear Owner	1
■ Contents	2
■ Identification of the machine	4
Front view (transport position).....	4
Rear view (working position).....	4
Model identification plate.....	5
Optional equipments	5
■ Safety	6
Description of symbols used in this document.....	6
Safety instructions.....	7
Location and description of safety decals on the machine.....	15
Road safety equipment and recommendations	19
■ Machine specifications.....	20
Description and glossary	20
Technical specifications.....	21
Sound levels.....	21
■ Putting into service.....	22
Description of control elements	22
Coupling and uncoupling.....	22
■ Instructions for transport.....	26
Putting the machine into transport position	26
Conformity with the road regulations	28

■ Instructions for work.....	29
Putting the machine into work position	29
Adjustments in working position	31
Machine use	33
■ Optional equipments	34
DUPLEX gearbox	34
■ Maintenance and storage	36
Frequency chart.....	36
Lubrication	37
Maintenance	40
Storage	42

IDENTIFICATION OF THE MACHINE

1. Front view (transport position)

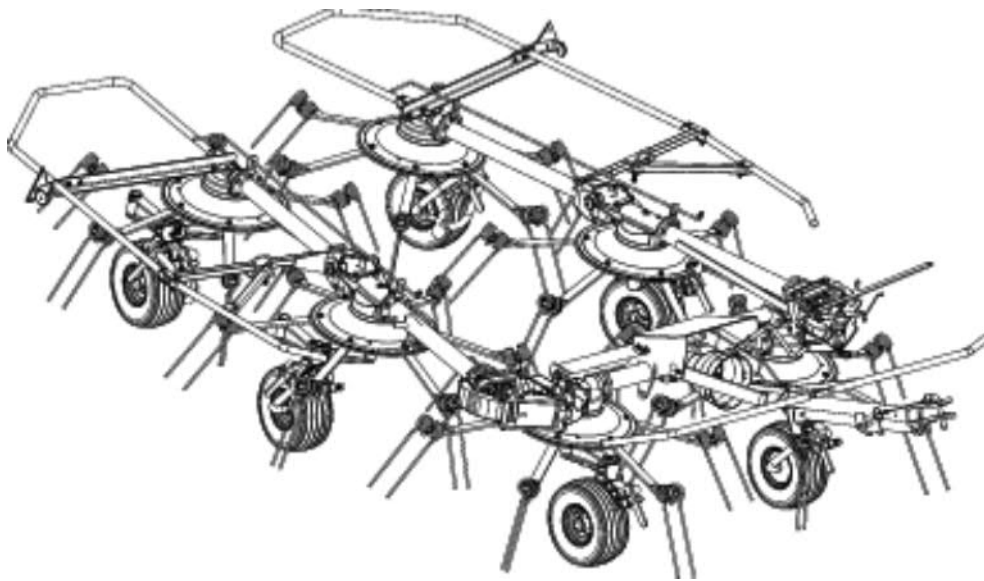

2. Rear view (working position)

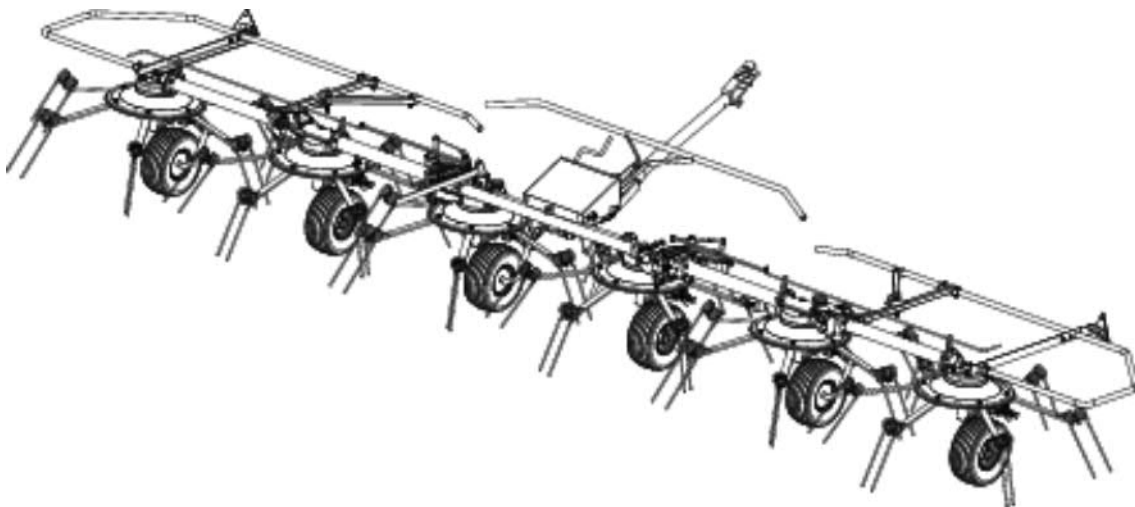

3. Model identification plate

Please write below the type and serial number of the machine. This information is to be indicated to the dealer for all spare parts orders.

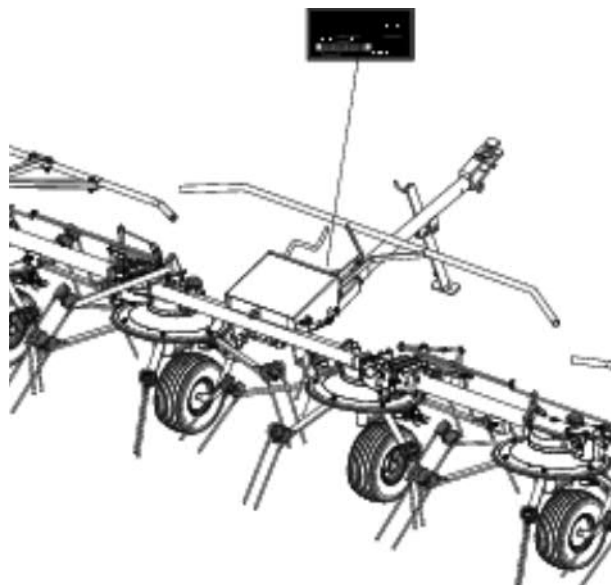

Type: TD1123

No:



4. Optional equipments

- Part no. 1126060: DUPLEX gearbox.

SAFETY

1. Description of symbols used in this document

This symbol indicates a potentially hazardous situation that if not avoided, could result in serious bodily injury.



This symbol is used to identify special instructions or procedures which, if not followed strictly, could result in machinery damage.



This symbol is used to communicate technical information of particular interest.



2. Safety instructions

■ Introduction

The machine must only be operated, maintained and repaired by competent persons who are familiar with machine specifications and operation and aware of safety regulations for preventing accidents.

The operator must imperatively respect safety instructions in this manual and in the warnings posted on the machine. The operator is also obliged to respect current legislation concerning accident prevention, work safety and public traffic circulation.

Designated use of the machine also means following operation, maintenance and repair recommendations given by the manufacturer, and using only genuine spare parts, equipment and accessories, as recommended by the manufacturer.

The manufacturer is not held liable for any damage resulting from machine applications other than those specified by the manufacturer. Any use other than the designated operation is at the risk and responsibility of the operator.

The manufacturer is not held liable for any damage or accidents resulting from machine modifications carried out by the operator himself or by a third party without previous written agreement from the manufacturer.

■ Read and follow the safety instructions

Before using the machine, carefully read all the safety instructions in this manual and the warnings placed on the machine.

Before starting work, the operator must be familiar with all machine controls, handling devices and their functions. It is too late to learn once work has been started!

Never let anyone operate the machine who is not trained to do so.

Should you have any difficulties in understanding certain parts in this manual, please contact your John Deere dealer.



■ Precautions to be taken before carrying out any operations on the machine

Before leaving the tractor or before adjusting, maintaining or repairing the machine, disengage the PTO drive, turn off the engine, remove ignition key and wait until all moving parts have come to a complete stop.

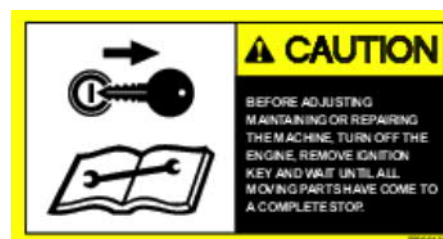

Thank you so much for reading.
Please click the “Buy Now!”
button below to download the
complete manual.



After you pay.

You can download the most
perfect and complete manual in
the world immediately.

Our support email:

ebooklibonline@outlook.com