

FENDT 5250 L from serial No. 258110025

FENDT 5250 L AL from serial No. 268110037

FENDT 6250 L from serial No. 564210009

FENDT 6270 L from serial No. 318210041

FENDT 6270 L AL from serial No. 565810001

**ORIGINAL
OPERATOR'S MANUAL**

FENDT

TABLE OF CONTENTS

- 1. General Information**
- 2. Operation**
- 3. Controls and Instruments**
- 4. Field Operations**
- 5. Lubrication and Maintenance**
- 6. Adjustments**
- 7. Systems**
- 8. Troubleshooting**
- 9. Off-Season Storage**
- 10. Optional Equipment**
- 11. Technical Specifications**
- 12. Alphabetical Index**

CONTENTS

	Section-Page
1. GENERAL INFORMATION	
Customer information	1-1
Appropriate use of the combine	1-3
Combine identification	1-4
Ecology: information for the prevention of environmental pollution	1-10
Safety	1-11
Emergency exit	1-33
Safety devices	1-34
Noise level in the cab	1-42
Fire resistance inside the cab	1-42
Statutory regulations	1-42
Vibrations in the cab	1-43
Hydraulic systems: hoses	1-43
Scrapping and disposal	1-44
Electromagnetic emissions	1-44
Notes for road transport	1-45
Weight distribution	1-47
2. OPERATION	
Crop processing	2-1
3. CONTROLS AND INSTRUMENTS	
Steering column and control pedals	3-1
Multifunction lever	3-2
Front control panel	3-4
Rear control panel (L models)	3-6
Rear control panel (L AL models)	3-8
Agritronicplus	3-18
Cab	3-41
Access to combine components	3-48
Engine: starting	3-51
Stopping the engine	3-53
Driving the combine	3-54
Operations to be carried out before road transport	3-54
Before using the combine	3-56
Towing the combine	3-56
4. FIELD OPERATIONS	
General Information	4-1
Starting and Stopping the Combine	4-2
Cutting table	4-3
Main Crop Elevator	4-11
Cylinder Housing	4-15
Concave	4-16
Rear beater	4-21
Multi Crop Separator	4-22
Straw walkers	4-24
Main Grain Pan	4-25
Fanning mill	4-28
Top sieve	4-29
Bottom sieve	4-30
Returns	4-31
Grain tank	4-32

CONTENTS

	Section-Page
5. LUBRICATION AND MAINTENANCE	
General information	5-1
Preliminary Service Inspection	5-2
Scheduled Service Inspection	5-3
Where and When to Carry Out Service Inspection	5-4
Routine Service Inspection	5-8
Scheduled Service Inspection	5-10
Capacities and specifications (5250 L - 5250 L AL - 6250 L)	5-33
Capacities and specifications (6270 L)	5-37
6. ADJUSTMENTS	
Belt and chain adjustment	6-1
Belts and chains (left-hand side)	6-2
Belts and chains (right-hand side)	6-11
Slip clutches	6-17
Tyres	6-19
Brakes	6-23
Rear axle	6-24
7. SYSTEMS	
Engine	7-1
Hydraulic system	7-6
Hydrostatic transmission system	7-13
Electrical System	7-15
8. TROUBLESHOOTING	
Feeding	8-1
Threshing	8-2
Separation and cleaning	8-4
Hydrostatic Transmission	8-7
Engine (all models)	8-8
Hydraulic system	8-19
Levelling Hydraulics System	8-20
Electrical System	8-20
Straw Chopper	8-21
9. OFF-SEASON STORAGE	
10. OPTIONAL EQUIPMENT	
11. TECHNICAL SPECIFICATIONS	
Wheels and tyres	11-1
Combine Dimensions with Tyres (mm)	11-4
Tracks with runners	11-6
Combine dimensions with tracks (mm)	11-7
Clearance between unloading auger and table (mm)	11-8
Available tables and weights	11-8
Clearance between unloading auger and ground (mm)	11-9
Technical specifications - L models	11-10
Technical specifications - L AL models	11-16
12. ALPHABETICAL INDEX	

1. GENERAL INFORMATION

1.1 CUSTOMER INFORMATION

INTRODUCTION

Your new self-propelled combine is manufactured for harvesting seed and cereal crops, for threshing, separating, cleaning and conveying the grain into the tank and depositing the straw on the ground.

This Operator's Manual contains all the necessary practical information on the operation, adjustment and maintenance of your new machine and should be used as a practical reference guide.

The combine is designed and built to ensure optimum performance, comfort and ease-of-operation in a wide variety of crops and conditions.

The combine has been thoroughly inspected prior to delivery both at the factory and by your Dealer, to ensure you receive it in perfect condition.

To keep the combine in perfect condition and to ensure trouble-free performance, the periodical maintenance operations listed in this manual should be carried out at the recommended intervals.

Before operating or driving the combine, read this Operator's Manual carefully, paying particular attention to the section on safety rules. Always keep this manual on hand for further reference.

The terms "left" and "right" are always used with reference to the travelling direction.

Should you require further information about the machine, please do not hesitate to contact your authorised Dealer. Your Dealer provides specially trained personnel, genuine quality spare parts and the required tools to solve any problems that may arise.

NOTE:

- *This combine has been designed and built in compliance with the Machine Directive 2006/42/EC. A CE Declaration of Conformity is supplied with the machine (see facsimile on page 1-9). The manufacturer disclaims all liability to any claim resulting from unauthorised modification or alteration.*
- *This manual is published for world wide distribution, and the availability of equipment shown as basic or accessory varies according to the territory in which the combine is to be used. Specifications may differ from those contained in this Operator's Manual according to the customer's requirements.*
- *In order to provide a better view, certain illustrations in this manual may show an assembly with standard guards, or the guards required by law in different countries, open or removed. **However, a machine should never be operated in this condition. For your own safety, always ensure all safety guards are closed and correctly fitted before operating the machine.***
- *This Operator's Manual, along with the Operator's Manual for table and PTO shaft, must always be kept in the pocket provided on the right-hand side of the operator seat for convenient reference.*

Modifications and improvements

In accordance with the Company's policy of continuous improvements to its products, the Company reserves the right to modify and improve its products whenever necessary and to the required extent, without any obligation to apply such modifications to previously sold products.

1.2 APPROPRIATE USE OF THE COMBINE

The combines in this series are designed as self-propelled units with a diesel engine.

The machines are manufactured exclusively for usual agricultural purposes, i.e. for harvesting cereal, seed, rice, maize, soya, etc. by cutting or picking-up the crop, threshing and separating the grains from the ears, delivering the grains in the grain tank and unloading them into the grain wagon.

When operating the machine, make sure the cab doors are shut. The operator and instructor, if present, must remain seated in their respective seats with their seatbelts fastened (the operator should not drive the machine when standing).

The machines may be operated only by skilled personnel, who are thoroughly familiar with all machine functions and their operation.

Machine stability is ensured on the following inclinations, on condition that the ground is firm and the tyres offer sufficient grip:

- 25% (15 °) longitudinally (uphill and downhill).
- 30% (18 °) crosswise.

5250 L, 6250 L and 6270 L models

The above combine models are designed for working on level ground to ensure even distribution of the crop inside the machine. **These models HAVE NOT been developed for working on hilly ground.**

5250 L AL and 6270 L AL models

AL models have been expressly designed for harvesting crops in hilly and heavy conditions. The combine body remains perfectly horizontal up to inclinations of 20% crosswise and 8% longitudinally.

General notes on use



WARNING: *The combine may be transported on public roads only with an empty grain tank.*



DANGER: *Correct management of the machine, both during road transport and during field work, requires an operator to be sitting in the operator seat (the operator is not allowed to drive the machine standing).*



WARNING: *Operators should not use alcohol or drugs which can effect their alertness or coordination when operating the combine. Operators on prescription or over-the-counter drugs need a doctor's note to certify that they can operate the combine properly.*

TABLE TYPES

Combines in this series may use 4.80, 5.40, 6.00, 6.60 or 7.60 m cutting tables.

In this manual, the term “table/s” signifies both the cutting table and the maize header when used generically. The term “cutting table” refers to the assembly consisting of reel, cutting bar, table auger, etc. used to harvest cereal, rice, soya, etc. The term “maize header” refers to the equipment formed by stalk grippers, stripping blades, conveyor chains, etc. used for maize harvesting.

1.3 COMBINE IDENTIFICATION

The combine and its main components are identified by serial numbers and/or production codes.

The position of the different identification data is described below.

NOTE: Always quote the combine serial number in any communication to your Dealer.

Combine type plate

Fig. 1 – Fig. 4

The manufacturer's type plate (1), statutory for all countries (or (2), for France only), is positioned on the outer right-hand side of the operator platform and shows the following information:

- Combine type.
- Approval number.
- Combine serial number.
- Weight (on both axes).
- Towing weight.

For further details, please refer to the type approval certificate.

The safety plate (3) is located next to the approval plate, and guarantees that the combine was built in compliance with Machinery Directive Directive 2006/42/EC as well as Directive 2004/108/EC.

This plate shows the following information:

- Manufacturing year.
- Model.
- Combine serial number.
- Crop type.
- Total weight (normal configuration).
- Maximum towing weight.

Maximum vertical load on the trailer hitch.

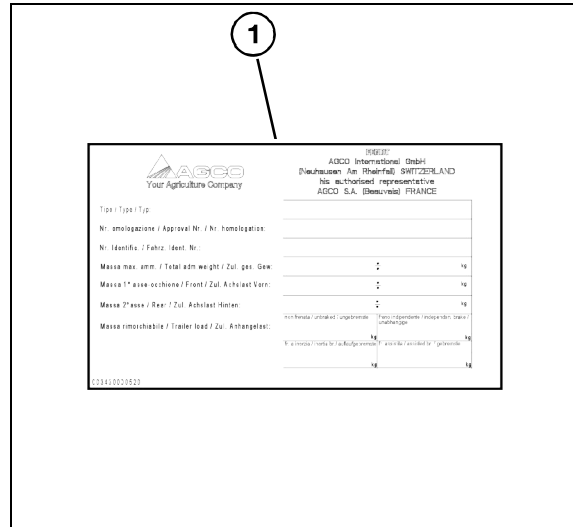

Fig. 1

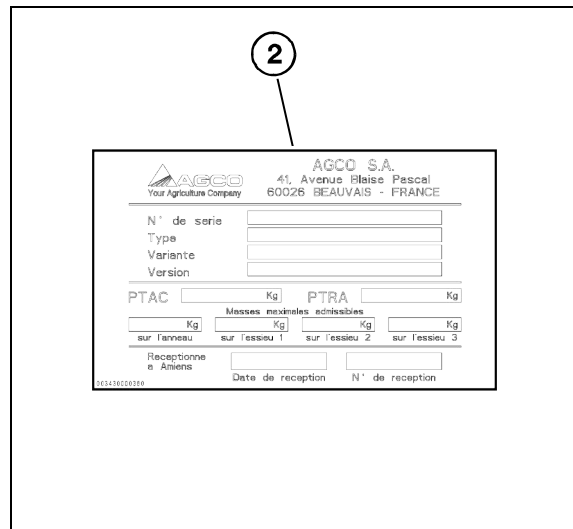

Fig. 2

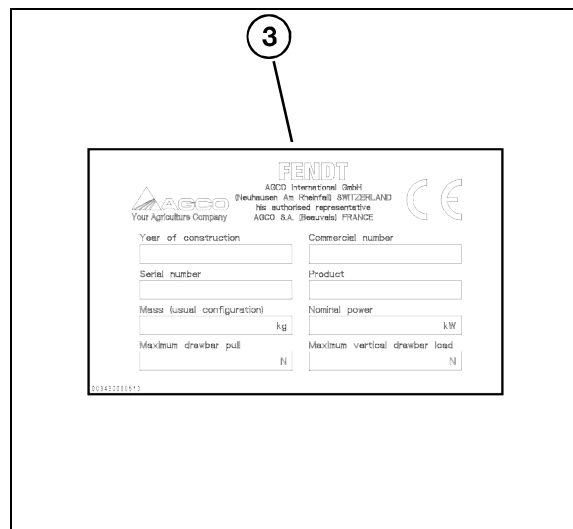

Fig. 3

In certain countries (e.g. Russia) the manufacturer's type plate is positioned next to a decal/plate (4) corresponding to the type approval.

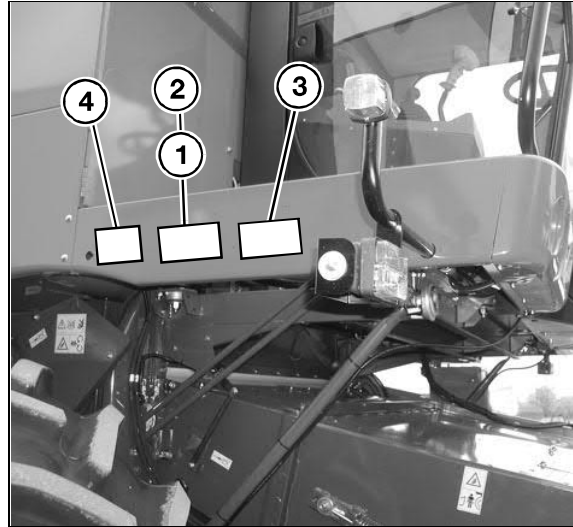

Fig. 4

Combine identification details

Fig. 5

Combine type and serial number appear on the plate and are also punched into the rear right-hand side of the frame (5).

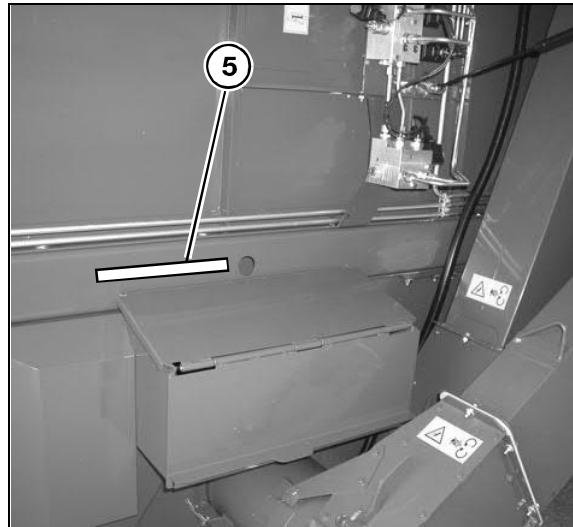

Fig. 5

GENERAL INFORMATION

IVECO NEF engine identification (models 5250 L, 5250 L AL and 6250 L) - Fig. 6

The engine is identified by the plate (1) on the engine cover.

The plate shows:

- Engine range
- Engine type
- Engine serial number
- Type approval number (identifies the compliance with the gas emissions directive)

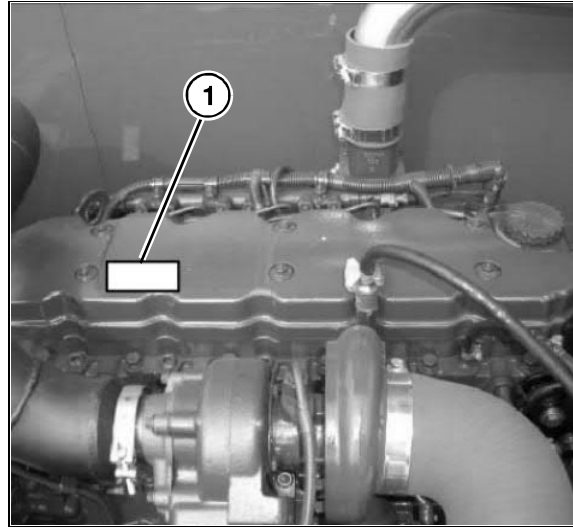

Fig. 6

SisuDiesel engine identification (models 6270 L and 6270 L AL) - Fig. 7

The engine is identified by the plate (1) on the engine block.

The plate shows:

- Engine manufacturer
- Engine type
- Engine power and rated speed
- Engine serial number
- Valve clearance
- Injection timing
- Idling speed
- Compliance with various EC directives
- Name of the engine assembler.

The engine serial number is always stamped on the cylinder block in the areas marked by the arrows.

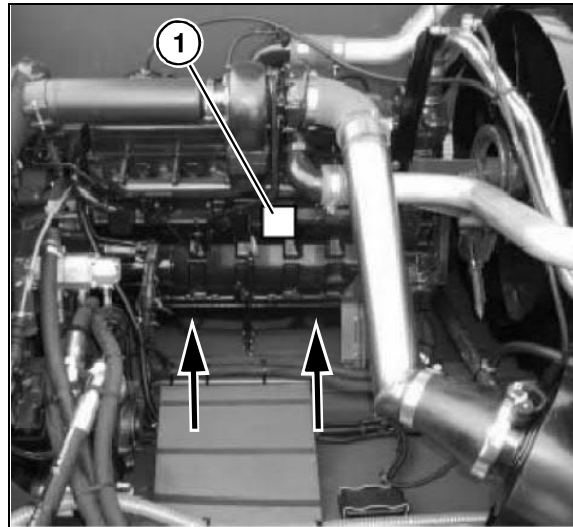

Fig. 7

Cutting table identification

Fig. 8

The type and serial number are stamped on the type plate located on the left-hand side of the frame.

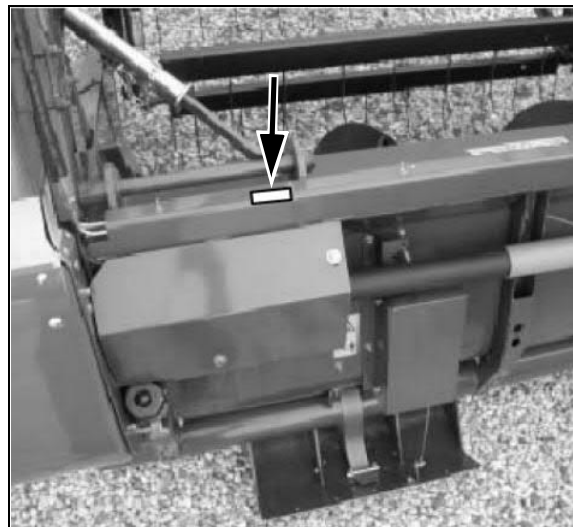

Fig. 8

Cab identification

Fig. 9

The cab identification plate is fixed to the floor in the area between the fuse boxes and the cab access door.

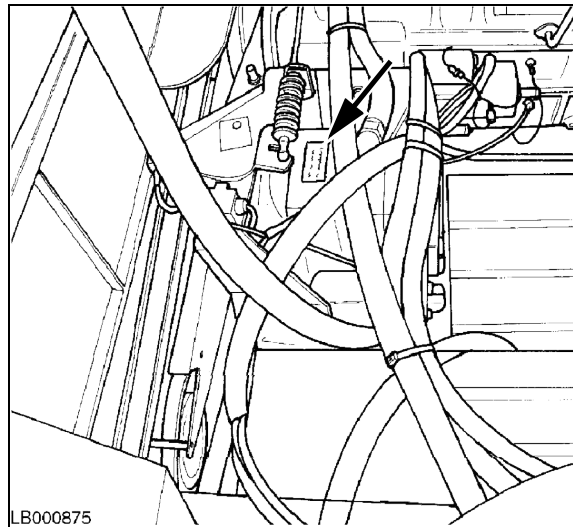

Fig. 9

Hydrostatic pump identification

Fig. 10

The type plate is located on the front part of the pump.



LB000875

Fig. 10

Hydrostatic motor identification

Fig. 11

The type plate is located on the lower part of the motor.

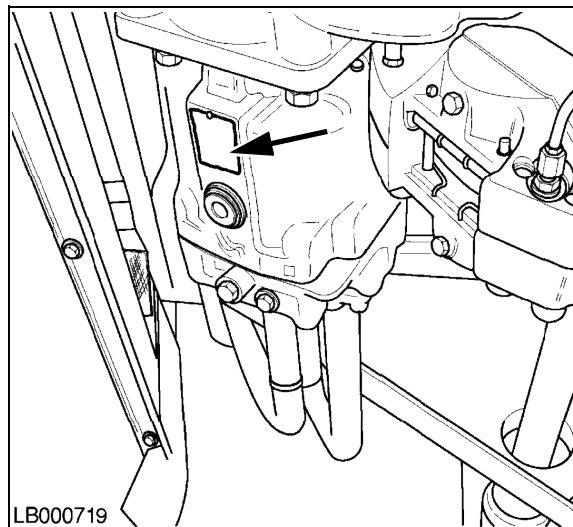

LB000719

Fig. 11

Thank you so much for reading.
Please click the “Buy Now!”
button below to download the
complete manual.



After you pay.

You can download the most
perfect and complete manual in
the world immediately.

Our support email:

ebooklibonline@outlook.com