

***FENDT 5180 E*** from serial No. 551110001

**OPERATOR'S MANUAL**



# **TABLE OF CONTENTS**

- 1. General Information**
- 2. Operation - Controls and Instruments**
- 3. Field Operations**
- 4. Lubrication and Maintenance**
- 5. Adjustments**
- 6. Troubleshooting**
- 7. Off-season storage**
- 8. Optional Equipment**
- 9. Technical Specifications**
- 10. Alphabetical Index**

# TABLE OF CONTENTS

	Section-Page
<b>1. GENERAL INFORMATION</b>	
Customer information .....	1-1
Combine identification .....	1-3
Ecology: information for the prevention of environmental pollution .....	1-8
Safety .....	1-9
Emergency exit .....	1-30
Safety devices .....	1-31
Appropriate use .....	1-37
Noise level in the cab .....	1-38
Fire resistance inside the cab .....	1-38
Statutory regulations .....	1-38
Vibrations in the cab .....	1-39
Hydraulic systems: hoses .....	1-39
Safety requirements for hydraulic systems and components (European standard EN 982) . . .	1-39
Scrapping and disposal .....	1-40
Electromagnetic emissions .....	1-40
Notes for road transport .....	1-41
Weight distribution .....	1-43
<b>2. OPERATION - CONTROLS AND INSTRUMENTS</b>	
Operation - Crop Processing .....	2-1
Steering column and control pedals .....	2-6
Multifunction lever .....	2-7
Front control panel .....	2-8
Rear control panel .....	2-9
Controls at the operator seat .....	2-18
Access to combine components .....	2-25
Starting the engine .....	2-28
Stopping the engine .....	2-29
Driving the combine .....	2-30
Operations to be carried out before road transport .....	2-31
Before Using the Combine .....	2-33
Towing the combine .....	2-34
<b>3. FIELD OPERATIONS</b>	
General Information .....	3-1
Starting and Stopping the Combine .....	3-2
Cutting table .....	3-3
Main Crop Elevator .....	3-6
Cylinder housing .....	3-10
Concave .....	3-11
Rear beater .....	3-16
Straw walkers .....	3-17
Main Grain Pan .....	3-18
Fanning mill .....	3-19
Top sieve .....	3-21
Bottom sieve .....	3-22
Returns .....	3-23
Grain tank .....	3-24
<b>4. LUBRICATION AND MAINTENANCE</b>	
General information .....	4-1
Preliminary Service Inspection .....	4-2
Scheduled Service Inspection .....	4-3
Where and When to Carry Out Service Inspection .....	4-4
Routine Service Inspection .....	4-6
Maintenance work .....	4-8
Capacities and Specifications - FENDT 5180 E .....	4-28

Service Schedule .....	4-29
------------------------	------

## 5. ADJUSTMENTS

Belt and chain adjustment .....	5-1
Belts and chains (left-hand side) .....	5-2
Belts and chains (right-hand side) .....	5-9
Slip clutches .....	5-15
Tyres .....	5-16
Brakes .....	5-20
Rear axle .....	5-21
Engine .....	5-23
Hydraulic system .....	5-26
Electrical system .....	5-29

## 6. TROUBLESHOOTING

Feeding .....	6-1
Threshing unit .....	6-1
Separation and cleaning .....	6-2
Hydrostatic Transmission .....	6-5
Engine .....	6-6
Auxiliary hydraulics .....	6-7
Auxiliary Electrical System .....	6-7
Straw Chopper .....	6-8

## 7. OFF-SEASON STORAGE

## 8. OPTIONAL EQUIPMENT

## 9. TECHNICAL SPECIFICATIONS

Wheels and tyres .....	9-1
Tracks with runners .....	9-3
Combine Dimensions with Tyres (mm) .....	9-4
Combine Dimensions with Half-Tracks (mm) .....	9-5
Clearance between unloading auger and table .....	9-6
Available tables and weights .....	9-6
Clearance between unloading auger and ground .....	9-7
Technical specifications - 5180 E model .....	9-8

## 10. ALPHABETICAL INDEX

# 1. GENERAL INFORMATION

## 1.1 CUSTOMER INFORMATION

### INTRODUCTION

Your new self-propelled combine is manufactured for harvesting seed and cereal crops, for threshing, separating, cleaning and conveying the grain into the tank and depositing the straw on the ground.

This Operator's Manual contains all the necessary practical information which describes the operation, adjustment and maintenance of your new machine and should be used as a practical reference guide.

The combine is designed and built to ensure optimum performance, comfort and ease of operation in a wide variety of crops and conditions.

The combine has been thoroughly inspected prior to delivery both at the factory and by your Dealer, to ensure you receive it in perfect condition.

To keep the combine in perfect condition and to ensure trouble-free performance, the periodical maintenance operations listed in this manual should be carried out at the recommended intervals.

**Before operating or driving the combine, read this Operator's Manual carefully, paying particular attention to the section on safety rules. Always keep this manual on hand for further reference.**

The terms "left" and "right" are always used with reference to the travelling direction.

Should you require further information about the machine, please do not hesitate to contact your authorised Dealer. Your Dealer provides specially trained personnel, genuine spare parts and the required tools to solve any problems that may arise.

### NOTE:

- This combine has been designed and built in compliance with the Machine Directive 98/37/EC. A CE Declaration of Conformity is supplied with the machine. The manufacturer disclaims all liability to any claim resulting from unauthorised modification or alteration.
- This manual is published for world wide distribution, and the availability of equipment shown as basic or accessory varies according to the territory in which the combine is to be used. Specifications may differ from those contained in this Operator's Manual according to the customer's requirements.
- In order to provide a better view, certain illustrations in this manual may show an assembly with standard guards, or the guards required by law in different countries, open or removed. **However, a machine should never be operated in this condition. For your own safety, always ensure all safety guards are fitted and closed correctly before operating the machine.**
- **This Operator's Manual, along with the Operator's Manual for the table, must always be kept in the pocket provided on the right-hand side of the operator seat for convenient reference.**

### Modifications and improvements

In accordance with the Company's policy of continuous improvements to its products, the Company reserves the right to modify and improve its products whenever necessary and to the required extent, without any obligation to apply such modifications to previously sold products.



## GENERAL INFORMATION

### Engine identification - Fig. 4

The engine is identified by the plate (1) on the engine flywheel housing.

The plate shows:

- Family.
- Type.
- Serial number.
- Type approval number (identifies the compliance with the gas emissions directive).

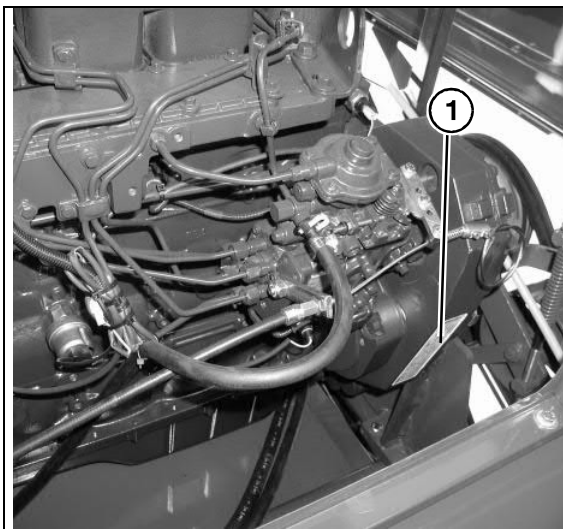

Fig. 4

### Straw chopper identification (if fitted) - Fig. 5

The type plate is located on the right-hand side next to the straw chopper rotor support.

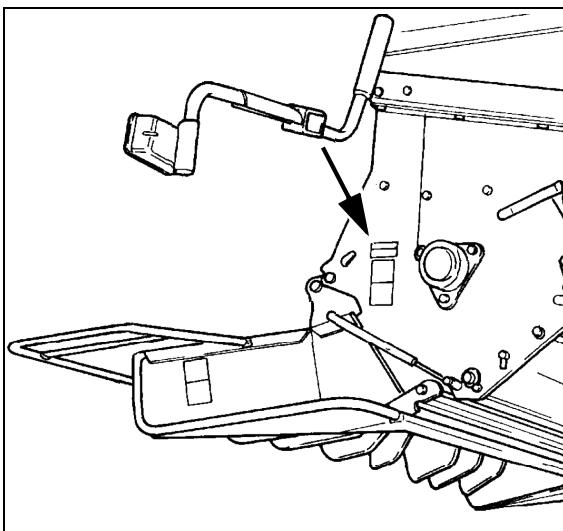

Fig. 5

### Cutting table identification details - Fig. 6

The type and serial number are stamped on the type plate located on the left-hand side of the frame.

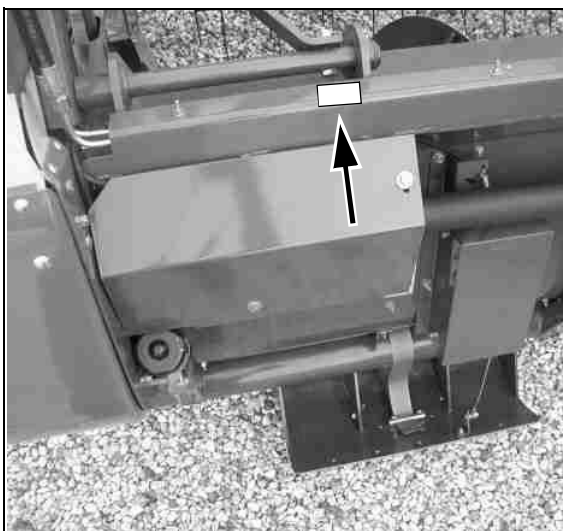

Fig. 6

**Cab identification - Fig. 7**

The cab type plate is located in the bottom left corner of the operator seat, under the concave opening levers.

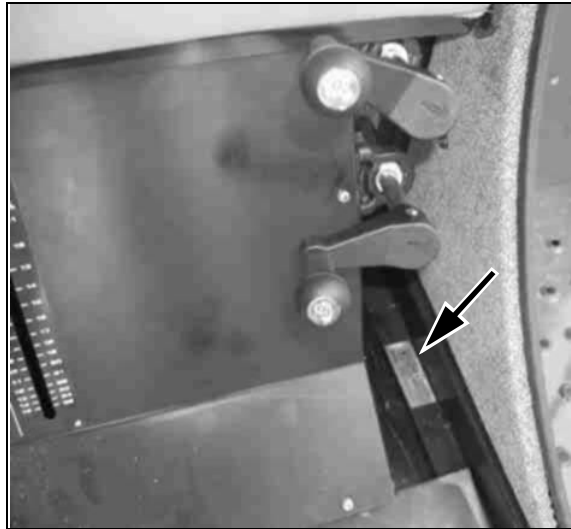

Fig. 7

**Hydrostatic pump identification**

Fig. 8

The type plate is located on the front part of the pump.

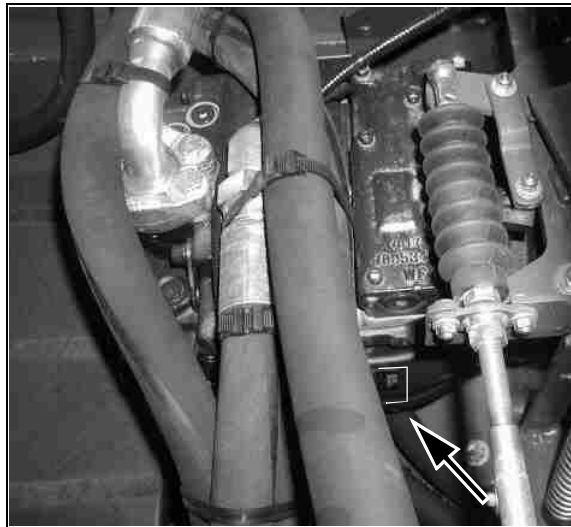
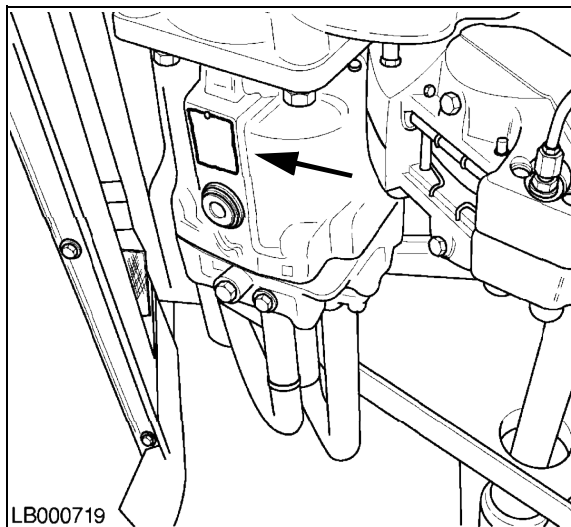

Fig. 8

**Hydrostatic motor identification**

Fig. 9

The type plate is located on the lower part of the motor.



LB000719

Fig. 9



## GENERAL INFORMATION

---

### Chaff spreader identification (if fitted) - Fig. 10

The type plate is located on the right-hand side next to the chaff spreader adjustment lever.

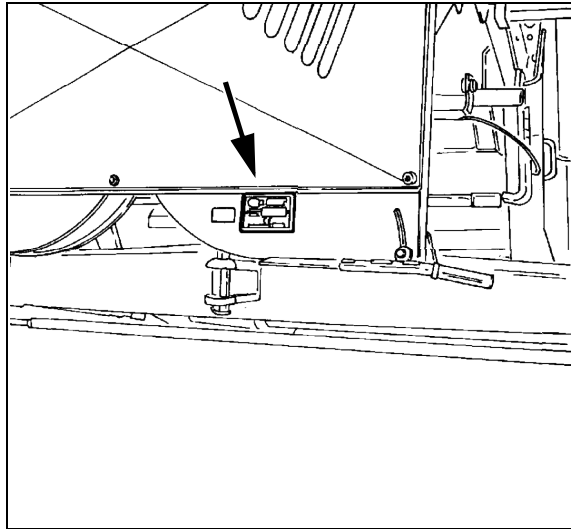

Fig. 10

### Rockinger trailer hitch identification (if fitted) - Fig. 11

The plate is positioned on the top part of the Rockinger trailer hitch.

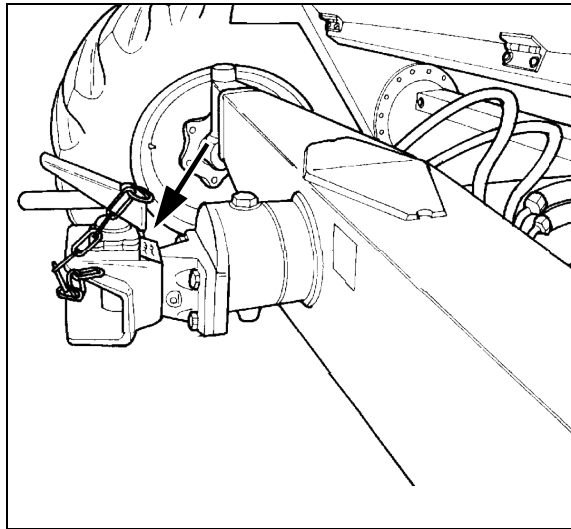

Fig. 11

**Please enter the identification details of your combine for convenient reference:**

Combine model. ....

Combine serial number. ....

Engine type and serial number. ....

Cab serial number. ....

Straw chopper serial number. ....

Cutting table serial number. ....

Date of initial startup. ....

Dealer's telephone number. ....

**TABLE TYPES**

5180 combines can be equipped with a 420, 480, 540, 600, 660 or 760 cm cutting table.

**NOTE:** *In this manual, the term "table/s" signifies both the cutting table and the maize header when used generically. The term "cutting table" refers to the assembly consisting of reel, cutting bar, table auger, etc. used to harvest cereal, rice, soya, etc. The term "maize header" refers to the assembly consisting of stalk grippers, stripping blades, conveyor chains, etc. used for harvesting maize.*

## **1.3 ECOLOGY: INFORMATION FOR THE PREVENTION OF ENVIRONMENTAL POLLUTION**

Soil, air and water are essential to agriculture and to all life on earth. **PROTECT THEM.** In areas where no local regulations impose standards for the use and disposal of chemicals and petrochemical products required by modern technology, all necessary precautions must be adopted to avoid any risk of pollution.

The following guidelines may be helpful:

- Find out about the legal requirements in your country and comply strictly with them.
- If no regulations are in force, ask your Dealer about the effects of lubricants, fuels, antifreeze mixtures, cleaners, etc. on people and environment; also ask how to store, use and dispose of such products correctly. In most cases, agricultural advisers will be able to answer your questions satisfactorily.

### **Instructions:**

- 1.) When refuelling the machine, take all necessary precautions to avoid fuel spillage. In particular, avoid using pressurised containers or fuel supply systems, as these are unsuitable.
- 2.) As a rule, avoid any skin contact with liquid fuels, lubricants, acids, solvents, etc. Many of these products contain substances which are potentially injurious to health.
- 3.) **Do not dispose of lubricants by burning (they contain substances which may evolve gases injurious to health).**
- 4.) Whenever possible, use biodegradable oil for lubricating the chains, as this oil cannot be collected.  
In many countries, biodegradable rape oil and other vegetable lubricants are available on the market.
- 5.) Avoid spillage while draining oil, brake fluid, coolant etc. from the engine, gearbox and hydraulic system. Collect the fluids in suitable containers and dispose of them properly, according to regulations in force.
- 6.) Modern coolants and mixtures, e.g. antifreeze and other additives, must be replaced every two years. Never let them drain into the ground; collect and dispose of them safely.
- 7.) Never open or modify the air-conditioning system. It contains gases which must not be released in the atmosphere. Contact your Dealer or a specialist who has the correct equipment for emptying and recharging the system and for carrying out any required maintenance or repair.
- 8.) Immediately repair any leaks or defects in the engine cooling or hydraulic system to prevent any risk of pollution.
- 9.) Never increase the pressure in a pressurised system. This may cause the components to burst.
- 10.) When welding, protect the hoses properly against welding spatters that could damage or weaken hoses and sleeves, resulting in oil and coolant leaks.

Thank you so much for reading.  
Please click the “Buy Now!”  
button below to download the  
complete manual.



After you pay.

You can download the most  
perfect and complete manual in  
the world immediately.

Our support email:

[ebooklibonline@outlook.com](mailto:ebooklibonline@outlook.com)