

**5220 E** *from serial no. 551600298*

**ORIGINAL  
OPERATOR'S MANUAL**

**FENDT**

# **TABLE OF CONTENTS**

- 1. General Information**
- 2. Operation**
- 3. Controls and Instruments**
- 4. Field Operations**
- 5. Lubrication and Maintenance**
- 6. Adjustments**
- 7. Systems**
- 8. Troubleshooting**
- 9. Off-Season Storage**
- 10. Optional Equipment**
- 11. Technical Specifications**
- 12. Alphabetical Index**

# CONTENTS

	Section-page
<b>1. GENERAL INFORMATION</b>	
Customer information .....	1-1
Appropriate use .....	1-3
Combine identification .....	1-4
Ecology: information for the prevention of environmental pollution .....	1-9
Safety .....	1-10
Emergency exit .....	1-31
Safety devices .....	1-32
Machine lifting .....	1-42
Towing the combine .....	1-43
Fire resistance inside the cab .....	1-43
Statutory regulations .....	1-43
Noise level in the cab .....	1-44
Ambient noise in motion Directive 2009/63/EC .....	1-44
Vibrations in the cab .....	1-44
Hydraulic systems: hoses .....	1-45
Safety requirements for hydraulic systems and components .....	1-45
Scrapping and disposal .....	1-46
Electromagnetic emissions .....	1-46
Notes for road transport .....	1-47
Weight distribution .....	1-49
<b>2. OPERATION</b>	
Operation - Crop Processing .....	2-1
<b>3. CONTROLS AND INSTRUMENTS</b>	
Steering column and control pedals .....	3-1
Multifunction lever .....	3-2
Front control panel .....	3-4
Rear control panel .....	3-6
Controls at the operator seat .....	3-14
Agritronicplus .....	3-16
Cab .....	3-38
Access to combine components .....	3-44
Starting the engine .....	3-47
Stopping the engine .....	3-48
Operations to be carried out before road transport .....	3-49
Before Using the Combine .....	3-51
<b>4. FIELD OPERATIONS</b>	
General Information .....	4-1
Starting and Stopping the Combine .....	4-2
Cutting table .....	4-3
Main Crop Elevator .....	4-8
Cylinder housing .....	4-10
Cylinder .....	4-11
Concave .....	4-12
Rear beater .....	4-17
Straw walkers .....	4-18
Main Grain Pan .....	4-19
Fanning mill .....	4-22
Top sieve .....	4-24
Bottom sieve .....	4-25
Returns .....	4-26
Grain tank .....	4-27

# CONTENTS

	Section-page
<b>5. LUBRICATION AND MAINTENANCE</b>	
General information . . . . .	5-1
Preliminary Service Inspection . . . . .	5-2
Scheduled Service Inspection . . . . .	5-3
Where and When to Carry Out Service Inspection . . . . .	5-4
Routine Service Inspection . . . . .	5-6
Scheduled maintenance work . . . . .	5-8
Periodical maintenance operations . . . . .	5-34
Capacities and specifications - 5220 E . . . . .	5-37
<b>6. ADJUSTMENTS</b>	
Belt and chain adjustment . . . . .	6-1
Belts and chains (left-hand side) . . . . .	6-2
Belts and chains (right-hand side) . . . . .	6-11
Slip clutches . . . . .	6-17
Tyres . . . . .	6-18
Parking . . . . .	6-22
Rear axle . . . . .	6-23
Electrical system . . . . .	6-26
<b>7. SYSTEMS</b>	
Engine supply system . . . . .	7-2
Engine intake and exhaust system . . . . .	7-5
Engine cooling system . . . . .	7-6
Engine lubrication system . . . . .	7-7
SCR system . . . . .	7-8
Hydraulic system . . . . .	7-10
Hydrostatic transmission system . . . . .	7-15
Electrical System . . . . .	7-17
<b>8. TROUBLESHOOTING</b>	
Feeding . . . . .	8-1
Threshing unit . . . . .	8-1
Separation and cleaning . . . . .	8-2
Hydrostatic Transmission . . . . .	8-6
Engine . . . . .	8-6
Auxiliary hydraulics . . . . .	8-9
Auxiliary Electrical System . . . . .	8-9
Straw Chopper . . . . .	8-10
<b>9. OFF-SEASON STORAGE</b>	
<b>10. OPTIONAL EQUIPMENT</b>	
<b>11. TECHNICAL SPECIFICATIONS</b>	
Wheels and tyres . . . . .	11-1
Combine Dimensions with Tyres (mm) . . . . .	11-3
Combine Dimensions with Half-Tracks (mm) . . . . .	11-4
Tracks with runners . . . . .	11-5
Clearance between unloading auger and table . . . . .	11-6
Available tables and weights . . . . .	11-6
Clearance between unloading auger and ground . . . . .	11-7
Technical data - models 5220 E . . . . .	11-8
<b>12. ALPHABETICAL INDEX</b>	

# 1. GENERAL INFORMATION

## 1.1 CUSTOMER INFORMATION

### INTRODUCTION

Your new self-propelled combine is manufactured for harvesting seed and cereal crops, for threshing, separating, cleaning and conveying the grain into the tank and depositing the straw on the ground.

This Operator's Manual should be used as a practical reference guide: It contains all the necessary practical information for the operation, adjustment and maintenance of your new machine.

Your combine was designed and built to ensure optimum performance, comfort and ease-of-operation in a wide variety of crops and conditions.

The combine has been thoroughly inspected prior to delivery both at the factory and by your Dealer, to ensure you receive it in perfect condition.

To keep the combine in perfect condition and to ensure trouble-free performance, the periodical maintenance operations listed in this manual should be carried out at the recommended intervals.

**Before operating and/or driving the combine, read this Operator's Manual carefully, paying particular attention to the section on safety rules.**

**Always keep this manual on hand for further reference.**

The terms "left" and "right" are always used with reference to the machine travelling direction.

Should you require further information about the machine, please do not hesitate to contact your authorised Dealer.

Your Dealer provides specially trained personnel, genuine spare parts and the required tools to solve any problems that may arise.

### NOTE:

- *This combine has been designed and built in compliance with the Machine Directive 2006/42/EC. An EC Declaration of Conformity is supplied with the machine (see facsimile on page 1-8).*
- *This manual is published for worldwide distribution, and the availability of equipment shown as standard or optional varies according to the territory in which the combine is to be used. Specifications may differ from those contained in this Operator's Manual according to the customer's requirements.*
- *In order to provide a better view of features or adjustments, certain illustrations in this manual may show an assembly with standard guards, or the guards required by law in different countries, open or removed. **However, a machine should never be operated in this condition. For your own safety, always ensure all safety guards are fitted and closed correctly before operating the machine.***
- *This Operator's Manual, along with the Operator's Manuals for the table and PTO shaft, must always be kept in the compartment under the operator's seat for storage and convenient reference.*

### Company policy

In accordance with the Company's policy of continuous improvements to its products, the Company reserves the right to modify and improve its products whenever necessary and to the required extent, without any obligation to apply such modifications to previously sold products. The information contained in this Manual refers to the current situation at the time it was written. All the data given may vary.

## **1.2 APPROPRIATE USE**

These combines are designed as self-propelled units with a diesel engine.

The machines are manufactured exclusively for usual agricultural purposes, i.e. for harvesting cereal, seed, rice, maize, soya, etc. by cutting or picking-up the crop, threshing and separating the grains from the ears, delivering the grains in the grain tank and unloading them into the grain wagon.

When operating the machine, make sure the cab doors are shut. The operator and instructor, if present, must remain seated in their respective seats with their seatbelts fastened (the operator should not drive the machine when standing).

The machines may be operated only by skilled personnel, who are thoroughly familiar with all the machine's functions and harvesting techniques.

Machine stability is ensured on the following inclinations, on condition that the ground is firm and the tyres offer sufficient grip:

30% (18 °) longitudinally (uphill and downhill).

30% (18 °) crosswise.

These machines are designed for working on level ground to ensure even distribution of the crop inside the machine. **These models HAVE NOT been developed for working on sloping ground.**

### **Forbidden uses**

Do not use the machine for tasks or purposes other than those specified in this Manual, on the safety decals or on other safety information provided with the machine.

The following pages contain recommendations on correct and incorrect use of the machine when travelling on public roads, during field operations and during maintenance.

### **TABLE TYPES**

5220 E combines can be equipped with a 420, 480, 540, 600, 660 or 760 cm cutting table.

**NOTE:** *In this manual, the term “table/s” signifies both the cutting table and the maize header when used generically. The term “cutting table” refers to the assembly consisting of reel, cutting bar, table auger, etc. used to harvest cereal, rice, soya, etc. The term “maize header” refers to the equipment formed by stalk grippers, stripping blades, conveyor chains, etc. used for maize harvesting.*

## 1.3 COMBINE IDENTIFICATION

The combine and its main components are identified by serial numbers and/or production codes. The position of the different identification data is described below.

**NOTE:** Always quote the combine serial number when contacting your Dealer for spare parts or assistance.

### Combine approval and safety plates - Fig. 1 and Fig. 2

The manufacturer's type plate (1), statutory for all countries, or (2), for France only, is positioned on the outer right-hand side of the operator platform and shows the following information:

- Combine type.
- Approval number.
- Combine serial number.
- Weight (on both axes).
- Towing weight.

For further details, please refer to the type approval certificate.

The safety plate (3) is located next to the approval plate, and guarantees that the combine was built in compliance with Machinery Directive Directive 2006/42/EC as well as Directive 2004/108/EC.

This plate shows the following information:

- Year of manufacture and year of use.
- Model.
- Combine serial number.
- Crop type.
- Total weight (normal configuration).
- Maximum towing weight.
- Maximum vertical load on the trailer hitch.

In certain countries (e.g. Russia) the manufacturer's type plate is positioned next to another plate corresponding to the type approval.

### Combine identification details

Fig. 3

Combine type and serial number appear on the plate and are also punched into the rear right-hand side of the frame (1).

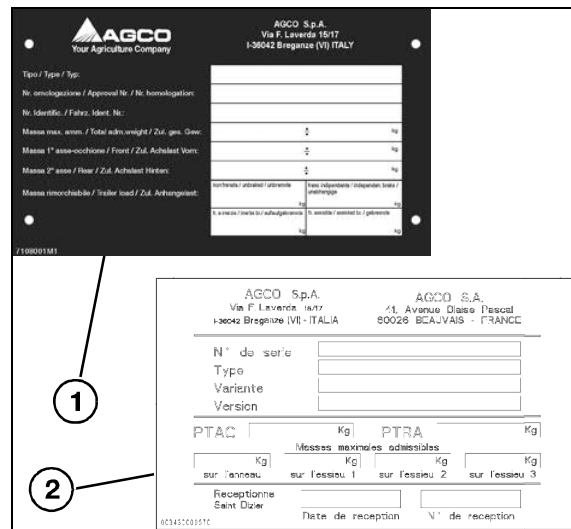

Fig. 1

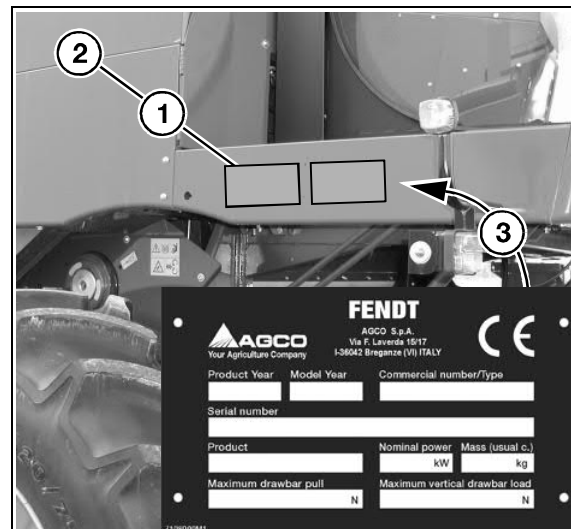

Fig. 2

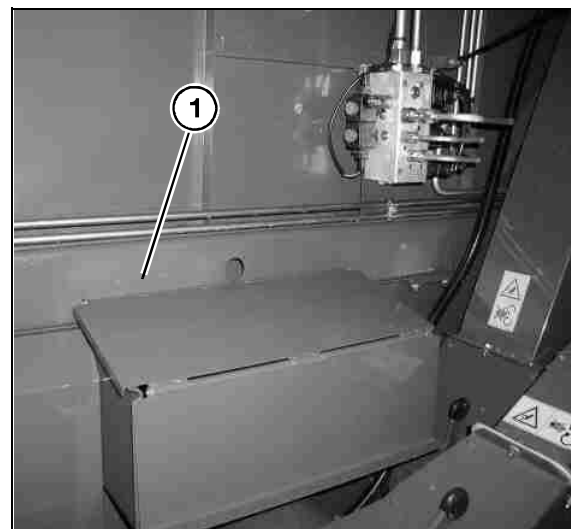

Fig. 3

**Engine identification - Fig. 4**

The engine is identified by the plate (1) stating:

- Engine manufacturer
- Engine type
- Engine power and rated speed
- Engine serial number
- Valve clearance
- Customer reference code
- Idling speed
- Compliance with Directive 97/68/EC
- Name of the engine assembler.

The engine serial number is always also stamped on the cylinder block.

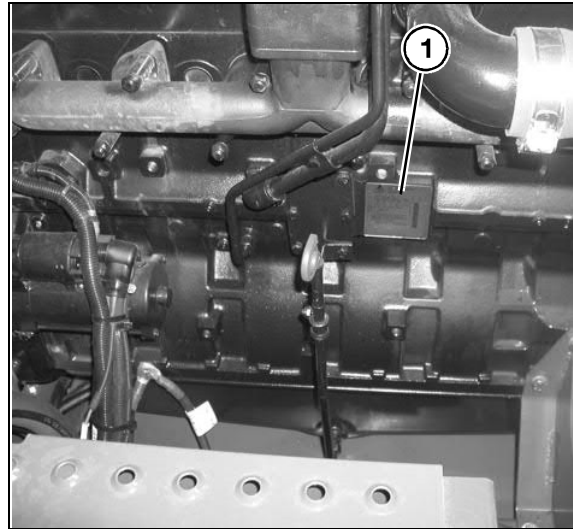

Fig. 4

**Straw chopper identification (if fitted) - Fig. 5**

The type plate is located on the right-hand side next to the straw chopper rotor support.

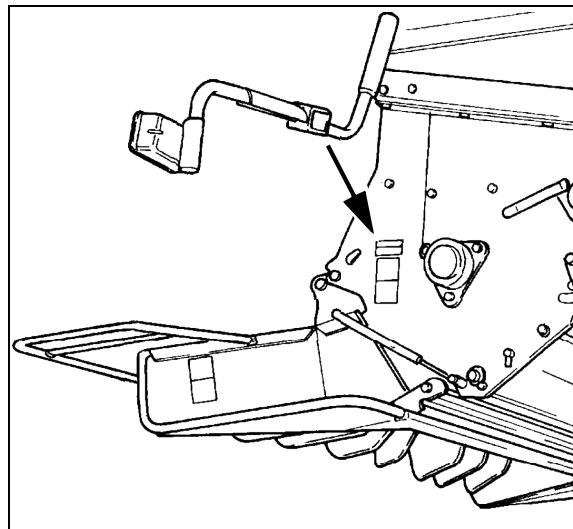

Fig. 5

**Cutting table identification details - Fig. 6**

The type and serial number are stamped on the type plate located on the left-hand side of the frame.

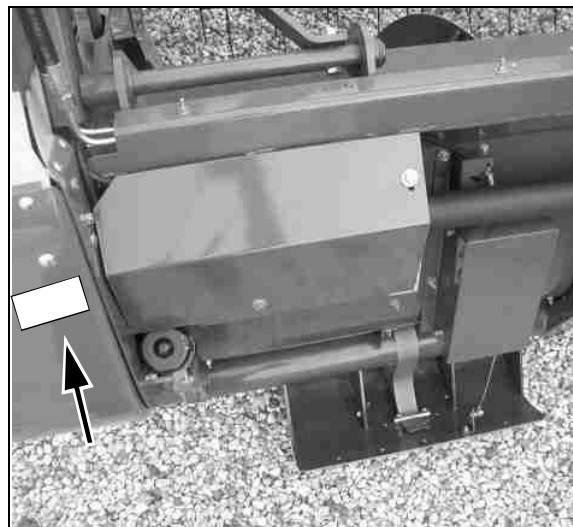

Fig. 6



## **GENERAL INFORMATION**

### **Cab identification**

Fig. 7

The cab identification plate is located on the lower left-hand corner of the driver's seat.

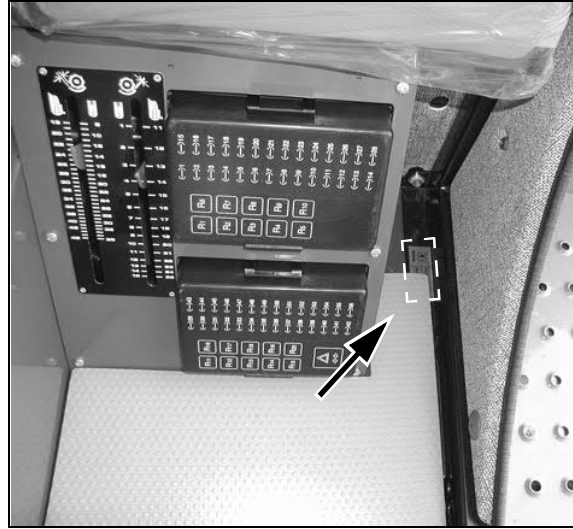

Fig. 7

### **Hydrostatic pump identification**

Fig. 8

The type plate is located on the front part of the pump.

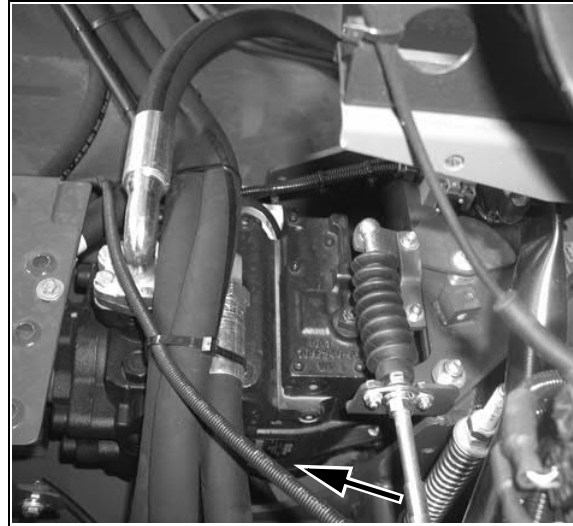

Fig. 8

### **Hydrostatic motor identification**

Fig. 9

The type plate is located on the lower part of the motor.

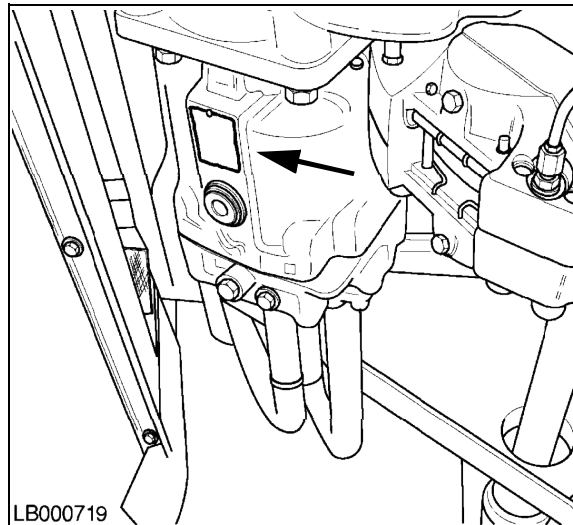

Fig. 9

**Chaff spreader identification (if fitted) - Fig. 10**

The type plate is located on the right-hand side next to the chaff spreader adjustment lever.

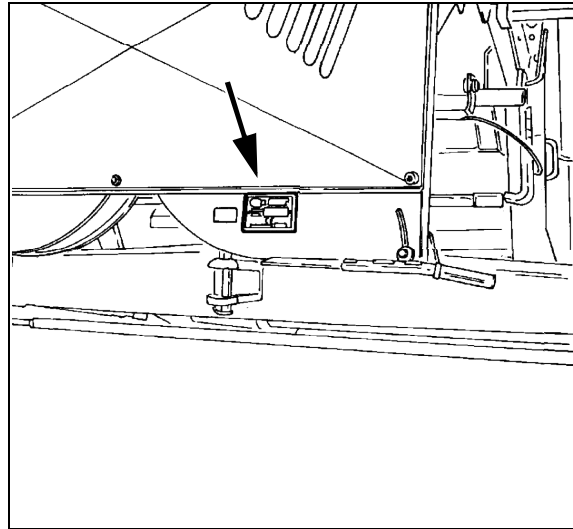

Fig. 10

**Trailer hitch identification (if fitted) - Fig. 11**

The plate is positioned on the right-hand side of the trailer hitch.

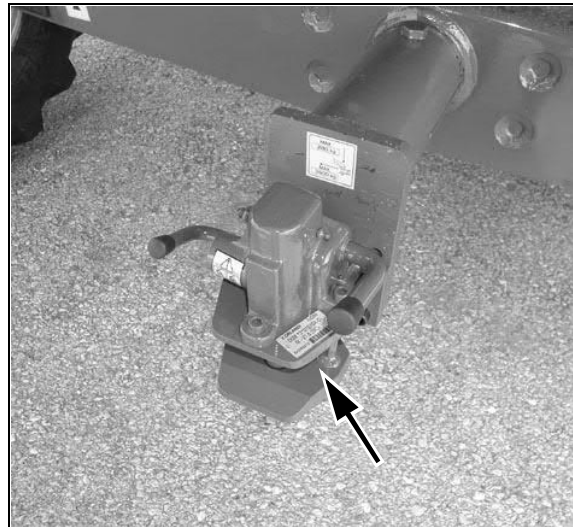

Fig. 11

# GENERAL INFORMATION

Please enter the identification details of your combine for convenient reference:

- Combine model .....
- Combine serial number .....
- Engine type and serial number .....
- Cab serial number .....
- Straw chopper serial number .....
- Cutting table serial number .....
- Date of initial start-up .....
- Dealer's telephone number .....

## EC Declaration of Conformity

The EC Declaration of Conformity, the front and reverse sides of which are shown below, certifies that **the combine was designed and built in compliance with the regulations currently applicable within the European Community.**

The cutting table has its own Declaration of Conformity.

 <p><b>AGCO S.p.A.</b> Via F. Laverda 15/17 36042 Breganze (VI) Italy</p>	<p><b>IT</b> DICHIARAZIONE DI CONFORMITÀ CE IN CONFORMITÀ ALLE DIRETTIVE 2004/42/CE E 2004/170/CE</p> <p>E' IL SUO RAPPRESENTANTE AUTORIZZATO..... 2</p> <p>DECLARA SOTTO LA PROPRIA RESPONSABILITÀ CHE IL MEZZO AGRICOLA CON LA FUNZIONE DI: MULINO..... 3</p> <p>MODELLO..... 4</p> <p>NUMERO COMMERCIALE..... 4</p> <p>NUMERO DI SERIE..... 5</p> <p>IL SOGGETTO DELLA PRESENTE DICHIARAZIONE E' CONFORME ALLA RESPONSABILITÀ DELLA DIRETTIVA 2004/42/CE, MODIFICATA DALLA..... 6</p> <p>E DELLA DIRETTIVA 2004/170/CE..... 7</p> <p>INDICA, MODELLO E FIRMA DELLA PERSONA AUTORIZZATA: 8</p> <p>LUOGO E DATA..... 9</p>	<p><b>FR</b> DECLARATION DE CONFORMITE CE SECON LES DIRECTIVES 2004/42/CE E 2004/170/CE</p> <p>DECLARE, SONS NOMME SEULE RESPONSABLE, QUE LA MACHINE AGRICOLE AVEC POUR FONCTION: MULLINO..... 3</p> <p>MODELE..... 4</p> <p>NUMERO COMMERCIAL..... 4</p> <p>N° DE SERIE..... 5</p> <p>BASANT COLITE DE LA DECLARATION CE CONFORME AVEC RESPONSABILITE DE LA DIRECTIVE 2004/42/CE, MODIFIEE PAR..... 6</p> <p>OBJET DE VUE PRECISPEURS DE LA DIRECTIVE 2004/170/CE AERENDE PAK..... 7</p> <p>NOM, FONCTION ET SIGNATURE DE LA PERSONNE AUTORISEE..... 8</p> <p>LIEN ET DATE..... 9</p>	<p><b>DA</b> EU-ØVERENSSTEMMELSEERKLÆRING I OVERENSSTEMMELSE MED DIREKTIV 2004/42/EF OG 2004/170/EF</p> <p>OG VORES AUTORIZSEREDE REPRÆSENTANT..... 2</p> <p>ERKLÆRER UNDER DETTE ANSVAR, AT LANDBRUGSMASKINEN MED FUNKTION AF: MULLINER..... 3</p> <p>MODEL..... 4</p> <p>FABRIKNUMMER..... 4</p> <p>SERIENUMMER..... 5</p> <p>EN ER OVERENS ET I OVERENSSTEMMELSE MED ERKLÆRTE ØVERENSSTEMMELSE MED DIREKTIVENE I BREVET 2004/42/EF AERENDE PAK..... 6</p> <p>SAKT BEKREFTET/SENE I OVERENS 2004/170/EF, AERENDE PAK..... 7</p> <p>UNDERSKIFT/STYREMANNSKEDS NAVN, TITTEL OG BEOUDENHED..... 8</p> <p>STED OG DATO..... 9</p>
	<p><b>DE</b> EU-KONFORMITÄTSERKLÄRUNG GEMÄSS DEN RIKSDIREKTIV 2004/42/EG OCH 2004/170/EG</p> <p>VI..... 1</p> <p>UND UNDER REPRÄSENTANTEN..... 2</p> <p>ERKLÄRER UNDER ALLERLEST VERANTVÄRIGT, DÄS DAS LANDWIRTSCHAFTLICHE GERÄT MIT DER FUNKTION FOLGEND: MÜLLER..... 3</p> <p>MODELL..... 4</p> <p>WIRTSCHAFTSNAME..... 4</p> <p>SERIE-NUMMER..... 5</p> <p>3</p> <p>DAS GEGENSTAND DER ERKLÄRUNG IST DER BESTIMMUNG FOLGENDEN RICHTLINIEN GEMÄSS: 2004/42/EG, MODIFIZIERT DURCH..... 6</p> <p>4</p> <p>SOMME INCLUSE DANS LA DIRECTIVE 2004/170/CE, GEMÄSS SUIVANT..... 7</p> <p>NOM, FONCTION UND SIGNATURE DES PERSONNES AUTORISEES..... 8</p> <p>ORIG. DATE..... 9</p> <p>5</p>	<p><b>EN</b> CE DECLARATION OF CONFORMITY IN ACCORDANCE WITH DIRECTIVES 2004/42/EC &amp; 2004/170/EC</p> <p>WE..... 1</p> <p>AND OUR AUTHORIZED REPRESENTATIVE..... 2</p> <p>DECLARE UNDER OUR SOLE RESPONSIBILITY THAT THE AGRICULTURAL MACHINE WITH THE FUNCTION OF: MILLER..... 3</p> <p>MODEL..... 4</p> <p>COMMERCIAL NAME..... 4</p> <p>SERIAL NUMBER..... 5</p> <p>THE SUBJECT OF THE DECLARATION IS IN CONFORMITY WITH THE PROVISIONS OF DIRECTIVE 2004/42/EC, AMENDED BY..... 6</p> <p>AS WELL AS WITH THE PROVISIONS OF DIRECTIVE 2004/170/CE, AMENDED BY..... 7</p> <p>NAME, ROLE AND SIGNATURE OF THE AUTHORIZED PERSON..... 8</p> <p>LOCATION AND DATE..... 9</p>	<p><b>ES</b> DECLARACIÓN DE CONFORMIDAD CE DE ACUERDO CON LAS DIRECTIVAS 2004/42/CE Y 2004/170/CE</p> <p> NOSOTROS..... 1</p> <p> Y NUESTRO REPRESENTANTE AUTORIZADO..... 2</p> <p>DECLARAMOS, BAJO NUESTRA ÚNICA RESPONSABILIDAD, LA CONFORMIDAD DE LA MÁQUINA AGRÍCOLA CON LA FUNCIÓN DE: MOLINERA..... 3</p> <p>MODELO..... 4</p> <p>NOMBRE COMERCIAL..... 4</p> <p>NÚMERO DE SERIE..... 5</p> <p>A LA QUE SE REFIERE ESTA DECLARACIÓN CON LAS DISPOSICIONES DE LA DIRECTIVA 2004/42/CE, MODIFICADA POR..... 6</p> <p>ASÍ COMO LAS DISPOSICIONES DE LA DIRECTIVA 2004/170/CE, MODIFICADA POR..... 7</p> <p>NOMBRE, CARGO Y FIRMA DE LA PERSONA AUTORIZADA: 8</p> <p>LUGAR Y FECHA..... 9</p>
	<p><b>ET</b> EU-KONFORMITÄTSERKLÄRUNG GEMÄSS DEN RIKSDIREKTIV 2004/42/EG OCH 2004/170/EG</p> <p>VI..... 1</p> <p>JA MIIE VÕLLOLISUD EMBALAJA..... 2</p> <p>ERILDAVUSI TÄÄN TÄÄN VASTUUTAVAT, ET JÄRGENE PÕLVIKUMÄHINAGA..... 3</p> <p>MODEL..... 4</p> <p>KAUBANIMINE..... 4</p> <p>SERIEANUMBER..... 5</p> <p>7</p> <p>SEE OLEMA KÄSITÄTUD EUROPA ÜHENDUSE DIREKTIVIDE 2004/42/EÜ, MUUDA, ON MUUDA DIREKTIVIDE..... 6</p> <p>8</p> <p>NIIMI KÄSITÄTUD 2004/170/EÜ, NIIMI ON MUUDA DIREKTIVIDE..... 7</p> <p>VASTUTAV INIMENE, AMET JA ALLKIRJUTUS..... 8</p> <p>ASUKOHT JA PÄEV..... 9</p>	<p><b>FI</b> EU-KONFORMITÄTSERKLÄRUNG GEMÄSS DEN RIKSDIREKTIV 2004/42/EG OCH 2004/170/EG</p> <p>ME..... 1</p> <p>JA VALTUUTETUT EDUSTAJANNE..... 2</p> <p>VALTUUTUNUTEN TÄYLLÄ VASTUULLUUTUNUT, ETÄ MAATALOUSKONE, JOKA TOIMII MULLINAKONONA..... 3</p> <p>MODEL..... 4</p> <p>KAUPPIMENNÄ..... 4</p> <p>SÄRIENNUMERO..... 5</p> <p>JA JOKA MUOKOTTELA TÄMÄN VASTUUTUKSEN KANTAJANA, ON DIREKTIVIN 2004/42/EG JA SEN MUOKOTTELA..... 6</p> <p>7</p> <p>8</p> <p>9</p>	<p><b>NL</b> EU-KONFORMITEITSVERKLARING OVERENSSTEMMEND MET RICHTLIJNEN 2004/42/EG EN 2004/170/EG</p> <p>WEL..... 1</p> <p>EN ONZE BEVOEGDE VERTEGENWOORDIGER..... 2</p> <p>VERKLAREN DOORDIT ONZE UITSPREKING VOLTOEWENDEBARE CON DE VOORSCHRIFTEN VAN DE FUNCTIE VAN: MOLIJNWER..... 3</p> <p>MODEL..... 4</p> <p>WIRTSCHAFTSNAAM..... 4</p> <p>SERIE-NUMMER..... 5</p> <p>VERLOP DE VERKLARING BETREFFENDE HEET, EN OVERENSSTEMMING MET DE BEPALINGEN VAN DE RICHTLIJNEN 2004/42/EG..... 6</p> <p>7</p> <p>8</p> <p>9</p>

Breganze, ..... 9

nr.....  
635539007234

Thank you so much for reading.  
Please click the “Buy Now!”  
button below to download the  
complete manual.



After you pay.

You can download the most  
perfect and complete manual in  
the world immediately.

Our support email:

[ebooklibonline@outlook.com](mailto:ebooklibonline@outlook.com)