

**Workshop Service Manual**  
**MF 600 Tractors**

**Section A**  
**Introduction**

**Issue 03: 01 / 2003**

***Tractors comprehended by this manual: MF 630 - 650 - 660 - 680***

***Content of this Manual - structured in sections***

***See Table of Contents in the beginning of each section.***

**A** ..... Introduction

**B** ..... Splitting the Tractor

**C** ..... Reserved

**D1** ..... Carraro 4WD front axle: Ca 20.18, 20.21 and 20.29

**D2\*** ..... ZF 4WD front axle: APL 345, 350 and 359

*\* NOTE: It includes the primary drive box of the MF 630 and 650 tractors.*

*This box is presented in Section G3.*

**E** ..... Perkins Engines

**F** ..... Clutches

**G1** ..... Constant Mesh type 12x4 gearbox

**G2** ..... Eaton Synchronesh 12x4 gearbox

**G3** ..... 12x5 gearbox - ZF T3500

**H** ..... Rear axle

**I1** ..... Ferguson hydraulic lift system

**I2** ..... Hydrotronic hydraulic lift system

**I3** ..... Boschtronic hydraulic lift system

**J** ..... Power take-off: live and independent

**L** ..... Electrical System

**M** ..... Auxiliary Hydraulic System

**N** ..... Cab, air conditioning system and heating

**O** ..... Tractors' general basic specifications

---

1 -	Presentation	
1.1 -	How to use this Manual.....	5
1.2 -	Recording changes and updates made to this Manual .....	5
2 -	Safety.....	7
3 -	Correct workshop techniques .....	11
4 -	Basics of measurement	
4.1 -	Examples of instruments used in measurement .....	19
4.2 -	Examples of measurement.....	21
4.3 -	General concepts .....	26
5 -	General table of recommended torques for bolts .....	30
6 -	Technical units	
6.1 -	Conversion table .....	33
6.2 -	Equivalence between units - Imperial and SI systems.....	36
6.3 -	Prefixes of technical units .....	37
7 -	Loctite products for the workshop .....	38
8 -	AGCO environmental policy .....	39
9 -	Compulsory recycling of batteries .....	42

## 1 - Introduction

The purpose of this Workshop Manual is to help Dealers in the efficient maintenance of Massey Ferguson 600 Series Advanced Tractors.

Good after sale support is becoming increasingly important. Besides selling a good product, it is essential to provide good service, because that is the only way that to reach the greater goal: customer satisfaction.

With this in mind, the structure of the maintenance offered by the Dealer is of fundamental importance, and it should be performed only by trained personnel who are perfectly familiar with the different components of the tractor. For this reason, in addition to undertaking regular refresher courses at one of AGCO's Training Units, you should always consult this Manual before performing the service, whenever there is any doubt. Beside keeping it in usable condition, the Service Department should be aware of the updates that are introduced from time to time in the tractors and thus in the Manual.







## 2 - Safety

Your safety and the safety of others should be your first concern when doing maintenance work. For this to work, you need to do three things: be aware of what you are doing, use the tools correctly, and use the right protective equipment, both personal and collective. Awareness depends on each person, which means that every person needs to be aware of what they are doing and what risks they are taking in their work. When you learn about a safety rule, don't think of it as "don't do this, don't do that". First you should think about what might happen if you break that rule. Don't believe that old idea the "you have to learn by making mistakes", because the results of a mistake might be impossible to fix. Remember: After an accident, the first thing you think is that you would do anything to go back and not make that mistake. Walking 20 meters to get the "right tool" might be tiresome, but it's never going to be as much trouble as an accident that causes injury or damage.

As far as the rules go, it's impossible to write them all down. There are too many possible risks. What we have here are some basic rules as an example.

- ✓ Always use the tools and gear that are right for the job, especially when you are working with heavy assemblies and parts. Make sure that the hydraulic jack, the block and tackle, the chain are in perfect condition, and strong enough for the load.

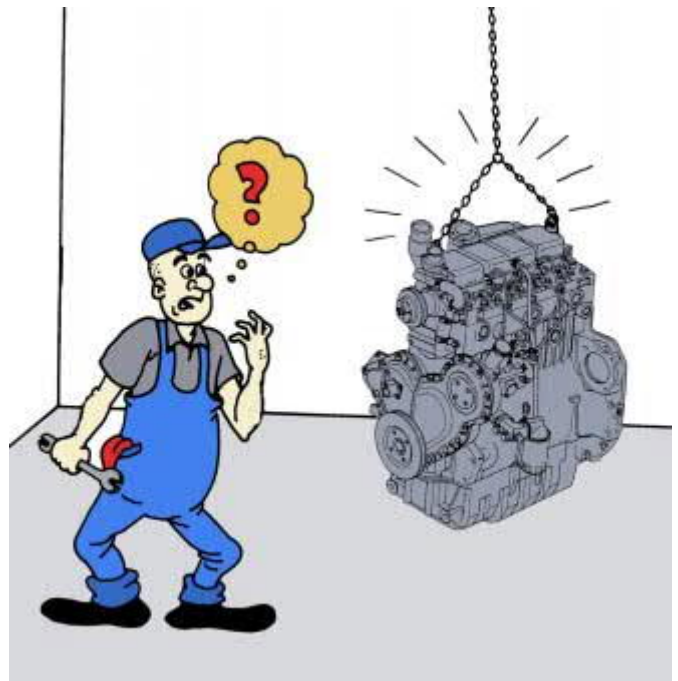

- ✓ Every time you use a power tool, check that it is grounded and that there are no exposed wires.



- ✓ Always disconnect the negative cable from the battery, so that no one can accidentally turn on the starter motor.

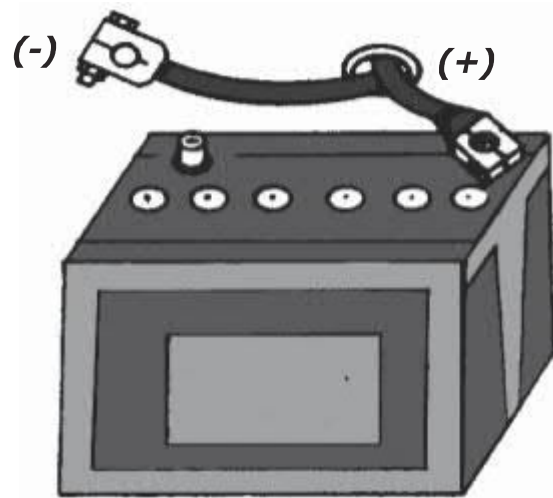

- ✓ When welding, as well as disconnecting the battery, you should use the proper protection: safety mask or goggles, gloves and apron. If you don't use eye protection, for example, you can do permanent damage to your eyes very quickly!





- ✓ When you take a tractor apart, you must use the right cranes and tackle. This will make the work safer, but also better quality and more profitable. Always use wooden wedges to chock the wheels which will not be removed in the job.

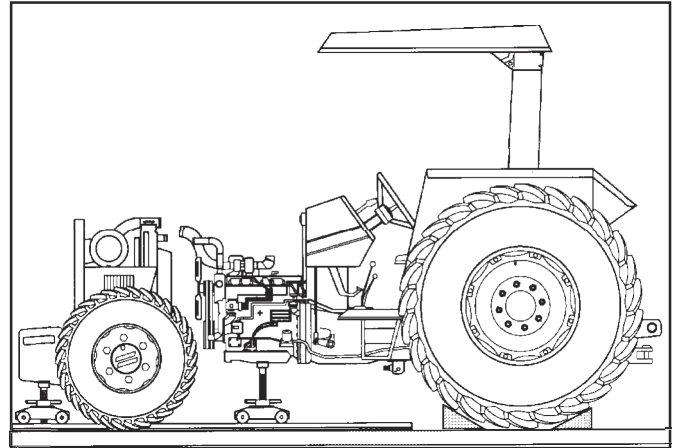

- ✓ Don't let the floor of the workshop get soaked with oil: it will cause accidents, and it lowers the tone of the shop. Remember: well organized workshop reflects the quality of the people that work there.

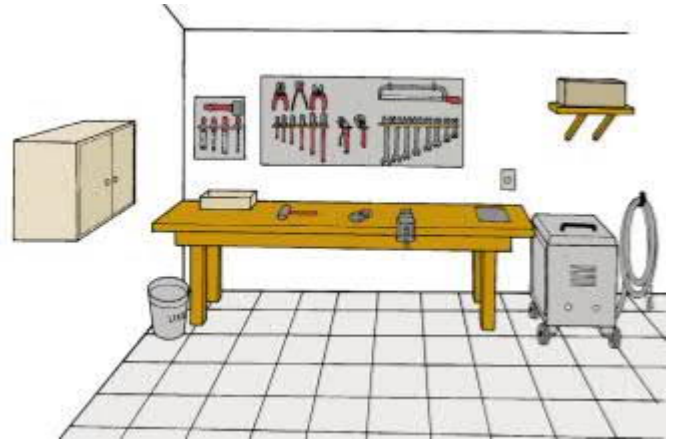

- ✓ Never stand under hanging loads. Even though the equipment is perfectly safe, there is no reason to tempt fate!



- ✓ Don't leave the engine running in a closed place without ventilation. It only takes a few minutes for the exhaust fumes to start to poison you.
- ✓ Don't smoke in the workshop. There is always the risk of fire with all the flammable products.



- ✓ Don't work with long hair or with loose clothes. If they get caught in moving machinery, they can cause serious accidents.

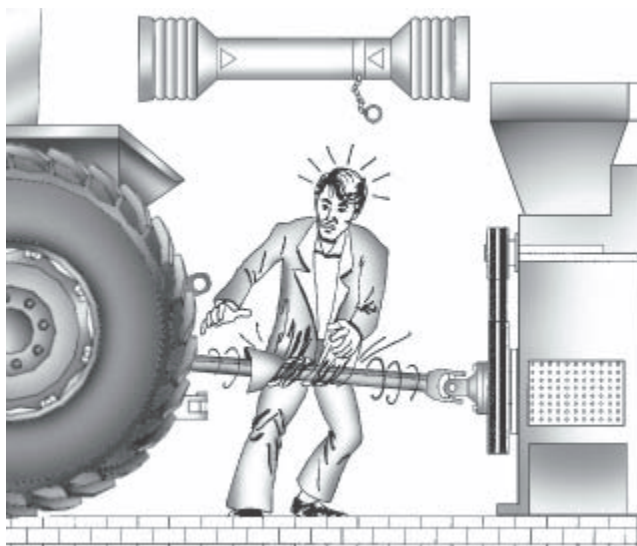

Before starting the engine of any tractor, check that no one is working on it, and that no tools have been left on it. .

Use a warning notice on the instrument panel to make sure no one turns on the engine if it has parts removed.

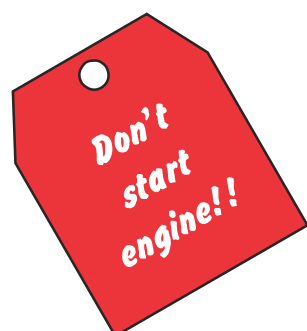
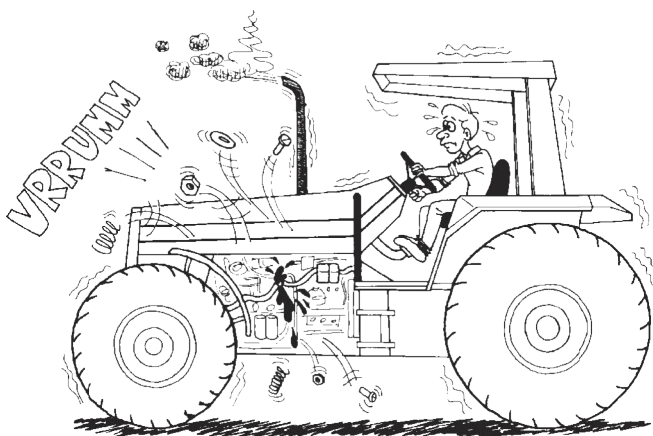

## 3 - Correct workshop techniques

Most of the repair and service procedures described in this manual are written with the assumption that the assembly you are working on has been completely disassembled and removed from the machine.

Many services, especially of some components, can be performed without removing the assembly from the machine. The mechanic must decide whether it is necessary or not, bearing in mind the level and amount of work to be done and the difficulty of Access.

The following important point should be remembered and put into practice.

### 1 - Identify the problem and clean the machine before taking it apart

If possible, do a complete diagnosis to determine how much work needs to be done and take all the precautions necessary to prevent any impurities from getting into the hydraulic, fuel and air systems.

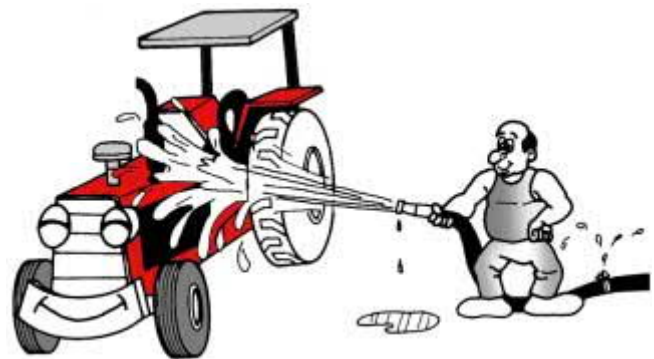

### 2 - Don't mix parts!

When you take an assembly apart, pay attention to special parts whose position cannot be changed. Separate the different nuts and bolts in divided trays with a screen bottom that permits oil and water to drain away.

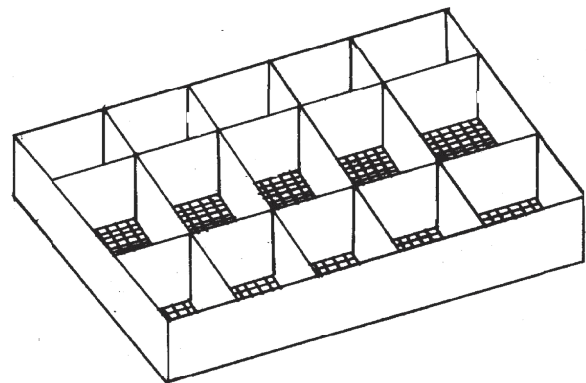

### 3 - Inspect parts during disassembly and wash them well

### 4 - Label parts and protect precision or polished surfaces

### 5 - Use Original Massey Ferguson Service Parts

Using non-genuine service parts can cause big problems.

Don't believe that parts are the same just because they look the same. Some parts have special properties, known only to the manufacturer. They are the result of special requirements established by intensive studies, engineering tests and field experience.

There is an ongoing program for future improvements of existing parts. Many of these improvements cannot be seen with the naked eye. That is why it is extremely important to use only genuine service parts.

## 6 - Rule for tensioning belts and chains

Use the following rule to check belt tension:

Apply a load of **10 to 15 kg** at the center of the largest unsupported distance.

Deflection in the belt or chain should be **1 to 2%** of this distance.

In the case of chains, apply sufficient force to bring all of the deflection to one side: deflection should be **1 to 2%** of the distance between the centers.

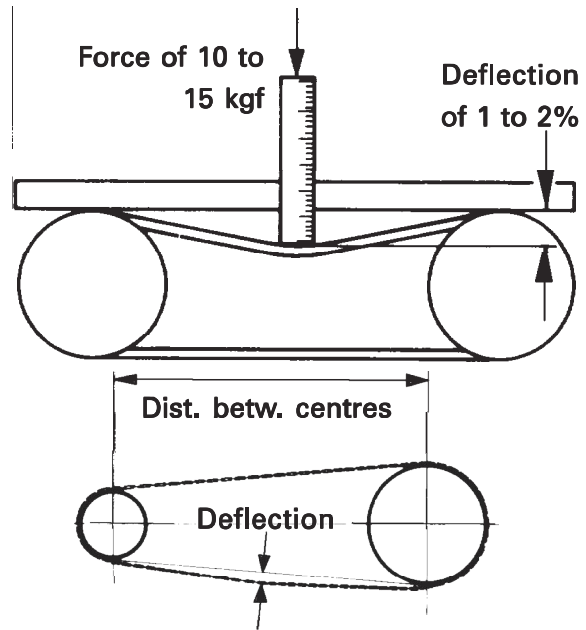

## 7 - Interference fitting of bushings, retainers and bearings

Always use a special tool for this job. Whenever necessary, apply the recommended force by means of a suitable press.

Improvisation in this case leads to wasted time and damaged parts, which will cause operating problems.

With bushings, check the internal diameter (or external diameter, if that is the case) and make an adjustment if you need to, based on the specifications in this manual for each situation.

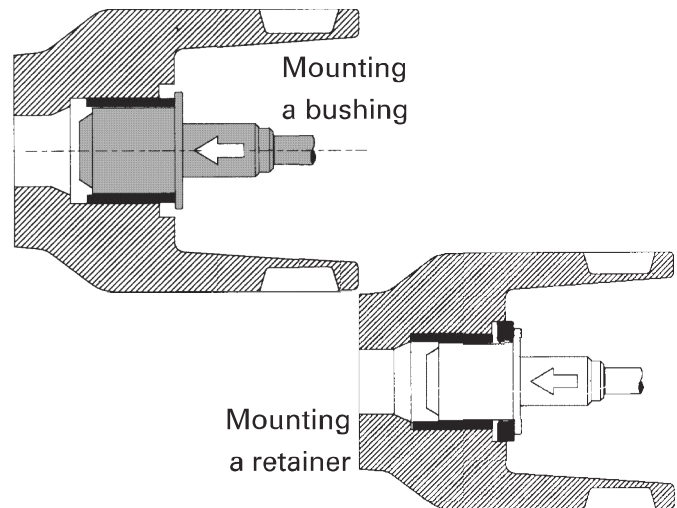

## 8 - Use correct pullers to remove pulleys, hubs and gears

Using hammers and levers may damage the parts, and will probably take longer than using the right tools!



### NOTE:

*Use a protector for the end of the axle.*

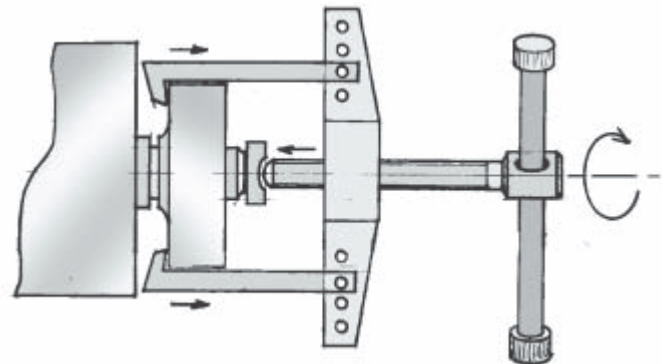

## 9 - Use the right tool for each job

Using the wrong tool just to save a few steps can end up wasting a lot more time after you damage a hex nut, a screw slot...

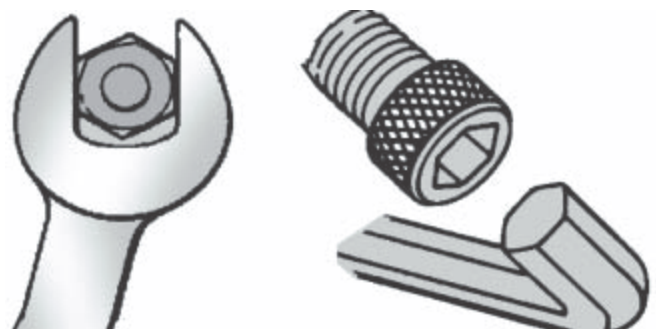

### 10 - Removing a stud that has broken in place

Drill a hole about half the diameter of the broken stud and use a bolt extractor with the opposite thread to the stud.

Then remove the stud by turning the bolt extractor counter-clockwise (in the case of a bolt with right hand thread).

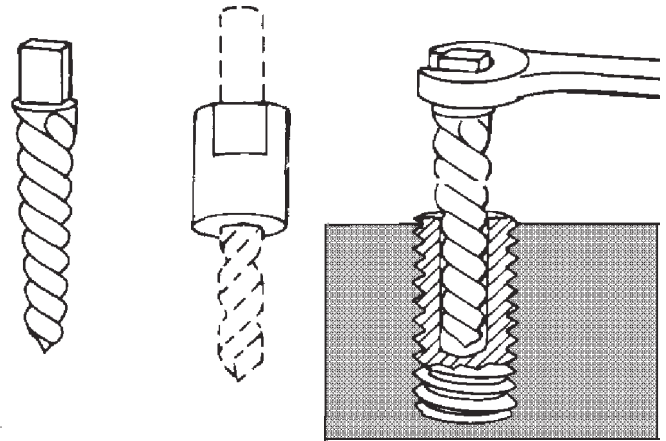

**NOTE:**

When you are putting a bolt in a dead end hole, make sure there is no oil or other impurity in the hole. Oil forms a hydraulic block which may damage the housing.

### 11 - Removing stuck nuts

There are lots of ways, it depends on the situation. But, the surrounding parts cannot be damaged either way.

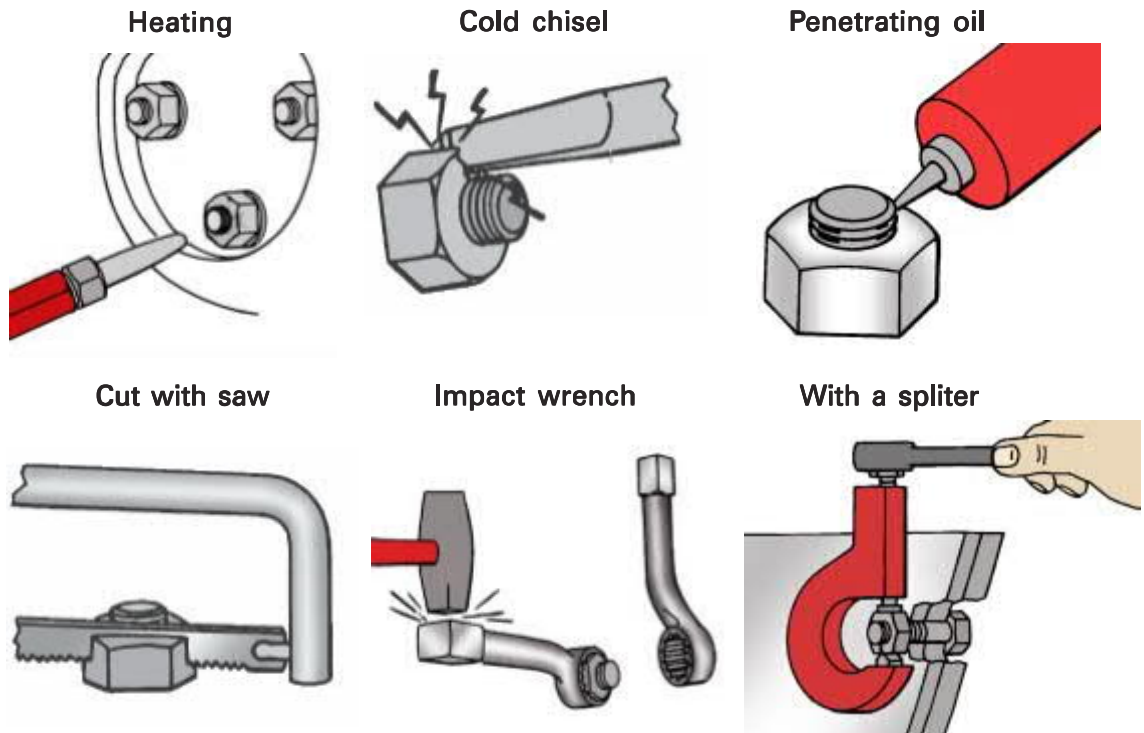

### 12 - Correct locking of nuts and bolts

With a cotter pin or some other means, check what condition it is in. It is usually best to replace them after disassembly.

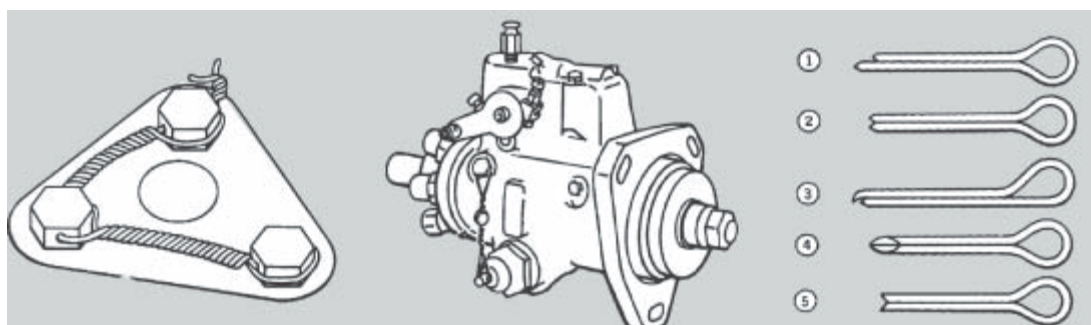

### 13 - How to stop nuts or bolts from shaking loose under normal working conditions

There are also a number of ways. Experience and common sense will tell you the best procedure for each situation:

Lock sealant

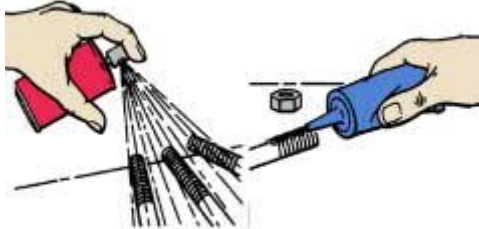

Spring washer



Counter-nut

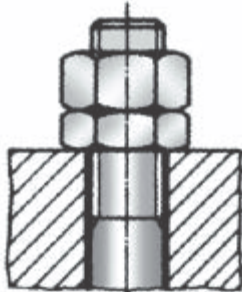

Tab washer

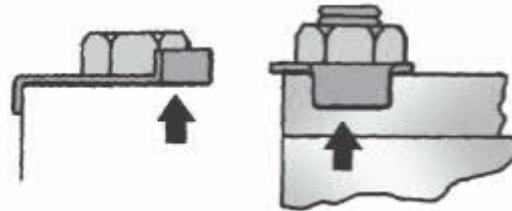

### 14 - Whenever you use force on a wrench, always pull it towards you

If you push on the wrench and it slips, you are likely to hurt your hands.

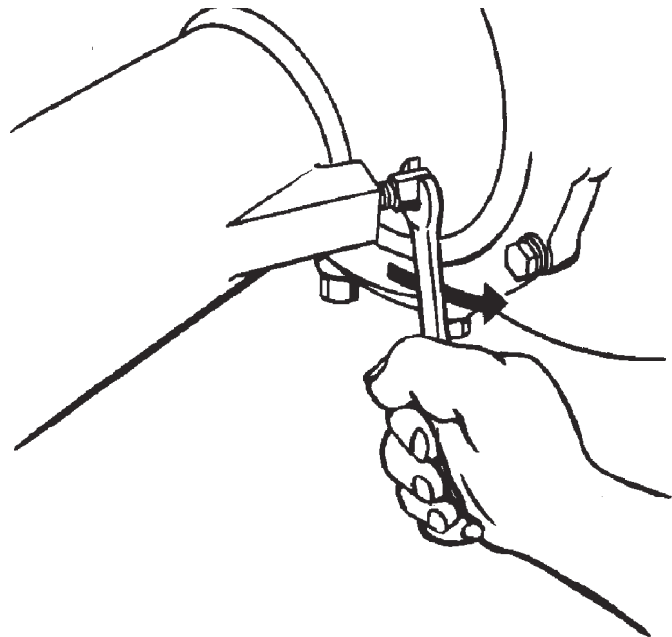

### 15 - Use open wrenches the right way

Working with the wrench reversed puts more stress on it. Don't improvise.

Use an open wrench in both grades only to remove hard-to-access bolts, alternately, until the bolt or nut is released.

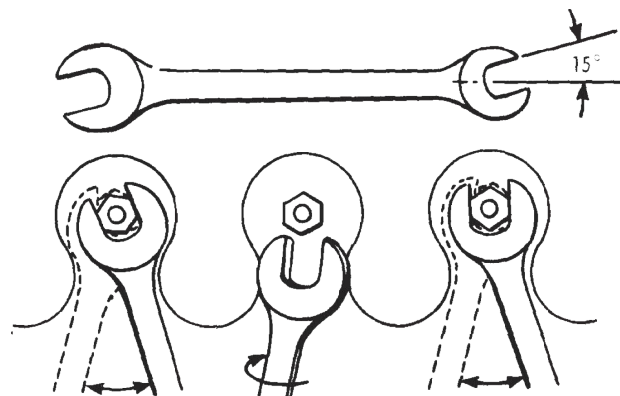
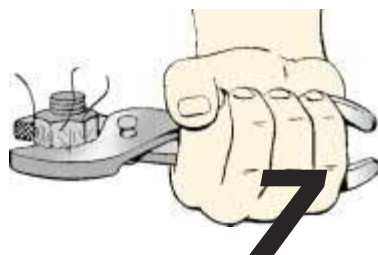
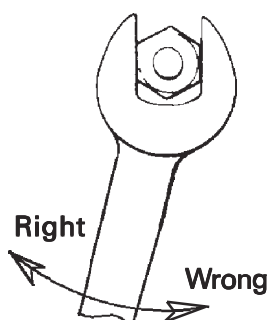

### 16 - Removing nuts from injector tubes

A box wrench is best, but first you need to cut an opening in the wrench for the tube to pass through. Use this wrench only for this purpose.

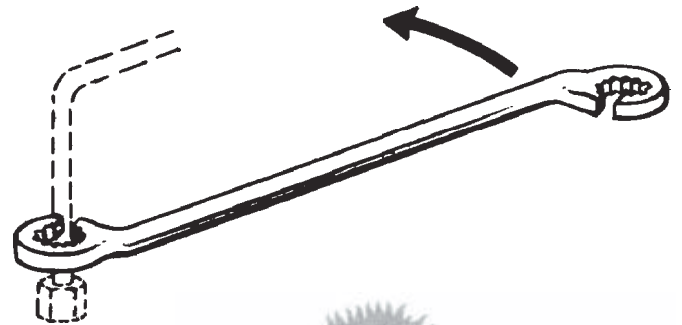

### 17 - Mounting parts with interference

Always heat the external part (bearings, hubs, etc) and/or cool the internal part (axles, valve guides and seats, etc).

Heating makes a part expand, and cooling makes it shrink, so using this method you make the fitting easier and reduce damage to the parts.

The heating should never be done with a direct flame, because this would weaken the part and make it brittle.

You should heat the part in hot oil (80 to 90°C / 176 to 194°F) or by electrical induction.

Cooling can be done in a freezer, or in a bucket of ice or dry ice.

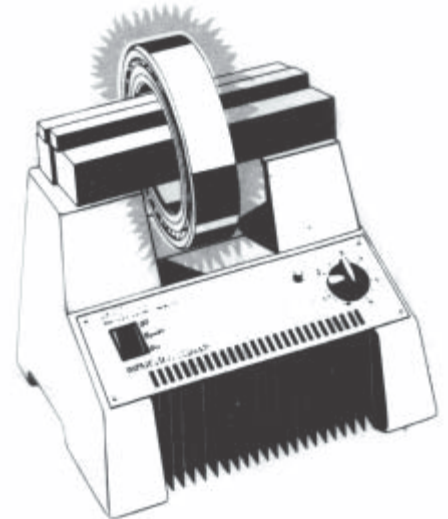

### 18 - When welding

Always disconnect the battery, and remember: Attach the negative terminal (-) of the welder to the part you are welding (+). This is to avoid having a high current flowing through pieces like bearings and damaging them.

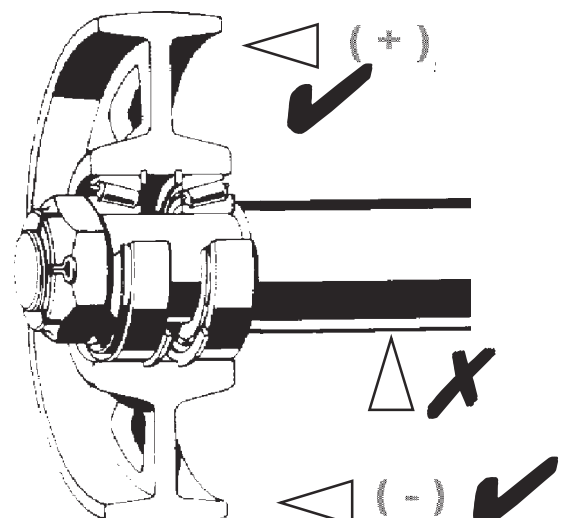

Thank you so much for reading.  
Please click the “Buy Now!”  
button below to download the  
complete manual.



After you pay.

You can download the most  
perfect and complete manual in  
the world immediately.

Our support email:

[ebooklibonline@outlook.com](mailto:ebooklibonline@outlook.com)