

PTX600 PRECISION TILLAGE

Service Manual

NWC-010V1

CASE *iii*

TABLE OF CONTENTS

Pages listed are a table of contents for that section

Section - Title	Page
1 - SAFETY	1-1
Safety	
Decal Locations	
Reflector Decals, Slow Moving Vehicle Sign and	
Transport Lighting	
Transport Lighting Wiring Schematic	
2 - ADJUSTMENTS	2-1
General Service Information	
Wing Lift Adjustment - Three Section Outer Wing	
Leveling Procedure	
Final Leveling	
Wheel Standard Restraint Chain Adjustment	
Sweep Pitch Adjustment	
Setting the Depth Gauge	
Weight Transfer Kit - NW-547K	
3 - MECHANICAL SERVICE	3-1
Specifications	
Machine Specification-North America-Imperial Units	
Machine Specification-North America-Metric Units	
Machine Specification-Australia - Imperial Units	
Machine Specification-Australia - Metric Units	
Troubleshooting Tables	
Grease Locations	
Daily Maintenance (Every 10 Hours)	
Weekly Maintenance (Every 50 Hours)	
Semi-Annual Maintenance (Every 200 Hours)	
Yearly Maintenance (Before Seasonal Operation or	
Before Storage)	
Welding Procedures	
Fold Linkages	
Wheel Bolt Torque	
Tire Pressures and Hub and Spindle Details	
Hubs / Spindles / Wheel / Walking Beams	
Caster Hub and Spindle Maintenance	
Removal and Replacement of Bushings on Bell Crank	
Assembly	
3 - MECHANICAL SERVICE Cont;	3-1
Ram Mount Depth Stop	
Remote Switch Installation	
Anhydrous Hitch	
Mud Scraper Installation	
4 - HYDRAULICS	4-1
Replace Seals in Cylinders	
Hydraulic Cylinder Components	
Hydraulic Schematics	
Ram Mount Depth Stop Connection	
5 - ELECTRICAL	5-1
Connector Service Kit	
6 - TRIPS AND OPENERS	6-1
Troubleshooting Tables	
Trip Compressor Tool Kit	
Tension Link Kit TP-133K - 550lb Trip	
Adjustment of Trip Assemblies	
Anti-Skewing Trip Shim Installation	
Trip Shim Kit for 650lb Trip	
7 - AIR SYSTEM	7-1
Troubleshooting Tables	
Hoses	
Theory of Operation - Air System	
Methods of Determining Adequate Carrying Velocities	
Header Assemblies	
Hose Holder Brackets and Distribution Clamps	
8 - OPTIONS	7-1
Harrow	
Heavy Harrow	
Press Wheels / Packer Gangs	
Endmarker	

NOTE: Case Corporation reserves the right to make improvements in design or changes in specifications at any time without incurring any obligation to install them on units previously sold.

SECTION 1

SAFETY

CONTENTS OF THIS SECTION

	Page
SAFETY	1-3
General Safety Practices	1-4
Servicing Safety Precautions	1-4
Safety During Operation	1-5
Air and Air Hoses	1-8
Hydraulics and Hydraulic Leaks	1-8
Shields	1-9
Electrical	1-9
Tires	1-9
Safety During Transport	1-10
Safety Decals	1-10
 DECAL LOCATIONS	 1-11
 REFLECTOR DECALS, SLOW MOVING VEHICLE SIGN AND TRANSPORT LIGHTING	 1-13
 TRANSPORT LIGHTING WIRING SCHEMATIC	 1-14

SAFETY

SAFETY-ALERT SYMBOL



This symbol is used to denote possible danger and care should be taken to prevent bodily injury. This symbol means **ATTENTION! BECOME ALERT! YOUR SAFETY IS INVOLVED!**

THREE WORDS USED IN CONJUNCTION WITH THE SAFETY-ALERT SYMBOL:

DANGER!



Indicates an imminently hazardous situation that, if not avoided, will result in death or serious injury. The color associated with Danger is RED.

WARNING!



Indicates a potentially hazardous situation that, if not avoided, could result in death or serious injury. The color associated with Warning is ORANGE.

CAUTION!



Indicates a potentially hazardous situation that, if not avoided, may result in minor or moderate injury. The color associated with Caution is YELLOW.

GENERAL SAFETY PRACTICES

REVIEW this manual and operator's manual before servicing equipment.

NEVER allow anyone unfamiliar, untrained, or complacent to operate the cultivator.

ALWAYS USE the jack supplied when unhooking the cultivator.

NEVER transport the cultivator at speeds higher than 32 km/h (20 mph).

MAINTAIN YOUR CULTIVATOR in proper working condition. Unauthorized modifications to the machine may impair function and/or safety and affect machine life.

It is PREFERRED to transport the cultivator separately without an air cart attached. However, this is not always practical. If you are transporting the cultivator with a tow between air cart, the air cart should be full. If you are transporting the cultivator with a tow behind air cart, the air cart should be empty.

BE SURE the cultivator is securely fastened to a large farm tractor or an air cart that is attached to a large farm tractor before operating hydraulics.

USE EXTREME CARE when making adjustments.

KEEP CHILDREN AWAY from all farm equipment.

SERVICING SAFETY PRECAUTIONS

BLOCK the wheels to prevent movement when servicing.

BE SURE the press wheels are blocked and wing lock pins are in place before servicing or adjusting opener assemblies or working on the cultivator.

CAUTION!



The tractor engine should be stopped and the wheels blocked to prevent any movement during servicing.

Always be sure that the depth control safety lock is in place when servicing the cultivator.

Always be sure the wings are in field position before servicing the cultivator.

Escaping hydraulic fluid is a serious hazard. Escaping hydraulic fluid that is under pressure can penetrate the skin, causing serious injury. Relieve pressure before disconnecting the hydraulic lines.

Check/tighten all connections before applying pressure.

Never use your hand to search for leaks. Use a piece of cardboard or paper. If any fluid is injected into the skin, seek immediate medical attention. Gangrene may result if the wound is not treated within a few hours. Check your hydraulic fluid containers for warnings concerning the hydraulic fluids you use.

DO NOT walk within the radius of raised cultivator wings.

SAFETY DURING OPERATION

DO NOT ALLOW ANYONE ON THE CULTIVATOR while operating the cultivator hydraulics.

NEVER disconnect the tractor from the cultivator while the cultivator wings are raised.

KEEP CHILDREN AWAY from the cultivator during operation.

NEVER STAND within the radius of the raised wings. Hydraulic or mechanical failure may result in rapid or uncontrolled falling of the wings.

OPERATE the wings only on level ground with the depth control fully raised.



097002S

PARK ON LEVEL GROUND and block adequately.

AVOID moving machines.

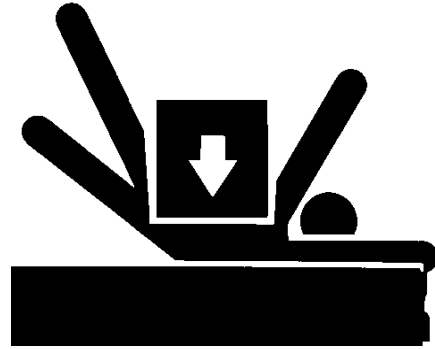

098001M1

DISENGAGE POWER AND SHUT DOWN the tractor engine (remove the key from the tractor ignition), be certain that all moving parts have stopped, and all pressure in the system is relieved BEFORE cleaning, adjusting or lubricating the cultivator.

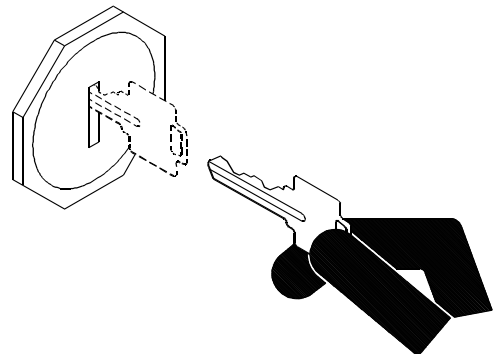

192169C

SECTION 1 - ⚠ SAFETY

READ the operators manual thoroughly.

KEEP service area clean.



098002M1

DO NOT enter tight areas.

BE CERTAIN machine is tagged 'out of order' or work area is supervised.

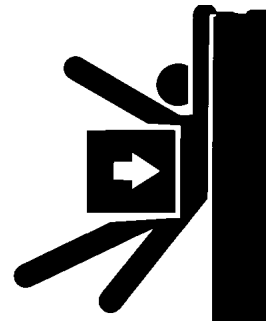

098003M1

DO NOT work around rotating equipment. Loose clothing, rings, watchbands, etc. may get caught and cause serious injury.

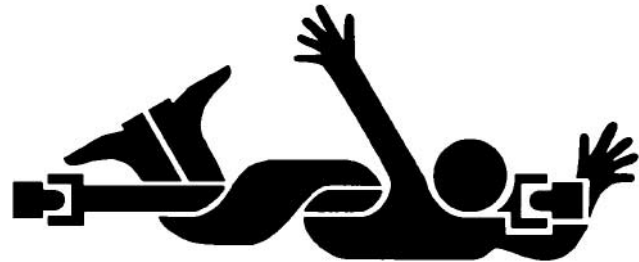

097001S

BE CERTAIN all moving parts have stopped before servicing.



098004M1

AVOID toxic vapors. Breath clean air.

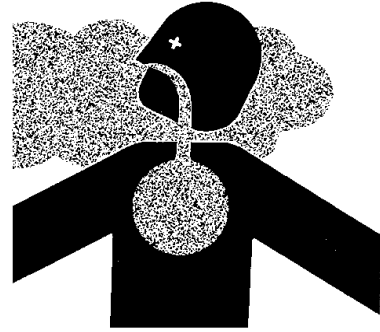

0960039S

DO NOT permit smoking.



196150S

WEAR protective clothing.

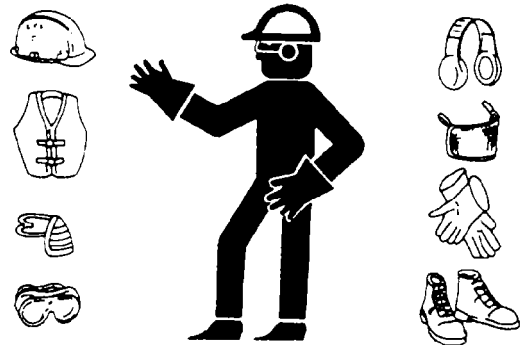

192078S

AIR AND AIR HOSES

COMPRESSOR HOSES may move unexpectedly when suddenly disconnected.



098005M1

USE PROPER air nozzles. Do not use compressed air to clean clothes or direct it toward any part of yourself.

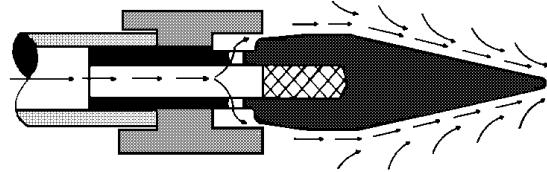

098006M1

AVOID getting chemicals into eyes. Use eye protection.

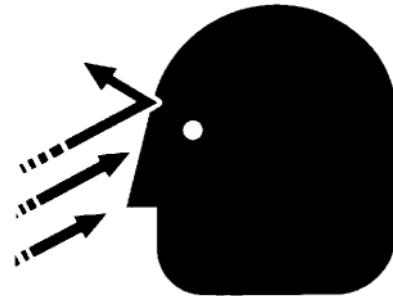

098007M1

HYDRAULICS AND HYDRAULIC LEAKS

AVOID high-pressure fluids.

ESCAPING HYDRAULIC FLUID IS A SERIOUS HAZARD. Escaping hydraulic fluid that is under pressure can penetrate the skin causing serious injury. Relieve pressure before disconnecting the hydraulic lines. Check/tighten all connections **BEFORE** applying pressure.

BEWARE excessive hydraulic pressure. Explosive structural failure can result.

BEWARE air locks in cylinders. Large cylinder displacements can occur without hydraulic oil flow.

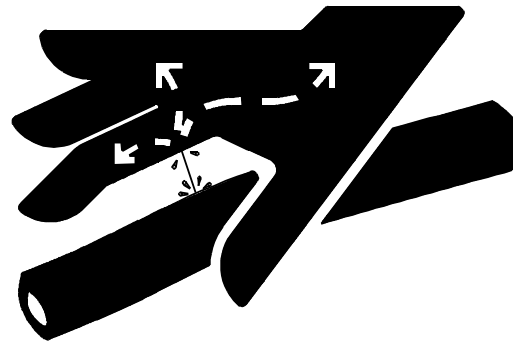

000002C

SHIELDS

REPAIR damaged shields.

KEEP all shields in place.

BE EXTRA CAUTIOUS when repairing or servicing without protective shields.

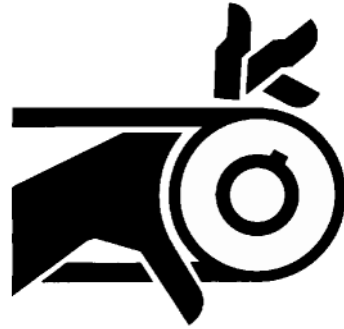

098008M1

ELECTRICAL

REMOVE the ground wire to avoid arcing contacts.

REMOVE GROUND WIRE when welding.



098009M1

TIRES

USE A CAGE IF POSSIBLE when setting tires on rims.

AVOID excessive air pressure.

DO NOT OVERINFLATE tires. NEVER lean over a tire while inflating it.



0960041S

SAFETY DURING TRANSPORT

CHECK with local authorities regarding transport on public roads. Obey all applicable laws and regulations.

ONLY TOW at a safe speed (32 km/h/ 20 mph). Use caution when turning corners or meeting traffic.

BE SURE safety lighting is plugged in and that the red taillight(s), amber flashers, and amber signal lights are all working properly.

ALWAYS be certain that no one is behind or near the cultivator before moving it.

BE SURE all safety transport locks are in place before transporting the cultivator.

BE SURE the reflector decals are clearly visible from all sides of the cultivator and the 'Slow Moving Vehicle' sign is at the rear of the cultivator in clear view of overtaking traffic.

BE SURE the tractor weight is equal to or greater than the total weight of the air cart and cultivator.

BE SURE all the wheel bolts are torqued to proper specifications before transporting the cultivator.

WATCH for power poles and overhead power lines.

ALWAYS lock the tractor drawbar when transporting the cultivator.

ALWAYS park the cultivator on level ground and block the wheels before unhooking from the towing vehicle.

NEVER subject the cultivator to steep side grades while in transport position.

ALWAYS use the hitch jack supplied with the cultivator when unhooking from the tractor.

NEVER brake or decelerate during cornering.

ALWAYS enter corners slowly. SLOW the machine to turning speed before entering a corner. DO NOT decelerate while executing the turn.

SAFETY DECALS

KEEP SAFETY DECALS CLEAN. Wipe clean when necessary.

CHECK that the safety decals are not obstructed by the openers. If the decals are covered up, replace in a location that is clear to view.

REPLACE missing or unreadable decals. New decals are available from your dealer.

To replace decals:

1. Remove the old decal. Clean the area where the new decal will be affixed.
2. Remove the decal backing. Carefully affix the decal to the cultivator.
3. Work the air bubbles out from under the decal. Use a clean piece of paper or the decal backing itself.

DECAL LOCATIONS

The following safety decals are affixed to the cultivator.

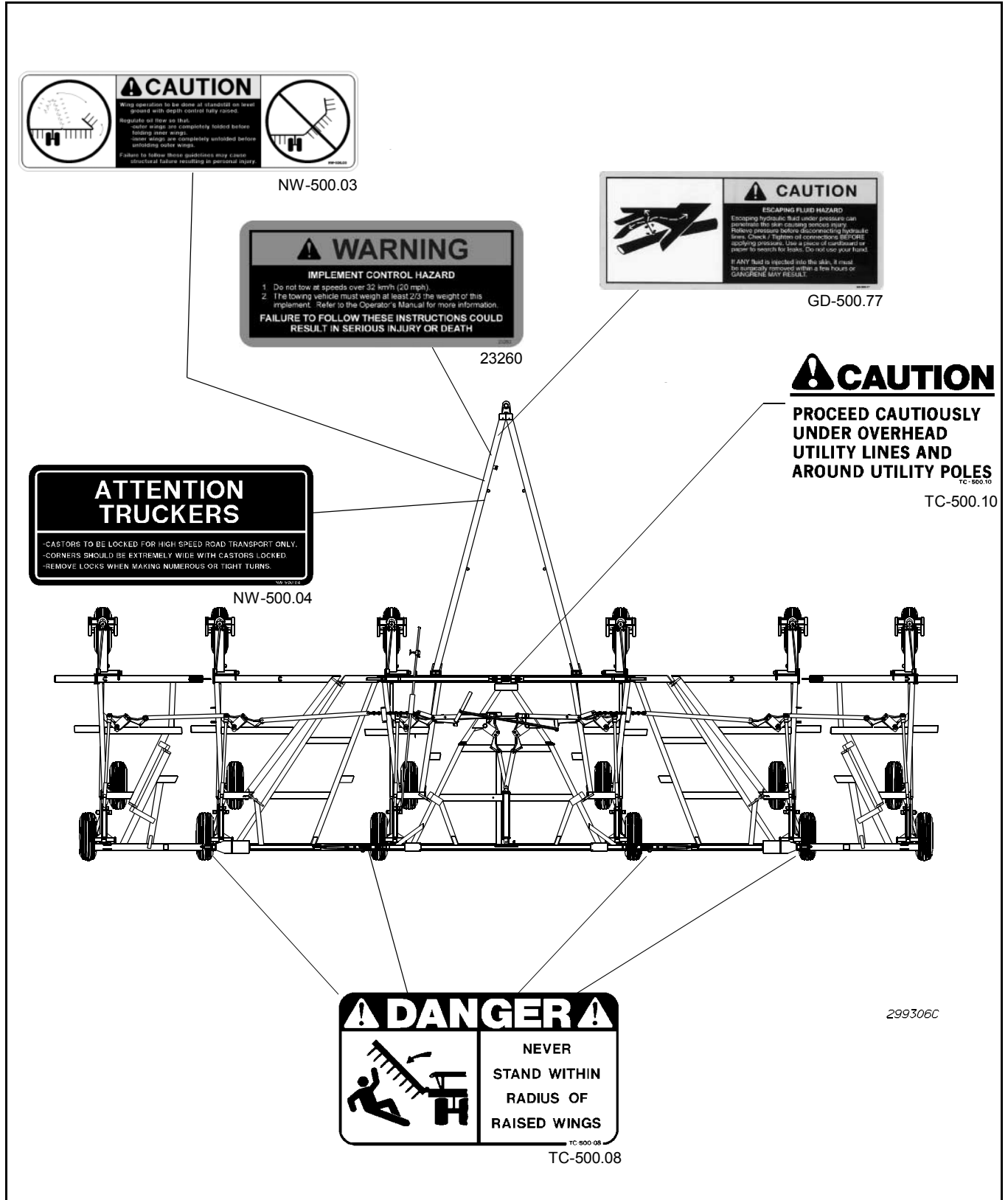

Safety Decal Locations

SECTION 1 -  SAFETY

	Part Number	Type of Decal	Name of Decal	Location
1	TC-500.08	DANGER	DECAL RAISED WINGS	Decal on the front and rear wing bars near the hinge.
2	TC-500.10	CAUTION	DECAL CAUTION PROCEED	Decal located on the king post link on the center section facing forward.
3	NW-500.03	CAUTION	DECAL WING UP/DOWN SEQUENCE	Decal located on the side of the left hitch pole facing outward.
4	GD-500.77	CAUTION	DECAL CAUTION HYDRAULICS	Decal located on the top of the left hitch pole.
5	NW-500.04	ATTENTION	DECAL TRUCKER CASTER LOCK	Decal located on the top of the left hitch pole.
6	432589A1	AMBER REFLECTIVE	DECAL REFLECTOR AMBER 2.9 X 4.3	Decals located on the front wing diagonal bars facing front. They are also on the bottom of the front and rear wing bars near the hinge.
7	412907A1	RED REFLECTIVE	DECAL REFLECTOR RED 2.9 X 4.3	Decals located on the rear of the rear wing bars near the hinge. They face to the rear of the machine.
8	23260	WARNING	DECAL "IMPLMNT CNTRL HAZARD"	Transport Speed Decal located on the hitch.

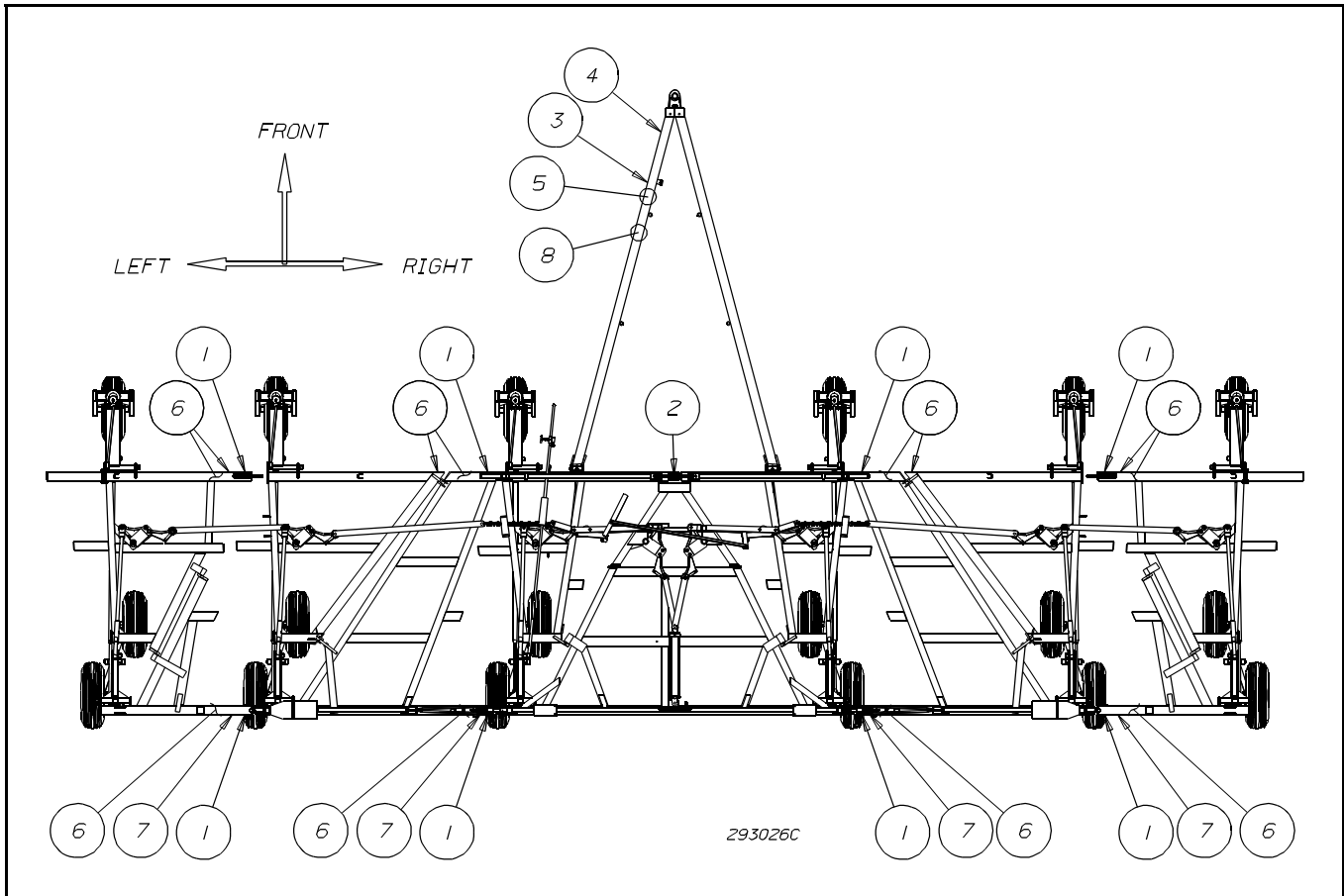

Decal Locations (Reflective and Safety)

REFLECTOR DECALS, SLOW MOVING VEHICLE SIGN AND TRANSPORT LIGHTING

REF	DESCRIPTION	REF	DESCRIPTION
1	TAIL LIGHT ASSEMBLY, RED	10	LIGHT ASSEMBLY, WARNING - AMBER
2	LENS, RED	11	BACKING PLATE, UNIVERSAL
3	BULB, DOUBLE CONTACT	12	U-BOLT SQ .5" X 4.125"W X 5.25"D
4	MOUNT BRACKET, RED LIGHT	13	LOCKNUT .313" UNC
5	MOUNT BRACKET, RED LIGHT	14	BRACKET, PLUG RECEPTACLE
6	2345 BOLT .5 X 3.5 GR. 5	15	BOLT .313 X 1.5 GR. 5
6	BOLT .5 X 5.5 GR. 5	16	BOLT .5 X 1 GR. 5
6	BOLT .5 X 7.5 GR. 5	21	BULB, SINGLE CONTACT
7	LOCKNUT .5" UNC	22	LENS, AMBER
8	BRACKET, AMBER LIGHT	23	CABLE TIE STRAP 21"
9	SHIELD, AMBER SAFETY LIGHT	23	CABLE TIE STRAP 14"

CultivatorTransport Lights, Reflector Decals and SMV Sign

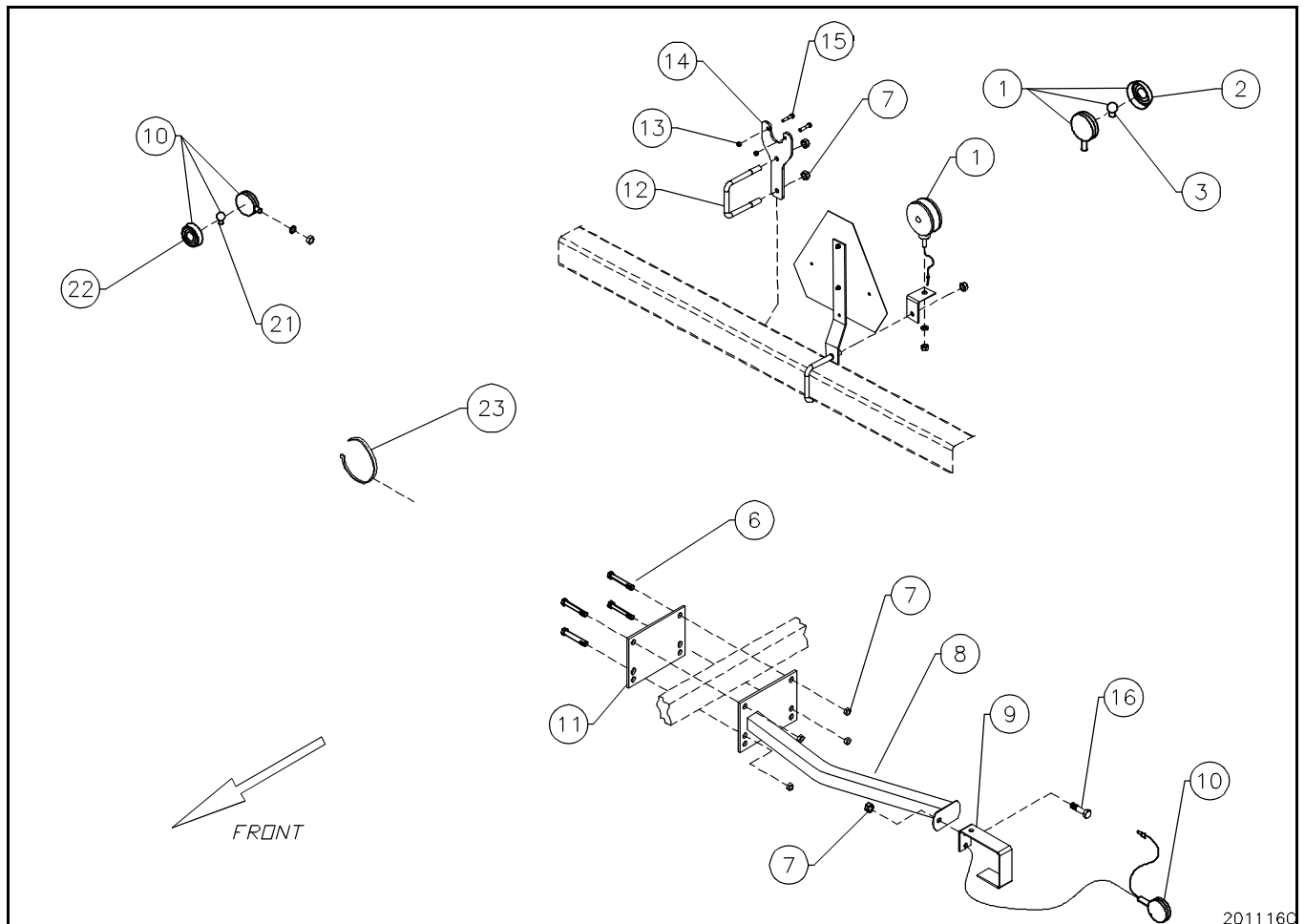

201116C

Safety Lighting Assembly

Thank you so much for reading.
Please click the “Buy Now!”
button below to download the
complete manual.



After you pay.

You can download the most
perfect and complete manual in
the world immediately.

Our support email:

ebooklibonline@outlook.com