

Product: EXCAVATOR  
Model: 313B EXCAVATOR BAS  
Configuration: 313B CR EXCAVATOR BAS00001-UP (MACHINE)

## **Operation and Maintenance Manual 313B CR Excavator**

Media Number -SEBU7297-00

Publication Date -01/12/1999

Date Updated -09/10/2001

s00037320

## **Foreword**

SMCS - 6001-011; 6001; 6101; 6102; 6523

## **Literature Information**

This manual should be stored in the operator's compartment in the literature holder or seat back literature storage area.

This manual contains safety information, operation instructions, transportation information, lubrication information and maintenance information.

Some photographs or illustrations in this publication show details or attachments that can be different from your machine. Guards and covers might have been removed for illustrative purposes.

Continuing improvement and advancement of product design might have caused changes to your machine which are not included in this publication. Read, study and keep this manual with the machine.

Whenever a question arises regarding your machine, or this publication, please consult your Cat dealer for the latest available information.

## **Safety**

The safety section lists basic safety precautions. In addition, this section identifies the text and locations of warning signs and labels used on the machine.

Read and understand the basic precautions listed in the safety section before operating or performing lubrication, maintenance and repair on this machine.

## **Operation**

The operation section is a reference for the new operator and a refresher for the experienced operator. This section includes a discussion of gauges, switches, machine controls, attachment controls, transportation and towing information.

Photographs and illustrations guide the operator through correct procedures of checking, starting, operating and stopping the machine.

Operating techniques outlined in this publication are basic. Skill and techniques develop as the operator gains knowledge of the machine and its capabilities.

## Maintenance

The maintenance section is a guide to equipment care. The Maintenance Interval Schedule (MIS) lists the items to be maintained at a specific service interval. Items without specific intervals are listed under the "When Required" service interval. The Maintenance Interval Schedule lists the page number for the step-by-step instructions required to accomplish the scheduled maintenance. Use the Maintenance Interval Schedule as an index or "one safe source" for all maintenance procedures.

### Maintenance Intervals

Use the service hour meter to determine servicing intervals. Calendar intervals shown (daily, weekly, monthly, etc.) can be used instead of service hour meter intervals if they provide more convenient servicing schedules and approximate the indicated service hour meter reading. Recommended service should always be performed at the interval that occurs first.

Under extremely severe, dusty or wet operating conditions, more frequent lubrication than is specified in the maintenance intervals chart might be necessary.

Perform service on items at multiples of the original requirement. For example, at every 500 service hours or 3 months, also service those items listed under every 250 service hours or monthly and every 10 service hours or daily.

## California Proposition 65 Warning

Diesel engine exhaust and some of its constituents are known to the State of California to cause cancer, birth defects, and other reproductive harm.

Battery posts, terminals and related accessories contain lead and lead compounds. **Wash hands after handling.**

## Certified Engine Maintenance

Proper maintenance and repair is essential to keep the engine and machine systems operating correctly. As the heavy duty off-road diesel engine owner, you are responsible for the performance of the required maintenance listed in the Owner Manual, Operation and Maintenance Manual, and Service Manual.

It is prohibited for any person engaged in the business of repairing, servicing, selling, leasing, or trading engines or machines to remove, alter, or render inoperative any emission related device or element of design installed on or in an engine or machine that is in compliance with the

regulations (40 CFR Part 89). Certain elements of the machine and engine such as the exhaust system, fuel system, electrical system, intake air system and cooling system may be emission related and should not be altered unless approved by Caterpillar.

## Machine Capacity

Additional attachments or modifications may exceed machine design capacity which can adversely affect performance characteristics. Included would be stability and system certifications such as brakes, steering, and rollover protective structures (ROPS). Contact your Cat dealer for further information.

## Cat Product Identification Number

Effective First Quarter 2001 the Cat Product Identification Number (PIN) has changed from 8 to 17 characters. In an effort to provide uniform equipment identification, Caterpillar and other construction equipment manufacturers are moving to comply with the latest version of the product identification numbering standard. Non-road machine PINs are defined by ISO 10261. The new PIN format will apply to all Cat machines and generator sets. The PIN plates and frame marking will display the 17 character PIN. The new format will look like the following:



---

Illustration 1

g00751314

Where:

1. Caterpillar's World Manufacturing Code (characters 1-3)
2. Machine Descriptor (characters 4-8)
3. Check Character (character 9)
4. Machine Indicator Section (MIS) or Product Sequence Number (characters 10-17). These were previously referred to as the Serial Number.

Machines and generator sets produced before First Quarter 2001 will maintain their 8 character PIN format.

Components such as engines, transmissions, axles, etc. and work tools will continue to use an 8 character Serial Number (S/N).

---

Product: EXCAVATOR  
Model: 313B EXCAVATOR BAS  
Configuration: 313B CR EXCAVATOR BAS00001-UP (MACHINE)

## Operation and Maintenance Manual 313B CR Excavator

Media Number -SEBU7297-00

Publication Date -01/12/1999

Date Updated -09/10/2001

i01222670

## Safety Signs and Labels

SMCS - 7000; 7405

There are several specific safety signs on this machine. The exact location of the hazards and the description of the hazards are reviewed in this section. Please become familiarized with all safety signs.

Make sure that all of the safety signs are legible. Clean the safety signs or replace the safety signs if you cannot read the words. Replace the illustrations if the illustrations are not visible. When you clean the safety signs, use a cloth, water and soap. Do not use solvent, gasoline, or other harsh chemicals to clean the safety signs. Solvents, gasoline, or harsh chemicals could loosen the adhesive that secures the safety sign. Loose adhesive will allow the safety sign to fall.

Replace any safety sign that is damaged, or missing. If a safety sign is attached to a part that is replaced, install a safety sign on the replacement part. Any Caterpillar dealer can provide new safety signs.

### Do Not Operate

---

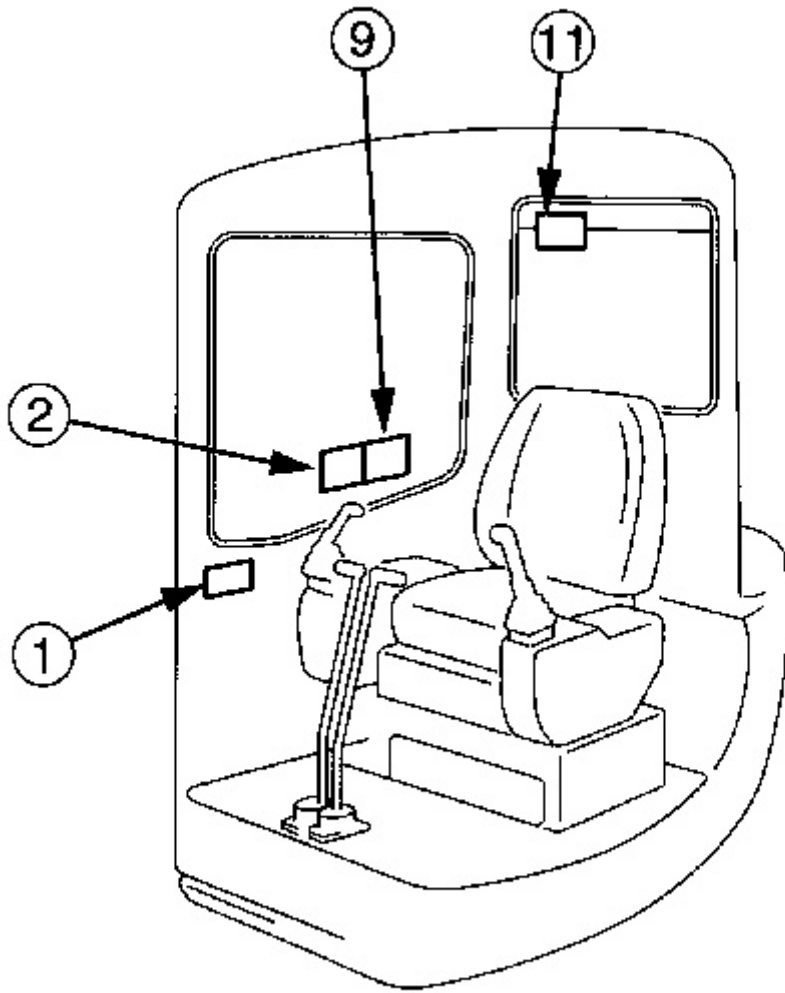

---

Illustration 1

g00661164

This warning label (1) is positioned in the cab.

---

 **WARNING**

**DO NOT OPERATE OR WORK ON THIS MACHINE UNLESS YOU HAVE READ AND UNDERSTAND THE INSTRUCTIONS AND WARNINGS IN THE OPERATION AND MAINTENANCE GUIDES. FAILURE TO FOLLOW THE INSTRUCTIONS OR HEED THE WARNINGS COULD RESULT IN INJURY OR DEATH. CONTACT ANY CATERPILLAR DEALER FOR REPLACEMENT GUIDES. PROPER CARE IS YOUR RESPONSIBILITY.**

TY0001

---

g00107220

 **WARNING**

**DO NOT OPERATE OR WORK ON THIS MACHINE UNLESS YOU HAVE READ AND UNDERSTAND THE INSTRUCTIONS AND WARNINGS IN THE OPERATION AND MAINTENANCE MANUALS. FAILURE TO FOLLOW THE INSTRUCTIONS OR HEED THE WARNINGS COULD RESULT IN INJURY OR DEATH. CONTACT ANY CATERPILLAR DEALER FOR REPLACEMENT MANUALS. PROPER CARE IS YOUR RESPONSIBILITY.**

---

**Height And Reach Of Machine**

---

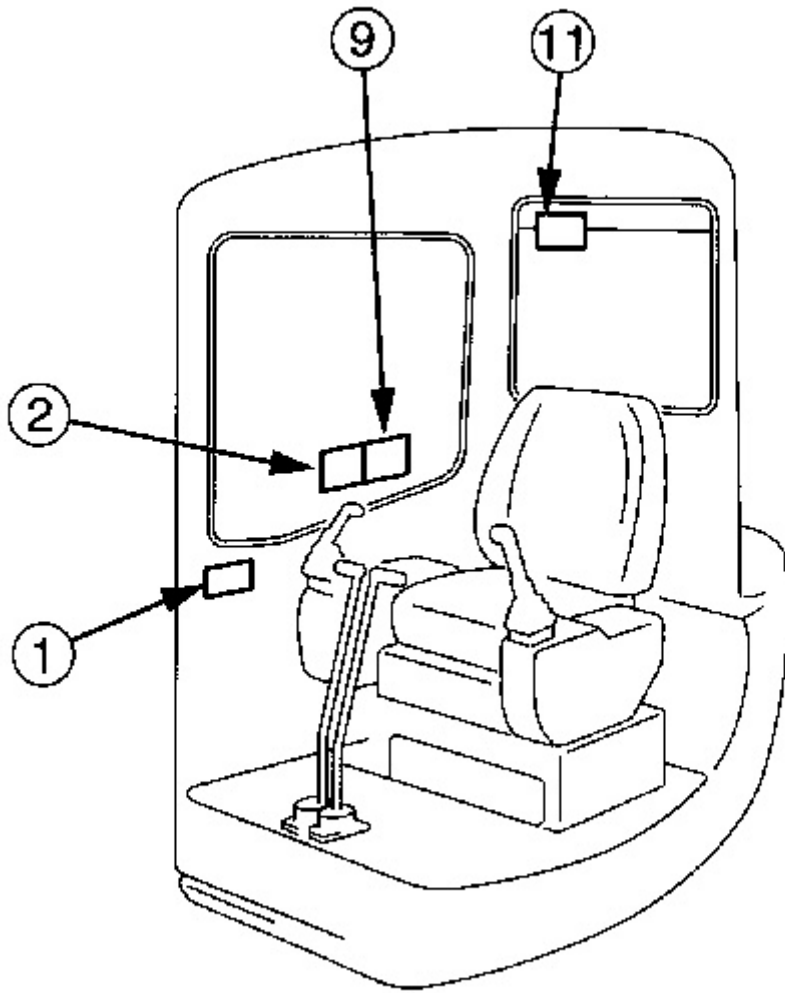

---

Illustration 2

g00661164

This warning label (2) is positioned in the cab.

---



 **WARNING**

**KNOW THE MAXIMUM HEIGHT AND REACH OF YOUR MACHINE**  
**SERIOUS INJURY OR DEATH BY ELECTROCUTION CAN OCCUR IF MACHINE OR ATTACHMENTS ARE NOT KEPT A SAFE DISTANCE FROM ELECTRICAL POWER LINES. KEEP DISTANCE AT LEAST 3 M (10 FEET) PLUS ADDITIONAL 10 MM (0.4 INCH) FOR EACH 1,000 VOLTS OVER 50,000 VOLTS.**

7Y0003 2

---

g00100702

 **WARNING**

**Know the maximum height and reach of your machine. Serious injury or death by electrocution can occur if machine, work tools, or attachments are not kept a safe distance from electrical power lines. Keep distance at least 3 m (10 ft) Plus additional 10 mm (.4 inch) for each 1,000 volts over 50,000 volts.**

---

**Improper Connections For Jump Start Cables**

---

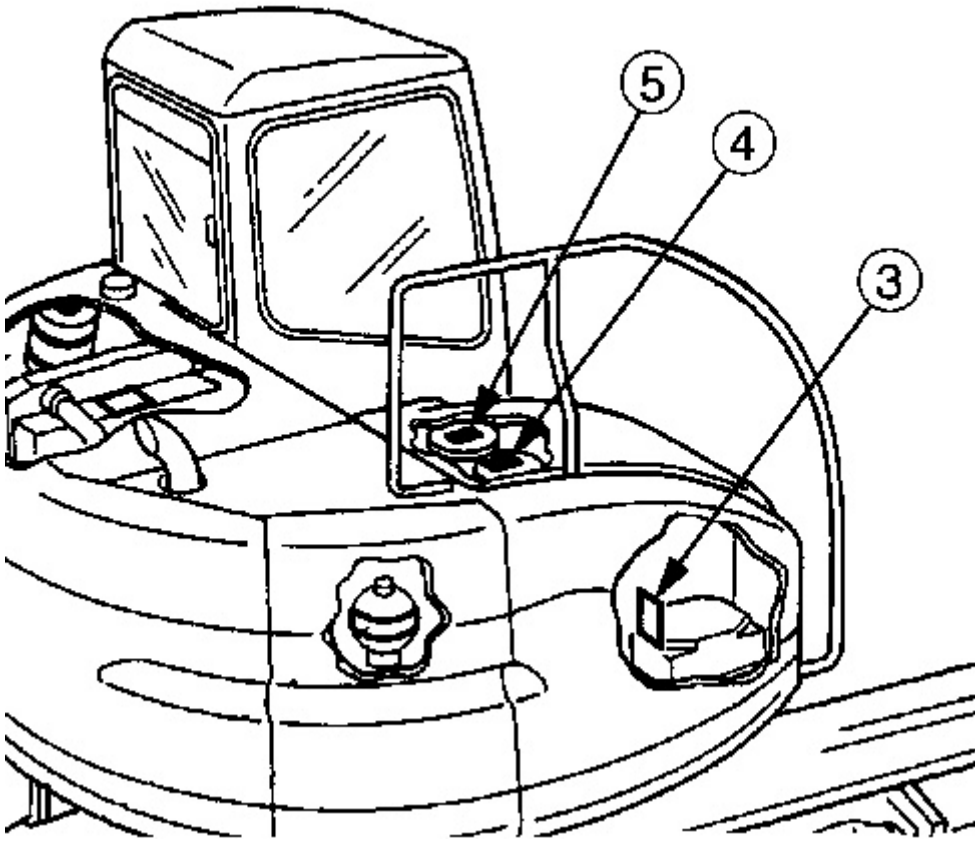

---

Illustration 3

g00661191

This warning label (3) is positioned in the battery compartment.

---

 **WARNING**

**IMPROPER JUMPER CABLE CONNECTIONS CAN CAUSE EXPLOSION RESULTING IN PERSONAL INJURY.**

**BATTERIES MAY BE LOCATED IN SEPARATE COMPARTMENTS. WHEN USING JUMPER CABLES, ALWAYS CONNECT POSITIVE ( + ) CABLE TO POSITIVE ( + ) TERMINAL OF BATTERY CONNECTED TO STARTER SOLENOID AND NEGATIVE ( - ) CABLE FROM EXTERNAL SOURCE TO STARTER NEGATIVE ( - ) TERMINAL (IF MACHINE NOT EQUIPPED WITH STARTER NEGATIVE TERMINAL, CONNECT TO ENGINE BLOCK.) FOLLOW PROCEDURE IN THE OPERATION MANUAL.**

5V-4611 4

g00038786

 **WARNING**

**IMPROPER JUMPER CABLE CONNECTIONS CAN CAUSE EXPLOSION RESULTING IN PERSONAL INJURY.**

**BATTERIES MAY BE LOCATED IN SEPARATE COMPARTMENTS. WHEN USING JUMPER CABLES, ALWAYS CONNECT POSITIVE ( + ) CABLE TO POSITIVE ( + ) TERMINAL OF BATTERY CONNECTED TO STARTER SOLENOID AND NEGATIVE ( - ) CABLE FROM EXTERNAL SOURCE TO STARTER**

**NEGATIVE (-) TERMINAL (IF MACHINE NOT EQUIPPED WITH STARTER NEGATIVE TERMINAL, CONNECT TO ENGINE BLOCK.) FOLLOW PROCEDURE IN THE OPERATION MANUAL.**

---

### Relieve Hydraulic Tank Pressure

---

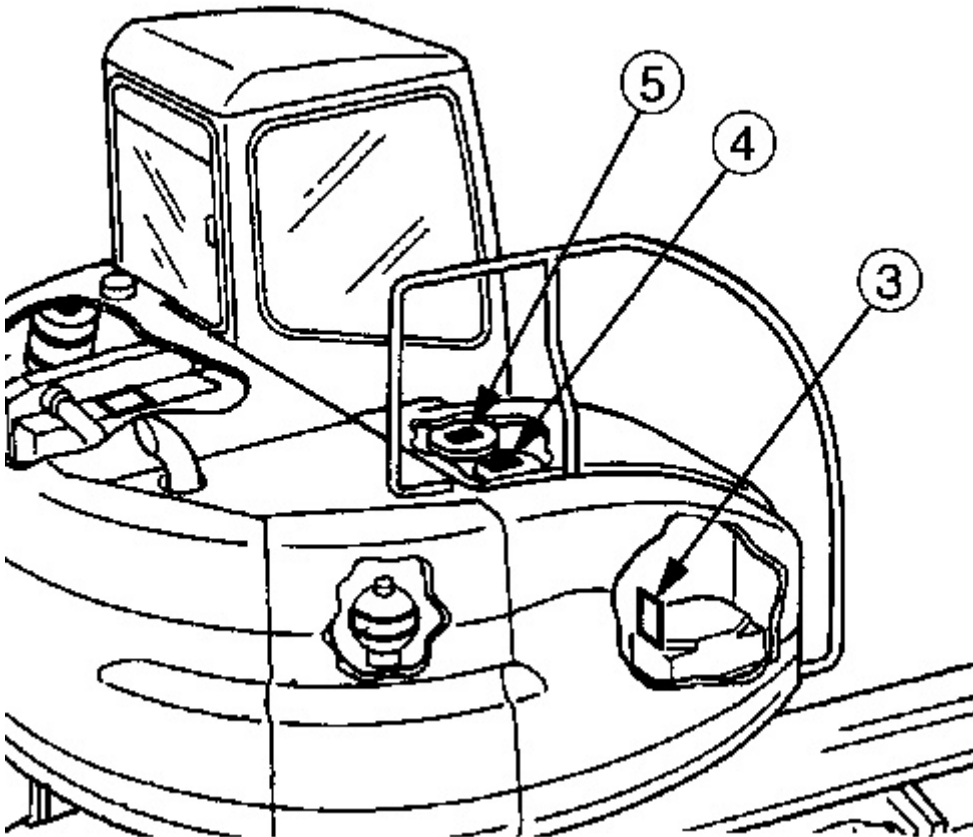

Illustration 4

g00661191

This warning label (4) is located on the top of the hydraulic tank.

---

**! WARNING**

**HYDRAULIC TANK**

**RELIEVE TANK PRESSURE WITH ENGINE OFF BY REMOVING CAP SLOWLY TO PREVENT BURNS FROM HOT OIL.**

7Y0013 1

g00100722

**! WARNING**

**HYDRAULIC TANK**

**RELIEVE TANK PRESSURE WITH ENGINE OFF BY REMOVING CAP SLOWLY TO PREVENT BURNS FROM HOT OIL.**

**Lift Eyes Can Fail**

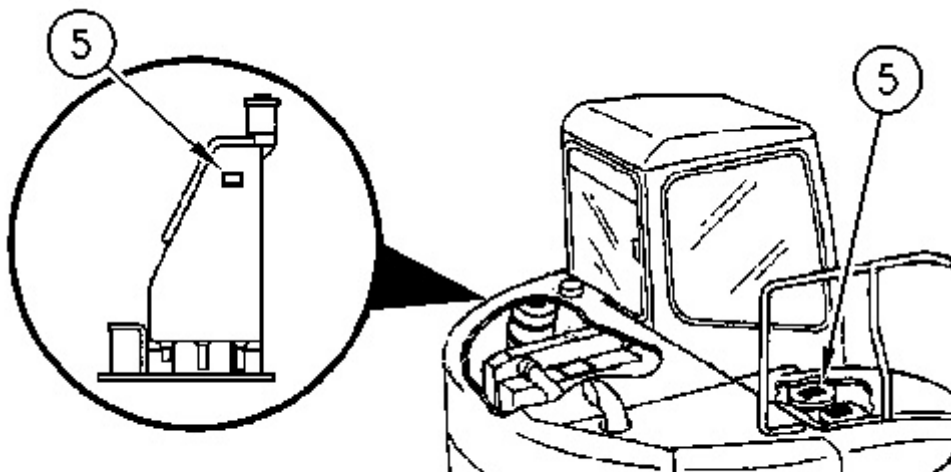

This warning label (5) is positioned on the hydraulic tank and on the side of the fuel tank.

---

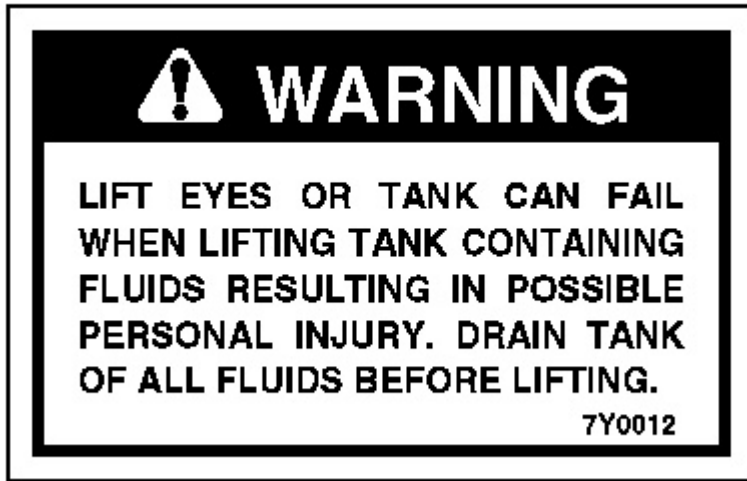

---

g00100728



**LIFT EYES OR TANK CAN FAIL WHEN LIFTING TANK CONTAINING FLUIDS RESULTING IN POSSIBLE PERSONAL INJURY. DRAIN TANK OF ALL FLUIDS BEFORE LIFTING.**

---

**High Pressure Gas**

---

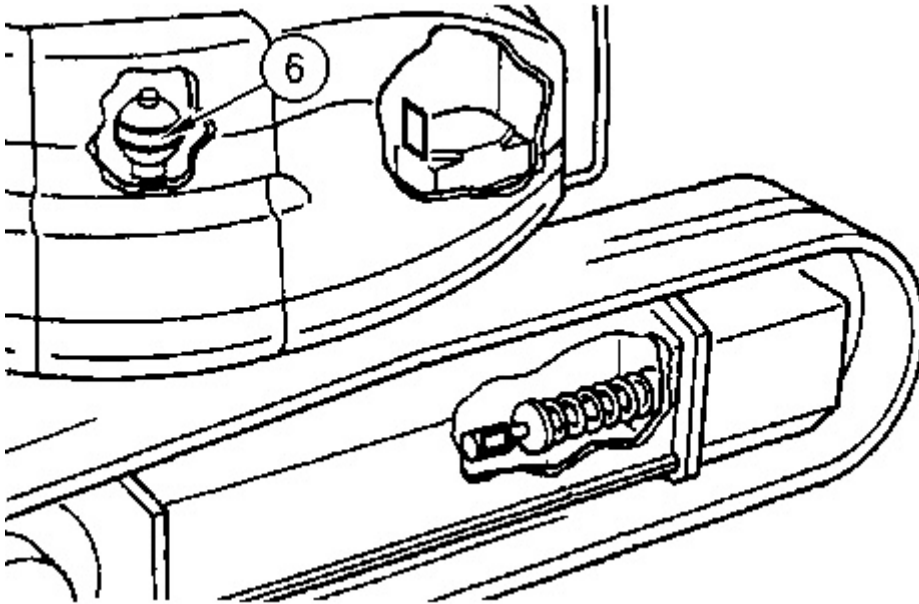

Illustration 6

g00661267

This warning label (6) is positioned on the accumulator.



g00100733



**CONTAINS HIGH PRESSURE GAS**

**TO AVOID EXPLOSION AND PERSONAL INJURY, DO NOT EXPOSE TO FIRE, DO NOT WELD, DO NOT DRILL. RELIEVE PRESSURE BEFORE DISCHARGING.**

**SEE OPERATION & MAINTENANCE MANUAL FOR CHARGING AND DISCHARGING. SEE YOUR CATERPILLAR DEALER FOR TOOLS AND DETAILED INFORMATION.**

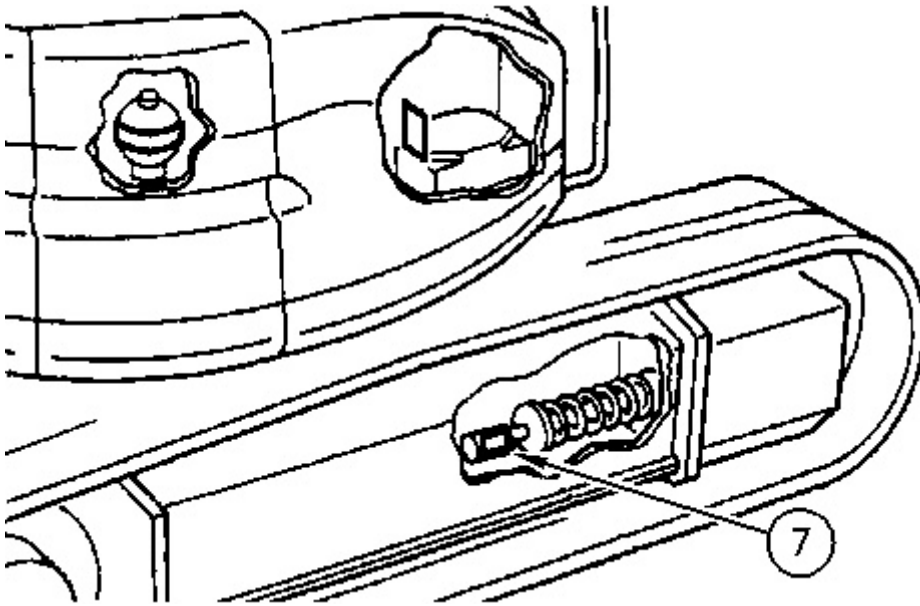

Illustration 7

g00667078

This warning label (7) is positioned on the track adjuster.

---



g00100742

## HIGH PRESSURE CYLINDER

Do not remove any parts until all of the pressure has been relieved. This will avoid possible personal injury. The knob can be rotated to a maximum of one turn.

See the Operation and Maintenance Manual, "Track Adjustment - Adjust" information for your product.



## No Ether

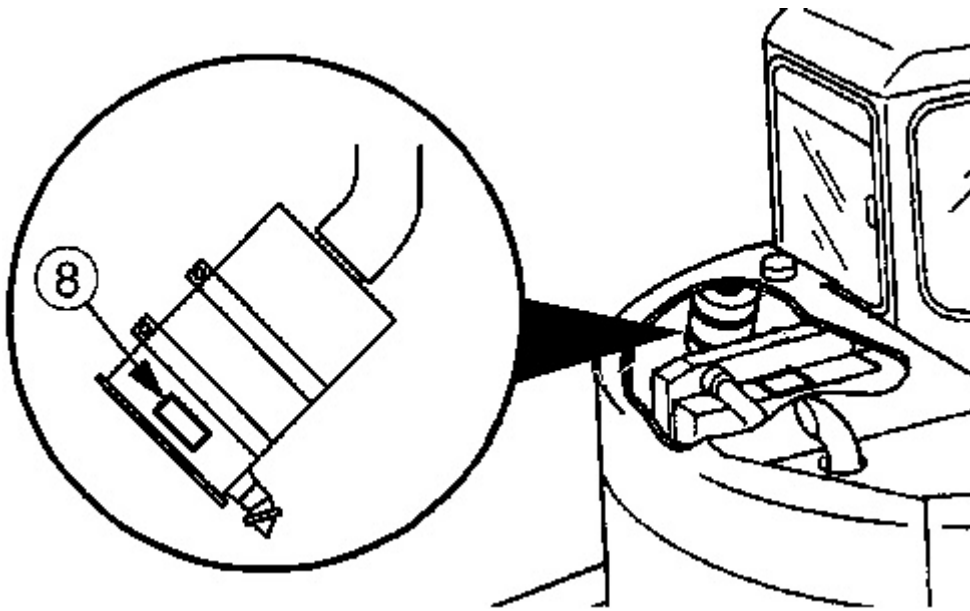

Illustration 8

g00661298

This warning label (8) is positioned on the air cleaner.

---



g00100745

## NO ETHER

Do not spray ether into the air intake. This machine is equipped with glow plugs. Severe injury or death may occur from an explosion.

## Travel Speed Control Pedal

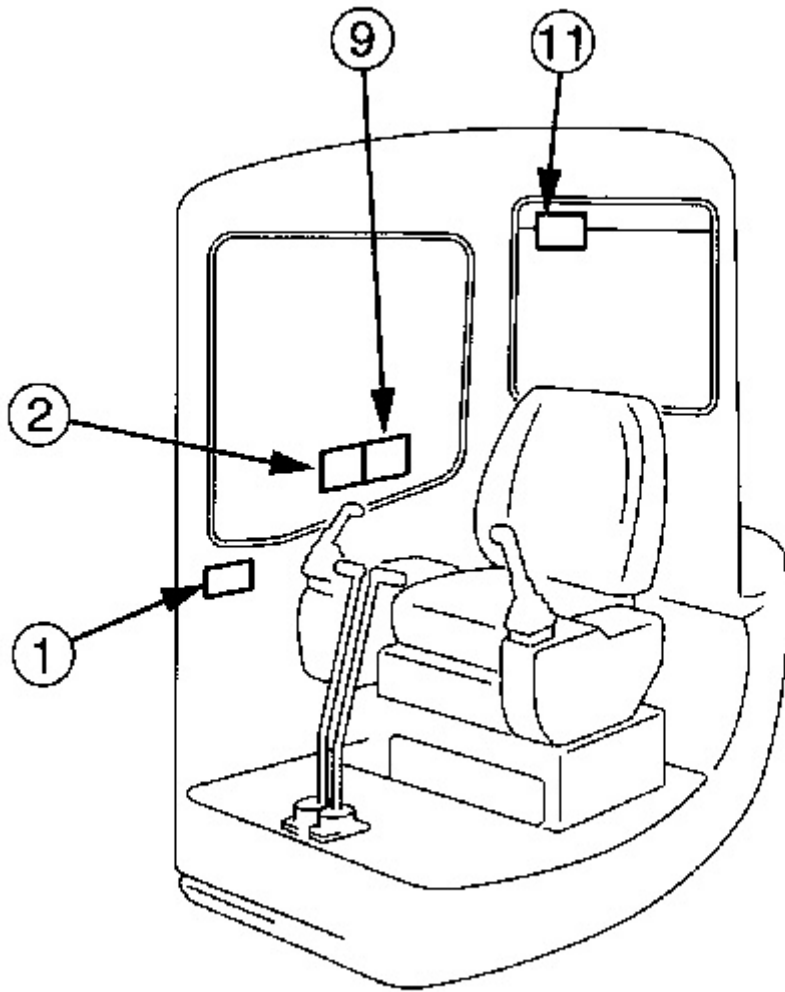

---

Illustration 9

g00661164

This warning label (9) is positioned in the cab.

---

 **WARNING**

**DO NOT ENGAGE TRAVEL SPEED CONTROL PEDAL BEFORE DESCENDING A SLOPE OR LOADING OR UNLOADING ON TRAILER. IF TRAVEL SPEED CONTROL PEDAL IS ENGAGED DURING THESE OPERATIONS, SUDDEN CHANGES IN MACHINE SPEED CAN OCCUR WITH AN ADVERSE EFFECT ON MACHINE CONTROL, RESULTING IN PERSONAL INJURY.**

169-8101

---

g00667151

 **WARNING**

**DO NOT ENGAGE TRAVEL SPEED CONTROL PEDAL BEFORE DESCENDING A SLOPE OR LOADING OR UNLOADING ON TRAILER. IF TRAVEL SPEED CONTROL PEDAL IS ENGAGED DURING THESE OPERATIONS, SUDDEN CHANGES IN MACHINE SPEED CAN OCCUR WITH AN ADVERSE EFFECT ON MACHINE CONTROL, RESULTING IN PERSONAL INJURY.**

---

Pressurized System

---

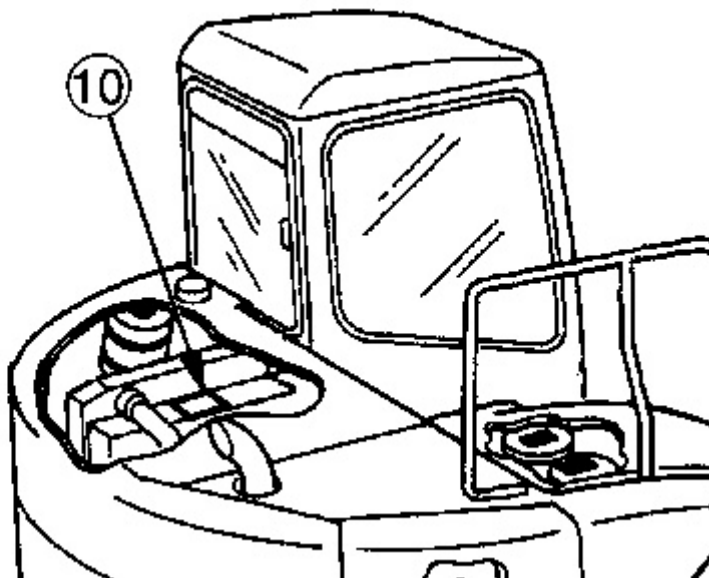
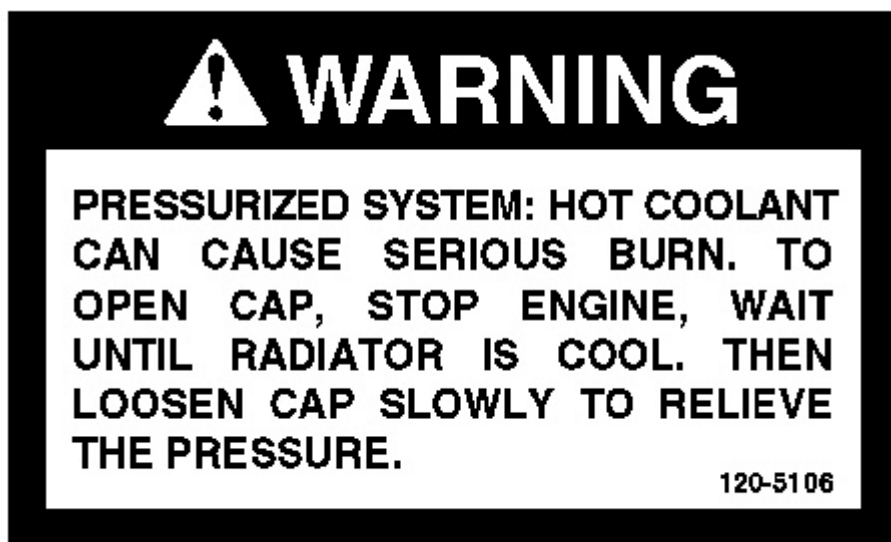

Illustration 10

g00661311

This warning label (10) is positioned on the radiator.



g00100763



**PRESSURIZED SYSTEM: HOT COOLANT CAN CAUSE SERIOUS BURN. TO OPEN CAP, STOP ENGINE, WAIT UNTIL RADIATOR IS COOL. THEN LOOSEN CAP SLOWLY TO RELIEVE THE PRESSURE.**

---

## The Upper Windshield Slides Downward

---

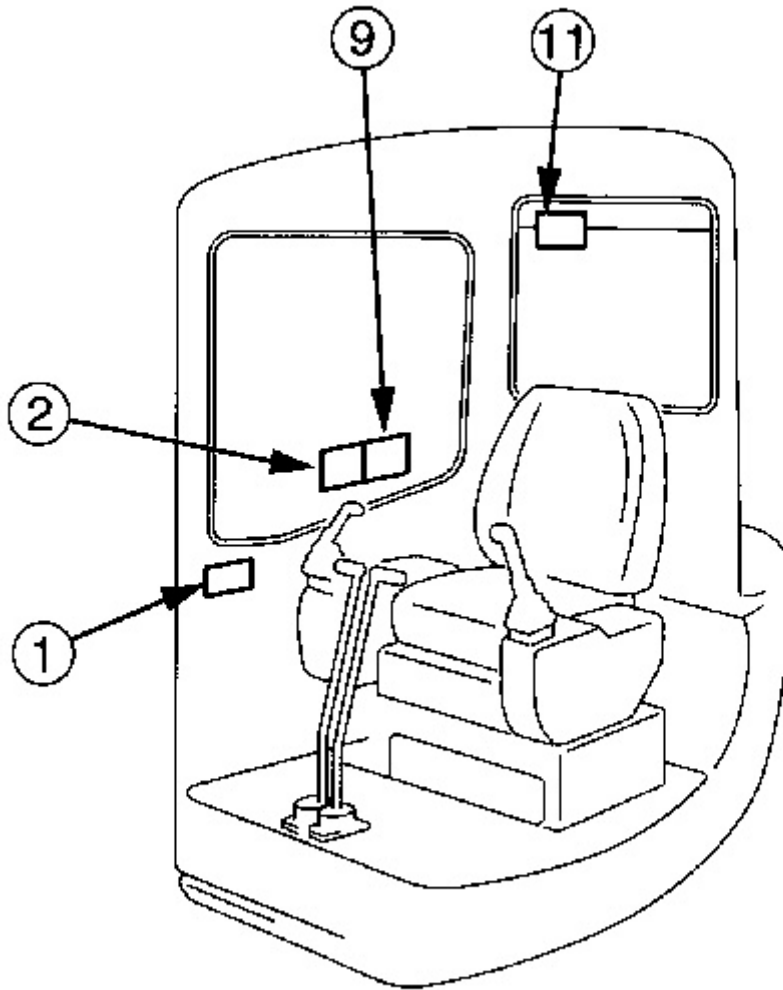

---

Illustration 11

g00661164

This warning label (11) is positioned in the cab.

---

# **WARNING**

**PERSONAL INJURY CAN RESULT IF THE UPPER WINDSHIELD SLIDES DOWN. WHEN OPENING THE UPPER WINDSHIELD,**

- **ENSURE THE AUTO LOCK LATCH (2) IS ENGAGED, AND**
- **MOVE THE LEVERS OF THE MANUAL LOCK LATCHES (1) AT BOTH SIDES OF THE WINDSHIELD TO THE LOCKED POSITION AND PUSH THE LOCK LEVERS TOWARD THE REAR OF CAB TO SECURELY HOLD THE WINDSHIELD IN THE STORAGE POSITION.**

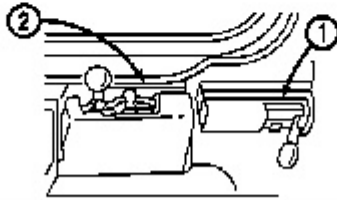

134-6144

---

g00104653

# **WARNING**

**PERSONAL INJURY CAN RESULT IF THE UPPER WINDSHIELD SLIDES DOWN. WHEN OPENING THE UPPER WINDSHIELD,**

- **ENSURE THE AUTO LOCK LATCH (2) IS ENGAGED, AND**
  - **MOVE THE LEVERS OF THE MANUAL LOCK LATCHES (1) AT BOTH SIDES OF THE WINDSHIELD TO THE LOCKED POSITION AND PUSH THE LOCK LEVERS TOWARD THE REAR OF CAB TO SECURELY HOLD THE WINDSHIELD IN THE STORAGE POSITION.**
-

Thank you so much for reading.  
Please click the “Buy Now!”  
button below to download the  
complete manual.



After you pay.

You can download the most  
perfect and complete manual in  
the world immediately.

Our support email:

[ebooklibonline@outlook.com](mailto:ebooklibonline@outlook.com)