

Product: EXCAVATOR

Model: 320C EXCAVATOR EGA

Configuration: 320C Hydraulic Material Handler EGA00001-UP (MACHINE) POWERED BY 3066 Engine

Operation and Maintenance Manual 320C Material Handler

Media Number -SEBU7670-03

Publication Date -01/08/2004

Date Updated -10/08/2004

s00037320

Foreword

SMCS - 7606

Literature Information

This manual should be stored in the operator's compartment in the literature holder or seat back literature storage area.

This manual contains safety information, operation instructions, transportation information, lubrication information and maintenance information.

Some photographs or illustrations in this publication show details or attachments that can be different from your machine. Guards and covers might have been removed for illustrative purposes.

Continuing improvement and advancement of product design might have caused changes to your machine which are not included in this publication. Read, study and keep this manual with the machine.

Whenever a question arises regarding your machine, or this publication, please consult your Cat dealer for the latest available information.

Safety

The safety section lists basic safety precautions. In addition, this section identifies the text and locations of warning signs and labels used on the machine.

Read and understand the basic precautions listed in the safety section before operating or performing lubrication, maintenance and repair on this machine.

Operation

The operation section is a reference for the new operator and a refresher for the experienced operator. This section includes a discussion of gauges, switches, machine controls, attachment controls, transportation and towing information.

Photographs and illustrations guide the operator through correct procedures of checking, starting, operating and stopping the machine.

Operating techniques outlined in this publication are basic. Skill and techniques develop as the operator gains knowledge of the machine and its capabilities.

Maintenance

The maintenance section is a guide to equipment care. The Maintenance Interval Schedule (MIS) lists the items to be maintained at a specific service interval. Items without specific intervals are listed under the "When Required" service interval. The Maintenance Interval Schedule lists the page number for the step-by-step instructions required to accomplish the scheduled maintenance. Use the Maintenance Interval Schedule as an index or "one safe source" for all maintenance procedures.

Maintenance Intervals

Use the service hour meter to determine servicing intervals. Calendar intervals shown (daily, weekly, monthly, etc.) can be used instead of service hour meter intervals if they provide more convenient servicing schedules and approximate the indicated service hour meter reading. Recommended service should always be performed at the interval that occurs first.

Under extremely severe, dusty or wet operating conditions, more frequent lubrication than is specified in the maintenance intervals chart might be necessary.

Perform service on items at multiples of the original requirement. For example, at every 500 service hours or 3 months, also service those items listed under every 250 service hours or monthly and every 10 service hours or daily.

California Proposition 65 Warning

Diesel engine exhaust and some of its constituents are known to the State of California to cause cancer, birth defects, and other reproductive harm.

Battery posts, terminals and related accessories contain lead and lead compounds. **Wash hands after handling.**

Certified Engine Maintenance

Proper maintenance and repair is essential to keep the engine and machine systems operating correctly. As the heavy duty off-road diesel engine owner, you are responsible for the performance of the required maintenance listed in the Owner Manual, Operation and Maintenance Manual, and Service Manual.

It is prohibited for any person engaged in the business of repairing, servicing, selling, leasing, or trading engines or machines to remove, alter, or render inoperative any emission related device or element of design installed on or in an engine or machine that is in compliance with the

regulations (40 CFR Part 89). Certain elements of the machine and engine such as the exhaust system, fuel system, electrical system, intake air system and cooling system may be emission related and should not be altered unless approved by Caterpillar.

Machine Capacity

Additional attachments or modifications may exceed machine design capacity which can adversely affect performance characteristics. Included would be stability and system certifications such as brakes, steering, and rollover protective structures (ROPS). Contact your Cat dealer for further information.

Cat Product Identification Number

Effective First Quarter 2001 the Cat Product Identification Number (PIN) has changed from 8 to 17 characters. In an effort to provide uniform equipment identification, Caterpillar and other construction equipment manufacturers are moving to comply with the latest version of the product identification numbering standard. Non-road machine PINs are defined by ISO 10261. The new PIN format will apply to all Cat machines and generator sets. The PIN plates and frame marking will display the 17 character PIN. The new format will look like the following:



Illustration 1

g00751314

Where:

1. Caterpillar's World Manufacturing Code (characters 1-3)
2. Machine Descriptor (characters 4-8)
3. Check Character (character 9)
4. Machine Indicator Section (MIS) or Product Sequence Number (characters 10-17). These were previously referred to as the Serial Number.

Machines and generator sets produced before First Quarter 2001 will maintain their 8 character PIN format.

Components such as engines, transmissions, axles, etc. and work tools will continue to use an 8 character Serial Number (S/N).

Product: EXCAVATOR

Model: 320C EXCAVATOR EGA

Configuration: 320C Hydraulic Material Handler EGA00001-UP (MACHINE) POWERED BY 3066 Engine

Operation and Maintenance Manual 320C Material Handler

Media Number -SEBU7670-03

Publication Date -01/08/2004

Date Updated -10/08/2004

i02164209

Safety Messages - Arrangement I

SMCS - 7000; 7405

S/N - EGA1-304

S/N - JPL1-UP

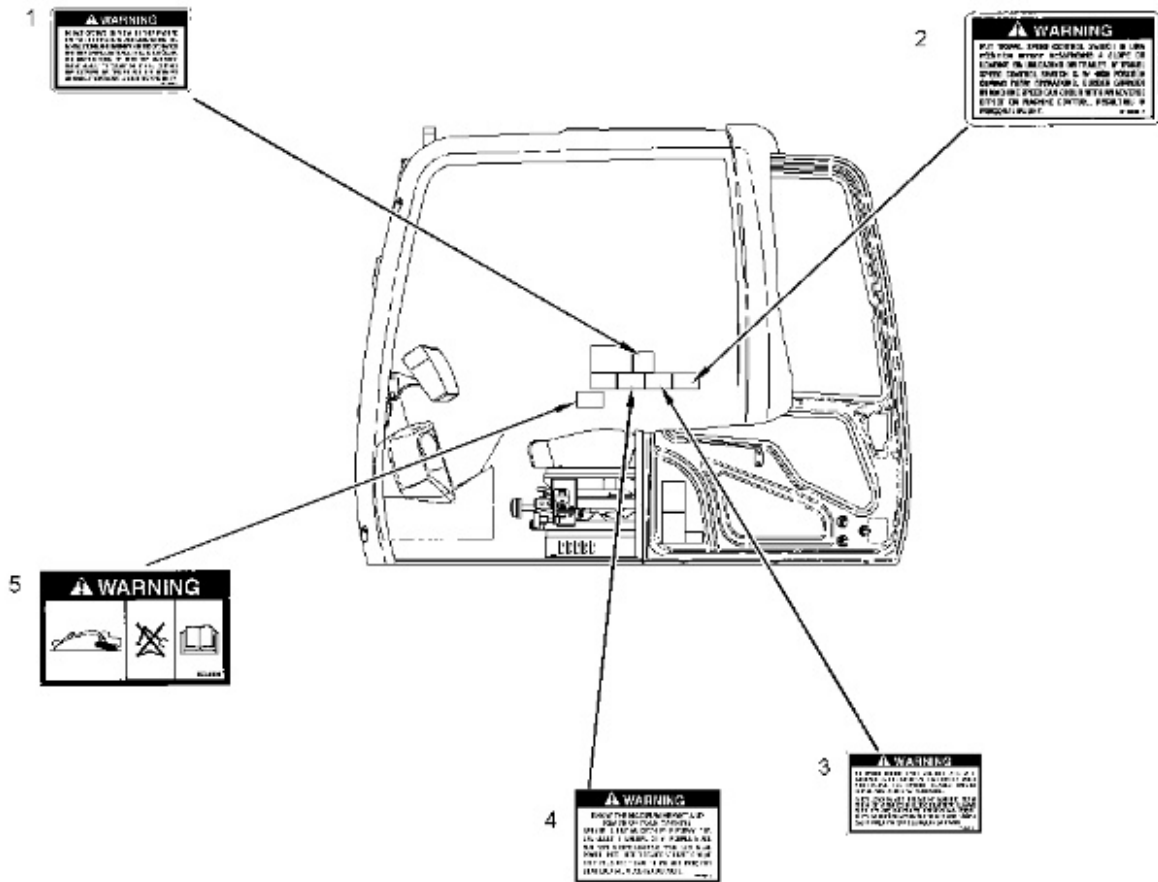

Illustration 2

g01057783

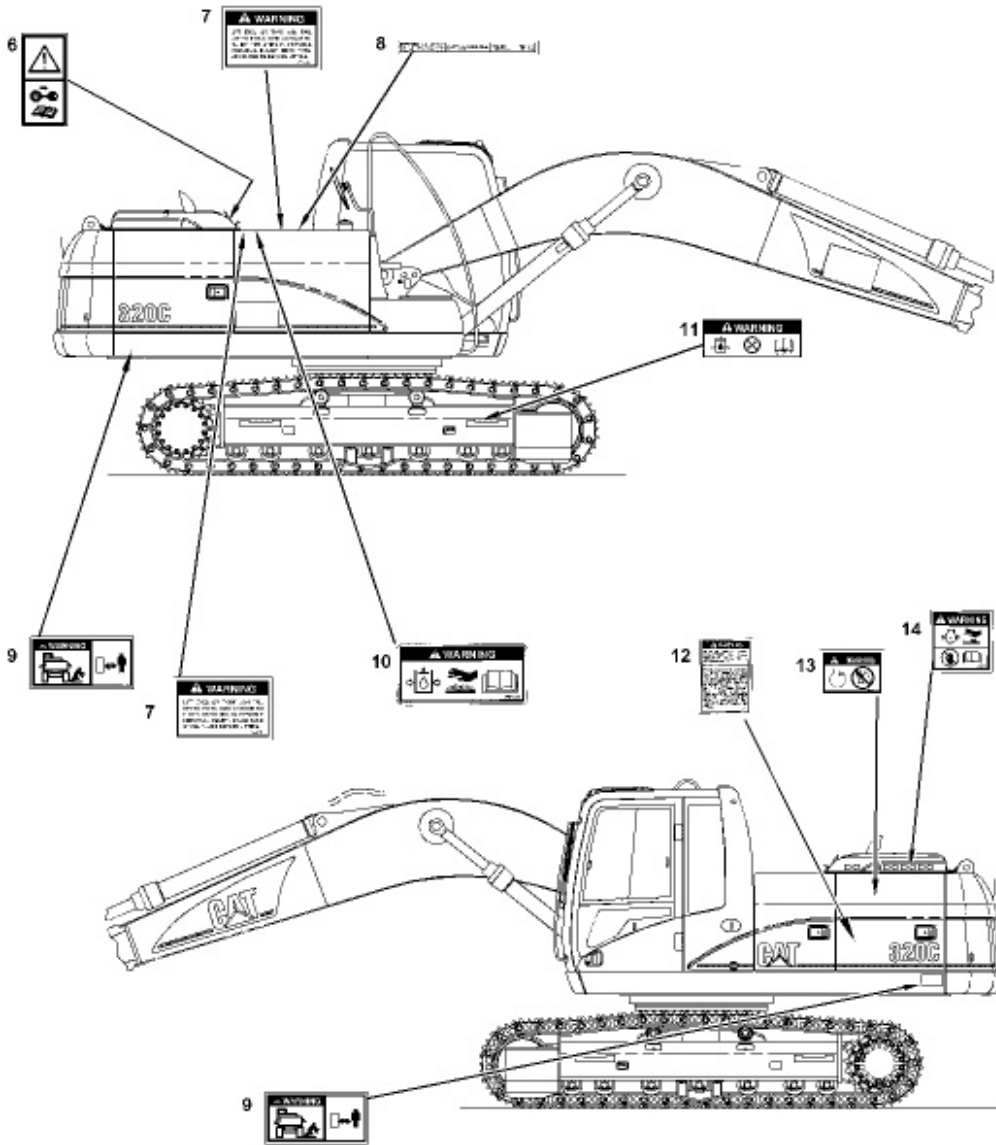

Illustration 3

g01057586

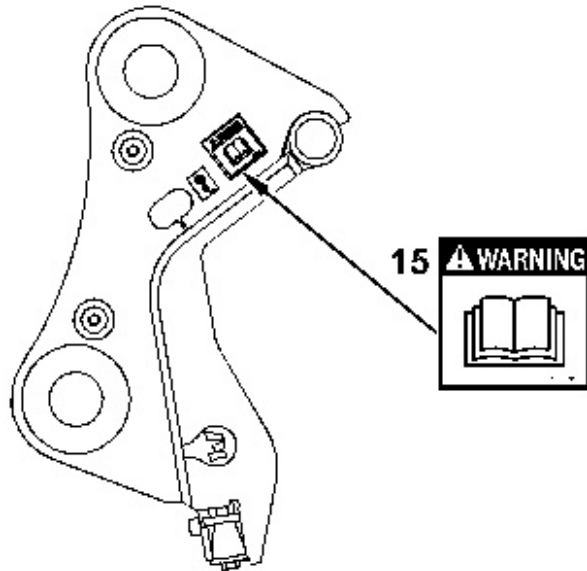

Illustration 4

g01057464

There are several specific safety messages on this machine. The exact location of the messages and the description of the messages are reviewed in this section. Please become familiarized with all safety messages.

Make sure that all of the safety messages are legible. Clean the safety messages or replace the safety messages if you cannot read the words. Replace the illustrations if the illustrations are not legible. When you clean the safety messages, use a cloth, water and soap. Do not use solvent, gasoline, or other harsh chemicals to clean the safety messages. Solvents, gasoline, or harsh chemicals could loosen the adhesive that secures the safety message. Loose adhesive will allow the safety message to fall.

Replace any safety message that is damaged, or missing. If a safety message is attached to a part that is replaced, attach a safety message on the replacement part. Any Caterpillar dealer can provide new safety messages.

Do Not Operate (1)

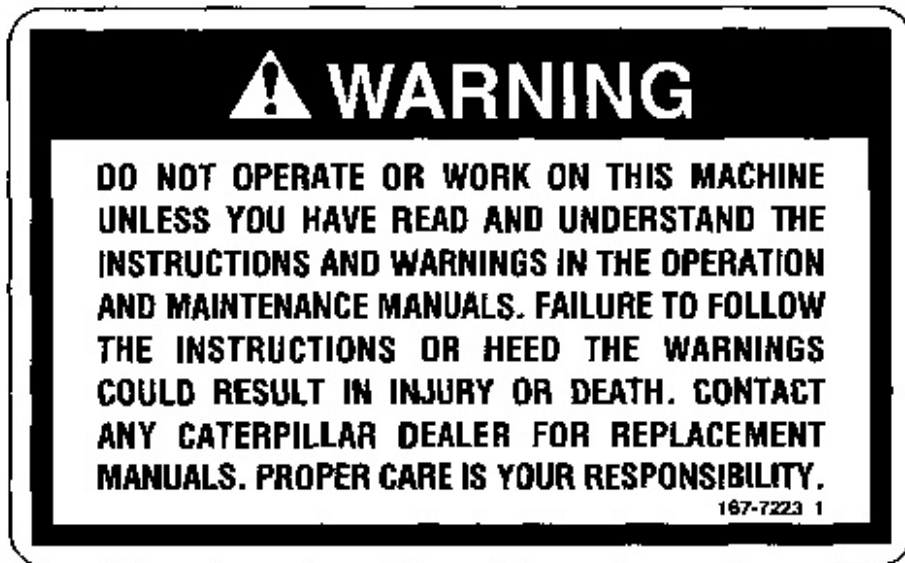

Illustration 5

g00684449

This safety message is positioned on the right side of the cab.



Travel Speed Control Switch (2)

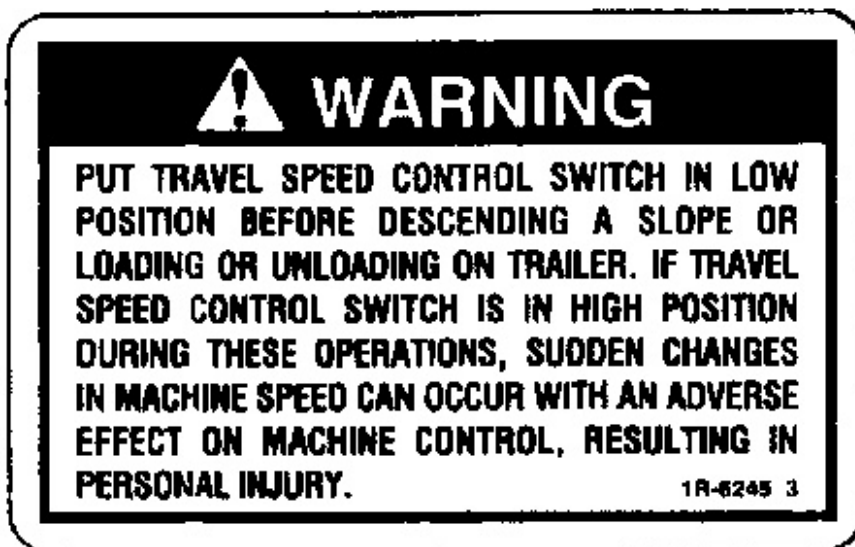

This safety message is positioned in the cab.



Put travel speed control switch in LOW position before descending a slope or loading or unloading on trailer. If travel speed control switch is in HIGH position during these operations, sudden changes in machine speed can occur with an adverse effect on machine control, resulting in personal injury.

Automatic Engine Speed Control (AEC) (3)

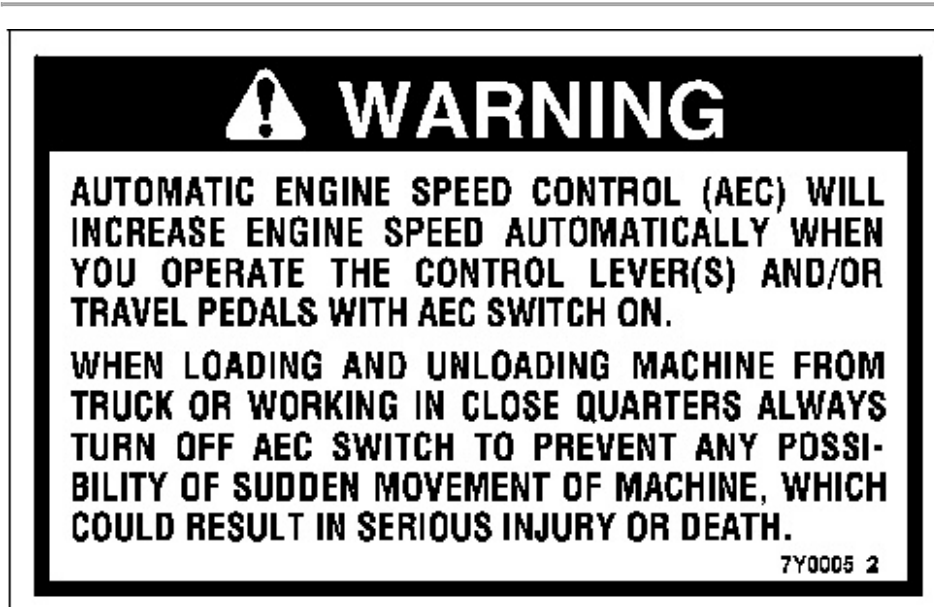

This safety message is positioned in the cab.



Automatic Engine Speed Control (AEC) will increase engine speed automatically when you operate the control lever(s) and/or travel pedals when in position TWO.

When loading and unloading machine from truck or working in close quarters, always have AEC switch in position ONE to prevent any

possibility of sudden movement of machine, which could result in serious injury or death.

Height and Reach of Machine (4)

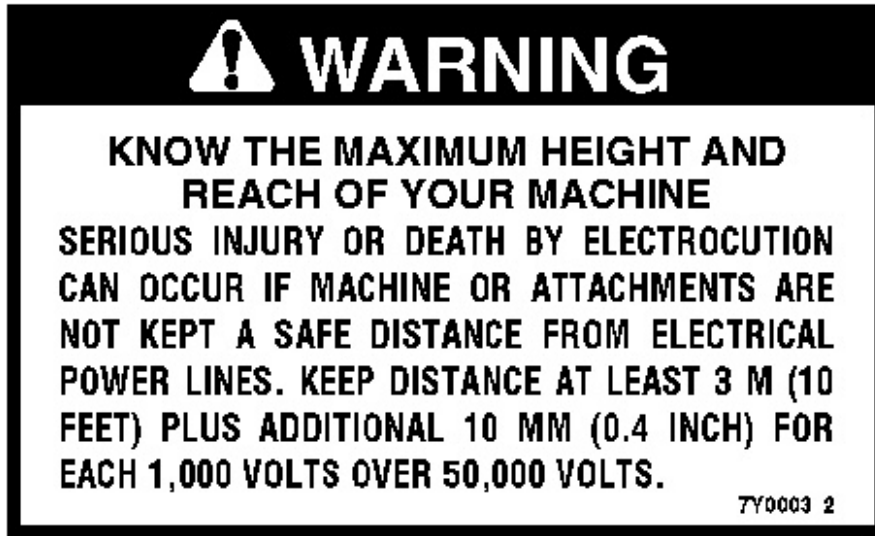

Illustration 8

g00100702

This safety message is positioned in the cab.



Smart Boom (5)

This safety message is positioned in the cab.



g00810639

 **WARNING**

Do not elevate or lower the track when in the SmartBoom mode. Follow the operation procedures for the SmartBoom in the Operation and Maintenance Manual. Failure to follow these instructions can result in serious injury or death.

Maintenance (6)

This message is located on the platform at the center of the machine.

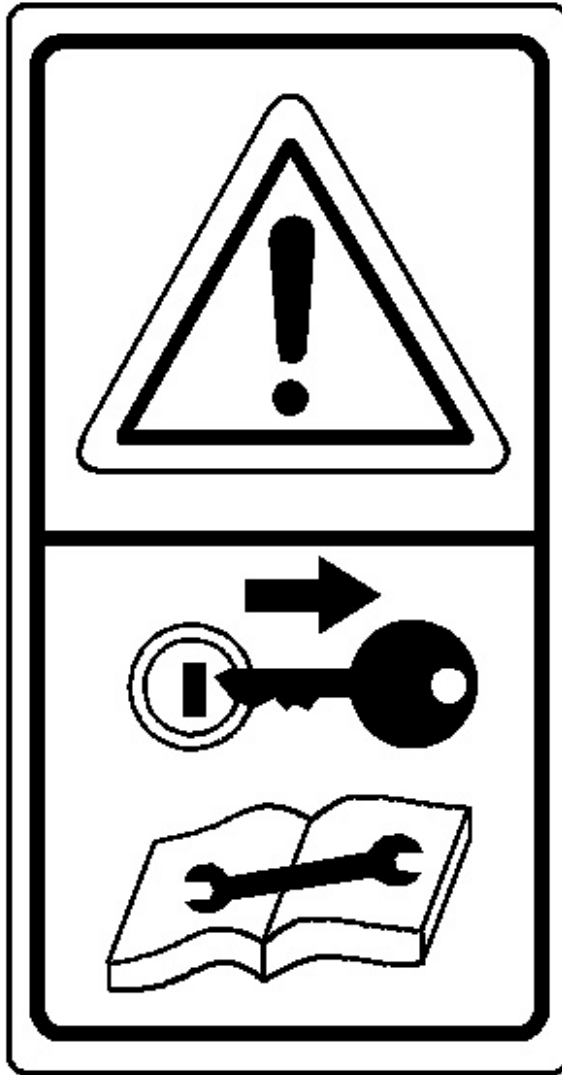

g00992807

 **WARNING**

Shut off engine and remove key before performing maintenance or repair work. Failure to do so may result in personal injury due to inadvertant machine operation.

Do not start the engine or move any of the controls if there is a "Do Not Operate" or similar warning tag attached to the start switch or controls.

Lift Eyes Can Fail (7)

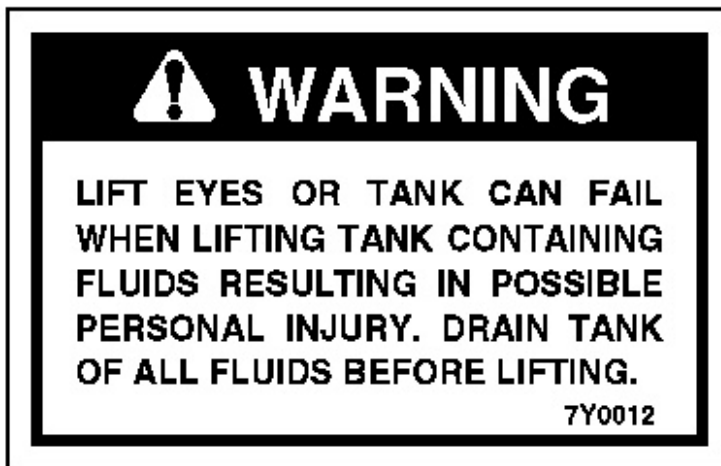
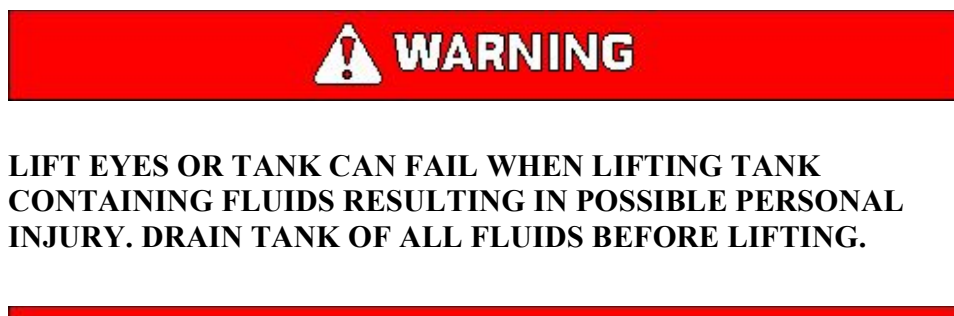

Illustration 9

g00100728

This safety message is located on the top of the hydraulic tank and on top of the fuel tank.



High Pressure Gas (8)



Illustration 10

g00100733

This safety message is positioned on the accumulator.



This system contains high pressure gas. Failure to follow the instructions and warnings could cause an explosion, resulting in possible injury or death.

Do not expose to fire. Do not weld. Do not drill. Relieve pressure before discharging.

See Operation and Maintenance Manual for charging and discharging. See your Caterpillar Dealer for tools and detailed information.

Machine Swings (9)



Illustration 11

g00750340

This safety message is located in two places on the rear of each side of the machine.



Machine swings. Stay back. Crushing hazard could cause serious injury or death.

Relieve Hydraulic Tank Pressure (10)

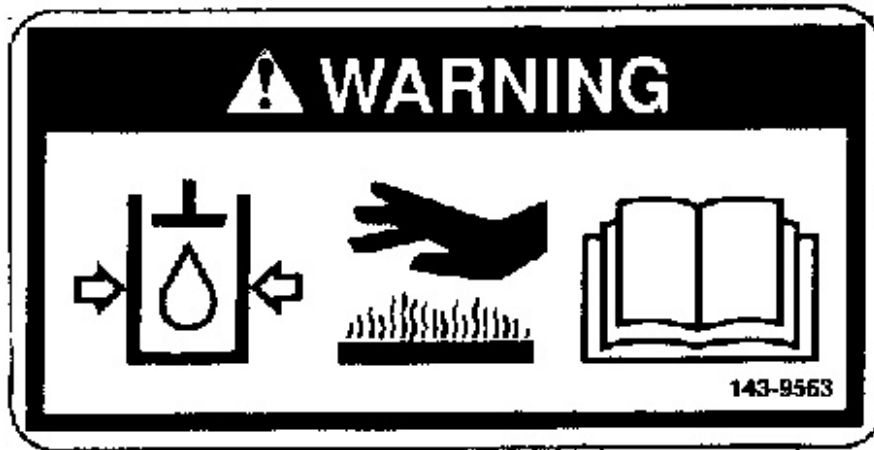

Illustration 12

g00912819

This safety message is located on top of the hydraulic tank.



High Pressure Cylinder (11)

This safety message is located on the track adjuster.



⚠ WARNING

High Pressure Cylinder. Do not remove any parts from the cylinder until all of the pressure has been relieved. This will prevent possible personal injury or death.

Improper Connections for Jump Start Cables (12)

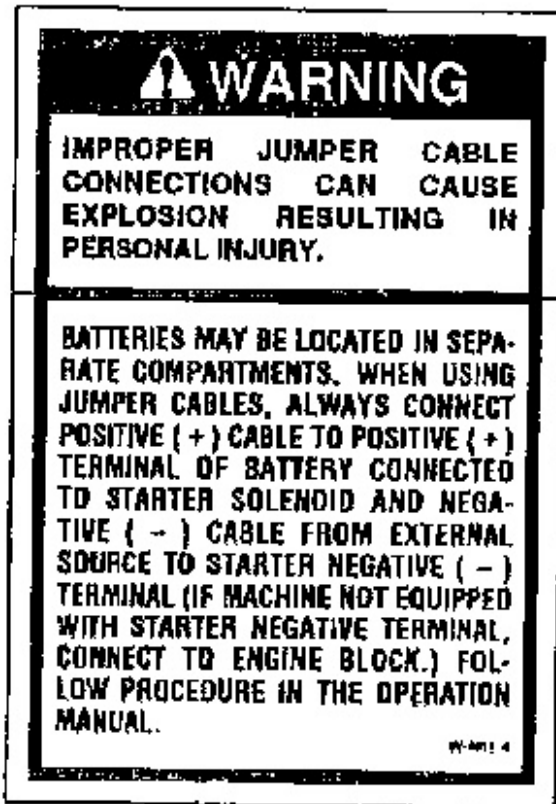

Illustration 13

This safety message is positioned on the circuit breaker panel.

⚠ WARNING

IMPROPER JUMPER CABLE CONNECTIONS CAN CAUSE EXPLOSION RESULTING IN PERSONAL INJURY.

BATTERIES MAY BE LOCATED IN SEPARATE COMPARTMENTS. WHEN USING JUMPER CABLES, ALWAYS CONNECT POSITIVE (+) CABLE TO POSITIVE (+) TERMINAL OF BATTERY CONNECTED TO STARTER SOLENOID AND NEGATIVE (-) CABLE FROM EXTERNAL SOURCE TO STARTER NEGATIVE (-) TERMINAL (IF MACHINE NOT EQUIPPED WITH STARTER NEGATIVE TERMINAL, CONNECT TO ENGINE BLOCK.) FOLLOW PROCEDURE IN THE OPERATION MANUAL.

No Ether (13)



Illustration 14

g00912750

This safety message is positioned on the cover of the intake duct of the air cleaner. The following information is not applicable to machines that are equipped with an ether starting aid.

! WARNING

Since this machine is equipped with an air inlet heater, ether should not be used for starting. Using ether can create explosions or fires that can cause personal injury or death. Follow the starting procedure in the Operation and Maintenance Manual.

Pressurized System (14)



Illustration 15

g00768931

This safety message is located inside the engine compartment next to the cooling system filler cap.



Pressurized system: Hot coolant can cause serious burn. To open cap, stop engine, wait until radiator is cool. Then loosen cap slowly to relieve the pressure.

Quick Coupler (15)

This safety message is located on each side of the quick coupler.



g00984073



Do not operate or work on this machine or work tool unless you have read and understand the instructions and warnings in the Operation and Maintenance Manuals and Owner's Manuals. Failure to follow the instructions or heed the warnings could result in injury or death. Contact your Caterpillar dealer for replacement manuals. Proper care is your responsibility.

Thank you so much for reading.
Please click the “Buy Now!”
button below to download the
complete manual.



After you pay.

You can download the most
perfect and complete manual in
the world immediately.

Our support email:

ebooklibonline@outlook.com