

Previous Screen

Product: BACKHOE LOADER

Model: 436C BACKHOE LOADER 1PR

Configuration: 436C Backhoe Loader Center Pivot, Parallel Lift 1PR01599-01815 (MACHINE) POWERED BY 3054 Engine

Operation and Maintenance Manual
416C, 426C, 428C, 436C and 438C Backhoe Loaders

Media Number -SEBU6873-05

Publication Date -01/07/2008

Date Updated -14/07/2008

i03150003

Safety Messages

SMCS - 7000; 7405

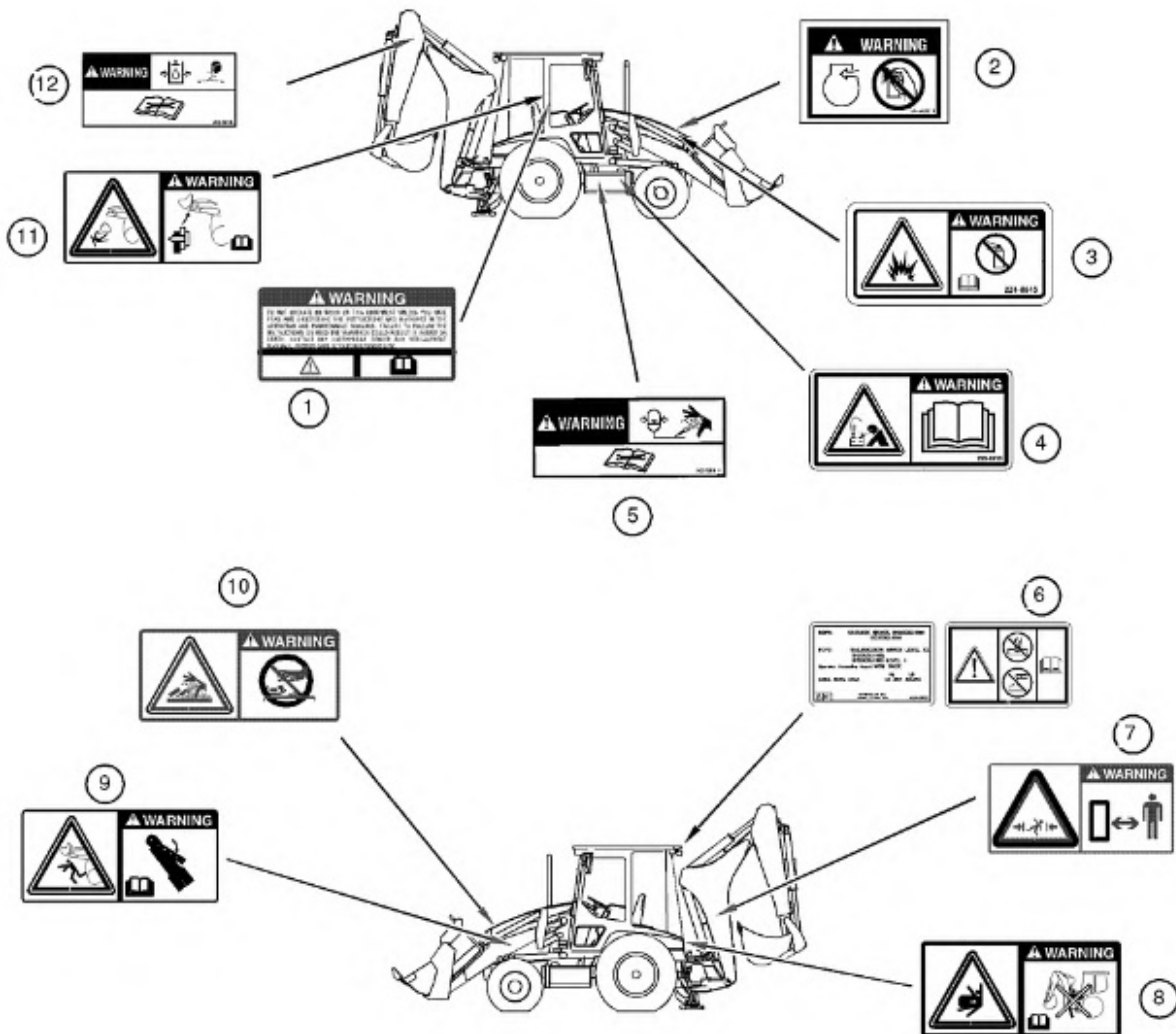

There are several specific safety messages on this machine. The exact location of the hazards and the description of the hazards are reviewed in this section. Please become familiarized with all safety messages.

Make sure that all of the safety messages are legible. Clean the safety messages or replace the safety messages if you cannot read the words. Replace the illustrations if the illustrations are not legible. When you clean the safety messages, use a cloth, water and soap. Do not use solvent, gasoline, or other harsh chemicals to clean the safety messages. Solvents, gasoline, or harsh chemicals could loosen the adhesive that secures the safety message. Loose adhesive will allow the safety message to fall.

Replace any safety message that is damaged, or missing. If a safety message is attached to a part that is replaced, install a safety message on the replacement part. Any Caterpillar dealer can provide new safety messages.

Do Not Operate (1)



Illustration 2

g00930652

This safety message is located above the right side console.



Do not operate or work on this machine unless you have read and understand the instructions and warnings in the Operation and Maintenance Manuals. Failure to follow the instructions or heed the warnings could result in injury or death. Contact your Caterpillar dealer for replacement manuals. Proper care is your responsibility.

No Ether In Air Inlet (2)



Illustration 3

g00924889

This safety message is located on the valve cover.



If equipped with an air inlet heater (AIH) for cold weather starting, do not use aerosol types of starting aids such as ether. Such use could result in an explosion and personal injury.

Ether (3)



Illustration 4

g00931562

This safety message is located under the hood for the engine compartment.



Explosion hazard! Do not use ether! This machine is equipped with an air inlet heater. Using ether can create explosions or fires that can cause personal injury or death. Read and follow the starting procedure in the Operation and Maintenance Manual.

Batteries (4)

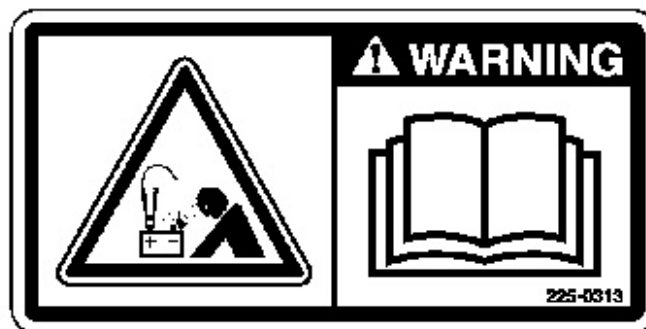

This safety message is located on the inside of the door for the battery compartment.



Explosion Hazard! Improper jumper cable connections can cause an explosion resulting in serious injury or death. Batteries may be located in separate compartments. When using jump start cables, always connect the positive (+) cable from the source to the positive (+) terminal of the battery that is connected to the starter solenoid. Connect the negative (-) cable from the source to the negative (-) terminal of the starter. If the machine is not equipped with a starter negative terminal, connect the negative (-) cable to the engine block. Follow the procedure in the Operation and Maintenance Manual.

High Pressure Accumulator (5)

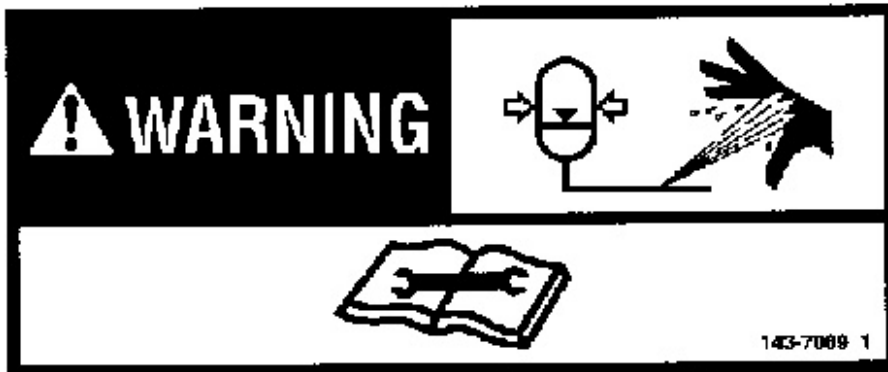

This safety message is located on the accumulator for the loader. This accumulator is located behind the battery compartment.



Hydraulic accumulator contains gas and oil under high pressure. Improper removal or repair procedures could cause severe injury. To

remove or repair, instructions in the service manual must be followed. Special equipment is required for testing and charging.

ROPS (6)

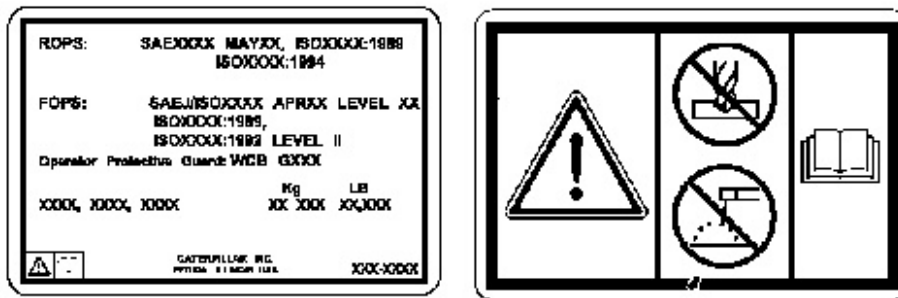

Illustration 7

g01033008

This safety message is located on the back of the cab.

WARNING

Structural damage, an overturn, modification, alteration, or improper repair can impair this structure's protection capability thereby voiding this certification. Do not weld on or drill holes in the structure. Consult a Caterpillar dealer to determine this structure's limitations without voiding its certification.

Crush Hazard (7)

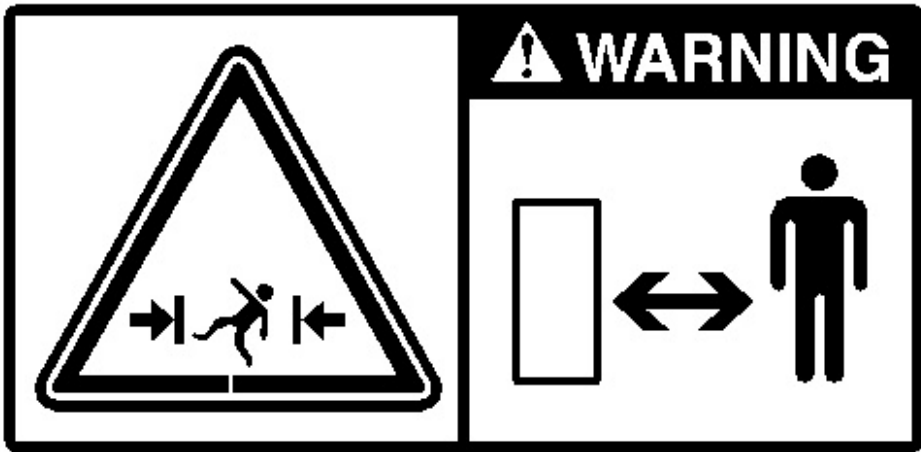

Illustration 8

g00930663

This safety message is located on the boom above the boom foot pin and sideways from the bottom wrapper plate.



Crushing Hazard! Stay back a safe distance. There is no clearance for a person in this area when the machine turns. Failure to follow these instructions could cause serious injury or death.

Keep Clear (8)



This safety message is located on the back of the cab.



Crush hazard; This is not an entrance or exit. Stay clear of this area when the machine is operating. Start and operate the backhoe from the operator seat only. Failure to follow these warnings could result in injury or death.

Brace The Lift Cylinder (9)



This safety message (if equipped) is located on the loader lift arm by the brace for the loader lift arm.



When performing any work underneath a raised loader lift arm, the loader lift arm brace must be in place. Install the loader lift arm brace as follows.

- 1. Empty loader bucket. Remove pin that secures loader lift arm brace to left loader arm. Raise loader arms to maximum height with the bucket in the dump position.**

2. Position service brace over left lift cylinder with flat end against cylinder end.
3. Push pin through holes of loader lift arm brace and install cotter pin.
4. Slowly lower loader arms until brace contacts the top of the lift cylinder and bosses on loader arm.
5. To remove loader lift arm brace, reverse procedure.

Failure to follow this procedure can result in death or serious injury if the loader arms are accidentally lowered.

Pressurized System (10)



Illustration 11

g00930639

This safety message is located in two locations by the cooling system filler cap.



Pressurized system: Hot coolant can cause serious burn. To open cap, stop engine, wait until radiator is cool. Then loosen cap slowly to relieve the pressure.

Improper Attachment of Work Tools (11)

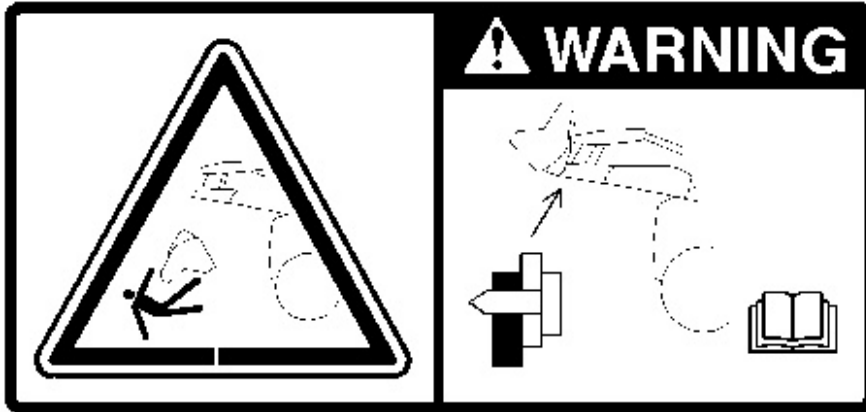

Illustration 12

g01032986

This safety message is located above the right side console.



Improper attachment of implements could result in injury or death.

Do not operate this machine until you have positive indication that the coupler pins are fully engaged. Follow recommended procedure in Operation and Maintenance Manual.

High Cylinder Pressure (12)



Illustration 13

g00997730

This safety message is located on the right side of the boom near the connection with the stick.



High Pressure Cylinder. Failure to read and follow these instructions can cause rapidly discharging gas and/or hydraulic fluid which can result in death, personal injury and property damage.

Previous Screen

Product: BACKHOE LOADER

Model: 436C BACKHOE LOADER 1PR

Configuration: 436C Backhoe Loader Center Pivot, Parallel Lift 1PR01599-01815 (MACHINE) POWERED BY 3054 Engine

Operation and Maintenance Manual
416C, 426C, 428C, 436C and 438C Backhoe Loaders

Media Number -SEBU6873-05

Publication Date -01/07/2008

Date Updated -14/07/2008

i03150004

Additional Messages

SMCS - 7000; 7405

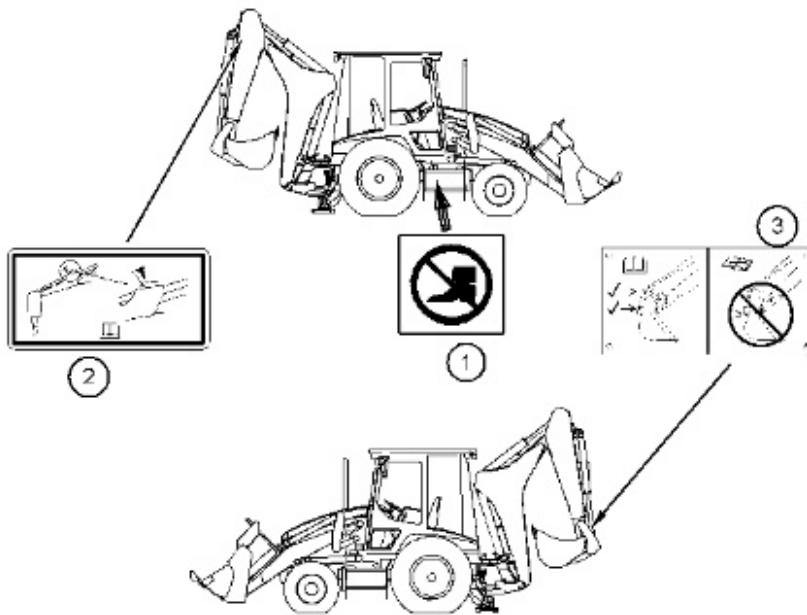

Illustration 1

g01190217

No Step (1)



Illustration 2

g00936182

This message is located inside the battery box.



Do not step here. Stepping here could cause damage to the work tool and personal injury.

Pin the Extendable Stick (2)

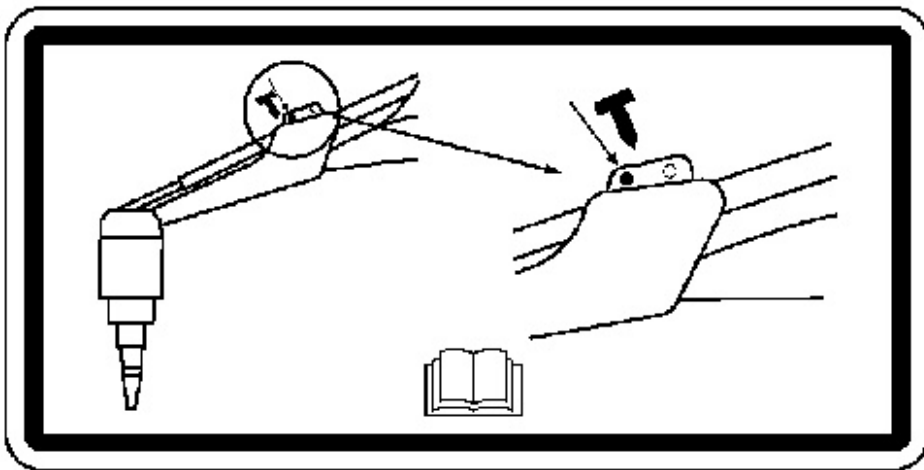

This message is located on the stick.



The E-Stick must be pinned before using attachments, to prevent movement which could cause personal injury.

Improper Location of the Backhoe Bucket (3)

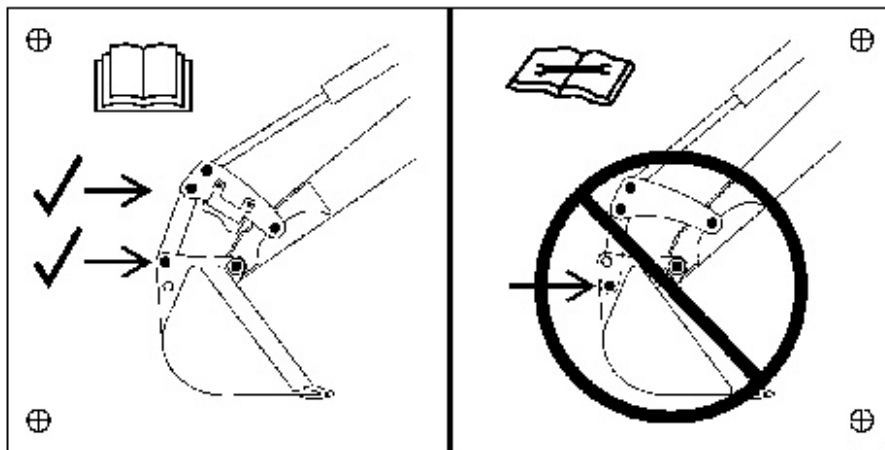

This message is located by the linkage for the backhoe bucket.



Improper bucket pin connection can cause machine damage. Make sure the bucket pins are connected properly.

[Previous Screen](#)

Product: BACKHOE LOADER

Model: 436C BACKHOE LOADER 1PR

Configuration: 436C Backhoe Loader Center Pivot, Parallel Lift 1PR01599-01815 (MACHINE) POWERED BY 3054 Engine

Operation and Maintenance Manual 416C, 426C, 428C, 436C and 438C Backhoe Loaders

Media Number -SEBU6873-05

Publication Date -01/07/2008

Date Updated -14/07/2008

i00609983

General Hazard Information

SMCS - 7000

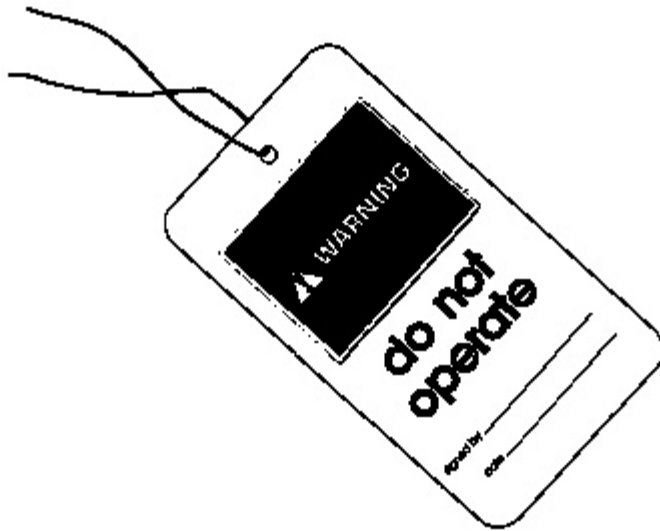

Illustration 1

g00037327

Before you service the machine or before you repair the machine, attach a "Do Not Operate" warning tag or a similar warning tag to the start switch or to the controls. These warning tags Special Instruction, SEHS7332 are available from your Caterpillar dealer.

Know the width of your equipment in order to maintain proper clearance near fences, boundary obstacles, etc.

Wear a hard hat, protective glasses and other protective equipment in order to accommodate job conditions.

Do not wear loose clothing or jewelry that can catch on controls or on other parts of the machine.

Ensure that all protective guards and all covers are secured in place on the machine.

Keep the machine free from foreign material. Check the deck, the walkways and the steps. Remove debris, oil, tools and other items.

Secure all loose items that are not a part of the machine. Secure lunch boxes, tools and other items.

Know the appropriate work site hand signals. Also, know the personnel that are authorized to give the hand signals. Accept signals from one person only.

Do not smoke when you service an air conditioner. Also, do not smoke if refrigerant gas may be present. Inhaling the fumes that are emitted from a flame that contacts air conditioner refrigerant can cause bodily harm or death. Inhaling gas from air conditioner refrigerant through a lighted cigarette can cause bodily harm or death.

Never put maintenance fluids into glass containers. Drain all liquids into a suitable container.

When you discard liquids, obey all local regulations.

Use all cleaning solutions with care.

Report all necessary repairs.

Do not allow unauthorized personnel on the machine.

Unless you are instructed otherwise, perform the maintenance with the following conditions:

- The machine is parked on level ground.
- The attachment controls are in HOLD position.
- The transmission control is in NEUTRAL position and the neutral lock is in the ON position.
- The parking brake is engaged.
- Lower the loader bucket until the loader bucket exerts a slight downward pressure onto the ground.
- The engine is stopped.
- The engine start switch in the OFF position and the key is removed.

Pressure Air

Pressure air can cause personal injury. When pressure air is used for cleaning, wear a protective face shield, protective clothing and protective shoes.

The maximum air pressure must be below 205 kPa (30 psi) for cleaning purposes.

Trapped Pressure

Pressure can be trapped in a hydraulic system. Trapped pressure can cause sudden machine movement or attachment movement. Use caution if you disconnect hydraulic lines or fittings. High pressure oil that is released can cause a hose to whip. High pressure oil that is released can cause oil to spray. Fluid penetration can cause serious injury and possible death.

Fluid Penetration

When you check for a leak, use a board or cardboard. Leaking fluid that is under pressure can penetrate body tissue. Fluid penetration can cause serious injury and possible death. A pin hole leak can cause severe injury. If fluid is injected into your skin, you must obtain treatment immediately. Seek treatment from a doctor that is familiar with this type of injury.

Asbestos Information

Caterpillar equipment and replacement parts that are shipped from Caterpillar are asbestos free. Caterpillar recommends the use of only genuine Caterpillar replacement parts. If any replacement parts that contain asbestos are used, the following guidelines should be used in handling these parts and asbestos debris.

Use caution. Avoid inhaling dust that might be generated when you handle components that contain asbestos fibers. If this dust is inhaled, it can be hazardous to your health. The components that may contain asbestos fibers are brake pads, brake bands, lining material, clutch plates, and some gaskets. The asbestos that is used in these components is usually bound in a resin or sealed in some way. Normal handling is not hazardous, unless airborne dust that contains asbestos is generated.

If dust which can contain asbestos is present, there are several guidelines that should be followed:

- Never use compressed air for cleaning.
 - Avoid sweeping materials that contain asbestos.
 - Also avoid grinding materials that contain asbestos.
 - Use a wet method in order to clean up asbestos materials.
 - You may also use a vacuum that is equipped with a highly efficient filter that cleans particulate air.
 - Use exhaust ventilation on permanent machining jobs.
 - Wear an approved respirator if there is no other way to control the dust.
 - Comply with applicable rules and regulations for the work place. In the USA, use Occupational Safety and Health Administration requirements. These OSHA requirements can be found in "29 CFR 1910.1001".
 - Obey environmental rules for the disposal of asbestos and obey environmental regulations for the disposal of asbestos.
 - Stay away from areas that might have asbestos particles in the air.
-

[Previous Screen](#)

Product: BACKHOE LOADER

Model: 436C BACKHOE LOADER 1PR

Configuration: 436C Backhoe Loader Center Pivot, Parallel Lift 1PR01599-01815 (MACHINE) POWERED BY 3054 Engine

Operation and Maintenance Manual 416C, 426C, 428C, 436C and 438C Backhoe Loaders

Media Number -SEBU6873-05

Publication Date -01/07/2008

Date Updated -14/07/2008

i00081360

Crushing Prevention and Cutting Prevention

SMCS - 7000

Support the equipment properly when you work beneath the equipment. Do not depend on the hydraulic cylinders to hold up the equipment. An attachment can fall if a control is moved, or if a hydraulic line breaks.

Unless you are instructed otherwise, never attempt adjustments while the machine is moving. Also, never attempt adjustments while the engine is running.

Whenever there are attachment linkages, the clearance in the linkage area will increase or the clearance in the linkage area will decrease with movement of the attachment.

Stay clear of all rotating parts and all moving parts.

Keep objects away from moving fan blades. The fan blade will throw objects or the fan blade will cut objects.

Do not use a kinked wire rope cable or a frayed wire rope cable. Wear gloves when you handle wire rope cable.

When you strike a retainer pin with force, the retainer pin can fly out. The loose retainer pin can injure personnel. Make sure that the area is clear of people when you strike a retainer pin.

In order to avoid injury to your eyes, wear protective glasses when you strike a retainer pin.

Chips or other debris can fly off objects when you strike the objects. Ensure that an injury will not occur from flying debris before you hit any object.

Rollover Protective Structure (ROPS) or Falling Objects Protective Structure (FOPS)

These guards are positioned above the operator's compartment and these guards are secured to the machine.

To avoid the possible weakening of the ROPS or of the FOPS, consult a Caterpillar dealer before you alter the guards. Do not alter the structure by welding, cutting, adding weight, or drilling holes into the structure.

Any alteration that is not specifically authorized by Caterpillar invalidates the Caterpillar certification for the ROPS and for the FOPS. The protection that is offered by the ROPS will be impaired if the ROPS has structural damage. Damage to the structure can be caused by an overturn, falling objects, etc.

Do not weld brackets to the ROPS and do not drill holes in the ROPS in order to mount fire extinguishers, first aid kits, and lights to the ROPS structure. Consult your Caterpillar dealer for mounting guidelines.

[Previous Screen](#)

Product: BACKHOE LOADER

Model: 436C BACKHOE LOADER 1PR

Configuration: 436C Backhoe Loader Center Pivot, Parallel Lift 1PR01599-01815 (MACHINE) POWERED BY 3054 Engine

Operation and Maintenance Manual 416C, 426C, 428C, 436C and 438C Backhoe Loaders

Media Number -SEBU6873-05

Publication Date -01/07/2008

Date Updated -14/07/2008

i04760300

Burn Prevention

SMCS - 7000

Do not touch any part of an operating engine. Allow the engine to cool before any maintenance is performed on the engine. Relieve all pressure in the air system, in the oil system, in the lubrication system, in the fuel system, or in the cooling system before any lines, fittings, or related items are disconnected.

Coolant

When the engine is at operating temperature, the engine coolant is hot. The coolant is also under pressure. The radiator and all lines to the heaters or to the engine contain hot coolant.

Any contact with hot coolant or with steam can cause severe burns. Allow cooling system components to cool before the cooling system is drained.

Check the coolant level only after the engine has been stopped.

Ensure that the filler cap is cool before removing the filler cap. The filler cap must be cool enough to touch with a bare hand. Remove the filler cap slowly in order to relieve pressure.

Cooling system conditioner contains alkali. Alkali can cause personal injury. Do not allow alkali to contact the skin, the eyes, or the mouth.

Oils

Hot oil and hot components can cause personal injury. Do not allow hot oil to contact the skin. Also, do not allow hot components to contact the skin.

Remove the hydraulic tank filler cap only after the engine has been stopped. The filler cap must be cool enough to touch with a bare hand. Follow the standard procedure in this manual in order to remove the hydraulic tank filler cap.

Batteries

The liquid in a battery is an electrolyte. Electrolyte is an acid that can cause personal injury. Do not allow electrolyte to contact the skin or the eyes.

Do not smoke while checking the battery electrolyte levels. Batteries give off flammable fumes which can explode.

Always wear protective glasses when you work with batteries. Wash hands after touching batteries. The use of gloves is recommended.

[Previous Screen](#)

Product: BACKHOE LOADER

Model: 436C BACKHOE LOADER 1PR

Configuration: 436C Backhoe Loader Center Pivot, Parallel Lift 1PR01599-01815 (MACHINE) POWERED BY 3054 Engine

Operation and Maintenance Manual 416C, 426C, 428C, 436C and 438C Backhoe Loaders

Media Number -SEBU6873-05

Publication Date -01/07/2008

Date Updated -14/07/2008

i00837742

Fire Prevention and Explosion Prevention

SMCS - 7000



Dust created during repair of fenders and/or hood on this machine can be explosive. Refer to Special Instruction, REHS0034, "Guideline for Repair of Non-metallic Fenders and Hoods" before attempting any repair.

All fuels, most lubricants, and some coolant mixtures are flammable.

Fuel that is leaking, fuel that is spilled onto hot surfaces, and fuel that is spilled onto electrical components can cause a fire.

Do not smoke while you refuel or while you are in a refueling area.

Do not smoke in battery charging areas or in areas that are used to store flammable material.

Batteries can be installed in separate compartments. When you use jump start cables, always connect the positive "(+)" cable to the positive "(+)" terminal of the battery that is connected to the starter solenoid. Connect the negative "(-)" cable from the external source to the negative "(-)" terminal of the starter.

Note: If the starter is not equipped with a negative "(-)" terminal, connect the cable to the engine block.

See the Operation Section of this manual for specific starting instructions.

Clean all electrical connections and tighten all electrical connections. Check the electrical wires daily for loose wires or for frayed wires. Tighten all loose wires before you operate the machine. Repair all frayed wires before you operate the machine.

Store all fuels and lubricants in properly marked containers and away from all unauthorized persons.

Store all oily rags or other flammable material in a protective container.

Do not weld pipes that contain flammable fluids or tubes that contain flammable fluids. Do not flame cut pipes that contain flammable fluids or tubes that contain flammable fluids. Clean the pipes or tubes thoroughly with nonflammable solvent before you weld the pipes or tubes or you flame cut the pipes or tubes.

Remove all flammable materials (fuel, oil, debris, etc) before the flammable materials accumulate on the machine.

Do not expose the machine to flames or to brush that is burning.

Shields protect hot exhaust components from oil spray or fuel spray. Make sure that the shields are installed correctly in case a line, a tube, or a seal fails.

Ether

Do not spray ether into an engine when you use thermal starting aid to start the engine. Ether is not used on this machine.

Ether is poisonous and flammable. Inhaling ether vapors can cause personal injury. Do not allow ether to contact your skin repeatedly. Use ether only in well ventilated areas. Do not store ether cylinders in living areas or in the operator's compartment.

Do not store ether cylinders in direct sunlight or at temperatures above 40°C (102°F). Discard ether cylinders in an approved place. Do not puncture ether cylinders. Do not burn ether cylinders. Keep ether cylinders out of the reach of unauthorized personnel.

Lines, Tubes and Hoses

Do not bend high pressure lines. Do not strike high pressure lines. Do not install bent lines, bent tubes, or bent hoses. Do not install damaged lines, damaged tubes, or damaged hoses.

Repair loose lines, loose tubes, and loose hoses. Repair damaged lines, damaged tubes, and damaged hoses. Leaks can cause fires. See your Caterpillar dealer for repair or for replacement parts.

Check lines, tubes and hoses carefully. Do not use your bare hand to check for leaks. Use a board or cardboard to check for leaks. See Operation and Maintenance Manual, "Fluid Penetration" for more details. Tighten all connections to the recommended torque.

Replace the parts if any of the following conditions are present:

- The end fittings are damaged or leaking.
- The outer covering is chafed or cut.
- The wire shield is exposed.
- The outer covering is ballooning locally.

- The flexible part of the hose is kinked or crushed.
- The armoring is embedded in the outer cover.
- The end fittings are displaced.

Make sure that all clamps, guards, and heat shields are installed correctly. This will help to prevent vibration, rubbing other parts and excessive heat.

Thank you so much for reading.
Please click the “Buy Now!”
button below to download the
complete manual.



After you pay.

You can download the most
perfect and complete manual in
the world immediately.

Our support email:

ebooklibonline@outlook.com