

Product: EXCAVATOR

Model: M318 EXCAVATOR 6ES

Configuration: M318 Excavator 6ES00001-UP (MACHINE) POWERED BY 3116 Engine

Operation and Maintenance Manual 307B, 311–330 B-D Series, 345–5090 B and C Series and M312-M322 A-D Series Excavators

Media Number -SEBU8315-04

Publication Date -01/11/2011

Date Updated -11/11/2011

s00037320

Foreword

SMCS - 7606

Literature Information

This manual should be stored in the operator's compartment in the literature holder or seat back literature storage area.

This manual contains safety information, operation instructions, transportation information, lubrication information and maintenance information.

Some photographs or illustrations in this publication show details or attachments that can be different from your machine. Guards and covers might have been removed for illustrative purposes.

Continuing improvement and advancement of product design might have caused changes to your machine which are not included in this publication. Read, study and keep this manual with the machine.

Whenever a question arises regarding your machine, or this publication, please consult your Cat dealer for the latest available information.

Safety

The safety section lists basic safety precautions. In addition, this section identifies the text and locations of warning signs and labels used on the machine.

Read and understand the basic precautions listed in the safety section before operating or performing lubrication, maintenance and repair on this machine.

Operation

The operation section is a reference for the new operator and a refresher for the experienced operator. This section includes a discussion of gauges, switches, machine controls, attachment controls, transportation and towing information.

Photographs and illustrations guide the operator through correct procedures of checking, starting, operating and stopping the machine.

Operating techniques outlined in this publication are basic. Skill and techniques develop as the operator gains knowledge of the machine and its capabilities.

Maintenance

The maintenance section is a guide to equipment care. The Maintenance Interval Schedule (MIS) lists the items to be maintained at a specific service interval. Items without specific intervals are listed under the "When Required" service interval. The Maintenance Interval Schedule lists the page number for the step-by-step instructions required to accomplish the scheduled maintenance. Use the Maintenance Interval Schedule as an index or "one safe source" for all maintenance procedures.

Maintenance Intervals

Use the service hour meter to determine servicing intervals. Calendar intervals shown (daily, weekly, monthly, etc.) can be used instead of service hour meter intervals if they provide more convenient servicing schedules and approximate the indicated service hour meter reading. Recommended service should always be performed at the interval that occurs first.

Under extremely severe, dusty or wet operating conditions, more frequent lubrication than is specified in the maintenance intervals chart might be necessary.

Perform service on items at multiples of the original requirement. For example, at every 500 service hours or 3 months, also service those items listed under every 250 service hours or monthly and every 10 service hours or daily.

California Proposition 65 Warning

Diesel engine exhaust and some of its constituents are known to the State of California to cause cancer, birth defects, and other reproductive harm.

Battery posts, terminals and related accessories contain lead and lead compounds. **Wash hands after handling.**

Certified Engine Maintenance

Proper maintenance and repair is essential to keep the engine and machine systems operating correctly. As the heavy duty off-road diesel engine owner, you are responsible for the performance of the required maintenance listed in the Owner Manual, Operation and Maintenance Manual, and Service Manual.

It is prohibited for any person engaged in the business of repairing, servicing, selling, leasing, or trading engines or machines to remove, alter, or render inoperative any emission related device or element of design installed on or in an engine or machine that is in compliance with the

regulations (40 CFR Part 89). Certain elements of the machine and engine such as the exhaust system, fuel system, electrical system, intake air system and cooling system may be emission related and should not be altered unless approved by Caterpillar.

Machine Capacity

Additional attachments or modifications may exceed machine design capacity which can adversely affect performance characteristics. Included would be stability and system certifications such as brakes, steering, and rollover protective structures (ROPS). Contact your Cat dealer for further information.

Cat Product Identification Number

Effective First Quarter 2001 the Cat Product Identification Number (PIN) has changed from 8 to 17 characters. In an effort to provide uniform equipment identification, Caterpillar and other construction equipment manufacturers are moving to comply with the latest version of the product identification numbering standard. Non-road machine PINs are defined by ISO 10261. The new PIN format will apply to all Cat machines and generator sets. The PIN plates and frame marking will display the 17 character PIN. The new format will look like the following:

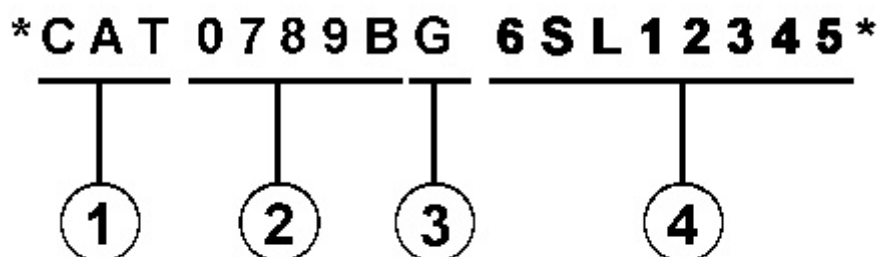

Illustration 1

g00751314

Where:

1. Caterpillar's World Manufacturing Code (characters 1-3)
2. Machine Descriptor (characters 4-8)
3. Check Character (character 9)
4. Machine Indicator Section (MIS) or Product Sequence Number (characters 10-17). These were previously referred to as the Serial Number.

Machines and generator sets produced before First Quarter 2001 will maintain their 8 character PIN format.

Components such as engines, transmissions, axles, etc. and work tools will continue to use an 8 character Serial Number (S/N).

Product: EXCAVATOR

Model: M318 EXCAVATOR 6ES

Configuration: M318 Excavator 6ES00001-UP (MACHINE) POWERED BY 3116 Engine

Operation and Maintenance Manual 307B, 311–330 B-D Series, 345–5090 B and C Series and M312-M322 A-D Series Excavators

Media Number -SEBU8315-04

Publication Date -01/11/2011

Date Updated -11/11/2011

i04159629

Work Tools

SMCS - 6700

Only use work tools that are recommended by Caterpillar for use on Cat machines.

Use of work tools, including buckets, which are outside of Caterpillar's recommendations or specifications for weight, dimensions, flows, pressures, and so on. may result in less-than-optimal vehicle performance, including but not limited to reductions in production, stability, reliability, and component durability. Caterpillar recommends appropriate work tools for our machines to maximize the value our customers receive from our products. Caterpillar understands that special circumstances may lead a customer to use tools outside of our specifications. In these cases, customers must be aware that such choices can reduce vehicle performance and will affect their ability to claim warranty in the event of what a customer may perceive as a premature failure.

Work tools and work tool control systems, that are compatible with your Cat machine, are required for safe machine operation and/or reliable machine operation. If you are in doubt about the compatibility of a particular work tool with your machine, consult your Cat dealer.

Make sure that all necessary guarding is in place on the host machine and on the work tool.

Keep all windows and doors closed on the host machine. A polycarbonate shield must be used when the host machine is not equipped with windows and when a work tool could throw debris.

Do not exceed the maximum operating weight that is listed on the ROPS certification.

If your machine is equipped with an extendable stick, install the transport pin when you are using the following work tools: hydraulic hammers, augers and compactors

Always wear protective glasses. Always wear the protective equipment that is recommended in the operation manual for the work tool. Wear any other protective equipment that is required for the operating environment.

To prevent personnel from being struck by flying objects, ensure that all personnel are out of the work area.

While you are performing any maintenance, any testing, or any adjustments to the work tool stay clear of the following areas: cutting edges, pinching surfaces and crushing surfaces.

Never use the work tool for a work platform.

Product: EXCAVATOR

Model: M318 EXCAVATOR 6ES

Configuration: M318 Excavator 6ES00001-UP (MACHINE) POWERED BY 3116 Engine

Operation and Maintenance Manual 307B, 311–330 B-D Series, 345–5090 B and C Series and M312-M322 A-D Series Excavators

Media Number -SEBU8315-04

Publication Date -01/11/2011

Date Updated -11/11/2011

i07262981

Lifting Objects

SMCS - 7000

There may be local regulations and/or government regulations that govern the use of machines which lift heavy objects. Obey all local and government regulations.

If this machine is used to lift objects within an area that is controlled by the European Directive "2006/42/EC", the machine must be equipped with a boom lowering control valve, a stick lowering control valve, and an overload warning device.

Product: EXCAVATOR

Model: M318 EXCAVATOR 6ES

Configuration: M318 Excavator 6ES00001-UP (MACHINE) POWERED BY 3116 Engine

Operation and Maintenance Manual 307B, 311–330 B-D Series, 345–5090 B and C Series and M312-M322 A-D Series Excavators

Media Number -SEBU8315-04

Publication Date -01/11/2011

Date Updated -11/11/2011

i06139647

Bucket - Remove and Install

SMCS - 6001-011; 6001; 6101; 6102; 6523

Captured Flag



WARNING

Failure to follow the instruction below for the installation of a work tool may result in personal injury or death. Special care must be taken if more than one person is installing the work tool.

- **Confirm the verbal communication and the hand signals that will be used during the installation.**
- **Be alert for sudden movement of the front linkage and the work tool.**
- **Do not insert fingers into the bores of the support pins when the support pins and the bores are being aligned.**

NOTICE

To facilitate removal of the bucket pins without causing damage to the pins, the bearings, and/or the O-ring seals put the bucket on the floor and the stick in a vertical position, as shown.

Removal Procedure

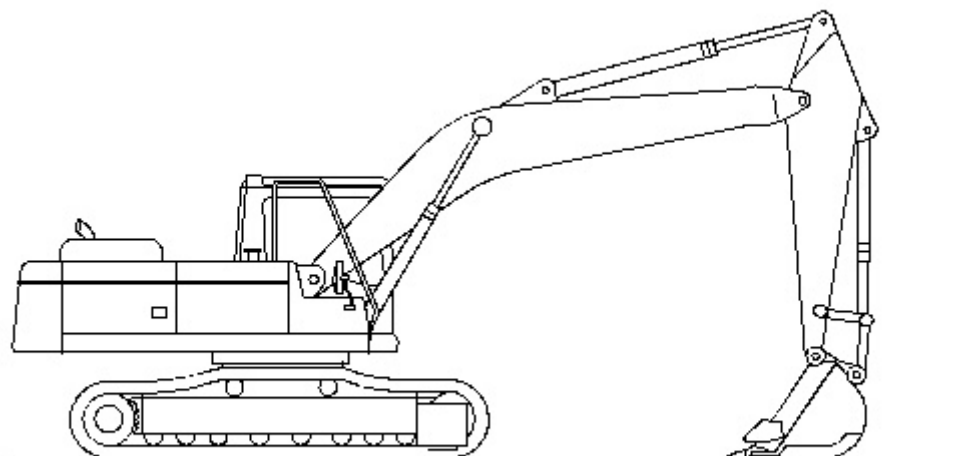

Illustration 1

g02154493

1. Start the engine. Park the machine on a hard, level surface. Position the bucket, the stick, and the bucket control linkage, as shown. Shut off the engine.

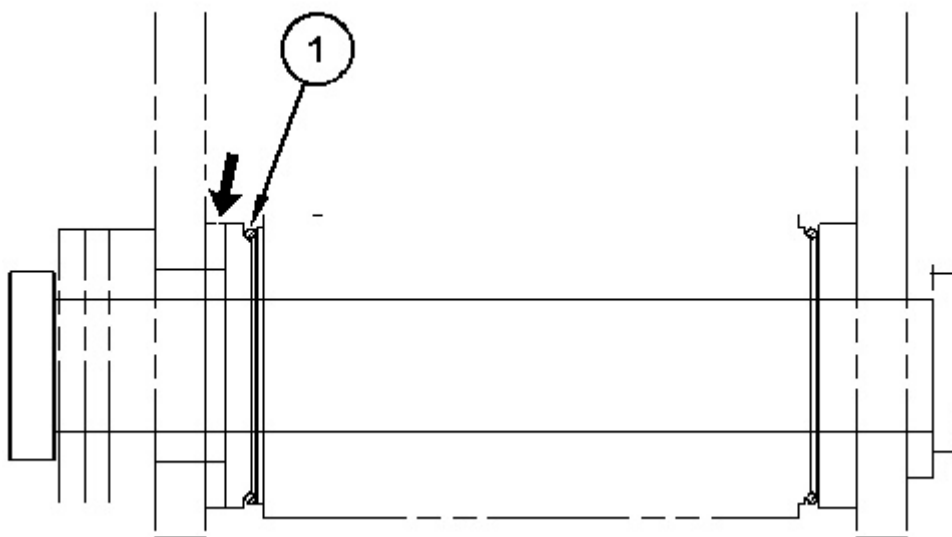

Illustration 2

g03822729

2. Slide O-ring seals (1) off the pin joints and onto the flanges of the bucket.



When the pin assembly is removed, the linkage assembly may swing out of the bucket. To prevent possible personal injury, do not stand in front of the linkage assembly when the pin assembly is being removed.

Note: Removing the support pin may be difficult due to excessive pressure on the support pin. Remove the pressure on the support pin by adjusting the front linkage.

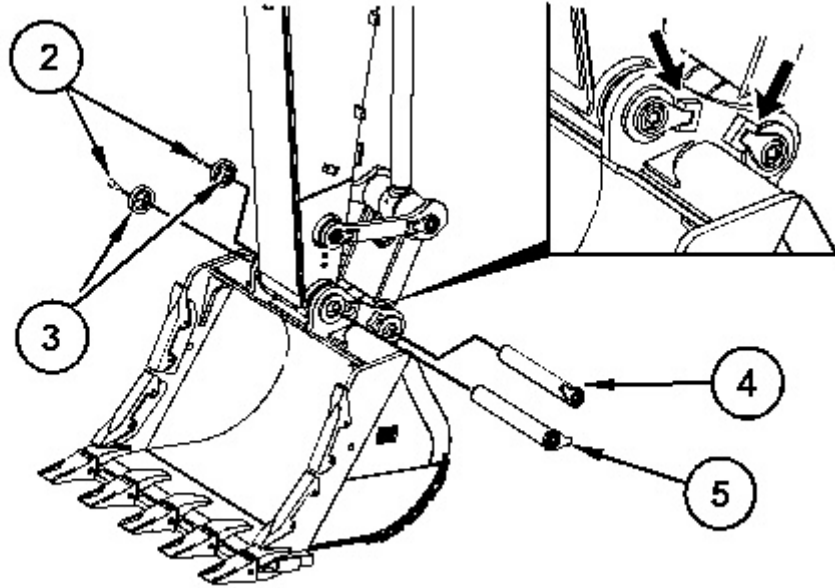

Illustration 3

g03822731

3. Remove bolts (2) and retaining plates (3). Then remove support pin (4) and support pin (5).
4. Start the engine and raise the stick out of the bucket.
5. Remove the O-ring seals (1) from the flanges on the bucket.

Note: After the support pins have been removed, make sure that the support pins do not become contaminated with sand or dirt. Make sure that the seals on the end of the stick and the seals on the end of the link do not become damaged.

Installation Procedure

1. Clean each pin and each pin bore. Lubricate each pin bore with molybdenum grease.
-

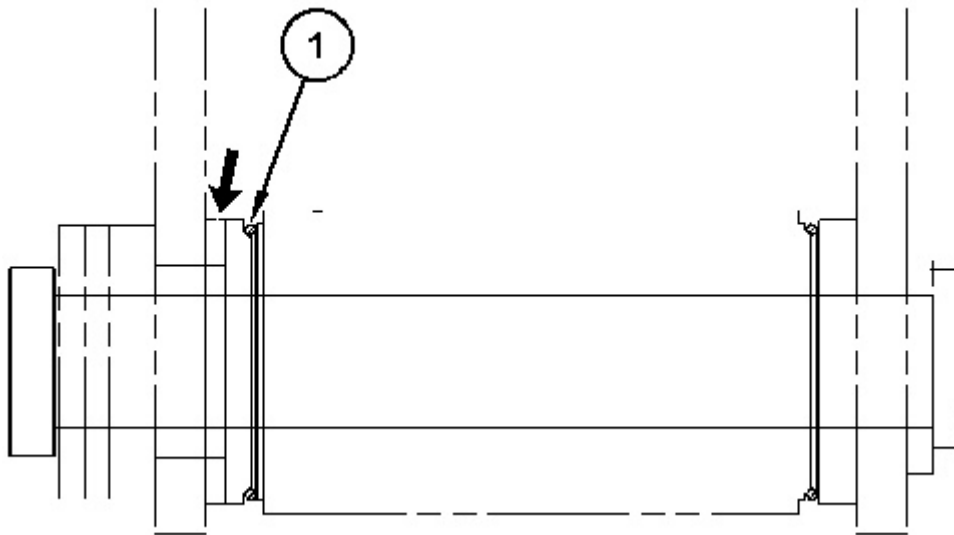

Illustration 4

g03822729

2. Position the O-ring seals (1) onto the flanges of the bucket.
3. Start the engine and lower the stick into the bucket until the pin bores are in alignment with each other. Stop the engine.

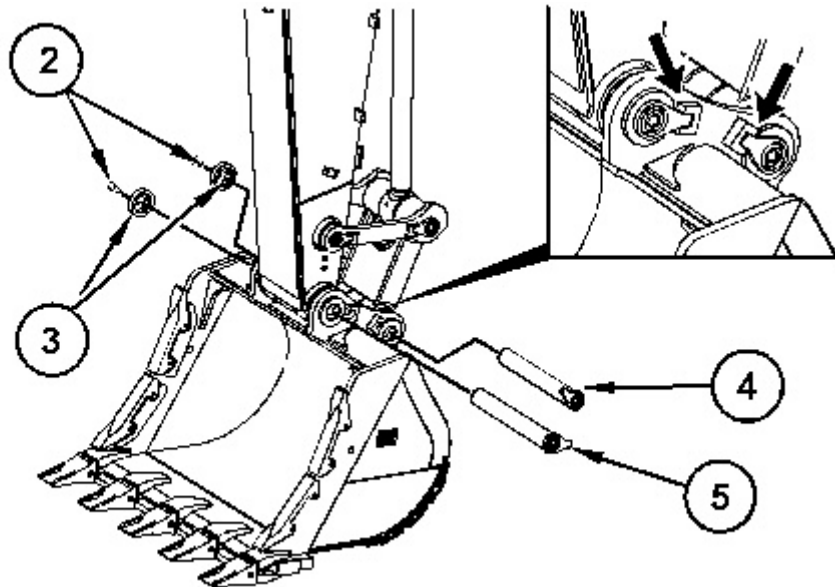

Illustration 5

g03822731

4. Insert support pin (5) into the pin bore. Make sure that the flange of the support pin rest inside the support on the side of the bucket.
5. Refer to Operation and Maintenance Manual, "Bucket Linkage - Inspect/Adjust" in order to adjust the bucket clearance.
6. Install retaining plate (3). Install bolts (2). Tighten bolts (2) evenly.

7. Slide O-ring seals (1) in position over the pin joints between the bucket and the stick.
8. Start the engine and position the bucket linkage into the bucket until the pin bores are in alignment with each other. Stop the engine.
9. Insert support pin (4) into the pin bore. Make sure that the flange of the support pin rest inside the support on the side of the bucket.
10. Install retaining plate (3). Install bolts (2). Tighten bolts (2) evenly.
11. Slide the O-ring seals (1) over the pin joints between the bucket and the link assembly.
12. Lubricate the bucket pins. Refer to Operation and Maintenance Manual, "Bucket Linkage - Lubricate" or Operation and Maintenance Manual, "Boom, Stick, and Bucket Linkage - Lubricate".

Bolted Flag



Failure to follow the instruction below for the installation of a work tool may result in personal injury or death. Special care must be taken if more than one person is installing the work tool.

- **Confirm the verbal communication and the hand signals that will be used during the installation.**
- **Be alert for sudden movement of the front linkage and the work tool.**
- **Do not insert fingers into the bores of the support pins when the support pins and the bores are being aligned.**

NOTICE

To facilitate removal of the bucket pins without causing damage to the pins, the bearings, and/or the O-ring seals put the bucket on the floor and the stick in a vertical position, as shown.

Removal Procedure

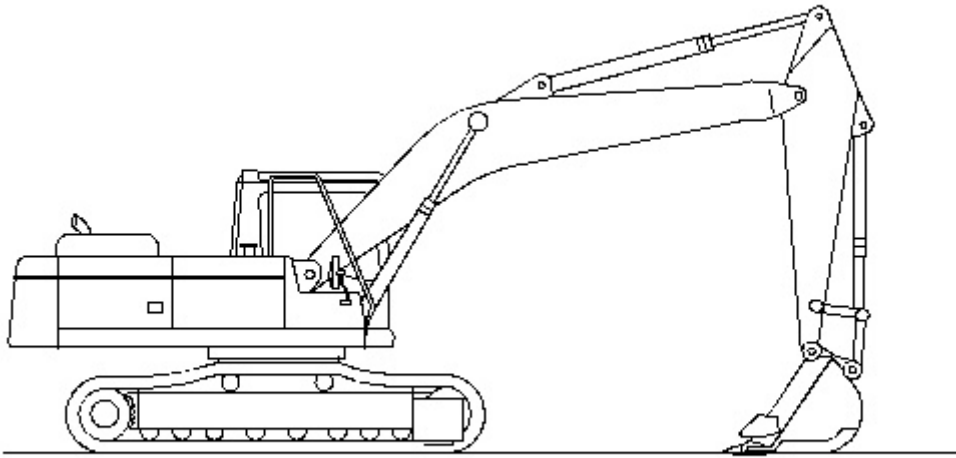

Illustration 6

g02154493

1. Start the engine. Park the machine on a hard, level surface. Position the bucket, the stick, and the bucket control linkage, as shown. Shut off the engine.

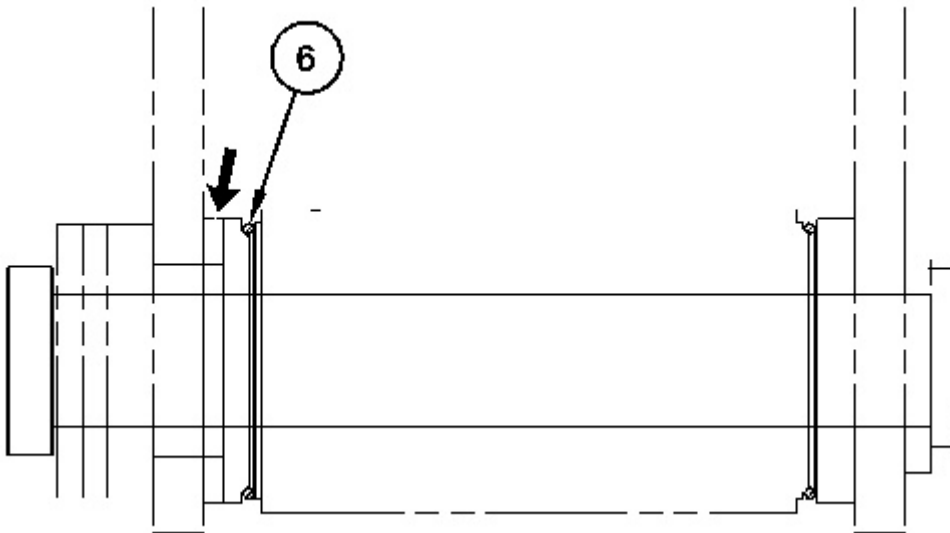

Illustration 7

g03822734

2. Slide O-ring seals (6) off the pin joints and onto the flanges of the bucket.

 **WARNING**

When the pin assembly is removed, the linkage assembly may swing out of the bucket. To prevent possible personal injury, do not stand in front of the linkage assembly when the pin assembly is being removed.

Note: Removing the support pin may be difficult due to excessive pressure on the support pin. Remove the pressure on the support pin by adjusting the front linkage.

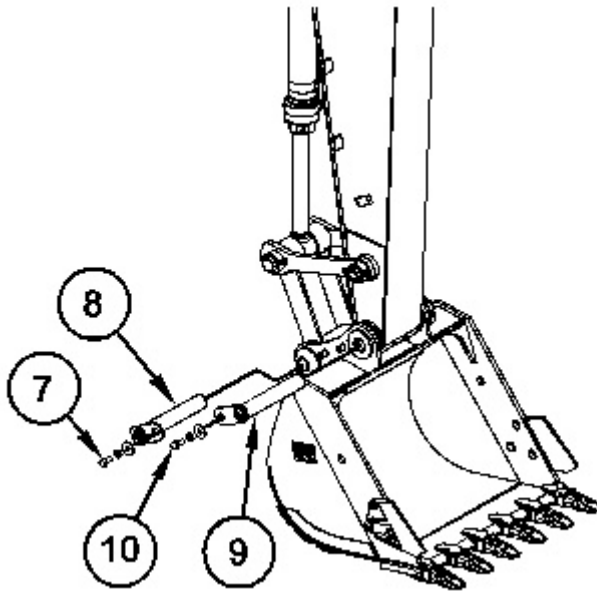

Illustration 8

g03822736

3. Remove bolt (7). Remove support pin (8).
4. Remove bolt (10). Remove support pin (9).
5. Start the engine and raise the stick out of the bucket.
6. Remove the O-ring seals (6) from the flanges on the bucket.

Note: After the support pins have been removed, make sure that the support pins do not become contaminated with sand or dirt. Make sure that the seals on the end of the stick and the seals on the end of the link do not become damaged.

Installation Procedure

1. Clean each pin and each pin bore. Lubricate each pin bore with molybdenum grease.
-

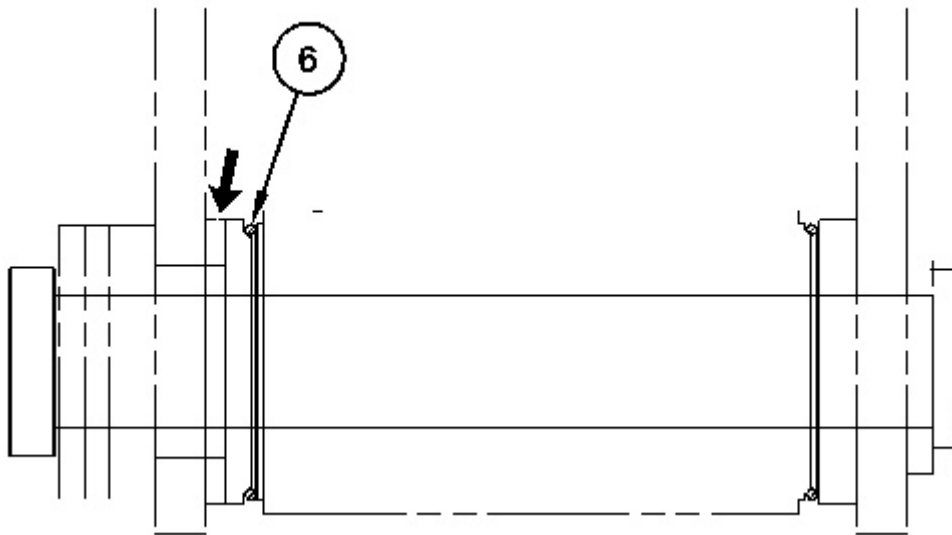

Illustration 9

g03822734

2. Position the O-ring seals (6) onto the flanges of the bucket.

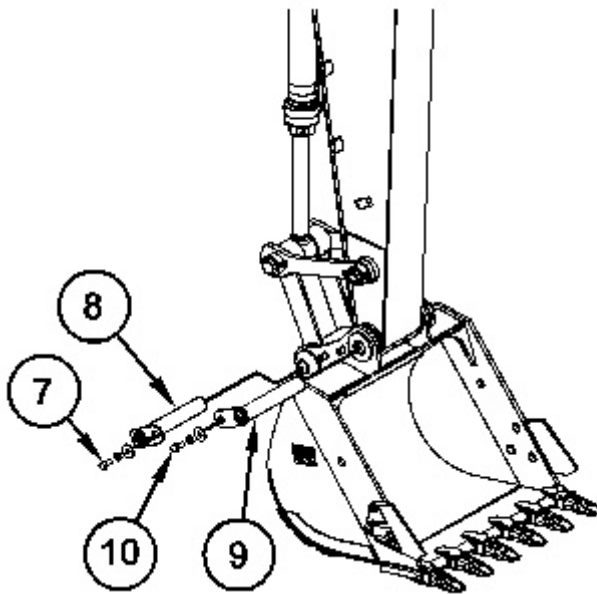

Illustration 10

g03822736

3. Start the engine and lower the stick into the bucket until the pin bores are in alignment with each other. Stop the engine.
4. Install support pin (9) into the pin bore.
5. Install bolt (10).
6. Refer to Operation and Maintenance Manual, "Bucket Linkage - Inspect/Adjust" in order to adjust the bucket clearance.
7. Slide O-ring seals (6) in position over the pin joints between the bucket and the stick.

8. Start the engine and position the bucket linkage into the bucket until the pin bores are in alignment with each other. Stop the engine.
9. Install support pin (8) into the pin bore.
10. Install Bolt (7).
11. Slide the O-ring seals (6) over the pin joints between the bucket and the link assembly.
12. Lubricate the bucket pins. Refer to Operation and Maintenance Manual, "Bucket Linkage - Lubricate" or Operation and Maintenance Manual, "Boom, Stick, and Bucket Linkage - Lubricate".

Crossbolt



Failure to follow the instruction below for the installation of a work tool may result in personal injury or death. Special care must be taken if more than one person is installing the work tool.

- **Confirm the verbal communication and the hand signals that will be used during the installation.**
- **Be alert for sudden movement of the front linkage and the work tool.**
- **Do not insert fingers into the bores of the support pins when the support pins and the bores are being aligned.**

NOTICE

To facilitate removal of the bucket pins without causing damage to the pins, the bearings, and/or the O-ring seals put the bucket on the floor and the stick in a vertical position, as shown.

Removal Procedure

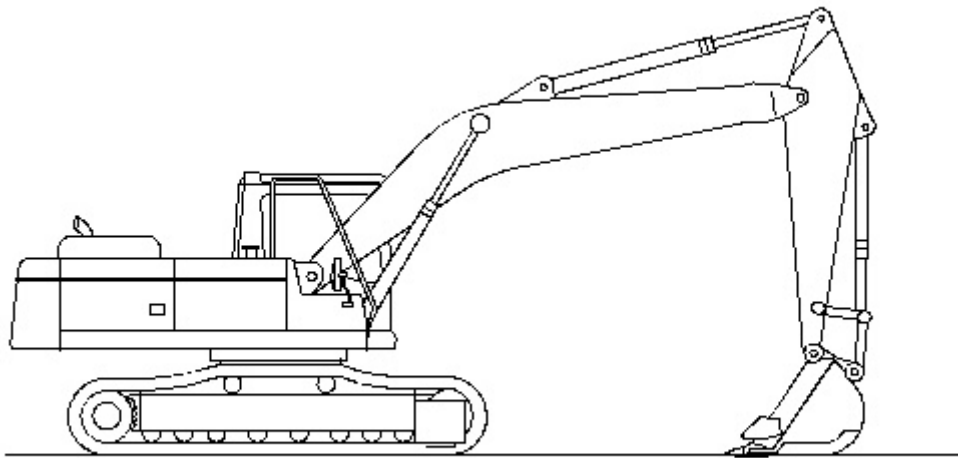

Illustration 11

g02154493

1. Start the engine. Park the machine on a hard, level surface. Position the bucket, the stick, and the bucket control linkage, as shown. Shut off the engine.

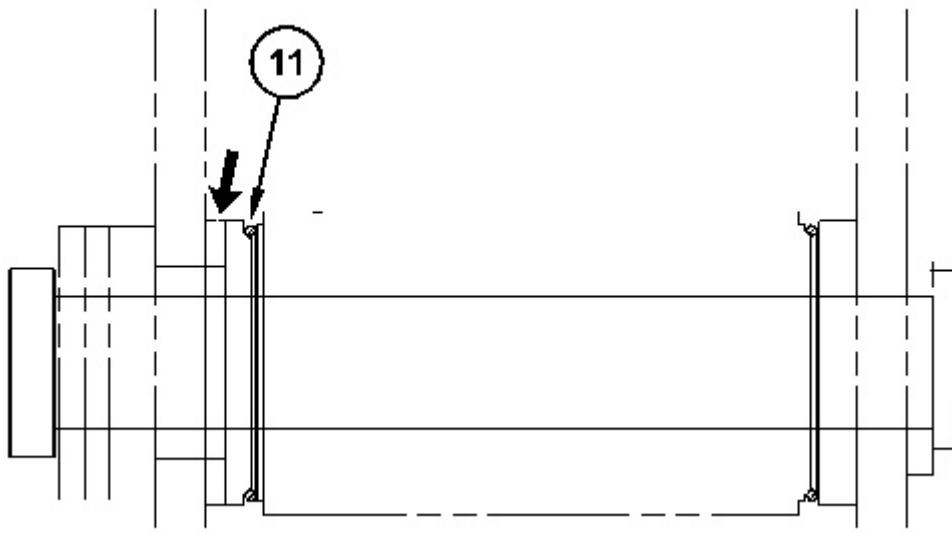

Illustration 12

g03822738

2. Slide O-ring seals (11) off the pin joints and onto the flanges of the bucket.

 **WARNING**

When the pin assembly is removed, the linkage assembly may swing out of the bucket. To prevent possible personal injury, do not stand in front of the linkage assembly when the pin assembly is being removed.

Note: Removing the support pin may be difficult due to excessive pressure on the support pin. Remove the pressure on the support pin by adjusting the front linkage.

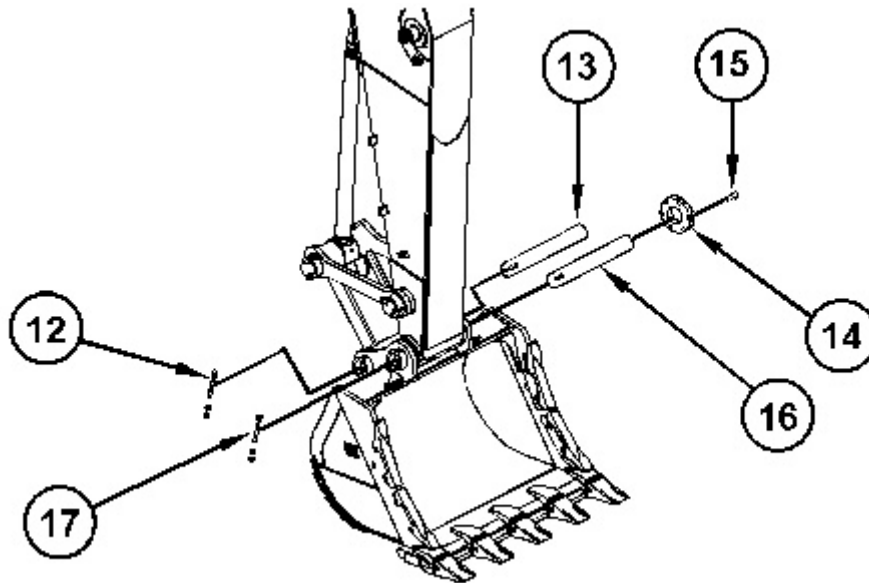

Illustration 13

g03822739

3. Remove nuts and retaining bolt (12) from support pin (13). Remove support pin (13).
4. Remove bolts (15) and adapter plate (14). Remove the shims.
5. Remove nuts and retaining bolt (17) from support pin (16). Remove support pin (16).
6. Start the engine and raise the stick out of the bucket.
7. Remove the O-ring seals (11) from the flanges on the bucket.

Note: After the support pins have been removed, make sure that the support pins do not become contaminated with sand or dirt. Make sure that the seals on the end of the stick and the seals on the end of the link do not become damaged.

Installation Procedure

1. Clean each pin and each pin bore. Lubricate each pin bore with molybdenum grease.
-

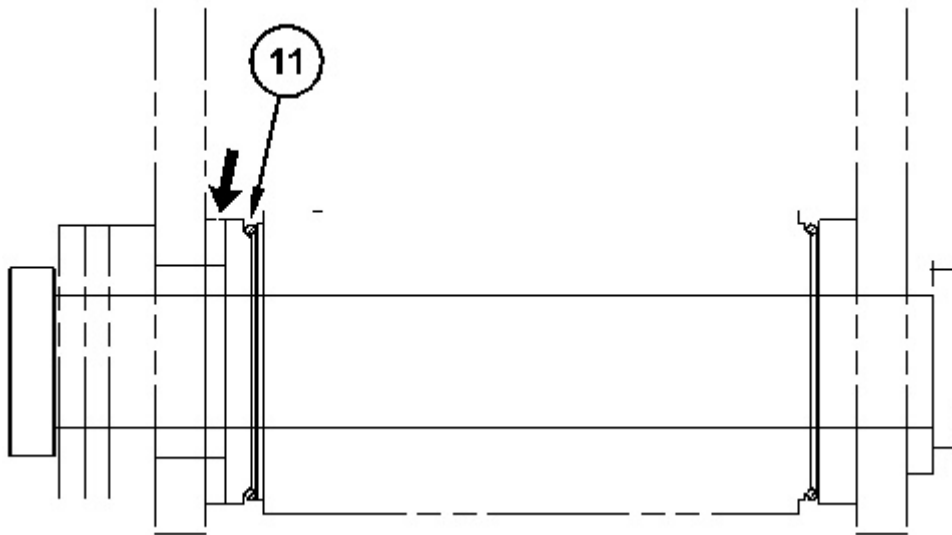

Illustration 14

g03822738

2. Position the O-ring seals (11) onto the flanges of the bucket.
3. Start the engine and lower the stick into the bucket until the pin bores are in alignment with each other. Stop the engine.

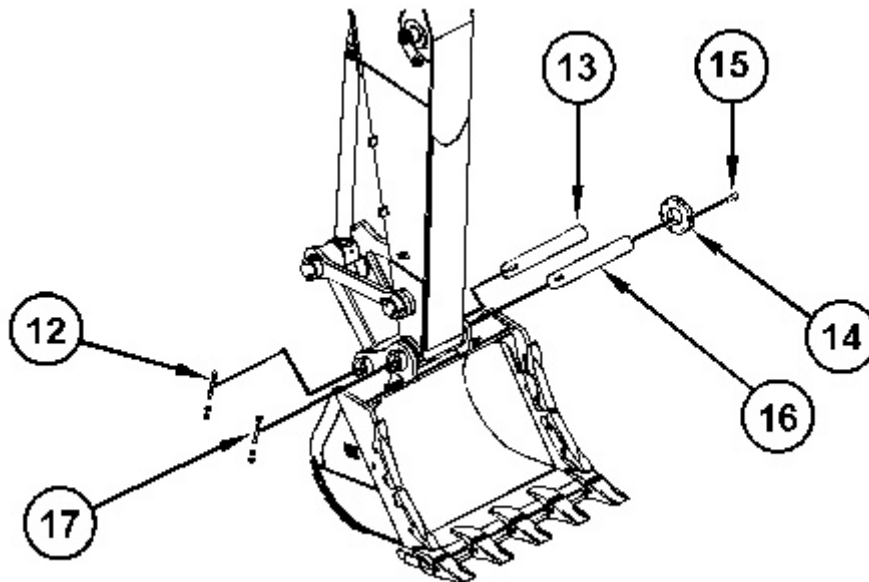

Illustration 15

g03822739

4. Install support pin (16). Put the retaining bolt hole that is in support pin (16) in alignment with the retaining bolt hole that is in the bucket.
5. Install the retaining bolt and nuts (17). Install adapter plate (14) without the shims, and without bolts (15) that hold adapter plate (14).
6. Refer to Operation and Maintenance Manual, "Bucket Linkage - Inspect/Adjust" in order to adjust the bucket clearance.

7. Slide O-ring seals (11) in position over the pin joints between the bucket and the stick.
 8. Start the engine and position the bucket linkage into the bucket until the pin bores are in alignment with each other. Stop the engine.
 9. Install support pin (13). Put the retaining bolt hole that is in the bucket pin in alignment with the retaining bolt hole that is in the bucket.
 10. Install the retaining bolt and nuts (12).
 11. Slide the O-ring seals (11) over the pin joints between the bucket and the link assembly.
-

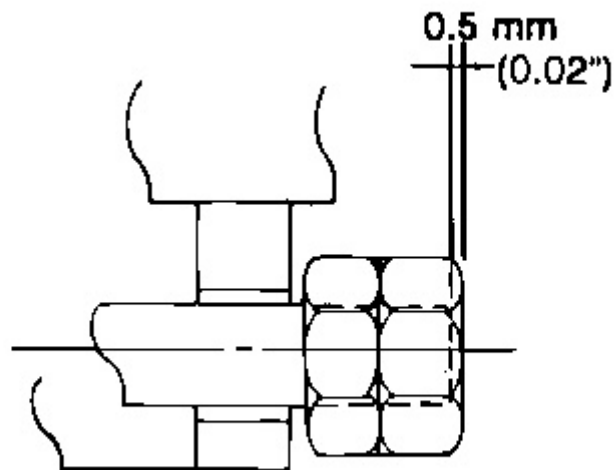

Illustration 16

g00510030

12. Tighten retaining nuts (12) and (17). Position the outside nut even with the end of the retaining bolt or 0.5 mm (0.02 inch) beyond the end of the retaining bolt. Tighten the inside nut against the outside nut.
 13. Lubricate the bucket pins. Refer to Operation and Maintenance Manual, "Bucket Linkage - Lubricate" or Operation and Maintenance Manual, "Boom, Stick, and Bucket Linkage - Lubricate".
-

Product: EXCAVATOR

Model: M318 EXCAVATOR 6ES

Configuration: M318 Excavator 6ES00001-UP (MACHINE) POWERED BY 3116 Engine

Operation and Maintenance Manual M318 and M320 Excavators

Media Number -SEBU6879-06

Publication Date -01/12/2000

Date Updated -26/09/2002

s00037320

Foreword

SMCS - 6001-011; 6001; 6101; 6102; 6523

Literature Information

This manual should be stored in the operator's compartment in the literature holder or seat back literature storage area.

This manual contains safety information, operation instructions, transportation information, lubrication information and maintenance information.

Some photographs or illustrations in this publication show details or attachments that can be different from your machine. Guards and covers might have been removed for illustrative purposes.

Continuing improvement and advancement of product design might have caused changes to your machine which are not included in this publication. Read, study and keep this manual with the machine.

Whenever a question arises regarding your machine, or this publication, please consult your Cat dealer for the latest available information.

Safety

The safety section lists basic safety precautions. In addition, this section identifies the text and locations of warning signs and labels used on the machine.

Read and understand the basic precautions listed in the safety section before operating or performing lubrication, maintenance and repair on this machine.

Operation

The operation section is a reference for the new operator and a refresher for the experienced operator. This section includes a discussion of gauges, switches, machine controls, attachment controls, transportation and towing information.

Photographs and illustrations guide the operator through correct procedures of checking, starting, operating and stopping the machine.

Operating techniques outlined in this publication are basic. Skill and techniques develop as the operator gains knowledge of the machine and its capabilities.

Maintenance

The maintenance section is a guide to equipment care. The Maintenance Interval Schedule (MIS) lists the items to be maintained at a specific service interval. Items without specific intervals are listed under the "When Required" service interval. The Maintenance Interval Schedule lists the page number for the step-by-step instructions required to accomplish the scheduled maintenance. Use the Maintenance Interval Schedule as an index or "one safe source" for all maintenance procedures.

Maintenance Intervals

Use the service hour meter to determine servicing intervals. Calendar intervals shown (daily, weekly, monthly, etc.) can be used instead of service hour meter intervals if they provide more convenient servicing schedules and approximate the indicated service hour meter reading. Recommended service should always be performed at the interval that occurs first.

Under extremely severe, dusty or wet operating conditions, more frequent lubrication than is specified in the maintenance intervals chart might be necessary.

Perform service on items at multiples of the original requirement. For example, at every 500 service hours or 3 months, also service those items listed under every 250 service hours or monthly and every 10 service hours or daily.

California Proposition 65 Warning

Diesel engine exhaust and some of its constituents are known to the State of California to cause cancer, birth defects, and other reproductive harm.

Battery posts, terminals and related accessories contain lead and lead compounds. **Wash hands after handling.**

Certified Engine Maintenance

Proper maintenance and repair is essential to keep the engine and machine systems operating correctly. As the heavy duty off-road diesel engine owner, you are responsible for the performance of the required maintenance listed in the Owner Manual, Operation and Maintenance Manual, and Service Manual.

It is prohibited for any person engaged in the business of repairing, servicing, selling, leasing, or trading engines or machines to remove, alter, or render inoperative any emission related device or element of design installed on or in an engine or machine that is in compliance with the

regulations (40 CFR Part 89). Certain elements of the machine and engine such as the exhaust system, fuel system, electrical system, intake air system and cooling system may be emission related and should not be altered unless approved by Caterpillar.

Machine Capacity

Additional attachments or modifications may exceed machine design capacity which can adversely affect performance characteristics. Included would be stability and system certifications such as brakes, steering, and rollover protective structures (ROPS). Contact your Cat dealer for further information.

Cat Product Identification Number

Effective First Quarter 2001 the Cat Product Identification Number (PIN) has changed from 8 to 17 characters. In an effort to provide uniform equipment identification, Caterpillar and other construction equipment manufacturers are moving to comply with the latest version of the product identification numbering standard. Non-road machine PINs are defined by ISO 10261. The new PIN format will apply to all Cat machines and generator sets. The PIN plates and frame marking will display the 17 character PIN. The new format will look like the following:

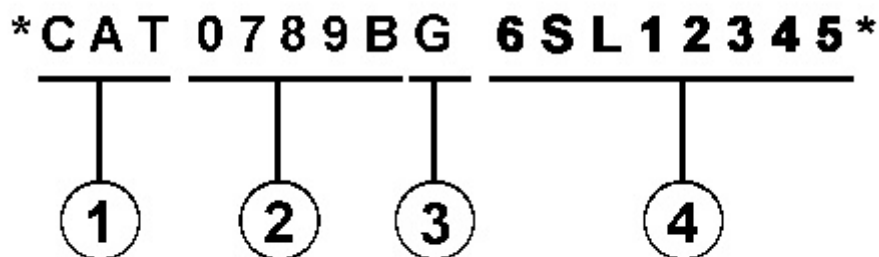

Illustration 1

g00751314

Where:

1. Caterpillar's World Manufacturing Code (characters 1-3)
2. Machine Descriptor (characters 4-8)
3. Check Character (character 9)
4. Machine Indicator Section (MIS) or Product Sequence Number (characters 10-17). These were previously referred to as the Serial Number.

Machines and generator sets produced before First Quarter 2001 will maintain their 8 character PIN format.

Components such as engines, transmissions, axles, etc. and work tools will continue to use an 8 character Serial Number (S/N).

Product: EXCAVATOR

Model: M318 EXCAVATOR 6ES

Configuration: M318 Excavator 6ES00001-UP (MACHINE) POWERED BY 3116 Engine

Operation and Maintenance Manual M318 and M320 Excavators

Media Number -SEBU6879-06

Publication Date -01/12/2000

Date Updated -26/09/2002

i01228107

Safety Signs and Labels

SMCS - 7000; 7405

There are several specific warning signs on this machine. The exact location of the hazards and the description of the hazards are reviewed in this section. Please become familiarized with all warning signs.

Make sure that all of the warning signs are legible. Clean the warning signs or replace the warning signs if you cannot read the words. Replace the illustrations if the illustrations are not visible. When you clean the warning signs, use a cloth, water and soap. Do not use solvent, gasoline, or other harsh chemicals to clean the safety signs. Solvents, gasoline, or harsh chemicals could loosen the adhesive that secures the warning sign. Loose adhesive will allow the warning sign to fall.

Replace any safety sign that is damaged, or missing. If a safety sign is attached to a part that is replaced, install a safety sign on the replacement part. Any Caterpillar dealer can provide new safety signs.

Do Not Operate

Thank you so much for reading.
Please click the “Buy Now!”
button below to download the
complete manual.



After you pay.

You can download the most
perfect and complete manual in
the world immediately.

Our support email:

ebooklibonline@outlook.com