

KEY	PART NO.	PART NAME	QTY	REMARKS
1	RE537149	VALVE	1	
2	R528254	SEAL	2	
3	R532306	AIR DUCT	1	(Air Throttle Inlet) SUB FOR R531284
4	19M8039	SCREW	3	M8 X 80
5	R533667	BRACKET	1	
6	19M7970	SCREW	1	M8 X 100
7	RE540860	TEMPERATURE SENSOR	1	
8	RE258807	TIE BAND	1	
9	19M7790	SCREW	2	M12 X 35
10	R532715	BRACKET	1	
11	24M7178	WASHER	3	10.500 X 30 X 2.500 mm
12	R186227	SCREW	1	SUB FOR 19M7799
13	RE537635	TEMPERATURE SENSOR	1	
14	19M7803	SCREW	8	M8 X 70
15	R532671	GASKET	1	SUB FOR R523520
16	R530859	INTAKE MANIFOLD	1	
17	R529807	STUD	3	
18	19M8006	SCREW	3	M8 X 120
19	19M7786	SCREW	11	M10 X 30
20	RE537639	MANIFOLD AIR PRESS. SENSOR	1	
21	R528478	GASKET	1	
22	19M7866	SCREW	3	M8 X 20
23	R532048	ADAPTER	1	SUB FOR R528480
24	R528481	GASKET	1	
25	R537140	AIR DUCT	1	MARKED R537204; SUB FOR R531337
26	57M9940	ELEC. CONNECTOR ACCESSORY	1	

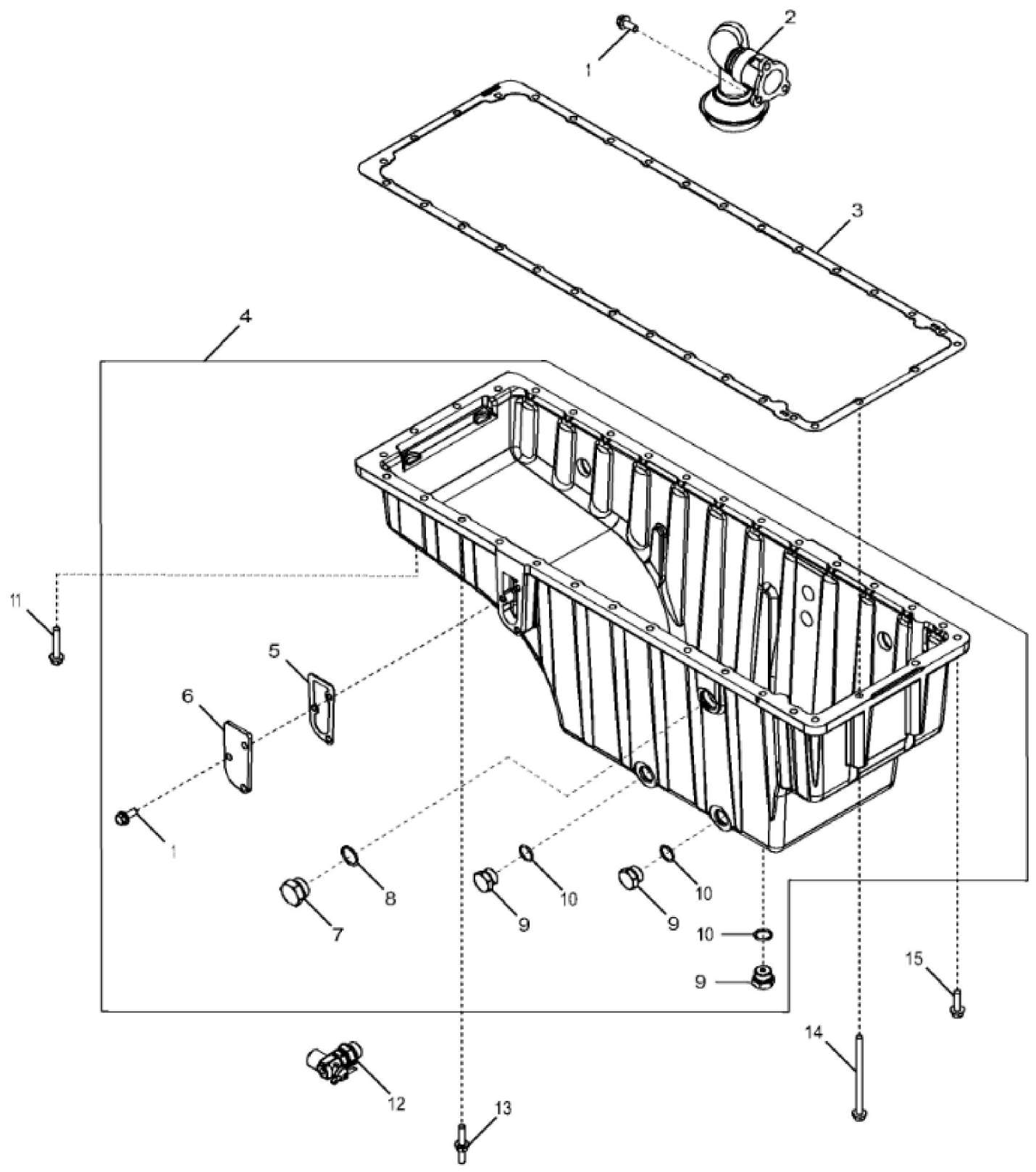

KEY	PART NO.	PART NAME	QTY	REMARKS	
1	19M7785	SCREW	9	M10 X 25	
2	RE539999	OIL PUMP INTAKE	1		
3	R528591	GASKET	1		
4	RE539461	OIL PAN	1	MARKED R528566; INCLUDES (6) 19M7785	
5	RE63439	GASKET	2		
6	R519285	COVER	2		
7	R36636	FITTING PLUG	3		
8	R29936	O-RING	3		
9	R27175	DRAIN PLUG	4		
10	R56751	O-RING	4		
11	19M8528	SCREW	2	M10 X 55	
12	RE509381	DRAIN VALVE	1		
13	R531391	STUD	2		
14	19M7958	SCREW	2	M10 X 150	
15	19M7835	SCREW	26	M10 X 35	

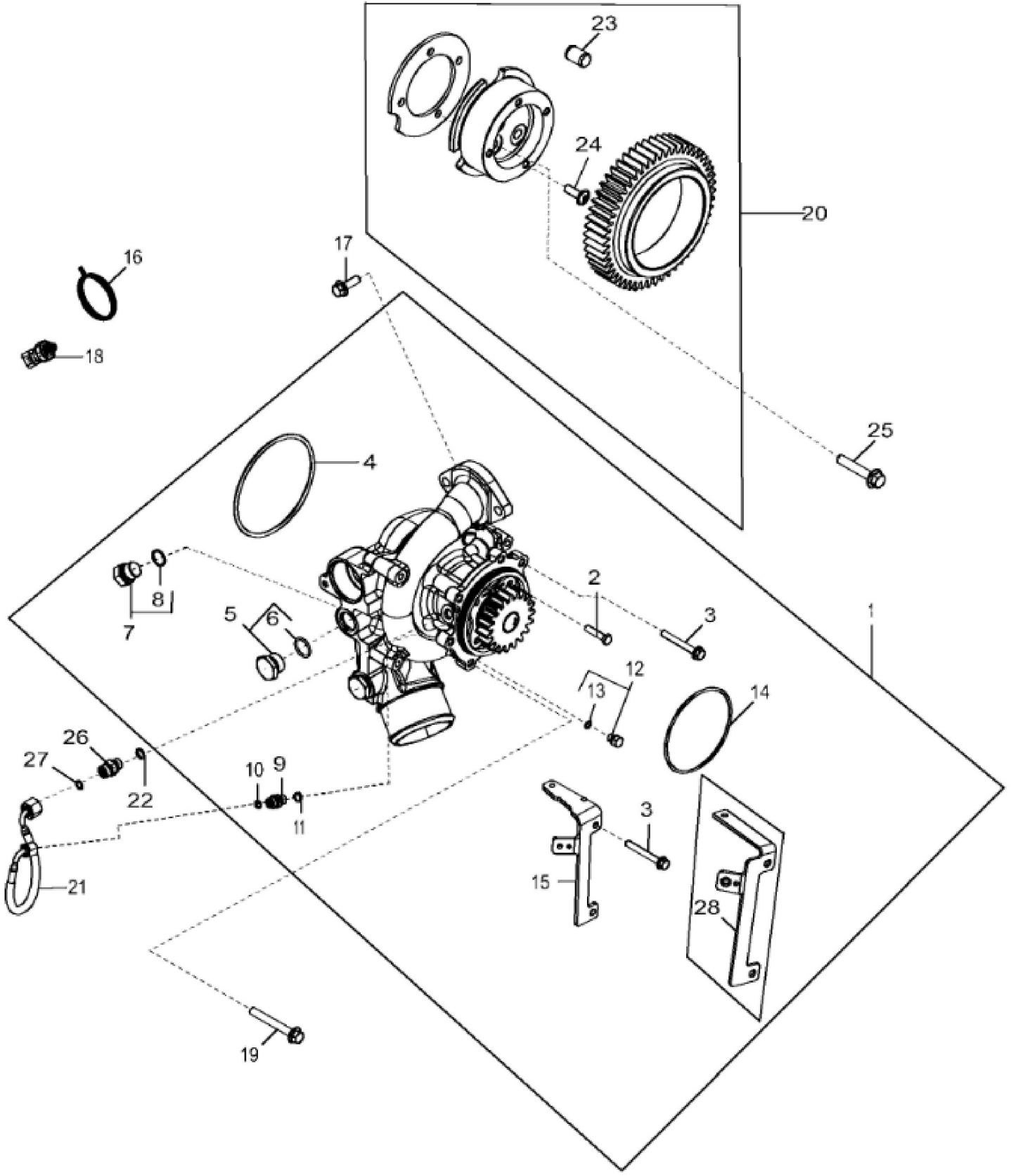

KEY	PART NO.	PART NAME	QTY	REMARKS
1	RE558358	WATER PUMP	1	SUB FOR RE557276
1	SE502785	WATER PUMP REMAN	1	REMAN FOR RE558358, RE548537 AND RE557276
2	19M8008	CAP SCREW	4	M8 X 35
3	19M8987	SCREW	4	M8 X 65
4	R532585	O-RING	1	
5	R226925	DRAIN PLUG	2	
6	51M7047	O-RING	2	23.600 X 2.900 mm
7	RE46687	DRAIN PLUG	1	
8	51M7045	O-RING	1	19.300 X 2.200 mm
9	38H5001	ADAPTER FITTING	1	
10	T77814	O-RING	1	
11	51M7040	O-RING	1	9.300 X 2.200 mm
12	RE60071	FITTING	1	
13	51M7039	O-RING	1	8.100 X 1.600 mm
14	R515388	O-RING	1	
15	DZ100249	BRACKET	1	
16	R528498	SEAL	1	
17	19M7786	SCREW	2	M10 X 30
18	RE539840	PRESSURE SENSOR	1	(Coolant Pressure Sensor)
19	19M7810	SCREW	5	M10 X 80
20	RE559569	IDLER GEAR	1	SUB FOR RE548528 AND RE548321
21	RE544373	OIL LINE	1	
22	51M7095	O-RING	1	11.300 X 2.200 mm
23	44M7151	DOWEL PIN	1	20 X 30 mm
24	19M8883	SCREW	4	M10 X 30
25	R529574	CAP SCREW	3	
26	38H5002	ADAPTER FITTING	1	
27	R63548	O-RING	1	
28	RE548124	BRACKET	1	ORDER DZ100249

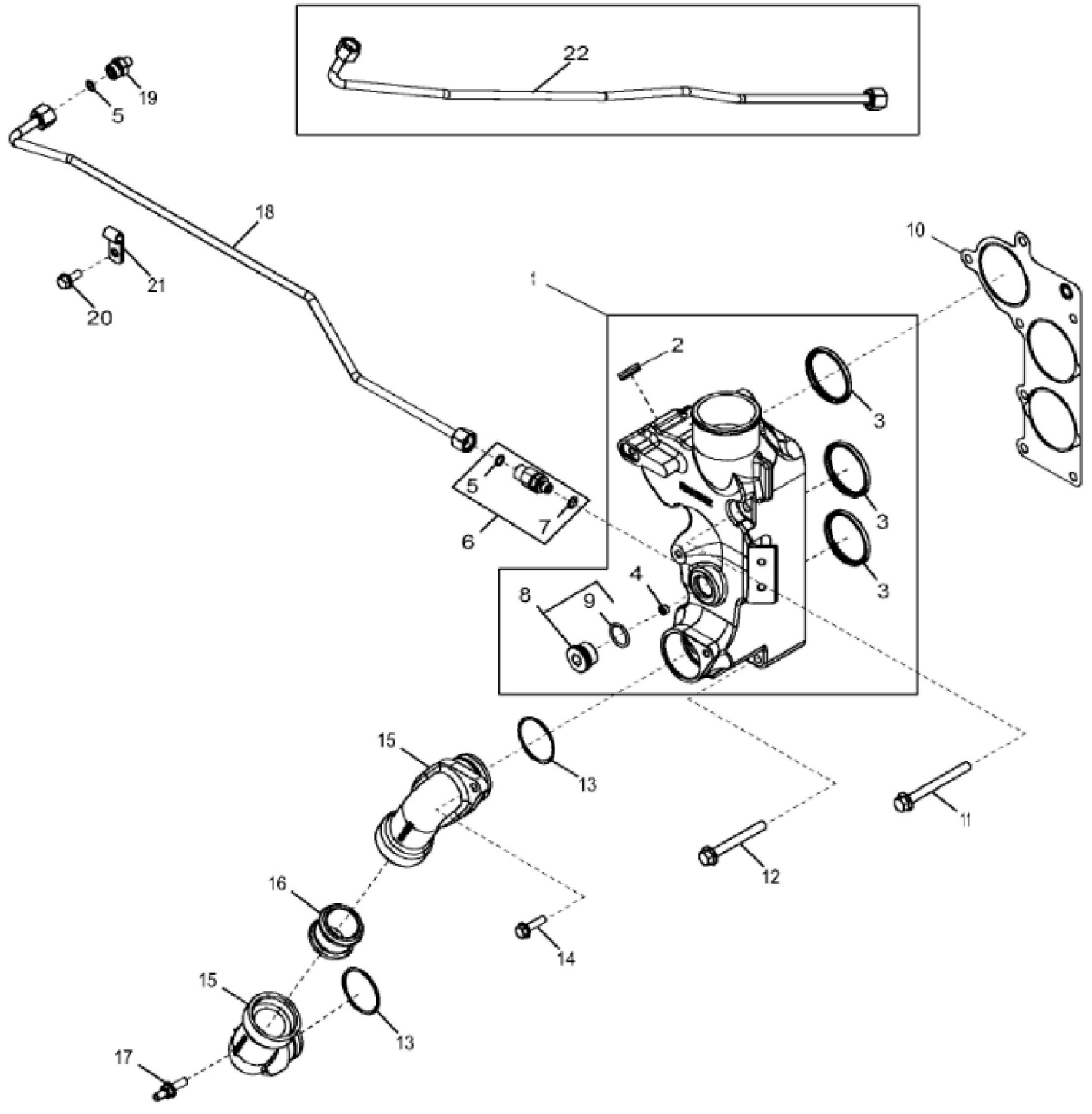

Thank you so much for reading.
Please click the “Buy Now!”
button below to download the
complete manual.



After you pay.

You can download the most
perfect and complete manual in
the world immediately.

Our support email:

ebooklibonline@outlook.com