

## ROCKER ARM COVER

| KEY | PART NO. | PART NAME     | QTY | REMARKS                          |  |
|-----|----------|---------------|-----|----------------------------------|--|
| 1   | RE529871 | ELBOW FITTING | 1   | SUB FOR RE527976                 |  |
| 2   | T122075  | O-RING        | 1   |                                  |  |
| 3   | 19M8291  | SCREW         | 15  | M8 X 35                          |  |
| 4   | RE536705 | COVER         | 1   | MARKED R545610; SUB FOR RE529972 |  |
| 5   | R523317  | BREATHER      | 1   | SUB FOR R518264                  |  |
| 6   | RE526690 | CAP SCREW     | 2   |                                  |  |
| 7   | RE526689 | CAP SCREW     | 1   |                                  |  |
| 8   | R527884  | GASKET        | 1   |                                  |  |

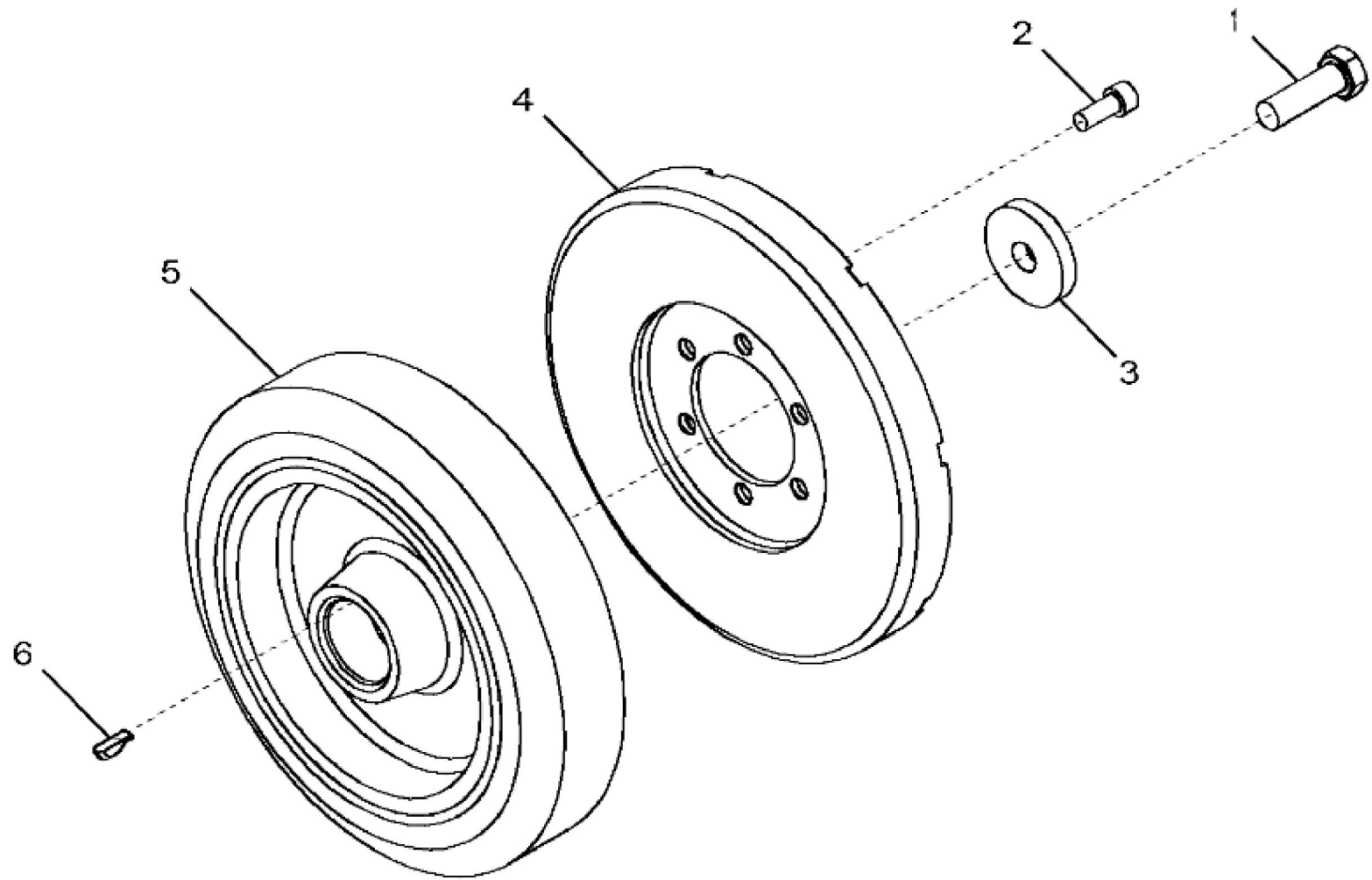

1341\_RE523047\_PCD

## DAMPER

| KEY | PART NO. | PART NAME        | QTY | REMARKS  |  |
|-----|----------|------------------|-----|----------|--|
| 1   | 19M8889  | CAP SCREW        | 1   | M16 X 50 |  |
| 2   | 19M8533  | SCREW            | 6   | M10 X 25 |  |
| 3   | R26333   | WASHER           | 1   |          |  |
| 4   | RE57604  | TORSIONAL DAMPER | 1   |          |  |
| 5   | RE520465 | TORSIONAL DAMPER | 1   |          |  |
| 6   | R523306  | KEY              | 1   |          |  |

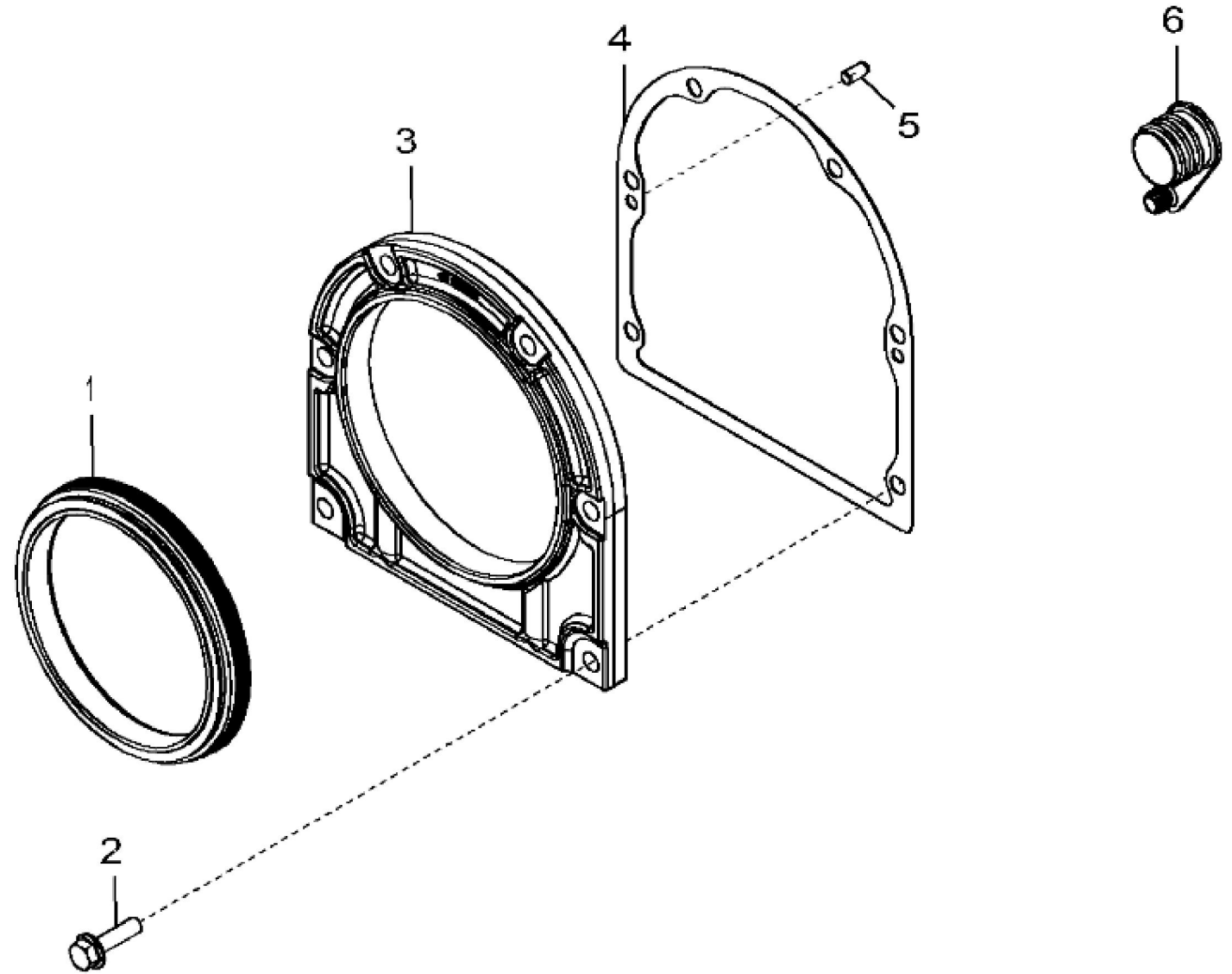

## FLYWHEEL HOUSING

| KEY | PART NO. | PART NAME | QTY | REMARKS                                    |  |
|-----|----------|-----------|-----|--------------------------------------------|--|
| 1   | RE520036 | SEAL      | 1   |                                            |  |
| 2   | 19M7868  | SCREW     | 6   | M8 X 30                                    |  |
| 3   | R531312  | HOUSING   | 1   | MARKED R545426; SUB FOR R530233 OR R531570 |  |
| 4   | R522768  | GASKET    | 1   | SUB FOR R520504                            |  |
| 5   | F1743R   | DOWEL PIN | 2   |                                            |  |
| 6   | R121929  | PLUG      | 1   |                                            |  |

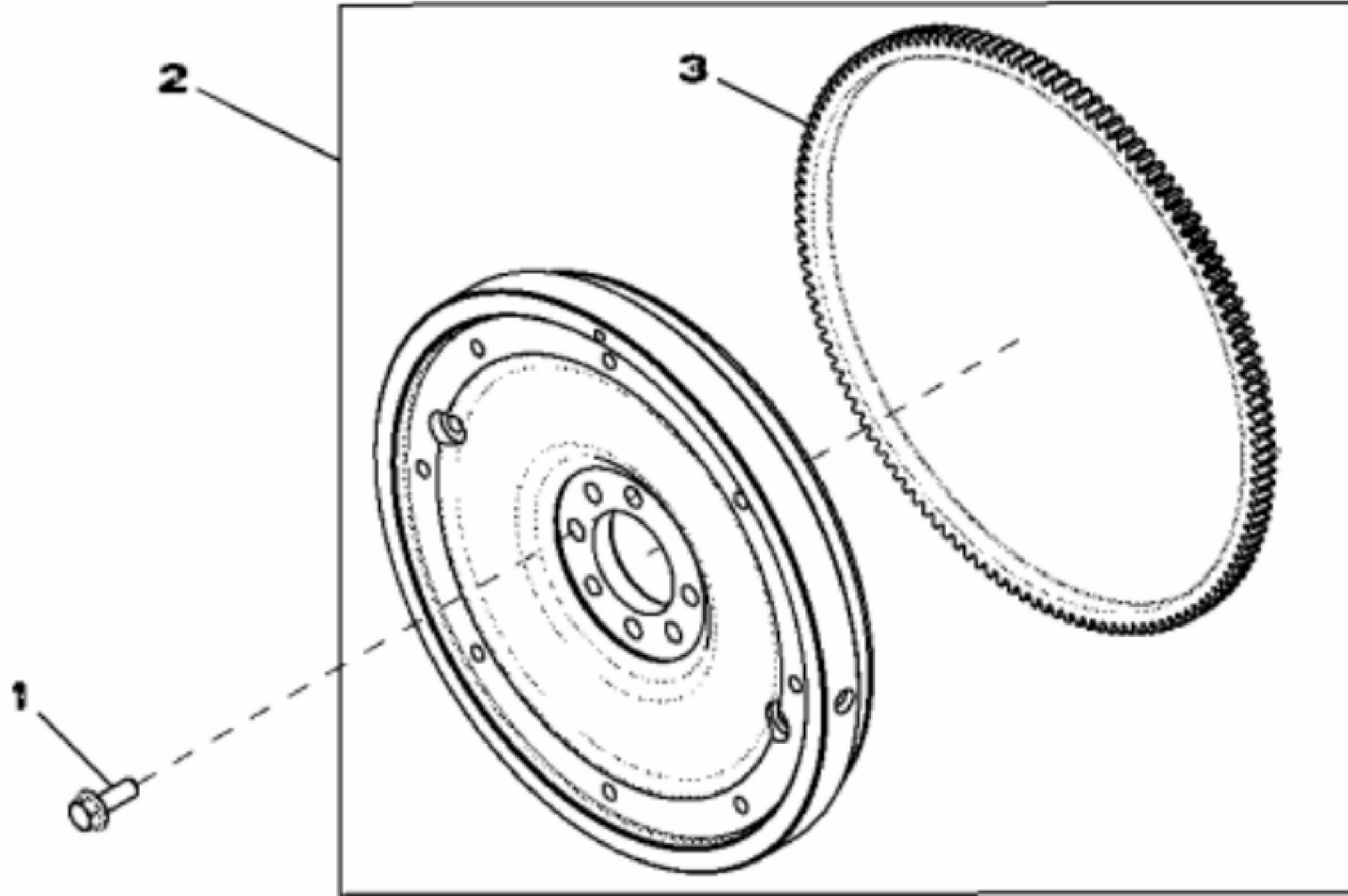

RE522627PCDA02

Thank you so much for reading.  
Please click the “Buy Now!”  
button below to download the  
complete manual.



After you pay.

You can download the most  
perfect and complete manual in  
the world immediately.

Our support email:

[ebooklibonline@outlook.com](mailto:ebooklibonline@outlook.com)