

John Deere > Agriculture >TRACTOR >8345R - TRACTOR >8345R Tractor (S.N. 100000- )(Engine: 6090HBM02, 6090HBM03, 6090HBM04, 6090HBM05) (South America Edition) >23 ENGINE 6090HBM02-DZ10414 >ST130073 - 1102 ROCKER ARM COVER

KEY	PART NO.	PART NAME	QTY	REMARKS	
1	RE529871	ELBOW FITTING	1	SUB FOR RE527976	
2	T122075	O-RING	1		
3	19M8291	SCREW	15	M8 X 35	
4	RE536705	COVER	1	MARKED R545610; SUB FOR RE529972	
5	R523317	BREATHER	1	SUB FOR R518264	
6	RE526690	CAP SCREW	2		
7	RE526689	CAP SCREW	1		
8	R527884	GASKET	1		

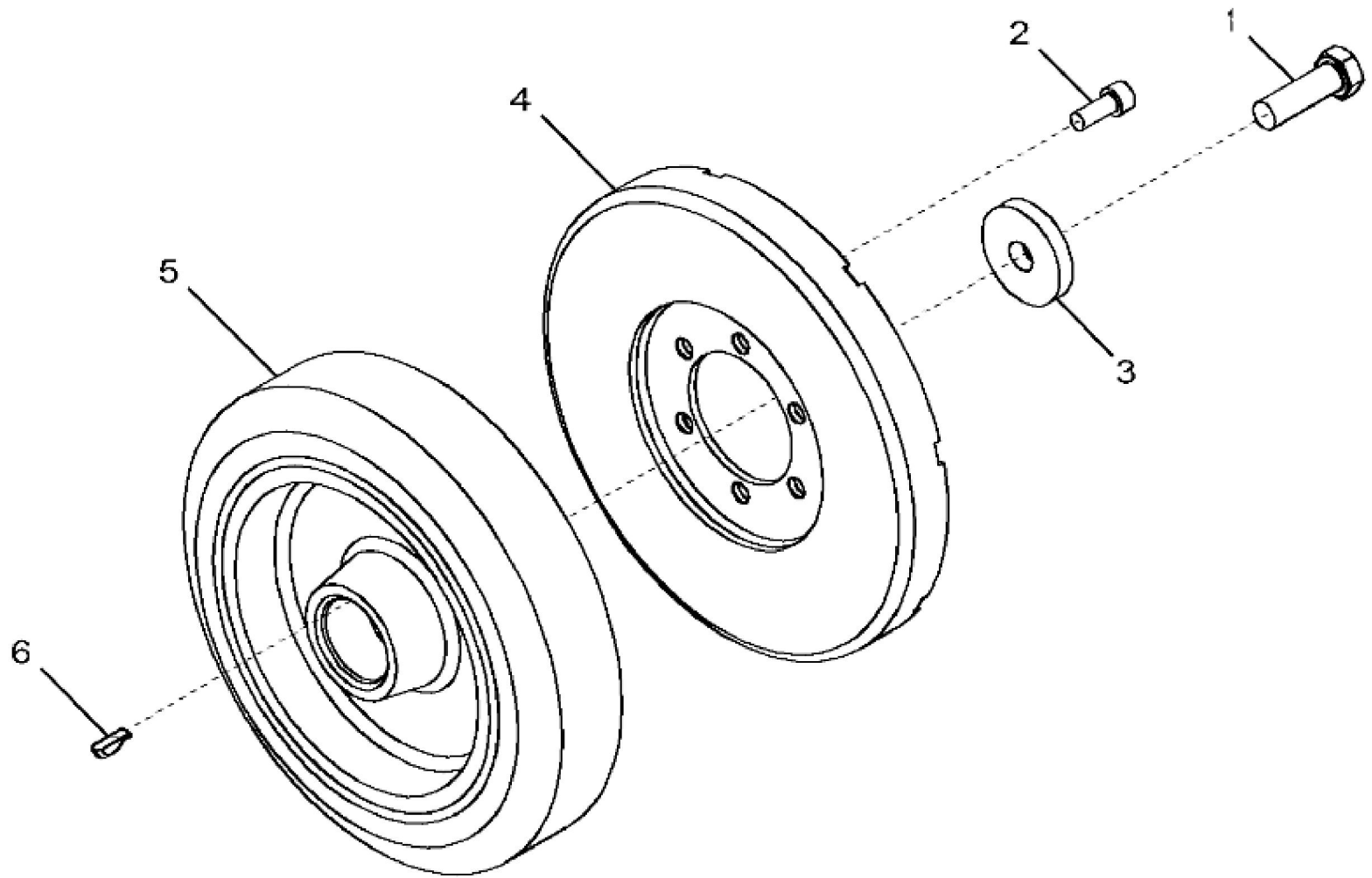

1341\_RE523047\_PCD

John Deere > Agriculture > TRACTOR > 8345R - TRACTOR > 8345R Tractor (S.N. 100000- )(Engine: 6090HBM02, 6090HBM03, 6090HBM04, 6090HBM05) (South America Edition) > 23 ENGINE 6090HBM02-DZ10414 > ST142017 - 1341 DAMPER

KEY	PART NO.	PART NAME	QTY	REMARKS	
1	19M8889	CAP SCREW	1	M16 X 50	
2	19M8533	SCREW	6	M10 X 25	
3	R26333	WASHER	1		
4	RE57604	TORSIONAL DAMPER	1		
5	RE520465	TORSIONAL DAMPER	1		
6	R523306	KEY	1		

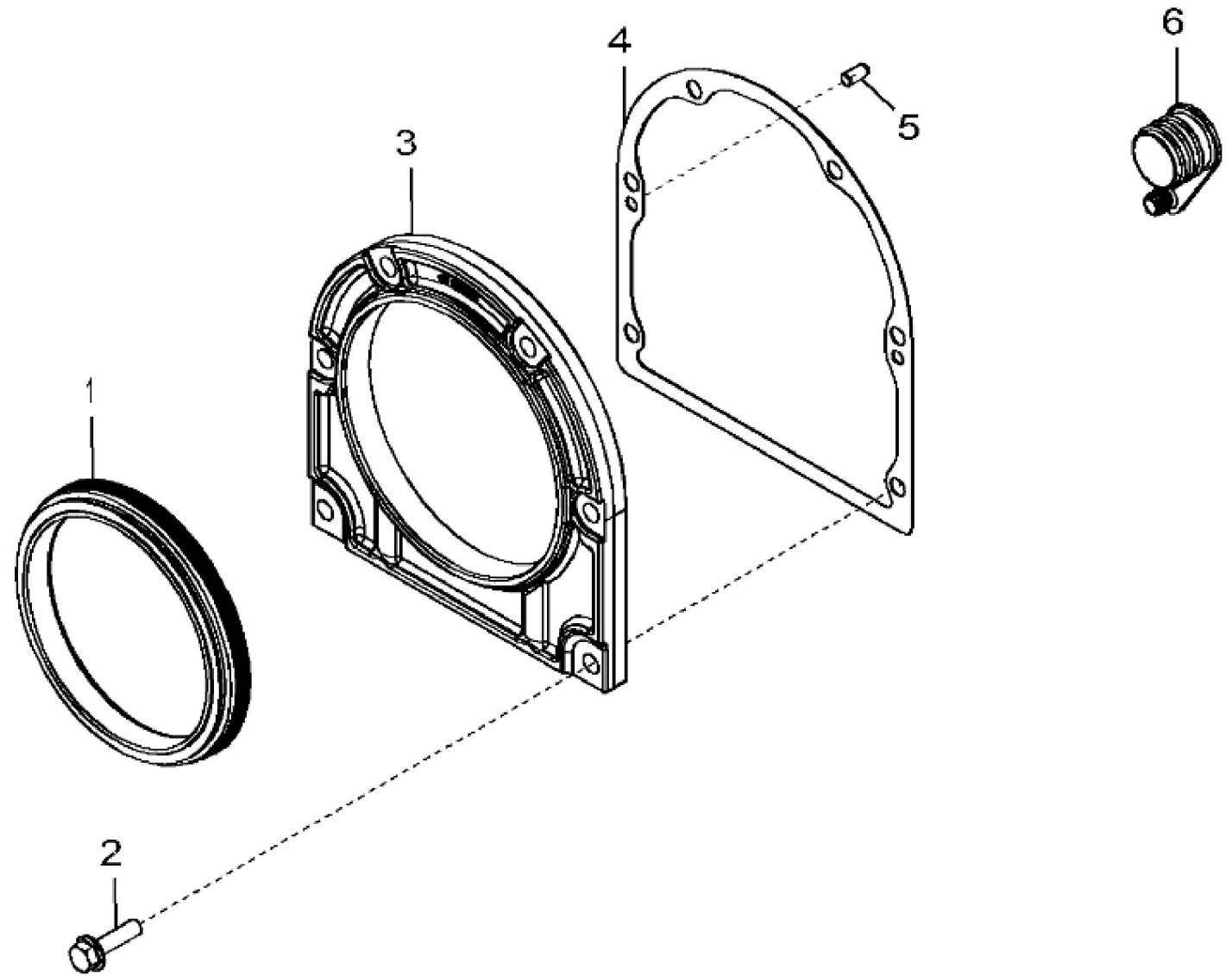

John Deere > Agriculture >TRACTOR >8345R - TRACTOR >8345R Tractor (S.N. 100000- )(Engine: 6090HBM02, 6090HBM03, 6090HBM04, 6090HBM05) (South America Edition) >23 ENGINE 6090HBM02-DZ10414 >ST386277 - 1499 FLYWHEEL HOUSING

KEY	PART NO.	PART NAME	QTY	REMARKS	
1	RE520036	SEAL	1		
2	19M7868	SCREW	6	M8 X 30	
3	R531312	HOUSING	1	MARKED R545426; SUB FOR R530233 OR R531570	
4	R522768	GASKET	1	SUB FOR R520504	
5	F1743R	DOWEL PIN	2		
6	R121929	PLUG	1		

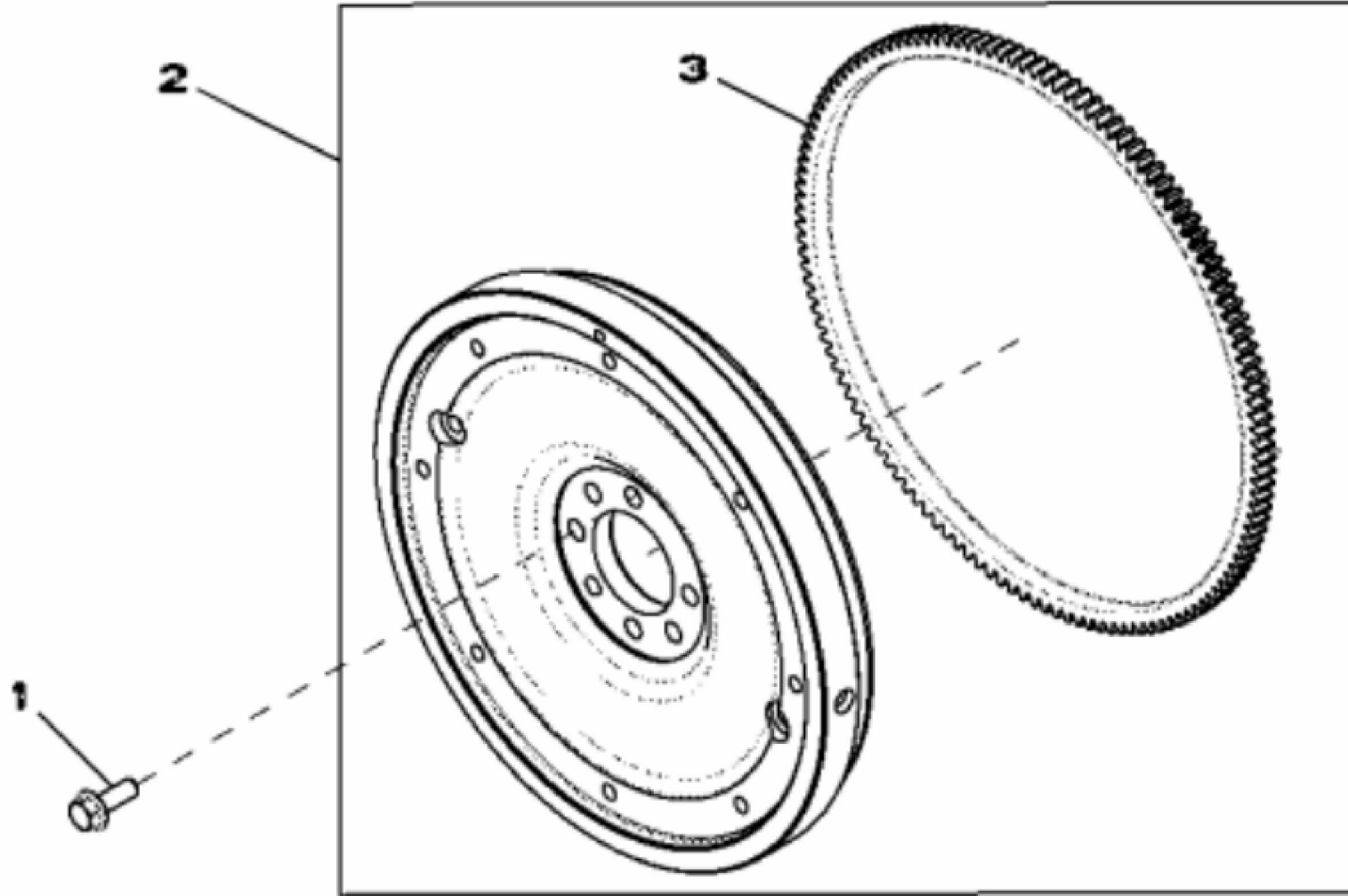

RE522627PCDA02

Thank you so much for reading.  
Please click the “Buy Now!”  
button below to download the  
complete manual.



After you pay.

You can download the most  
perfect and complete manual in  
the world immediately.

Our support email:

[ebooklibonline@outlook.com](mailto:ebooklibonline@outlook.com)