

R33971

KEY	PART NO.	PART NAME	QTY	REMARKS	
1	R495R	O-RING	1		
2	T20074	TUBE	1		
3	R40791	CLAMP	1		
4	24H1685	WASHER	1	11/32" X 47/64" X 0.083"	
5	19H1813	CAP SCREW	1	5/16" X 5/8"	
6	AT18016	VALVE COVER	1		
7	T24151	CLAMP	1		
8	AR45530	SCREW WITH WASHER	6	(SUB AR103811)	
9	T20111	GASKET	1	(SUB AR102261)	
10	A3910R	PLUG	2	(SUB N102039)	
11	AR70583	CYLINDER HEAD	1	(SUB FOR AR70582) (SUB RE56309)	
12	CD13979	VALVE SEAT INSERT	3	(SUB R97778)	
13	R80241	GASKET	1	(STD) (SUB FOR R64151 OR R59447)	
14	T20168	WASHER	14		
15	R53223	CAP SCREW	14		
16	RE51774	SENSOR	1	(WATER TEMPERATURE GAUGE) (SUB FOR AL24527)	

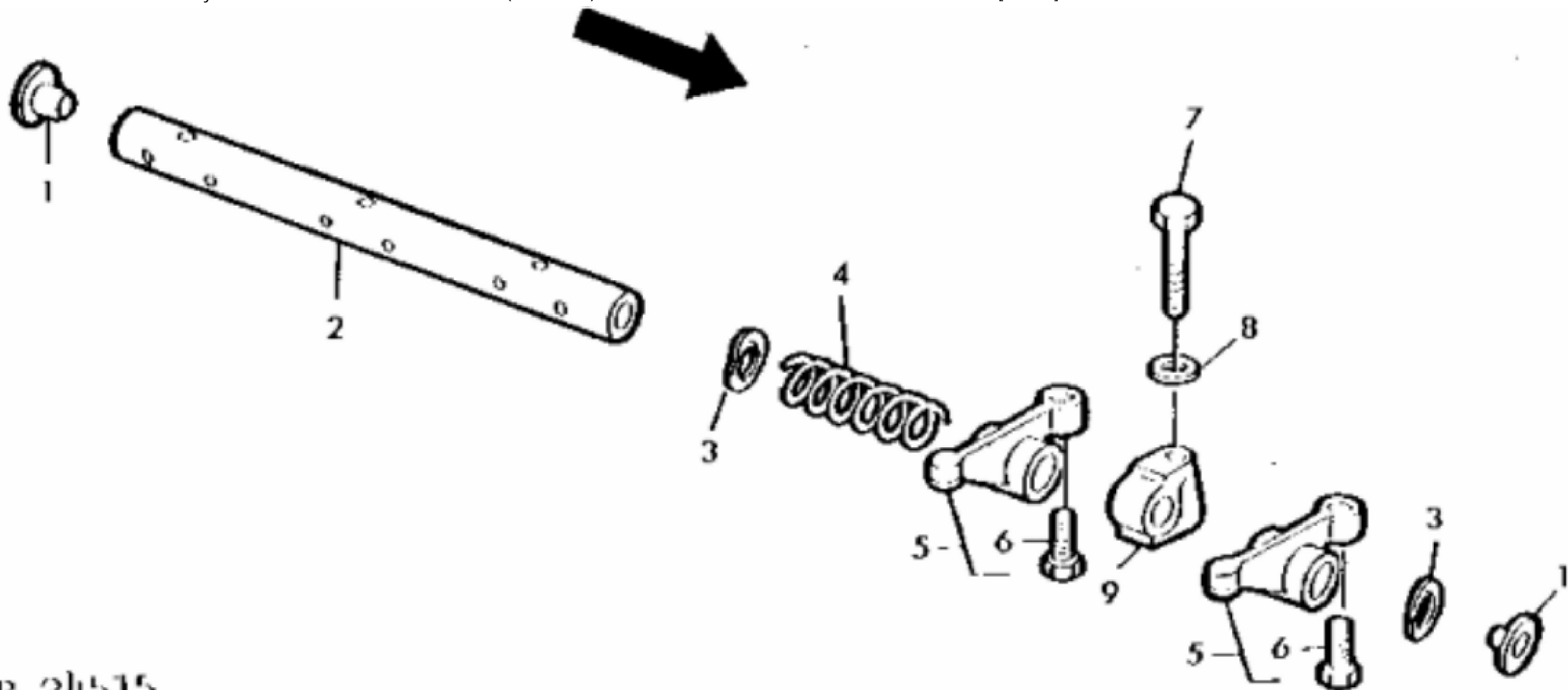

R 24515

KEY	PART NO.	PART NAME	QTY	REMARKS	
1	R54565	PLUG	2		
2	R54985	ROCKER ARM SHAFT	1	(SUB DD12119)	
3	T20316	WASHER	2		
4	T20314	SPRING	2		
5	RE31973	ROCKER ARM	6	(SUB FOR AT31250, AR103769 OR RE19031)	
6	SCREW	1	(ORDER RE31973)	
7	19H1733	CAP SCREW	3	3/8" X 2-1/2"	
8	24M7106	WASHER	3	10 X 18 X 2.500 MM	
9	T20315	SUPPORT	3		

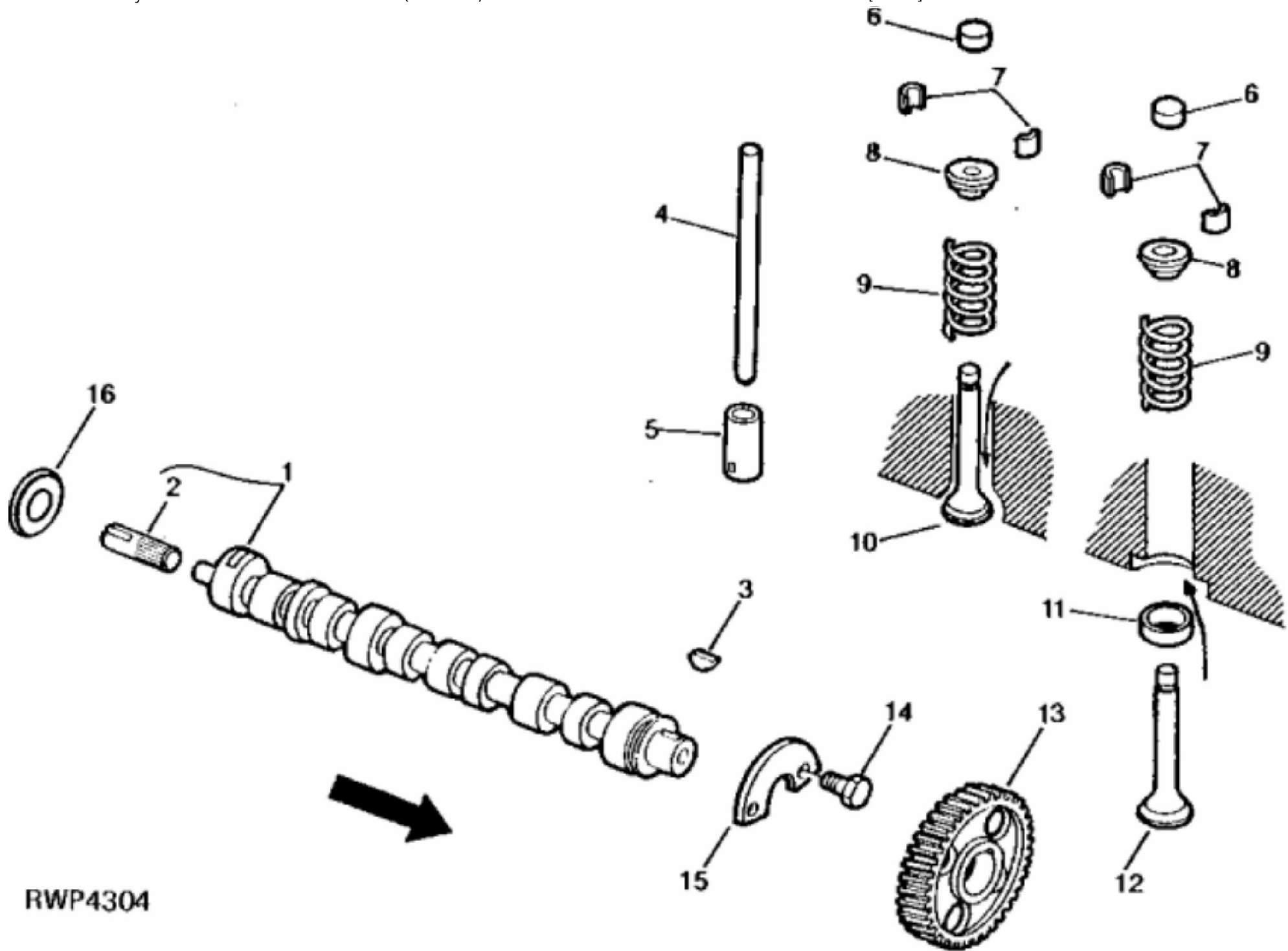

RWP4304

KEY	PART NO.	PART NAME	QTY	REMARKS
1	AT18053	CAMSHAFT	1	(SUB FOR AT18055) (SUB R81513 AND R82819)
2	T20071	DRIVE SHAFT	1	
3	T28041	SHAFT KEY	1	
4	T20310	PIN	6	(SUB R82896)
5	T20073	TAPPET	6	
6	T20129	CAP	6	
7	T20077	RETAINER	12	
8	R41412	CAP	6	(SUB FOR T20176)
9	R26125	SPRING	6	
10	R79623	INTAKE VALVE	3	STANDARD, (SUB FOR R52251)
10	R79628	INTAKE VALVE	3	0.08MM (.003") OS STEM, (SUB FOR R57332)
10	R57334	INTAKE VALVE	3	0.38MM (.015") OS STEM, (SUB R79629)
10	R79630	INTAKE VALVE	3	0.76MM (.030") OS STEM, (SUB FOR R57336)
11	CD13979	VALVE SEAT INSERT	3	(SUB R97778)
12	R79624	EXHAUST VALVE	3	(SUB FOR R52252)
12	R79625	EXHAUST VALVE	3	0.08MM (.003") OS STEM, (SUB FOR R57333)
12	R57335	EXHAUST VALVE	3	0.38MM (.015") OS STEM, (SUB R79626)
12	R79627	EXHAUST VALVE	3	0.76MM (.030") OS STEM, (SUB FOR R57337)
13	T20070	HELICAL GEAR	1	
14	19H1669	CAP SCREW	2	7/16" X 1-3/4"
15	T20072	PLATE	1	THRUST
16	T20304	WASHER	1	

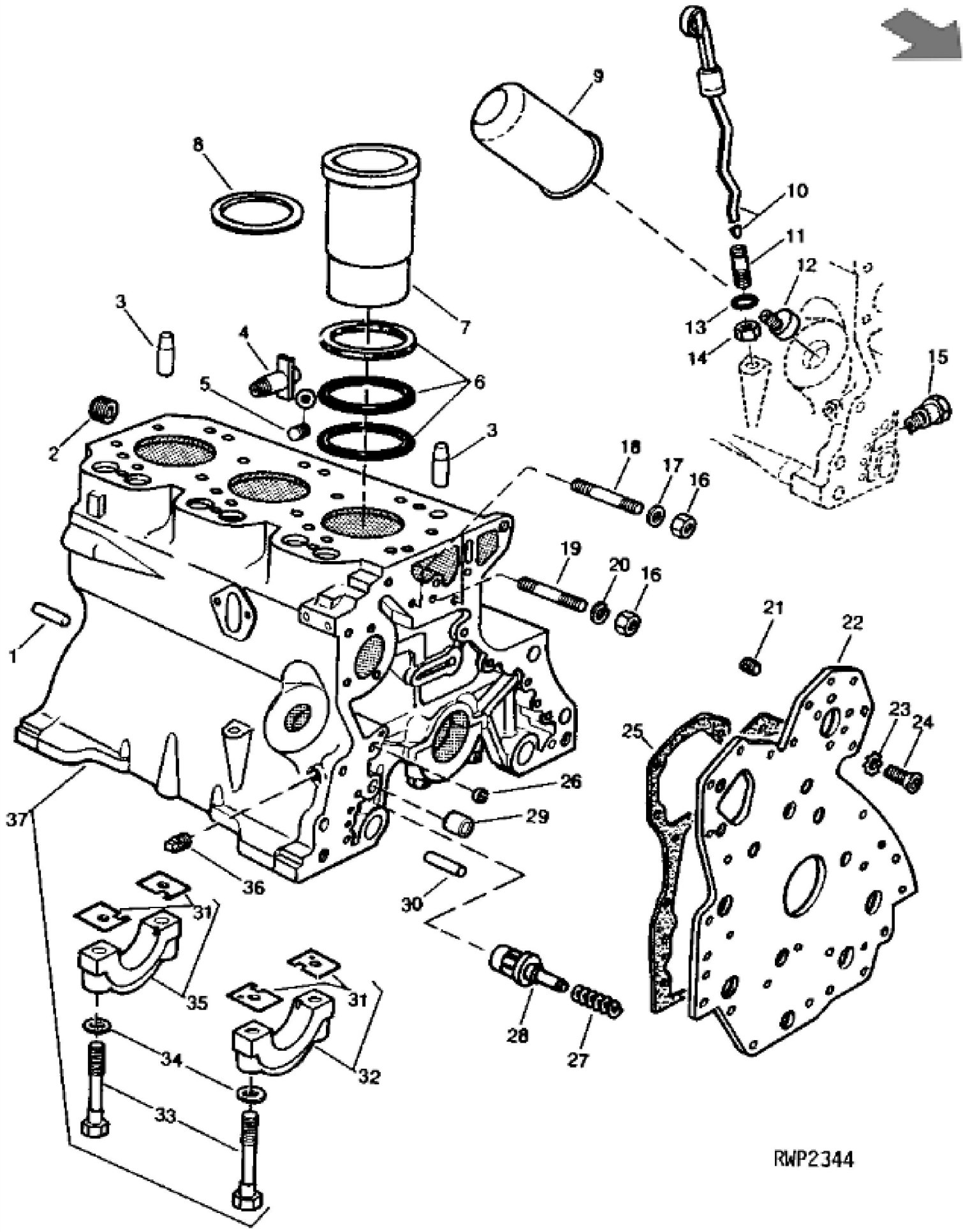

RWP2344

Thank you so much for reading.
Please click the “Buy Now!”
button below to download the
complete manual.



After you pay.

You can download the most
perfect and complete manual in
the world immediately.

Our support email:

ebooklibonline@outlook.com