

Section: ENGINE

**CRANKCASE**

Fig.	P/n	QTY	Name
------	-----	-----	------

Notes:  
[XT-910.6]

1	0.337.0050.6		gasket set - FOR ENGINE MOUNTING
2	0.007.1102.6/20	1	crankcase * 2725 <= x XT-910.6 - N.6 011.0183.0/10 - N.12 2.1539.193.0 * => 2726 - 3726 <= x XT-910.6 - N.24 - 012.2673.0
3	0.065.1112.7	1	support
4	2.1699.165.0	1	bush 12.3x15x16
5	0.007.0848.3/10	1	support
6	2.1699.165.0	1	bush 12.3x15x16
7	0.065.1141.0	1	special bushing 59X55X30
8	0.065.1140.0	6	special bushing 59X55X20
9	0.066.1151.0	1	pin
10	2.3130.001.1	14	plug 1/8" gas
11	2.3130.002.1	2	plug 1/4" gas
12	2.3130.003.1	8	plug 3/8" gas
15	2.3179.012.0	1	plug 60
16	0.065.1117.0	14	screw m 12 x 100
17	0.065.1114.0/10	5	support
18	2.3199.405.2	1	plug m 28 p.1.5
19	2.0432.003.7	18	stud bolt m 8 p.1.25 / p.1 x 20
20	2.1559.188.2	6	bush 11.4 x 14 x16
21	2.1519.096.0/20	18	special oil seal 107.67x1.78 2725 <= x XT-910.6
21	2.1539.193.0	12	special oil seal 107.62x2.62 => 2726 x XT-910.6
22	0.009.7500.0/10	6	engine cylinder 1024 <= = A
22	0.011.0183.0/20	6	engine cylinder => 2726 x XT-910.6
22	0.011.0582.0	6	engine cylinder = B => 1025 - 2725 <= x XT-910.6
23	2.1549.154.2	6	bush 4.8x5.8x16
24	2.1560.010.0	1	gasket 14.2 x 20
25	2.3199.292.0	1	plug 1/4" gas
26	2.0112.511.1	8	screw m 14 p.2 x 30
27	2.1651.912.0	2	cylindrical plug 12x28
28	2.1651.917.0	1	cylindrical plug 12x40
29	2.0432.257.7	1	stud bolt m 12 p.1.75 - 1.25 x 30

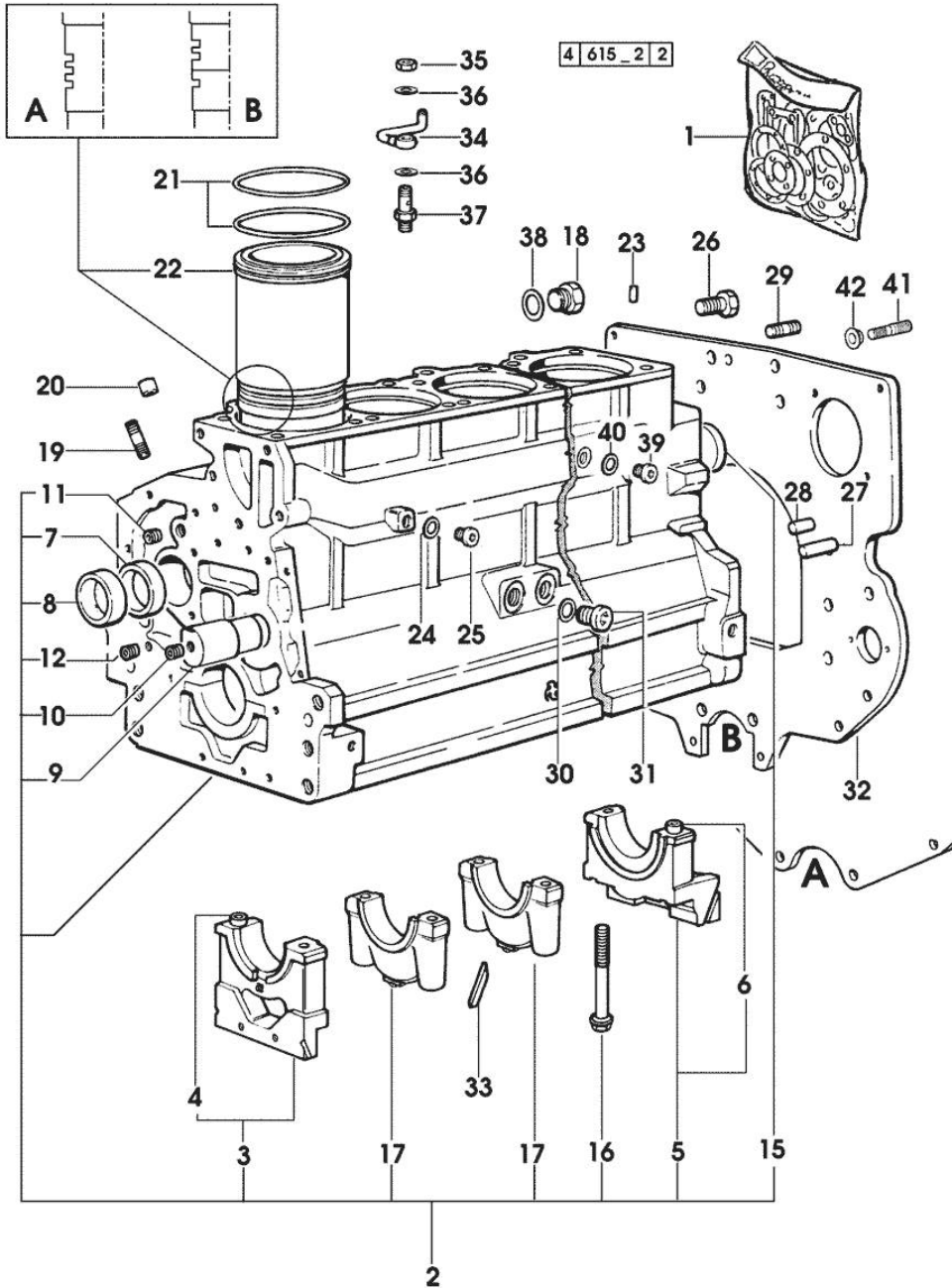

Section: ENGINE  
**CRANKCASE**

Fig.	P/n	QTY	Name
30	2.1560.017.0	1	gasket 22.2 x 27
31	2.3120.002.4	1	plug m 22 x 1.5
32	0.007.0805.0/20	1	flange (...) <= A
32	0.010.7201.0	1	flange => (...) = B
33	0.066.1152.0/10	4	gasket
34	0.086.1550.2	6	sprayer nozzle
35	2.1099.108.2	6	special nut m 10 p.1
36	2.1560.006.0	12	gasket 10.2 x 16
37	0.065.1160.3/20	6	valve
38	2.1532.072.0	1	oil seal 26.70x1.78
39	2.3120.101.0	1	plug m 18 p.1.5 => 2726 x XT-910.6
40	2.1560.014.0	1	washer 18.2 x 24
41	2.0439.250.7	1	stud bolt m 12 / m 10 x 30
42	0.011.9294.0/10	1	bush

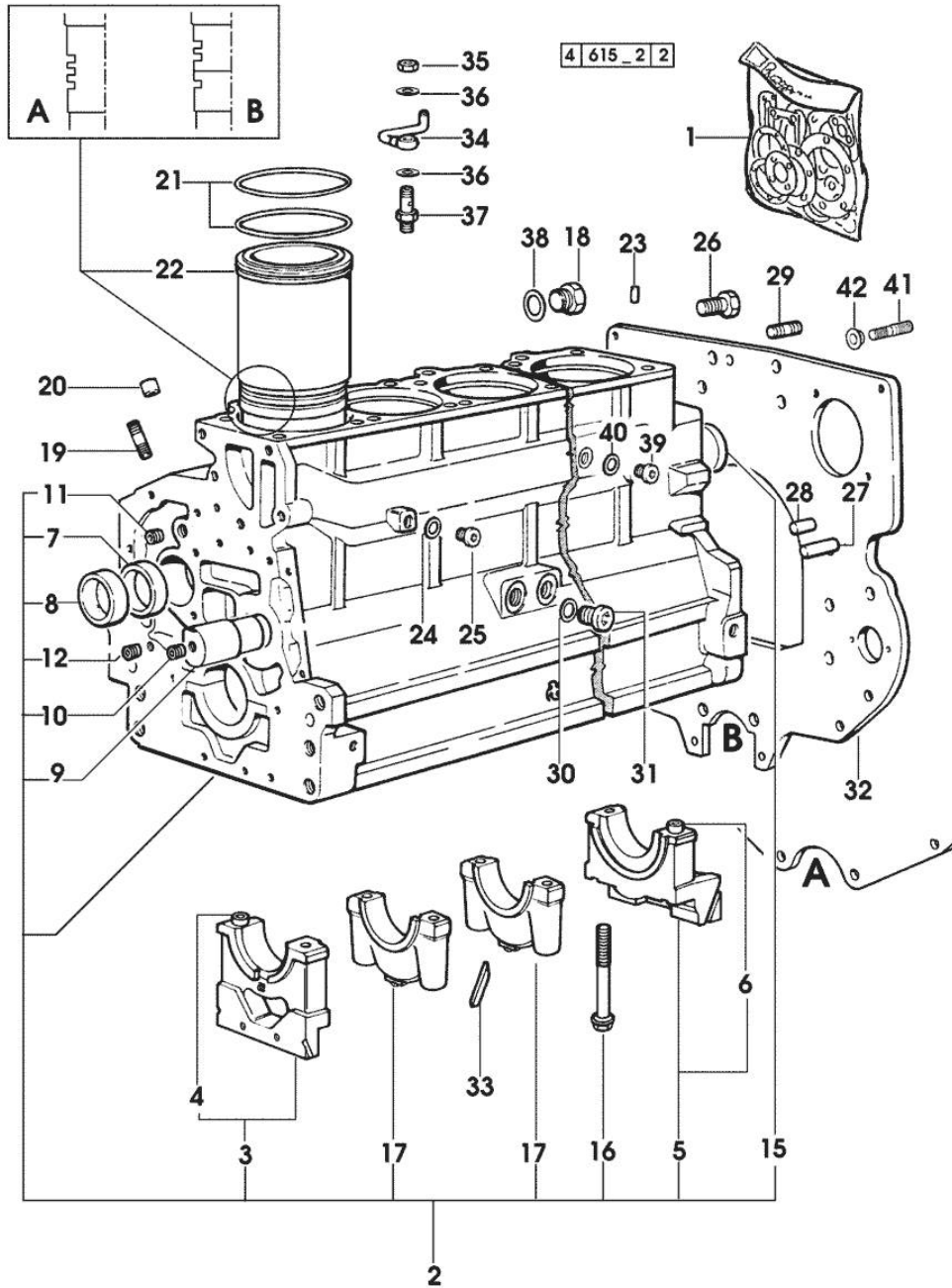

Section: ENGINE  
**TIMING CASE**

Fig.	P/n	QTY	Name
------	-----	-----	------

Notes:  
 [XT-910.6]

1	0.007.1262.3/50	1	guard
2	0.007.1271.0/10	1	small column m 8 p.1.25 / L = mm 60
3	0.007.1272.0/10	2	small column m 8 p.1.25 / L = mm 50
5	2.1310.004.2	3	flat washer 8.4x17
7	2.0112.205.2	3	screw m 8 p.1.25 x 16

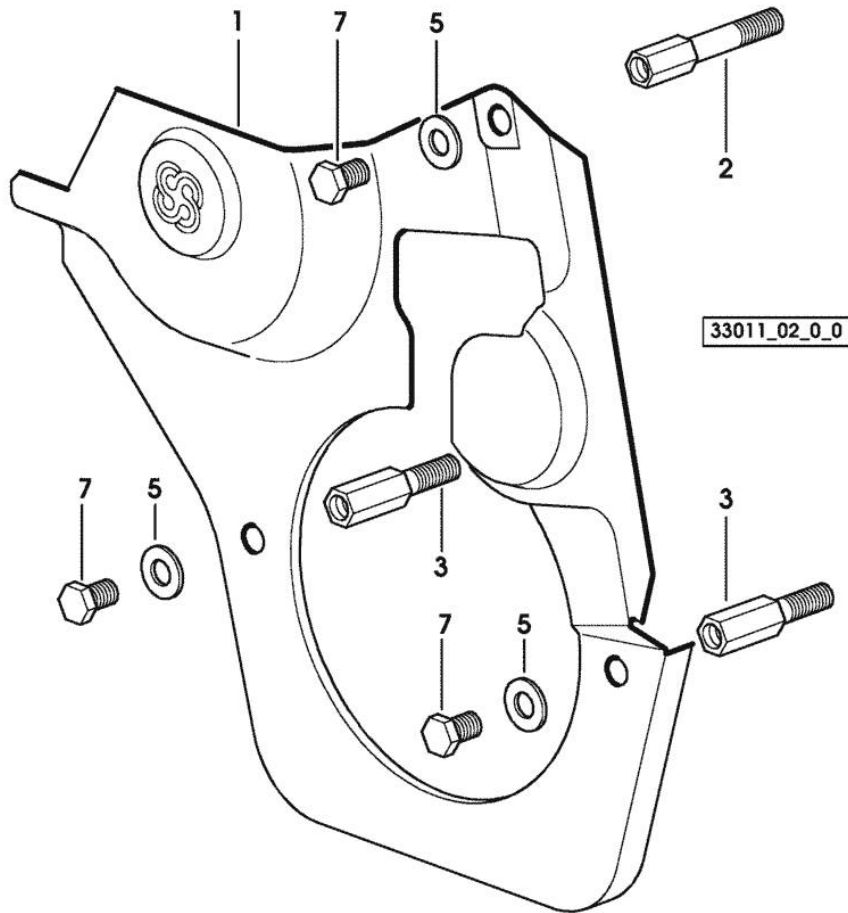

Section: ENGINE  
TIMING CASE

Fig.	P/n	QTY	Name
------	-----	-----	------

Notes:  
[XT-910.6]

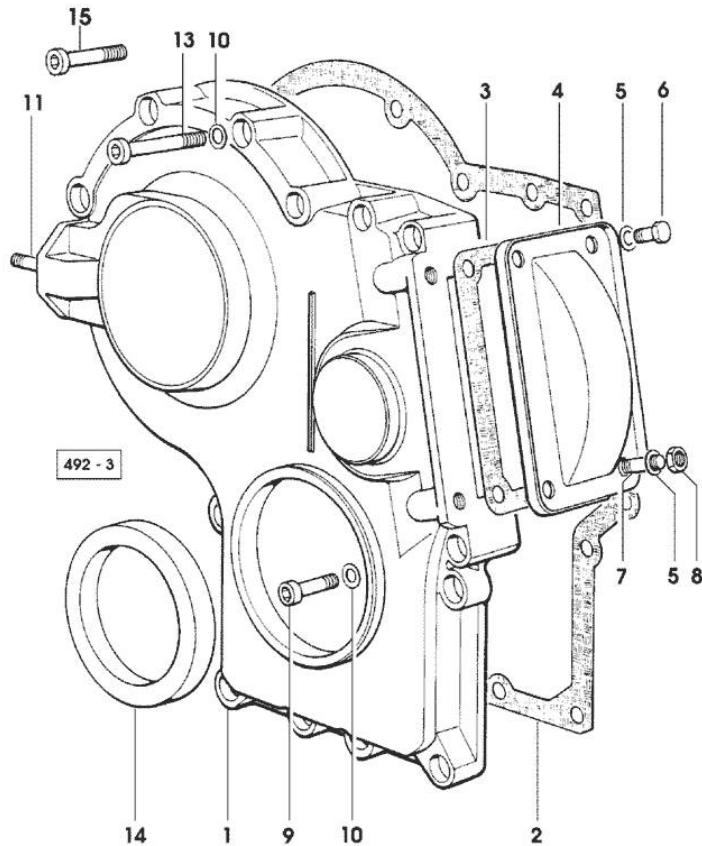

1	0.065.1132.0/60	1	guard
2	0.065.1150.0/30	1	gasket
3	0.065.1152.0	1	gasket
4	0.065.1151.0	1	cover
5	2.1470.004.2	4	lock washer 8
6	2.0112.205.2	2	screw m 8 p.1.25 x 16
7	2.0432.005.7	2	stud bolt m 8 p.1.5 / p.1 x 25
8	2.1011.405.2	2	nut m 8 p.1
9	2.0312.208.2	8	screw m 8 p.1.25 x 25
10	2.1480.014.1	15	washer 8
11	2.0432.003.7	2	stud bolt m 8 p.1.25 / p.1 x 20
13	2.0312.214.2	7	screw m 8 p.1.25 x 40 - x XT-908 XT-909 XT-910.4
14	2.1529.141.0	1	special oil seal
15	2.0312.219.2	4	screw m 8 p.1.25x65 - x XT-910.6

Section: ENGINE

**CRANKSHAFT**

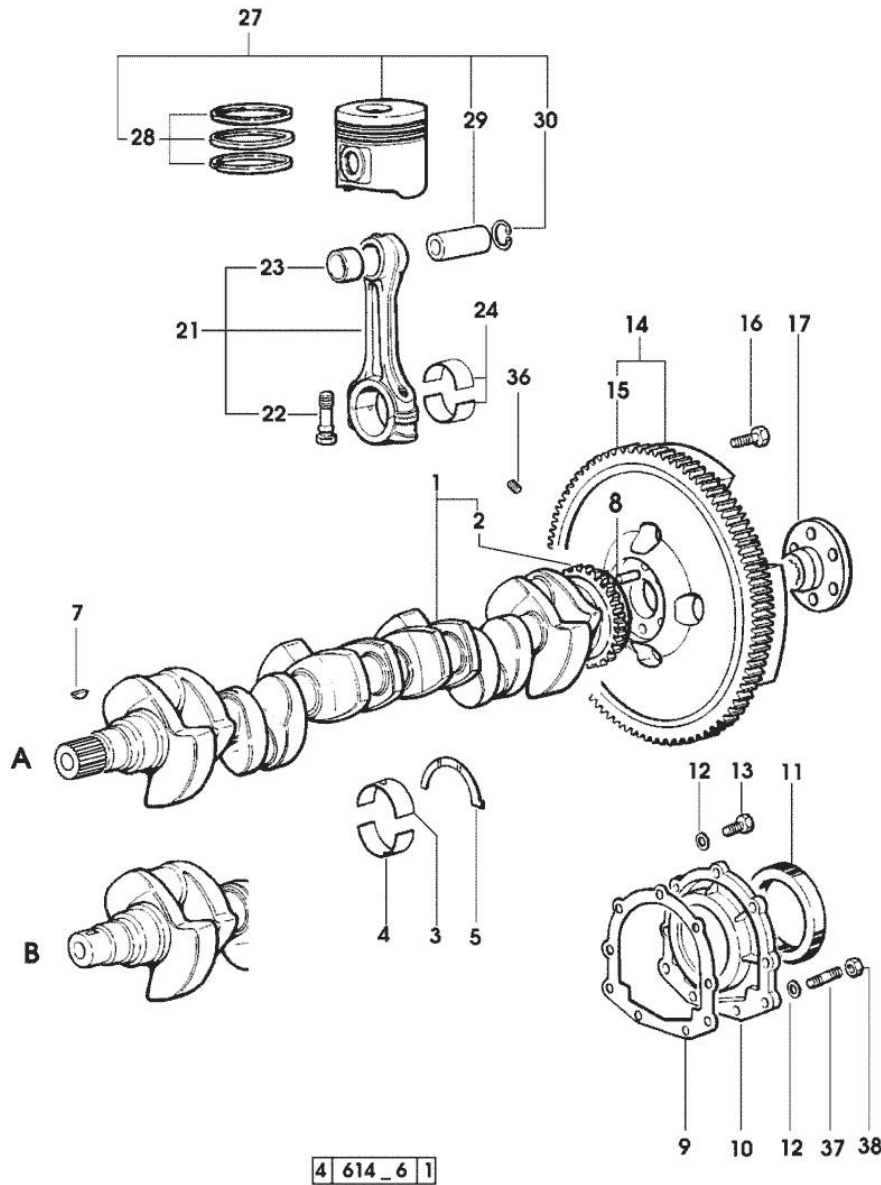

4 614\_6 1

Fig.	P/n	QTY	Name
<b>Notes:</b>			
[XT-910.6]			
1	0.010.4320.3/20	1	crankshaft (...) <- = " B " * N.1 011.2206.0/10
2	0.007.0855.0	1	gear
3	0.065.1215.0	7	main half bushing STANDARD
3	0.065.1215.7		main half bushing - mm 0.25
3	0.065.1215.8		main half bushing - mm 0.50
4	0.065.1216.0	7	main half bushing
4	0.065.1216.7		main half bushing - mm 0.25
4	0.065.1216.8		main half bushing - mm 0.50
5	0.065.1218.0	4	shim STANDARD
5	0.065.1218.7		shim + mm 0.10
5	0.065.1218.8		shim + mm 0.15
7	2.1720.006.0	1	key 4x6.5
8	2.1652.915.0	1	cylindrical plug 12x35
9	0.065.1254.0/20	1	gasket
10	0.007.0851.0/10	1	cover
11	2.1529.073.0	1	special oil seal 110x130x13
12	2.1474.009.2	9	spring washer 8
13	2.0112.207.2	7	screw m 8 p 1.25 x 20
14	0.007.1702.3/30	1	flywheel -> 1390
14	0.008.4049.3	1	flywheel mm 373 1389 <-
14	0.010.5467.3/10	1	flywheel 1392 <- X FASTDRIVE
14	0.010.8727.3	1	flywheel -> 1393 X FASTDRIVE
15	0.065.1242.0	1	crown wheel Z = 123
16	2.0119.174.0/10	6	screw m 12 p.1.25x45 - X FASTDRIVE
16	2.0139.022.2	6	screw m 12 p.1.25x55
17	0.008.5543.0	1	flange
21	0.078.1220.3/30	6	engine connecting rod
22	2.0399.213.0	12	screw m 12 p.1.25x61.5
23	2.1559.114.0/10	6	special bushing
24	0.065.1225.0	12	con.rod half bushing STANDARD - A = 28.75 -> 29.00
24	0.065.1225.7		con.rod half bushing - mm 0.25
24	0.065.1225.8		con.rod half bushing - mm 0.50
27	0.086.0060.6/30	6	complete piston
27	0.379.0060.6	6	complete piston

**CRANKSHAFT**

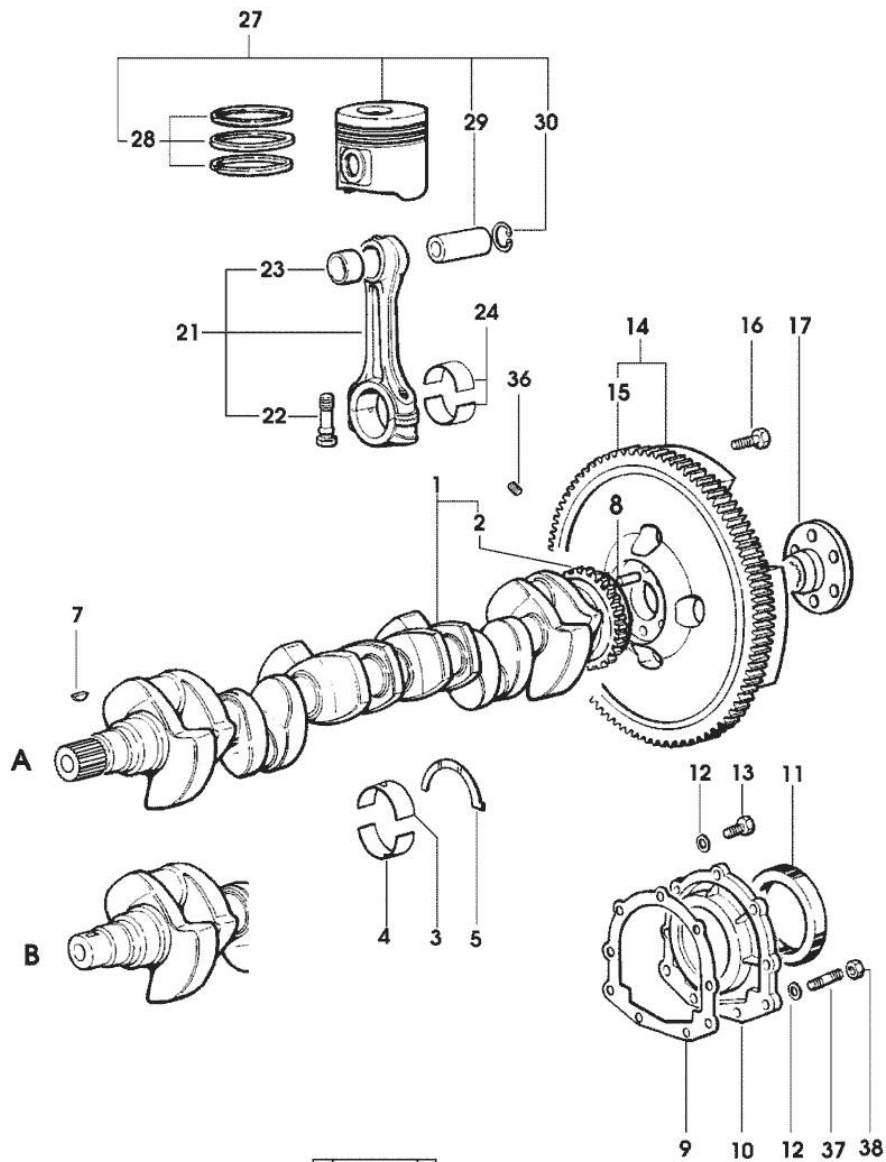

4 614\_6 1

Fig.	P/n	QTY	Name
			- EXPORT U.S.A.
28	0.086.0052.6/10	6	piston ring set
29	0.078.1236.0	6	piston pin Ø 18 / Ø 35 / L = mm 86
30	2.1411.014.1	12	circlip 35
36	2.3130.001.1	6	plug 1/8" gas
37	2.0432.003.7	2	stud bolt m 8 p.1.25 / p.1 x 20
38	2.1011.105.2	2	nut m 8 p.1.25

**ENGINE SHAFT - PULLEYS**

4 | 729\_6 | 2

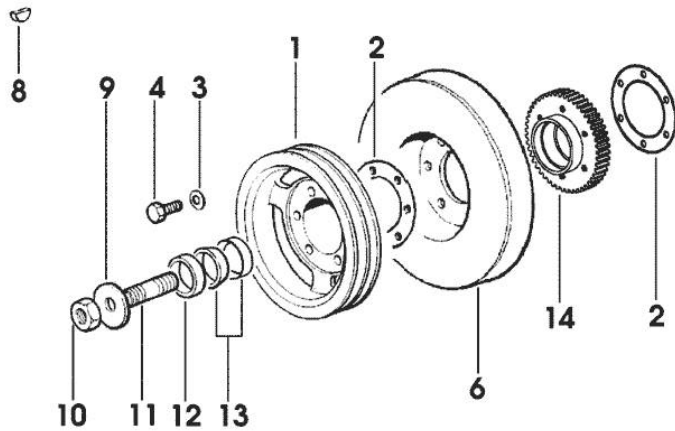
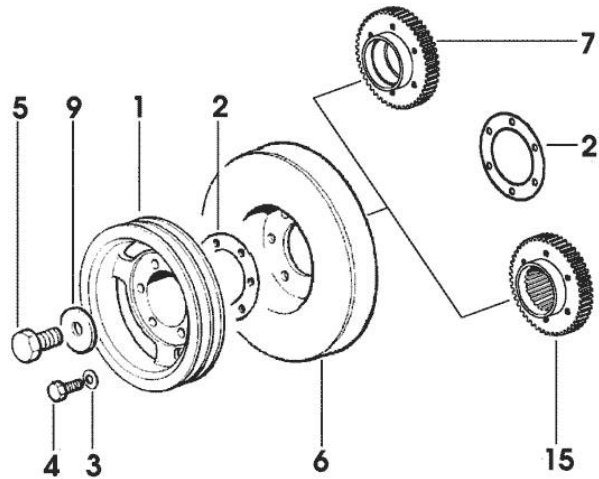
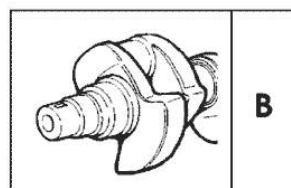
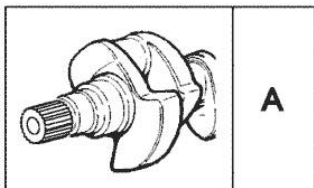

Fig.	P/n	QTY	Name
------	-----	-----	------

Notes:  
[XT-910.6]

1	0.007.0962.0/20	1	pulley
2	2.1589.137.0	1	shoulder ring 71x110x1
3	2.1470.006.2	6	lock washer 10
4	2.0112.322.2	6	screw m 10 p.1.5x65
5	2.0399.144.7/10	1	screw m 20 p.1.5x51
6	0.007.1010.3	1	antivibration pulley
7	0.011.2140.0/10	1	hub
			- X B (...) <=
8	2.1720.006.0	1	key 4x6.5
			- X B (...) <=
9	2.1599.524.7	1	washer 21x60x12
10	2.1019.094.7	1	nut m 20 p.1.5
			- X B (...) <=
11	2.0439.195.7	1	stud bolt m 20 p.1.5x80
			- X B (...) <=
12	2.1579.949.0	1	ring 50.2x56.8x8
			- X B (...) <=
13	0.035.1263.0	2	ring
			- X B (...) <=
14	0.011.2141.0/10	1	hub
			- FOR MODELS EQUIPPED WITH FRONT P.T.O.
			- X B (...) <=
15	0.011.2206.0/10	1	hub
			- X A => (...)



Section: ENGINE

**CAMSHAFT**

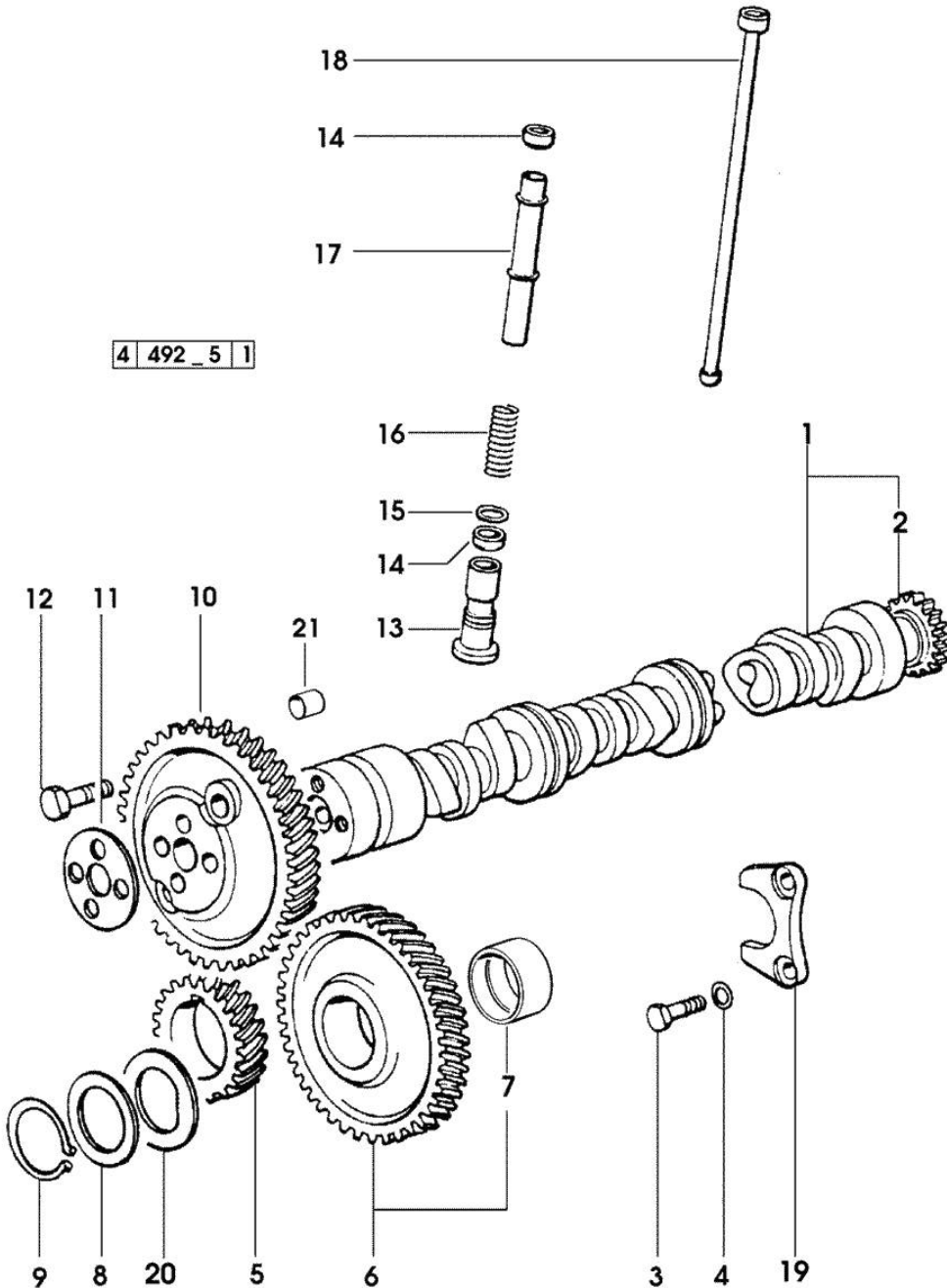

Fig.	P/n	QTY	Name
------	-----	-----	------

Notes:  
[XT-910.6]

1	0.010.4968.3/10	1	camshaft - EXPORT U.S.A.
1	0.075.1310.3/30	1	camshaft
2	0.065.1324.0/10	1	gear Z = 32
3	2.0312.206.2	2	screw m 8 p 1.25 x 20
4	2.1480.014.1	2	washer 8
5	0.007.1188.0/20	1	gear Z = 29
6	0.007.1177.3/10	1	gear z = 57 - WITH RED IDENTIFICATION STAMP
6	0.007.1178.3/10		gear z = 57 - WITH YELLOW IDENTIFICATION STAMP
6	0.007.1179.3/10		gear z = 57 - WITH GREEN IDENTIFICATION STAMP
7	2.1559.185.0/10	1	bushing
8	0.065.1352.0	1	shim
9	2.1410.016.1	1	circlip 40
10	0.065.1354.0/20	1	gear z=58
11	0.065.1350.0	1	small disc
12	2.0132.207.2	4	screw m 10 p.1 x 25
13	0.065.1330.0	12	tappets
14	2.1569.114.0/10	24	gasket 14x18.5x8
15	2.1599.437.0	12	shoulder ring
16	2.4019.300.1/10	12	spring 18.5x52x2
17	0.065.1332.0	12	sleeve
18	0.065.1331.2	12	rod
19	0.065.1353.0	1	small plate
20	0.065.1351.0	2	shoulder ring
21	2.1559.398.0	1	bushing 10.5x13x12



Section: ENGINE  
CYLINDER HEAD

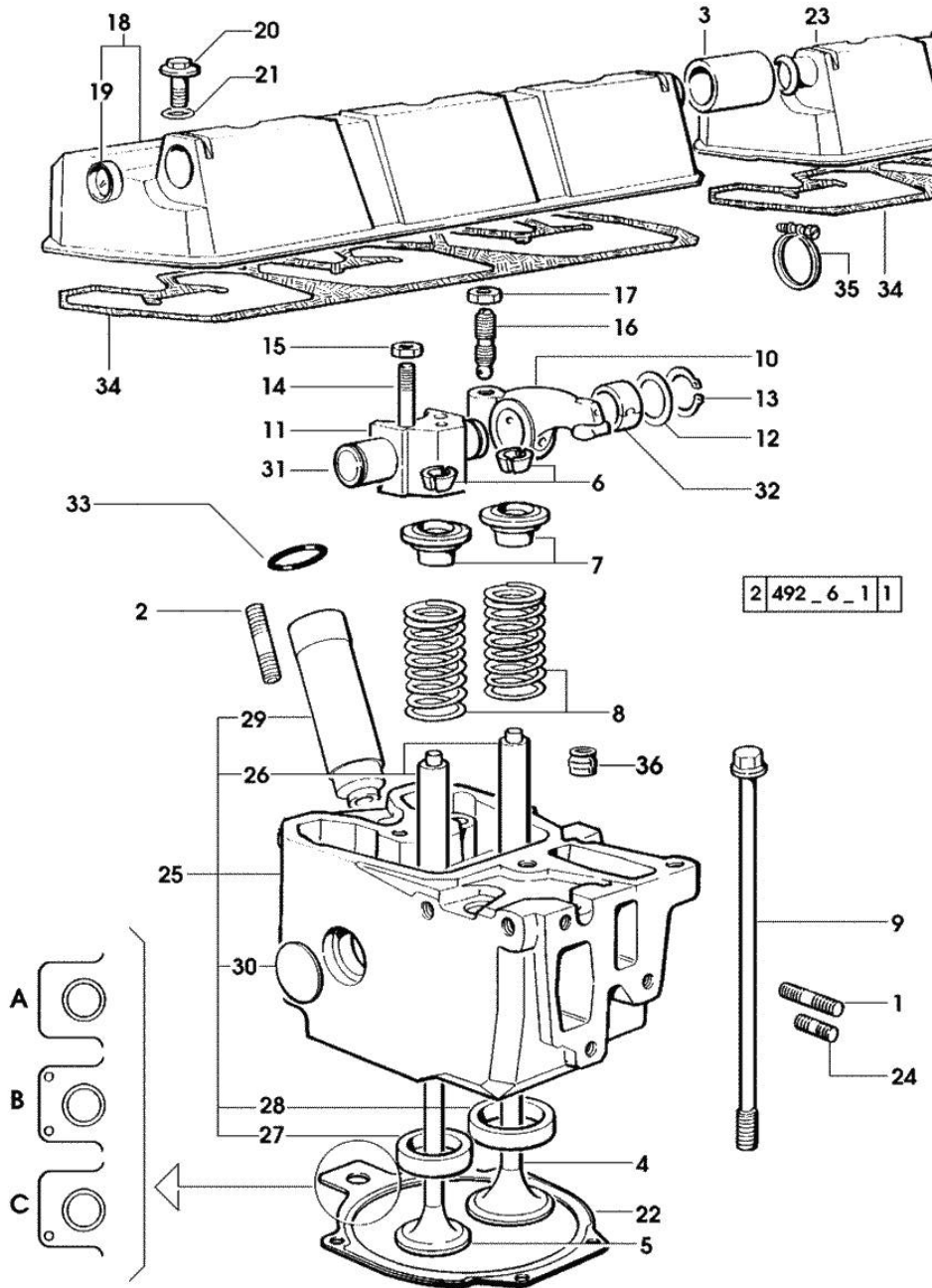

Fig.	P/n	QTY	Name
------	-----	-----	------

Notes:  
[XT-910.6]

1	2.0432.011.7	6	stud bolt m 8 p.1.25 / p.1 x 40
2	2.0432.161.7	6	stud bolt m 10 p.1.5 / p.1.25 x 40
3	0.075.1452.0/10	1	sleeve
4	0.010.6016.0	6	inlet valve mm 43.63 / Ø mm 9
5	0.066.1421.0	6	exhaust valve
6	0.074.1423.0	24	conical valve cotter
7	0.066.1425.0	12	cup
8	2.4019.287.0	12	spring
9	0.012.2673.0	24	screw m 14 p.2x141 => 3727 x XT-910.6
9	0.066.1443.0/10	24	screw 3726 <= x XT-910.6
10	0.066.1432.0	6	rocker arm
11	0.066.1430.0/10	6	support
12	2.1599.432.0	12	shoulder ring
13	2.1410.055.1	12	circlip 19
14	2.0432.163.7	6	stud bolt m 10 p.1.5 / p.1.25 x 45
15	2.1011.421.2	12	nut m 10 p.1.25
16	0.021.1434.0	12	screw
17	2.1011.405.2	12	nut m 8 p.1
18	0.078.1440.3	1	cover
19	2.3171.008.4	1	plug 20
20	2.0399.130.2/10	6	screw m 8x36x44
21	2.1532.035.0	6	oil seal 14x1.78
22	0.078.1451.0/40	6	head gasket -A-
22	0.078.1452.0/30	6	head gasket -B-
22	0.078.1453.0/40	6	head gasket -C-
23	0.078.1450.3	1	cover
24	2.0432.005.7	6	stud bolt m 8 p.1.5 / p.1 x 25
25	0.012.2693.3/10	6	engine head
26	0.007.1779.0/10	12	valve guide
27	0.066.1427.0	6	valve seat
28	0.078.1426.0	6	valve seat
29	0.010.6041.0	6	bush
30	2.3170.012.1	12	expansion plug 30
31	0.066.1431.0	6	pin
32	2.1559.021.0/40	1	bushing 15x19x22
33	2.1530.051.0	6	oil seal 20.22x3.53
34	0.069.1450.0/30	2	tappet gasket
35	2.6859.052.2	2	clamp
36	2.1519.117.0	12	special oil seal

Section: ENGINE  
LUBRICATION

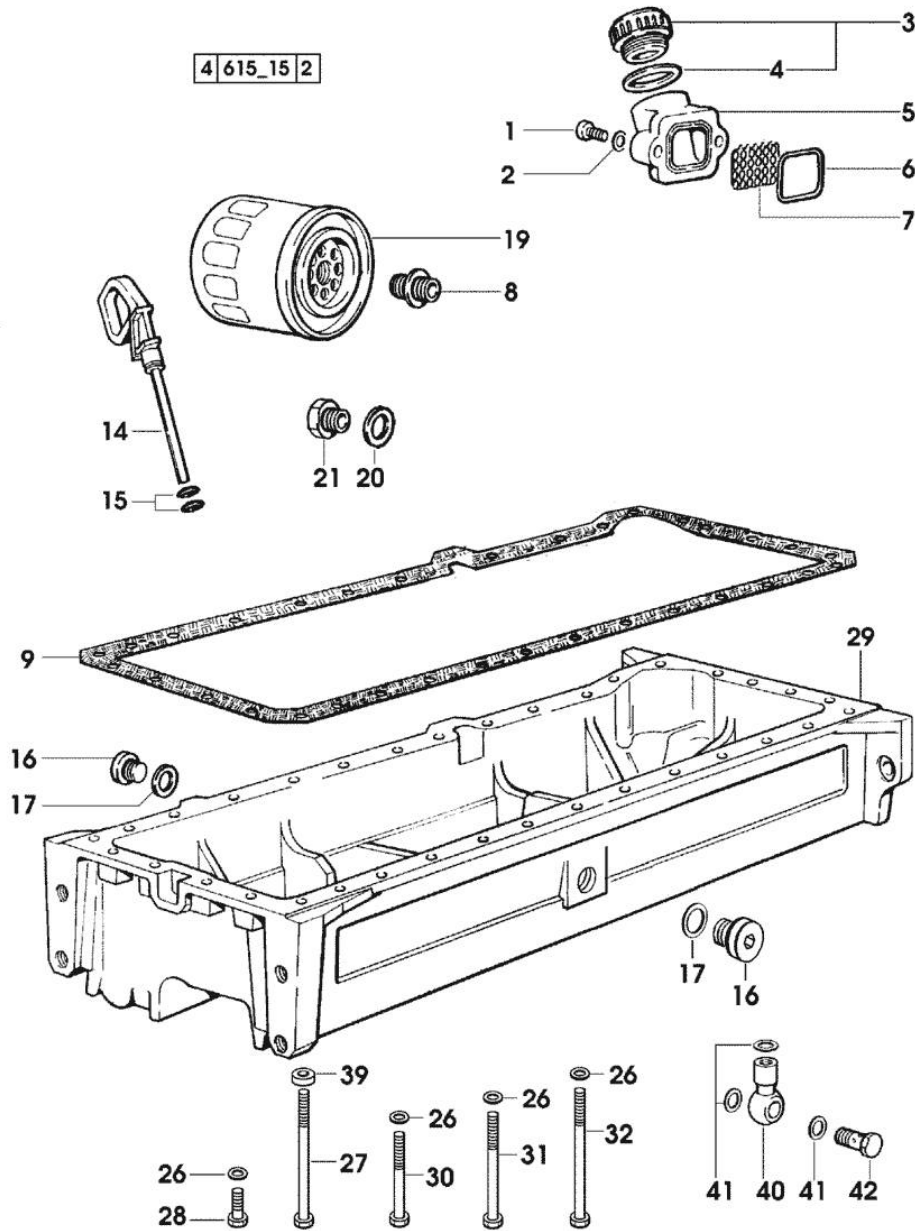

Fig.	P/n	QTY	Name
------	-----	-----	------

Notes:  
[XT-910.6]

1	2.0312.206.2	2	screw m 8 p 1.25 x 20
2	2.1480.014.1	2	washer 8
3	0.041.1135.4	1	plug 1" gas
4	2.1569.072.0	1	gasket 32 x 39.5 x 2
5	0.065.1565.0/10	1	pipe union
6	2.1539.042.0	1	special oil seal 47.35x1.78
7	0.065.1567.0/10	1	filter
8	2.3339.307.0	2	pipe fitting m 22 p.1.5-3/4"
9	0.007.0849.0/10	1	gasket
14	0.080.1513.2/10	1	dipstick
15	2.1539.065.0	2	special oil seal 8.73 x 1.78
16	2.3199.001.2	2	plug 1/2" gas
17	2.1560.054.0	2	gasket 21 x 26
19	0.044.1567.0	2	oil filter element
20	2.1560.014.0	1	washer 18.2 x 24
21	2.3339.353.2/20	1	pipe fitting 12 p.1.5-18 p.1.5
26	2.1470.004.2	34	lock washer 8
27	2.0112.243.2	2	screw m 8 p.1.25x170
28	2.0112.215.2	25	screw m 8 p.1.25 x 40
29	0.007.1311.0/10	1	oil sump
30	2.0112.229.2	3	screw m 8 p.1.25 x 100
31	2.0112.235.2	2	screw m 8 p.1.25 x 130
32	2.0112.241.2	4	screw m 8 p.1.25 x 160
39	2.1579.854.2	2	spacer 8.5x20x5
40	2.3249.014.2	1	pipe fitting m 12 p.1.5
41	2.1560.008.0	3	gasket 12.2 x 18
42	2.3335.052.2	1	pipe union m 12 p.1.5

Section: ENGINE  
LUBRICATION

Fig.	P/n	QTY	Name
------	-----	-----	------

Notes:  
[XT-910.6]

1	0.007.0703.0/10	1	box
2	0.007.1239.3	1	radiator
3	2.1560.014.0	1	washer 18.2 x 24
4	2.3120.101.0	1	plug m 18 p.1.5
5	0.078.1557.0/10	2	gasket
6	0.078.1556.0/10	1	gasket
7	0.078.1555.0/10	1	plate
8	2.1310.004.2	8	flat washer 8.4x17
9	2.0112.205.2	8	screw m 8 p.1.25 x 16
10	2.1480.014.1	4	washer 8
11	2.0312.220.1	2	screw m 8 p.1.25x70
12	2.0312.222.2	2	screw m 8 p.1.25 x 80
13	2.1539.048.0	1	special oil seal 20.35x1.78
14	2.1539.050.0	1	special oil seal 69.57x1.78
15	2.3249.023.1	2	pipe fitting m 24 p.2
16	2.3350.008.1	2	nosepiece 18

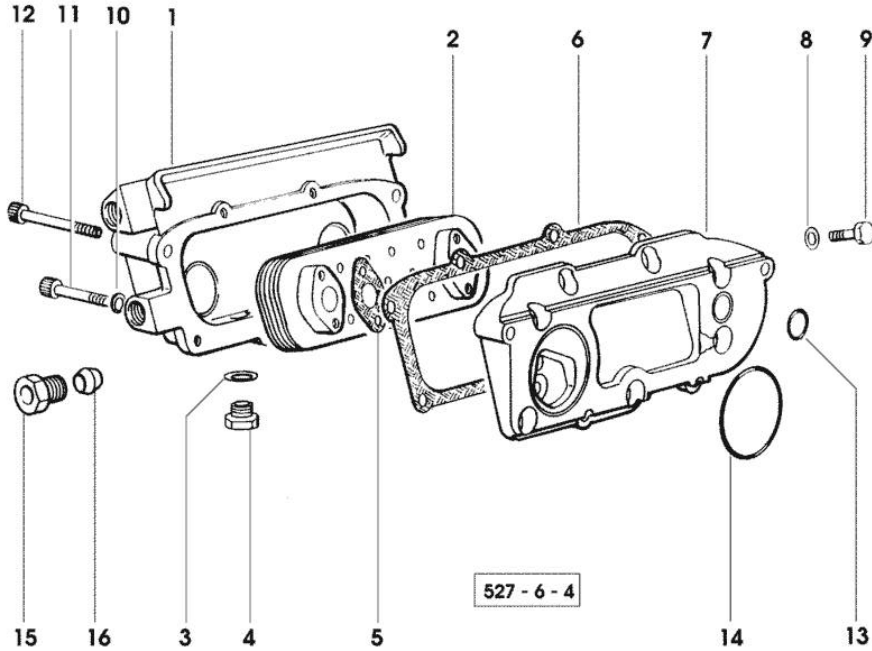

Section: ENGINE  
**LUBRICATION**

Fig.	P/n	QTY	Name
------	-----	-----	------

Notes:  
 [XT-910.6]

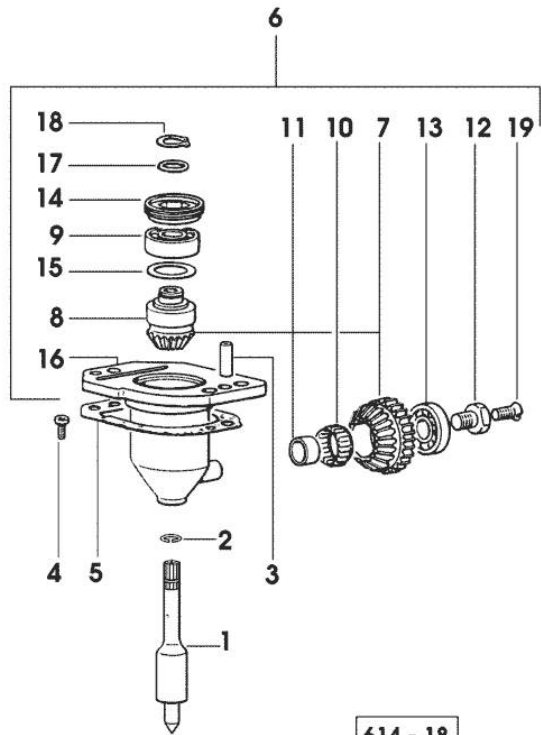

614 - 18

1	0.007.1036.0	1	shaft
2	2.1420.003.0	1	circlip a 10
3	2.1651.711.0	1	pin 8 x 14
4	2.0169.005.2	2	screw m 6 p.1 x 12
5	0.065.1560.0/20	1	gasket
6	0.075.1551.4/20	1	support
7	0.065.1558.6/10	1	bevel drive
8	0.065.1559.0	1	bush
9	2.2020.001.0	1	ball bearing 15 x 32 x 8.00
10	2.2725.016.0	1	roller cage 15 x 21 x 12
11	2.2680.020.0	1	ring 12 x 15 x 12
12	2.0399.128.2/10	1	screw m 8 p.1 x 8
13	2.2030.002.0	1	ball bearing 12 x 28 x 8
14	2.1219.025.2/10	1	ring nut m 36 p.1.5
15	2.1589.148.0	1	shoulder ring 28.2 x 31.8 x 0.5
15	2.1589.150.0	2	shoulder ring 28.2 x 31.8 x 0.1
15	2.1589.151.0	2	shoulder ring 28.2 x 31.8 x 0.15
16	0.075.1551.3/30	1	support
17	2.1589.146.0	2	shoulder ring 15.2 x 19 x 0.15
17	2.1589.147.0	2	shoulder ring 15.2 x 19 x 0.10
17	2.1589.153.0	1	shoulder ring 15.2 x 19 x 1.00
18	2.1410.057.1	1	circlip 15
19	2.0342.007.2	1	screw m 4 p.0.7x25

Section: ENGINE  
LUBRICATION

Fig.	P/n	QTY	Name
------	-----	-----	------

Notes:  
[XT-910.6]

1	0.007.1312.3	1	tube (...) <-
2	2.1470.004.2	2	lock washer 8
3	2.1470.004.2	1	lock washer 8
4	2.0112.205.2	1	screw m 8 p.1.25 x 16
5	0.007.0997.0	1	gasket (...) <-
6	2.0112.207.2	2	screw m 8 p 1.25 x 20
7	2.1539.153.0	1	oil seal 32.99x2.6 -> (...)
8	2.0112.322.2	3	screw m 10 p.1.5x65
9	2.1310.006.2	3	flat washer 10.5x21
10	0.007.0972.0	2	shim
11	0.007.0973.0	2	shim
12	0.007.0867.0	1	bush
13	0.000.0000.1		cannot be supplied * (...) <- - N.1 - 010.0194.4/30 - 011.0087.4 - 2.1539.153.0
14	0.007.1371.0	1	piston
15	0.007.1373.0	1	spring
16	0.007.1372.0	1	cup
17	0.007.1438.0/10	1	gear
18	0.007.1437.0	1	washer
19	0.007.1436.0	1	circlip
20	0.000.0000.1		cannot be supplied
21	0.011.0087.4	1	tube -> (...)
22	0.010.0194.4/30	1	oil pump -> (...) ☞ 0.010.0194.4/30 ☞ 01.00.63

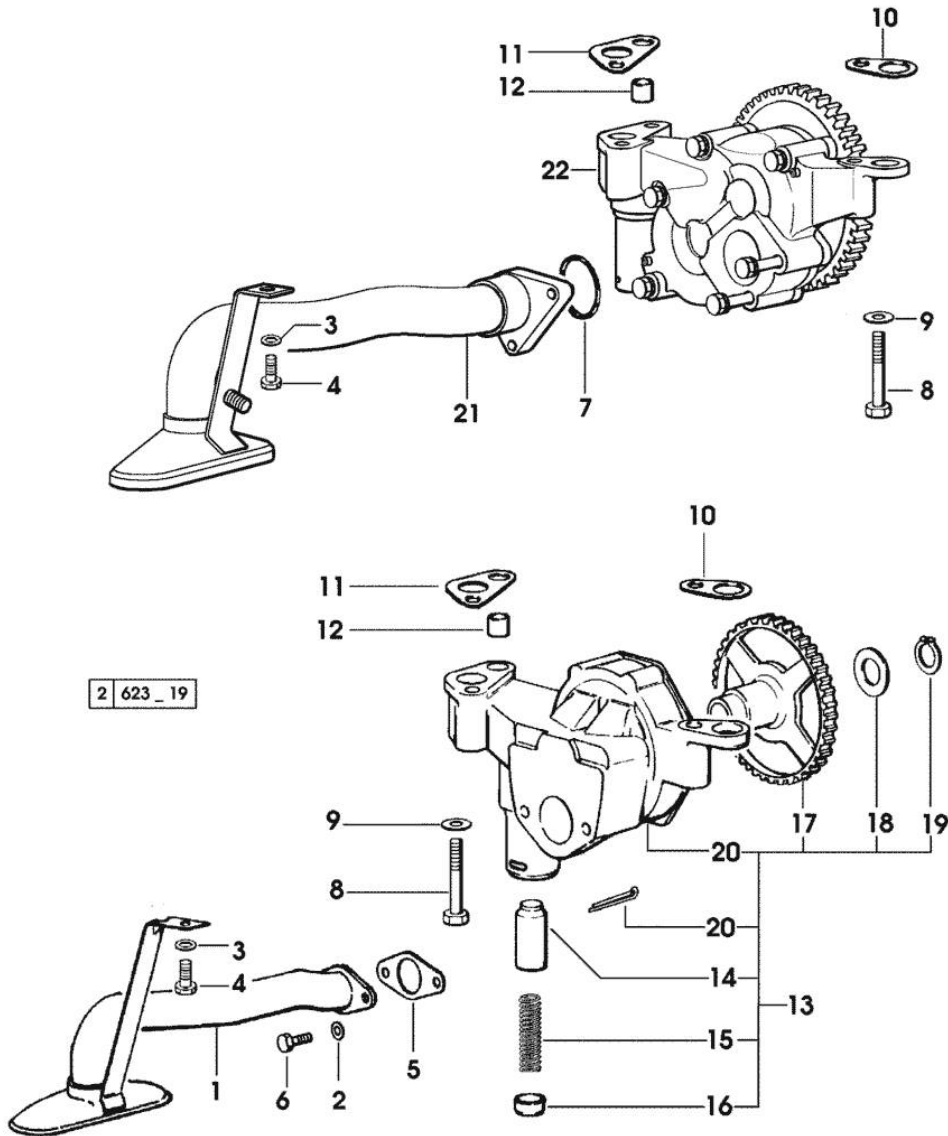

Section: ENGINE

**OIL PUMP**

Fig.	P/n	QTY	Name
------	-----	-----	------

Notes:  
[XT-910.6]

1	0.010.0194.4/30	1	oil pump ☞ 0.010.0194.4/30
2	0.007.0866.3/10	1	valve
3	0.010.1709.0	1	gear z=8
4	2.0112.220.2	2	screw m 8 p.1.25x55
5	2.1475.002.7	6	washer 8.4
6	2.0112.219.2	2	screw m 8 p.1.25x55
7	0.010.0195.3/20	1	cover
8	2.1410.064.7	1	circlip
9	0.010.1708.0/20	1	gear z=8
10	2.1651.204.0	1	pin 3x10
11	0.000.0000.1		cannot be supplied
12	0.000.0000.1		cannot be supplied
13	2.1560.020.0	1	copper gasket 24.3x32
14	2.0112.217.2	2	screw m 8 p.1.25 x 45
15	2.1630.608.0	2	pin 6x16
16	0.000.0000.1		cannot be supplied

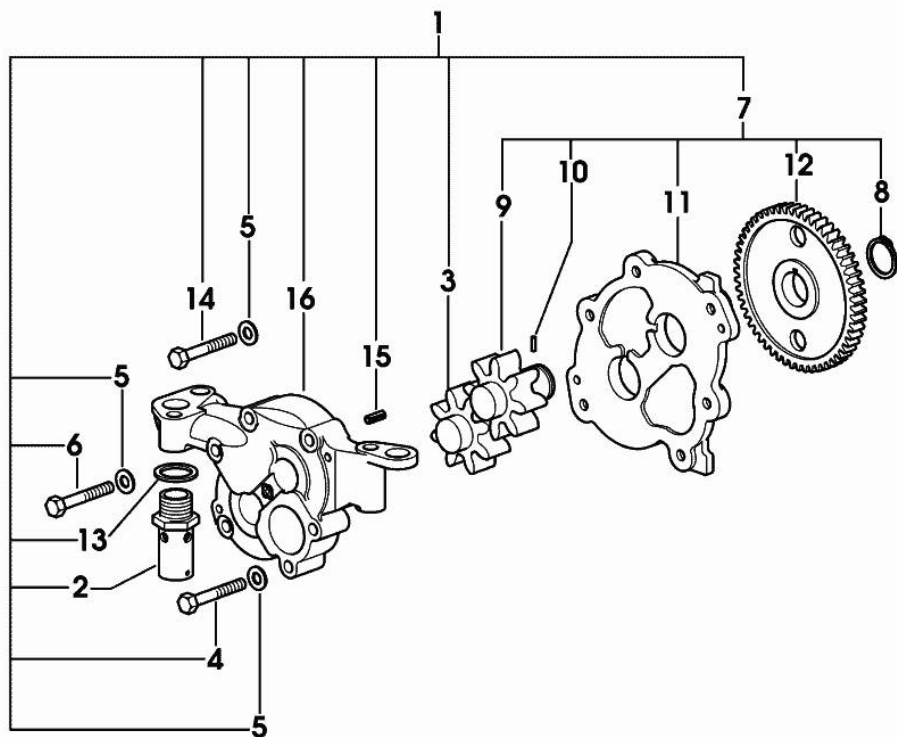

0\_010\_0194\_4\_30

Section: ENGINE  
**LUBRICATION**

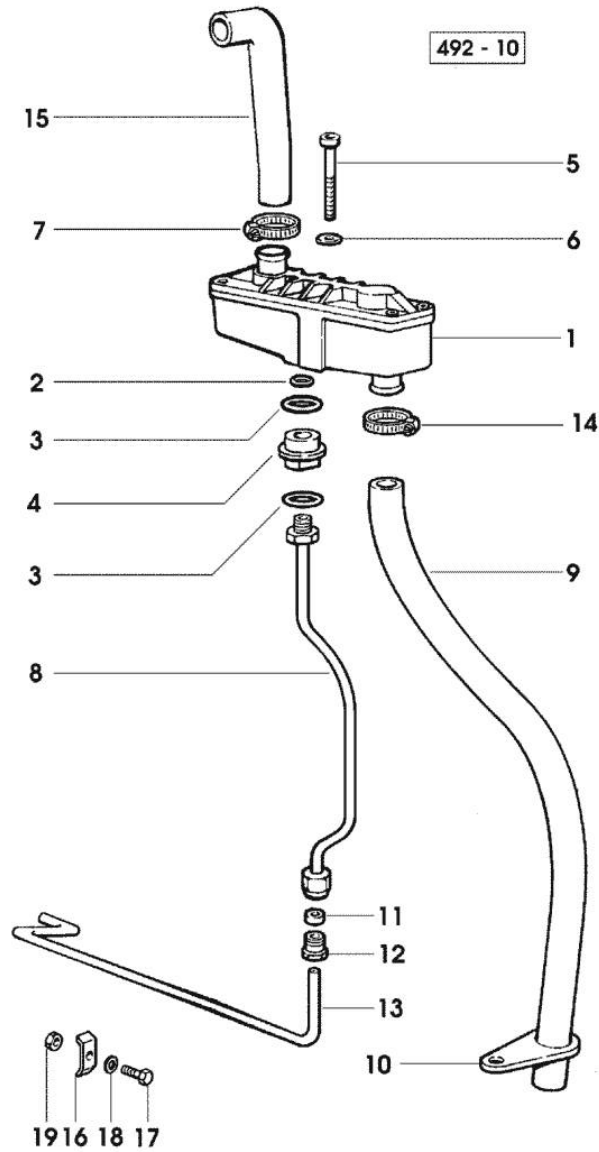

Fig.	P/n	QTY	Name
<b>Notes:</b>			
[XT-910.6]			
1	0.075.1557.4	1	sediment bowl
2	2.1560.008.0	1	gasket 12.2 x 18
3	2.1539.072.0	2	special oil seal 23.52 x 1.78
4	0.075.1553.0	1	bush
5	2.0312.221.2	2	screw m 8 p.1.25x75
6	2.1480.014.1	2	washer 8
7	2.6859.086.0	2	clamp
8	0.007.0861.0	1	tube
9	0.075.1554.0	1	tube
10	0.075.1151.0	1	bracket
11	2.3350.003.1	1	nosepiece 8
12	2.3339.418.1	1	pipe fitting m 12 p.1
13	0.007.0970.0	1	tube
14	2.6859.086.0	1	clamp
15	0.075.1453.0/10	1	tube
16	0.002.8816.0	1	small plate
17	2.0112.007.2	1	screw m 6 p.1 x 20
18	2.1310.002.2	1	flat washer 6.4x12.5
19	2.1011.103.2	1	nut m 6 p.1

Thank you so much for reading.  
Please click the “Buy Now!”  
button below to download the  
complete manual.



After you pay.

You can download the most  
perfect and complete manual in  
the world immediately.

Our support email:

[ebooklibonline@outlook.com](mailto:ebooklibonline@outlook.com)