

Section: B0 - ENGINE

CRANKCASE

Fig.	P/n	QTY	Name
------	-----	-----	------

Notes:

[36 DI - LD 2WD]

2	2.1532.072.0	1	oil seal 26.70x1.78
3	2.3199.405.2	1	plug m 28 p.1.5
5	2.0432.003.7	6	stud bolt m 8 p.1.25 / p.1 x 20
6	2.1559.188.2	2	bush 11.4 x 14 x16
7	2.1539.259.0	4	special oil seal 107.62x2.62
8	2.1560.010.0	1	gasket 14.2 x 20
9	2.3199.292.0	1	plug 1/4" gas
10	0.012.9781.4/20	1	crankcase
10.1	2.3130.001.1	7	plug 1/8" gas
10.2	2.3130.002.1	2	plug 1/4" gas
10.3	2.3130.003.1	2	plug 3/8" gas
10.5	2.3179.012.0	1	plug 60
11	0.066.1152.0/10	4	gasket
26	2.3120.101.0	1	plug m 18 p.1.5
27	2.1560.014.0	1	washer 18.2 x 24
99.4.1	0.065.1112.3	1	support
99.4.2	0.065.1114.0/10	1	support
99.4.3	0.065.1116.3	1	support
99.4.3.2	2.1699.165.0	1	bush 12.3x15x16
99.4.5	0.012.0829.0	1	special bushing 59X55X20
99.4.6	0.012.0830.0	1	special bushing 59X55X30
99.4.7	0.014.1340.0/10	1	pin mm 85
99.4.8	0.065.1117.0	1	screw m 12 x 100

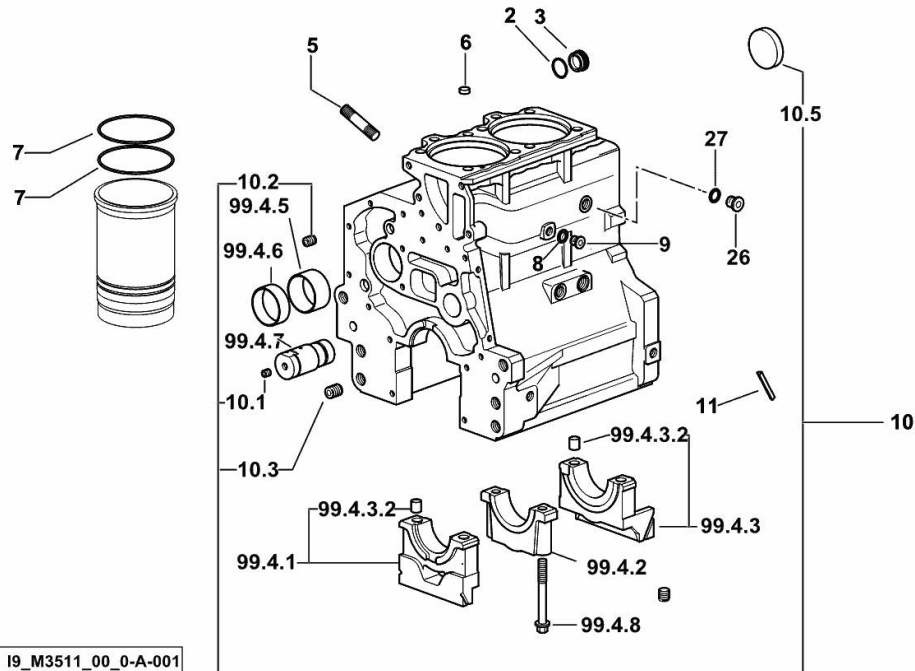

MONOBLOC ENGINE-GEARBOX CONNECTING FLANGE

Fig.	P/n	QTY	Name
------	-----	-----	------

Notes:

[36 DI - LD 2WD] -> 16849

1	0.015.8814.0	1	flange
2	2.0112.511.2	8	screw m 14 p.2 x 30
3	2.0432.255.7	2	stud bolt m 12 p.1.75-1.25x25
4	2.1651.912.0	4	cylindrical plug 12x28
5	2.0512.404.7	2	screw

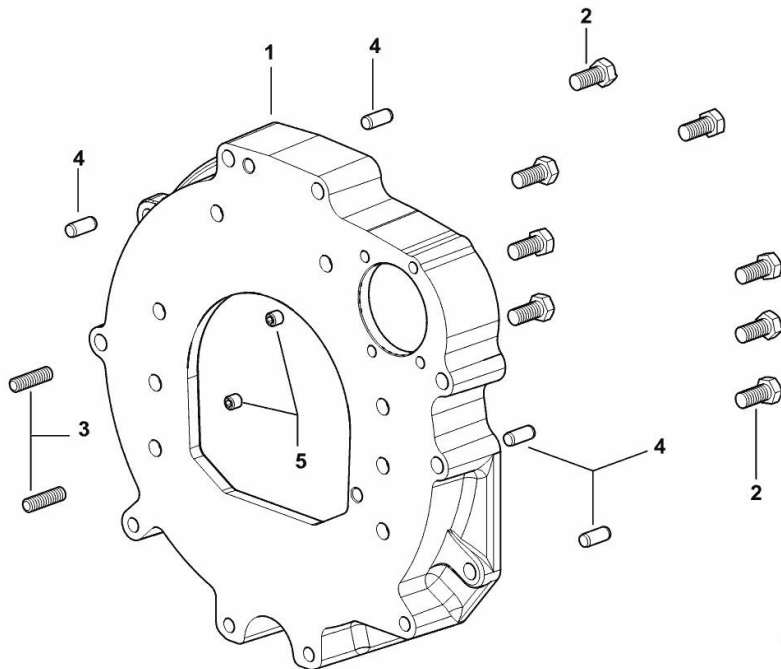

CRANKSHAFT

Fig.	P/n	QTY	Name
------	-----	-----	------

Notes:

[36 DI - LD 2WD]

4	2.3130.001.1	3	plug 1/8" gas
6	2.1720.006.0	2	key 4x6.5
7	0.012.9799.3/30	1	crankshaft
8	0.065.1215.0/10	3	main half bushing STANDARD
9	0.065.1216.0/10	3	main half bushing STANDARD
10	0.065.1218.0	4	shim STANDARD
15	0.065.1254.0/20	1	gasket
16	0.007.1711.0/10	1	cover
17	2.1475.002.2	9	conical washer 8
18	2.0112.207.2	9	screw m 8 p 1.25 x 20
19	2.1529.073.0	1	special oil seal 110x130x13
20	2.1652.915.0	1	cylindrical plug 12x35
801	0.065.1215.7	1	main half bushing - mm 0.25
802	0.065.1215.8	1	main half bushing - mm 0.50
901	0.065.1216.7	1	main half bushing - mm 0.25
902	0.065.1216.8	1	main half bushing - mm 0.50
1001	0.065.1218.7	1	shim + mm 0.10
1002	0.065.1218.8	1	shim + mm 0.15

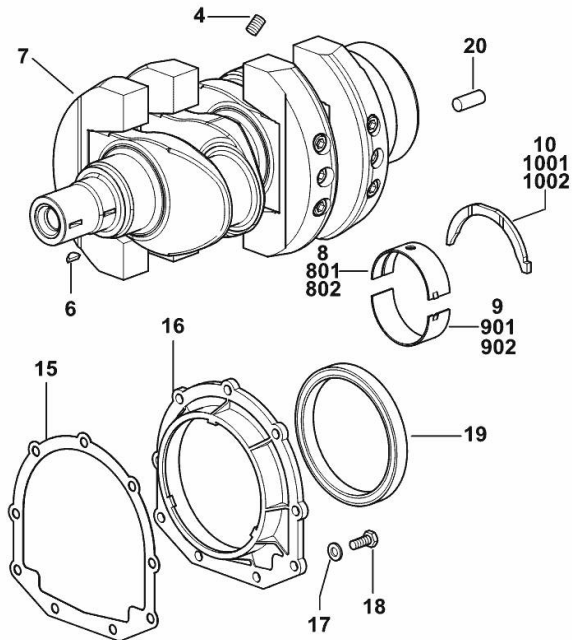

19_M3512_00_0-A-001

Section: B0 - ENGINE

CRANKSHAFT PULLEY

Fig.	P/n	QTY	Name
------	-----	-----	------

Notes:

[36 DI - LD 2WD]

1	2.1599.524.7	1	washer 21x60x12
3	0.007.1457.0/30	1	pulley (7659 <-)
3	0.014.5093.0	1	pulley (-> 8390)
5	0.085.1248.0/20	1	hub (-> 7652)
6	2.0399.144.7/10	1	screw m 20 p.1.5x51
8	2.1720.006.0	1	key 4x6.5

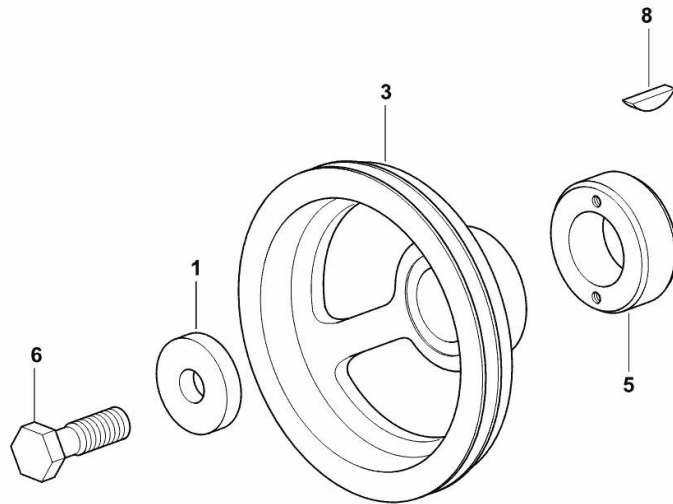

19_M3512_04_0-A-001

Section: B0 - ENGINE

ENGINE FLYWHEEL

Fig.	P/n	QTY	Name
------	-----	-----	------

Notes:

[36 DI - LD 2WD] 17759 <-

1	0.014.4175.3	1	flywheel (-> 7652)
1.2	0.069.1242.0	1	crown wheel Z = 121
2	2.0119.174.0/10	6	screw m 12 p.1.25x45
3	2.2041.008.9	1	ball bearing 20x47x14

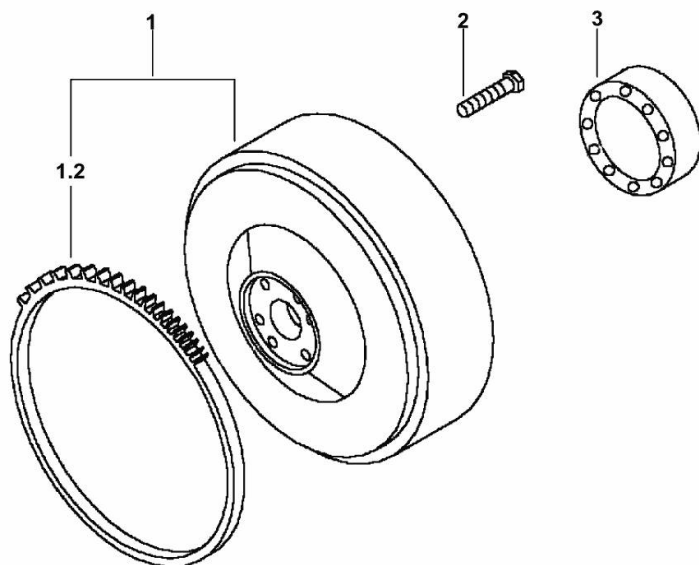

19_M3512_02_0-A-001

Section: B0 - ENGINE

ENGINE FLYWHEEL

Fig.	P/n	QTY	Name
------	-----	-----	------

Notes:

[36 DI - LD 2WD] -> 20271

1	0.017.8800.3	1	flywheel
1.2	0.069.1242.0	1	crown wheel Z = 121
2	2.0119.174.0/10	6	screw m 12 p.1.25x45
3	2.2041.008.9	1	ball bearing 20x47x14

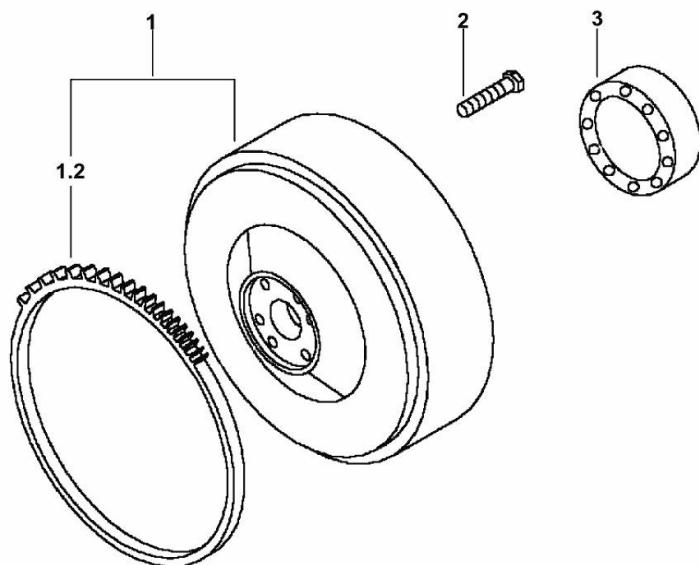

19_M3512_07_0-A-001

COOLANT PUMP DRIVEBELT

Fig.	P/n	QTY	Name
------	-----	-----	------

Notes:

[36 DI - LD 2WD]

31	2.4119.139.0	1	belt mm 10.7x1254 (20280 <-)
31	2.4119.198.0	1	vee belt AV 10.7x1240 mm (-> 20383)

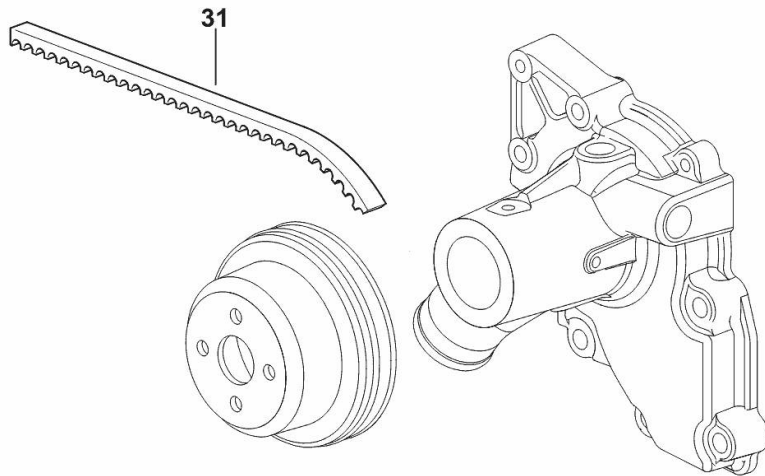

19_38519_11_0-B-001

CYLINDER - PISTON - CONNECTING ROD

Fig.	P/n	QTY	Name
------	-----	-----	------

Notes:

[36 DI - LD 2WD]

1	0.386.0065.A	3	cyl. piston assembly "A" - CLASS A
1	0.386.0065.B	3	cyl. piston assembly "B" - CLASS B
1.1	0.A12.2675.0	1	engine cylinder "A" - CLASS A
1.1	0.B12.2675.0	1	engine cylinder "B" - CLASS B
1.2	0.379.0060.A	1	complete piston "A" - CLASS A
1.2	0.379.0060.B	1	complete piston "B" - CLASS B
1.2.1	0.086.0052.6/10	1	piston ring set
1.2.2	2.1411.014.1	1	circlip 35
1.2.3	0.078.1236.0	1	piston pin Ø 18 / Ø 35 / L = mm 86
2	0.065.1225.0	6	con.rod half bushing STANDARD - A = 28.75 -> 29.00
2	0.065.1225.7	6	con.rod half bushing - mm 0.25
2	0.065.1225.8	6	con.rod half bushing - mm 0.50
3	0.078.1220.3/30	1	engine connecting rod
3.1	2.0399.213.0	2	screw m 12 p.1.25x61.5
3.2	2.1559.114.0/10	1	special bushing

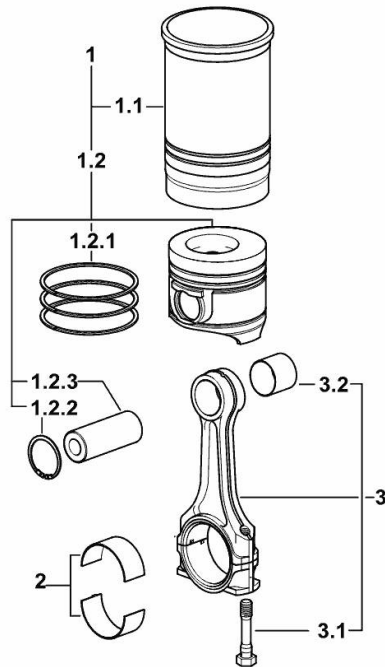

I9_M3512_01_M-A-001

CAMSHAFT

Fig.	P/n	QTY	Name
------	-----	-----	------

Notes:

[36 DI - LD 2WD]

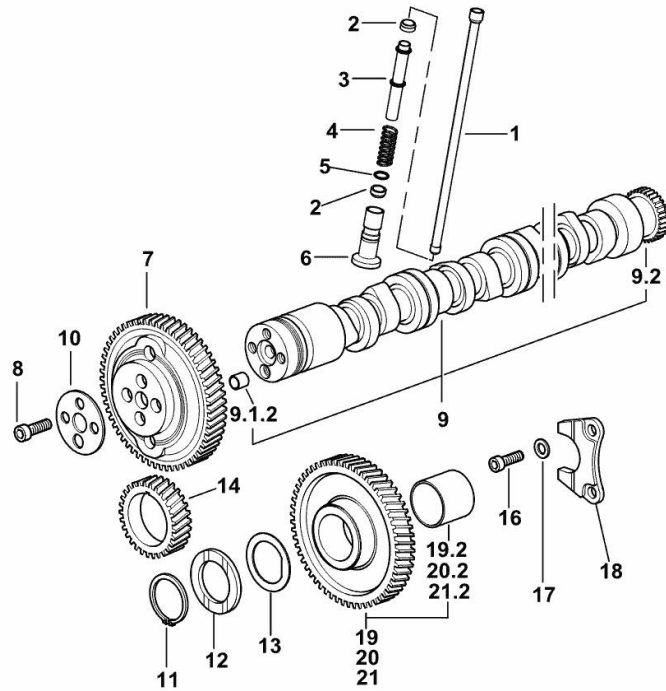

19_M3513_00_0-A-001

1	0.065.1331.2	4	rod
2	2.1569.114.0/10	8	gasket 14x18.5x8
3	0.065.1332.0	4	sleeve
4	2.4019.300.1/10	4	spring 18.5x52x2
5	2.1599.437.0	4	shoulder ring
6	0.065.1330.0	4	tappets
7	0.013.5017.0	1	gear z=58
8	2.0132.207.2	4	screw m 10 p.1 x 25
9	0.012.0701.4	1	none
9.1.2	2.1559.398.0	1	bushing 10.5x13x12
9.2	0.065.1324.0/10	1	gear Z = 32
10	0.065.1350.0	1	small disc
11	2.1410.016.1	1	circlip 40
12	0.065.1352.0	1	shim
13	0.018.2233.0	2	shoulder ring
14	0.065.1323.0/30	1	gear Z = 29
16	2.0312.205.2	2	screw
17	2.1480.014.1	2	washer 8
18	0.065.1353.0	1	small plate
19	0.007.1177.3/20	0.1	gear z = 57
19.2	2.1559.185.0/10	1	bushing
20	0.007.1178.3/20	0.1	gear z = 57
20.2	2.1559.185.0/10	1	bushing
21	0.007.1179.3/20	0.8	gear z = 57
21.2	2.1559.185.0/10	1	bushing

Section: B0 - ENGINE

TIMING CASE

Fig.	P/n	QTY	Name
------	-----	-----	------

Notes:

[36 DI - LD 2WD]

15	2.0432.003.7	2	stud bolt m 8 p.1.25 / p.1 x 20
16	2.0312.214.2	7	screw m 8 p.1.25 x 40
17	2.1480.014.1	15	washer 8
18	0.013.4981.0	1	guard
19	0.065.1150.0/30	1	gasket
20	2.1470.004.2	4	lock washer 8
21	2.1011.405.2	2	nut m 8 p.1
22	2.0312.208.2	8	screw m 8 p.1.25 x 25
23	2.1529.167.0	1	oil seal

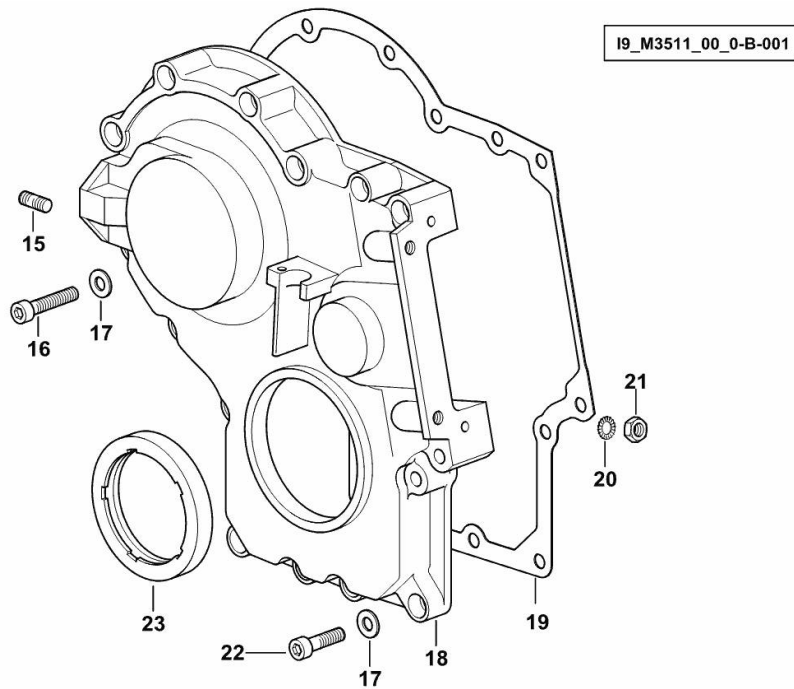

Section: B0 - ENGINE
CYLINDER HEAD

Fig.	P/n	QTY	Name
------	-----	-----	------

Notes:
 [36 DI - LD 2WD]

1	2.0399.130.2/10	2	screw m 8x36x44
2	2.1569.170.0/10	2	gasket 8.2 x 14
3	0.016.0291.0	2	small cap
4	0.012.9811.0	1	gasket
7	2.1011.421.2	4	nut m 10 p.1.25
9.1	0.066.1431.0	1	pin
9.2	0.021.1434.0	2	screw
9.10.3	2.1011.405.2	2	nut m 8 p.1
9.10.4	0.066.1432.3	2	rocker arm
9.10.4.2	2.1559.021.0/40	1	bushing 15x19x22
9.10.5	2.1410.055.7	2	circlip 19
9.10.6.2	0.066.1430.0/10	1	support
9.10.7	2.1599.432.0	2	shoulder ring
16	2.1530.051.0	2	oil seal 20.22x3.53
17	0.012.2673.0	8	screw m 14 p.2x141
18.1	0.014.8945.3/10	1	head
18.1.2	0.014.8942.0	1	valve seat mm 45.118
18.1.3	0.014.8941.0	1	valve seat mm 40.653
18.1.4	0.007.1779.0/20	2	valve guide
18.1.5	0.010.6041.0/10	1	bush
18.1.6	2.3170.012.2	2	expansion plug Ø 30
18.2	0.014.0120.0	1	exhaust valve mm 39.1 / Ø mm 9
18.3	0.014.0117.0	1	inlet valve mm 43.63 / Ø mm 9
18.4	0.066.1425.0	2	cup
18.5	0.074.1423.0	4	conical valve cotter
18.6	2.4019.287.0	2	spring
18.7	2.1519.117.0	2	special oil seal
18.8	2.0432.161.7	1	stud bolt m 10 p.1.5 / p.1.25 x 40
18.9	2.0432.163.7	2	stud bolt m 10 p.1.5 / p.1.25 x 45
20	2.0432.011.7	2	stud bolt m 8 p.1.25 / p.1 x 40
21	2.0432.005.7	2	stud bolt m 8 p.1.5 / p.1 x 25
24	0.014.5260.0	0.5	gasket (17759 <-)
24	0.014.5260.0/10	0.5	gasket - A - mm 1.4 (-> 20271)
25	0.014.5259.0	1	gasket (17759 <-)
25	0.014.5259.0/10	1	gasket - B - mm 1.2 (-> 20271)
26	0.014.5261.0	0.5	gasket (17759 <-)
26	0.014.5261.0/10	0.5	gasket - C - mm 1.6 (-> 20271)

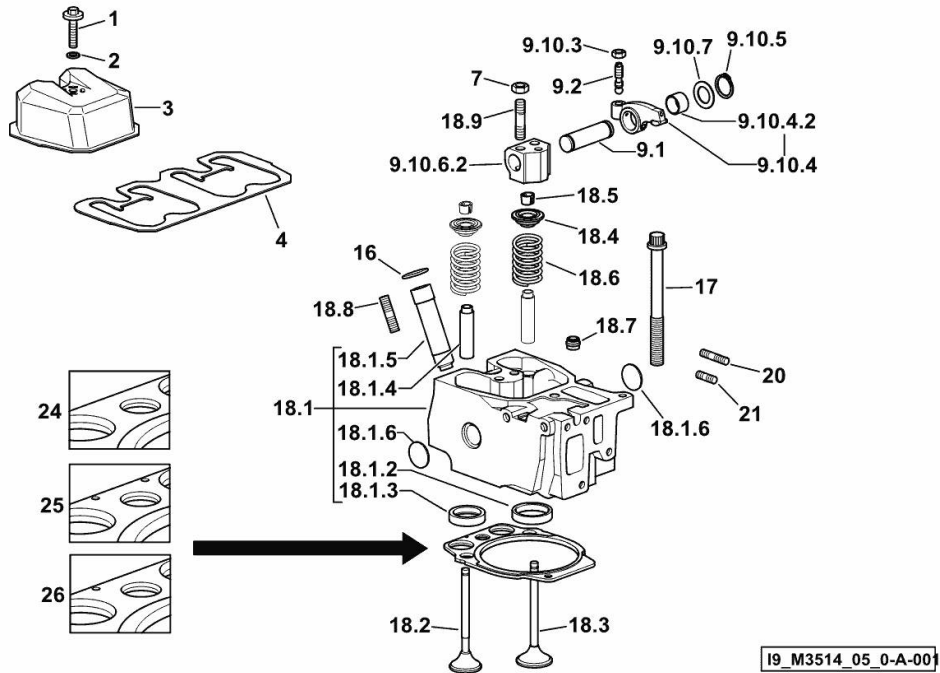

Section: B0 - ENGINE
ENGINE OIL PUMP

Fig.	P/n	QTY	Name
------	-----	-----	------

Notes:
 [36 DI - LD 2WD]

35	0.065.1560.0/30	2	gasket
36	2.0169.005.2	2	screw m 6 p.1 x 12
37	2.1652.711.0	2	cylindrical plug 8x25
38	0.075.1551.4/30	1	support
38.1	0.075.1551.3/40	1	support
38.1.2	2.1559.186.0	1	special bushing 26 x 31.5 x 35
38.2	2.1219.025.2/10	1	ring nut m 36 p.1.5
38.3	2.1410.057.1	1	circlip 15
38.4	2.1589.153.0	1	shoulder ring 15.2 x 19 x 1.00
38.5	2.1589.146.0	2	shoulder ring 15.2 x 19 x 0.15
38.6	2.1589.147.0	2	shoulder ring 15.2 x 19 x 0.10
38.7	2.2020.001.0	1	ball bearing 15 x 32 x 8.00
38.8	2.1589.148.0	1	shoulder ring 28.2 x 31.8 x 0.5
38.9	2.1589.150.0	2	shoulder ring 28.2 x 31.8 x 0.1
38.10	2.1589.151.0	2	shoulder ring 28.2 x 31.8 x 0.15
38.11.1	0.065.1558.6/10	1	bevel drive
38.11.2	0.065.1559.0	1	bush
38.12	2.2680.020.0	1	ring 12 x 15 x 12
38.13	2.2725.016.0	1	roller cage 15 x 21 x 12
38.14	2.0342.007.2	1	screw m 4 p.0.7x25
38.15	2.0399.128.2/10	1	screw m 8 p.1 x 8
38.16	2.2030.002.0	1	ball bearing 12 x 28 x 8
40	0.065.1569.0/40	1	shaft
41	0.065.1562.0/10	1	joint
42	0.014.7994.4	1	oil pump
43	2.1470.006.2	2	lock washer 10
44	2.0112.323.2	2	screw m 10 p.1.5x70

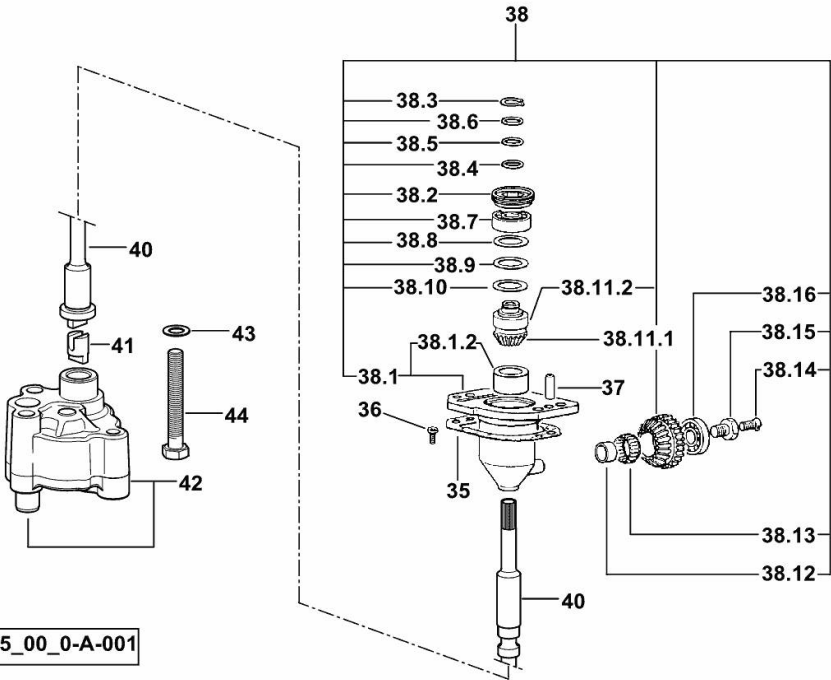

19_M3515_00_0-A-001

Section: B0 - ENGINE

LUBRICATION

Fig.	P/n	QTY	Name
------	-----	-----	------

Notes:
[36 DI - LD 2WD]

1	0.065.1160.3/20	2	valve
50	2.1099.108.2	2	special nut m 10 p.1
51	2.1560.006.0	8	gasket 10.2 x 16
52	0.086.1550.2	2	sprayer nozzle
55	2.0312.221.2	2	screw m 8 p.1.25x75
56	2.1480.014.1	2	washer 8
57	0.012.0688.4	1	sediment bowl
57.1	0.066.1553.0	1	cover
57.2	0.066.1554.0/20	1	gasket
57.3	2.0399.304.2	4	screw m 4 x 10
57.4.1	0.066.1555.0	1	tube
57.4.2	0.012.0688.0	1	small tank
58	2.1532.012.0	1	oil seal 6.75 x 1.78
59	2.1539.072.0	2	special oil seal 23.52 x 1.78
60	0.066.1558.0	1	bush
61	0.066.1557.2	1	tube
62	2.3350.003.1	1	nosepiece 8
63	2.3339.418.1	1	pipe fitting m 12 p.1

19_M3515_00_0-C-001

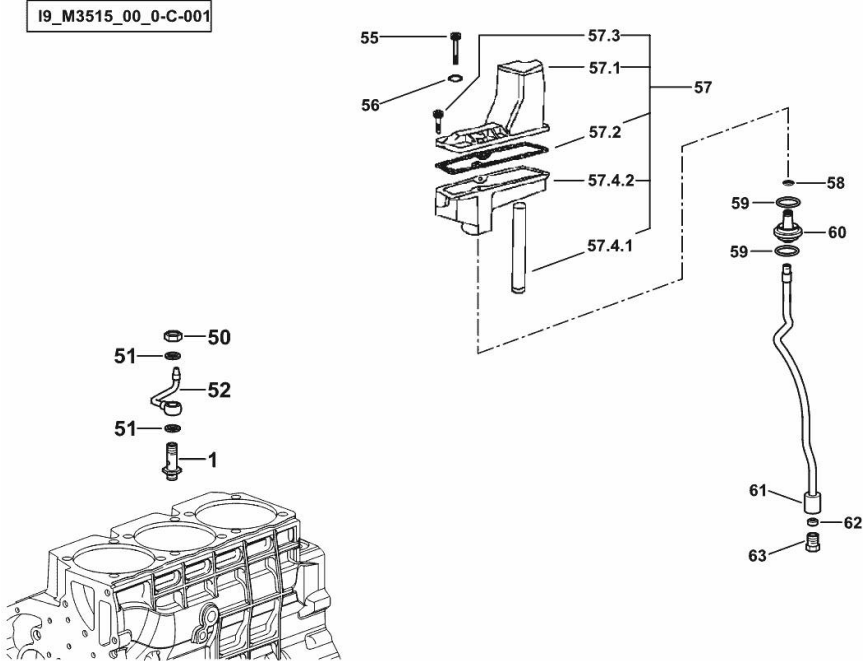

LUBRICATION

Fig.	P/n	QTY	Name
------	-----	-----	------

Notes:

[36 DI - LD 2WD]

2	0.041.1135.4	1	plug 1" gas
2.2	2.1569.072.0	1	gasket 32 x 39.5 x 2
3	2.0312.205.2	2	screw
4	2.1480.014.1	2	washer 8
5	0.012.0613.0	1	pipe union
6	0.065.1567.0/10	1	filter
7	0.065.1566.0	1	gasket
15	0.012.0684.0	1	none
16	0.012.0682.2	1	dipstick
17	2.1539.065.0	1	special oil seal 8.73 x 1.78

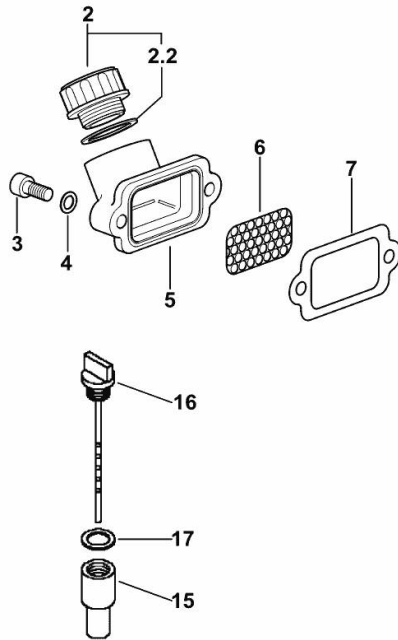

19_M3515_00_0-B-001

SEDIMENTER BOWL BREATHER PIPE

Fig.	P/n	QTY	Name
------	-----	-----	------

Notes:

[36 DI - LD 2WD]

14	0.066.1559.0	1	tube
16	2.6859.073.2	1	clamp

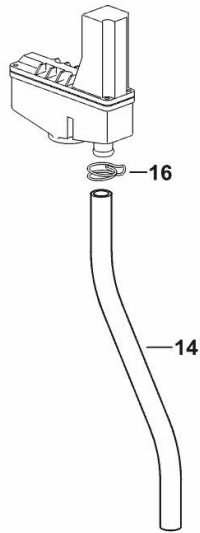

I9_38519_11_0-C-001

PIPE FOR OIL PRESSURE SENSOR

Fig.	P/n	QTY	Name
------	-----	-----	------

Notes:

[36 DI - LD 2WD] -> 11056

2	0.010.4868.3	1	tube
3	2.3249.014.2	1	pipe fitting m 12 p.1.5
4	2.3339.746.2	1	pipe union
5	2.0432.013.7	1	stud bolt m 8 p.1.25 / p.1 x 45
6	2.1560.008.0	3	gasket 12.2 x 18

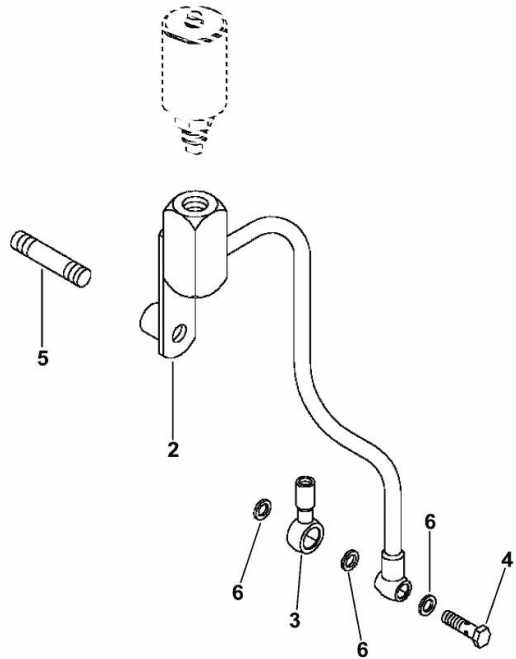

I9_38515_03_0-B-001

FUEL SETTLING FILTER VENT HOSE BRACKET

Fig.	P/n	QTY	Name
------	-----	-----	------

Notes:

[36 DI - LD 2WD]

2	0.075.1151.0	1	bracket
---	--------------	---	---------

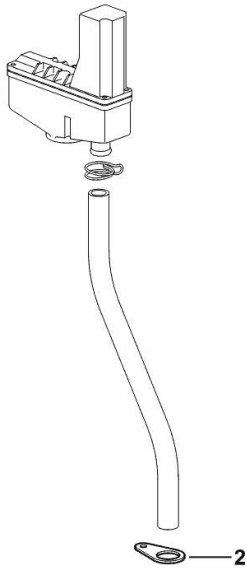

I9_N8019_12_0-B-001

OIL PAN

Fig.	P/n	QTY	Name
------	-----	-----	------

Notes:

[36 DI - LD 2WD] 17759 <-

19_M3515_03_0-A-001

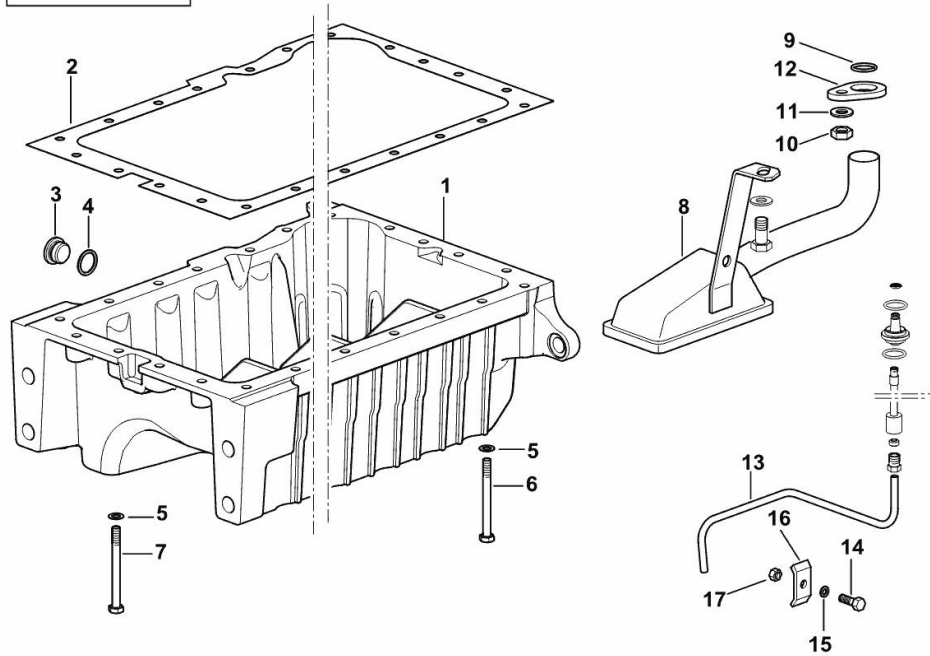

1	0.013.1692.0/10	1	oil sump
2	0.013.1728.0	1	gasket
3	2.1560.054.0	1	gasket 21 x 26
4	0.012.0666.0	1	plug 1/2" gas
5	2.1470.004.2	18	lock washer 8
6	2.0112.226.2	9	screw m 8 p.1.25 x 85
7	2.0112.215.2	9	screw m 8 p.1.25 x 40
8	0.013.1693.3/10	1	tube
9	2.1539.040.0	1	special oil seal 21.82 x 3.53
10	2.1011.105.2	1	nut m 8 p.1.25
11	2.1470.004.2	2	lock washer 8
12	0.065.1538.0	1	flange
13	0.013.1695.0	1	tube
14	2.0112.007.2	1	screw m 6 p.1 x 20
15	2.1470.002.2	1	lock washer 6
16	0.002.8816.0	1	small plate
17	2.1011.103.2	1	nut m 6 p.1

LUBRICATION - STEEL PLATE OIL SUMP

Fig.	P/n	QTY	Name
------	-----	-----	------

Notes:

[36 DI - LD 2WD] -> 20271

1	0.012.9780.2	1	oil sump
2	0.012.0666.0	1	plug 1/2" gas
3	2.1560.054.0	1	gasket 21 x 26
4	2.0112.209.2	1	screw m 8 p 1.25 x 25
5	2.0112.205.2	17	screw m 8 p.1.25 x 16
6	2.1470.004.2	18	lock washer 8
8	0.012.9793.3	1	tube
9	2.1539.040.0	1	special oil seal 21.82 x 3.53
10	2.1011.105.2	1	nut m 8 p.1.25
11	2.1470.004.2	1	lock washer 8
12	0.065.1538.0	1	flange
13	2.1470.004.2	1	lock washer 8
14	2.0112.205.2	1	screw m 8 p.1.25 x 16
15	0.012.9796.0	1	tube
16	2.0112.007.2	1	screw m 6 p.1 x 20
17	2.1470.002.2	1	lock washer 6
18	0.002.8816.0	1	small plate
19	2.1011.103.2	1	nut m 6 p.1

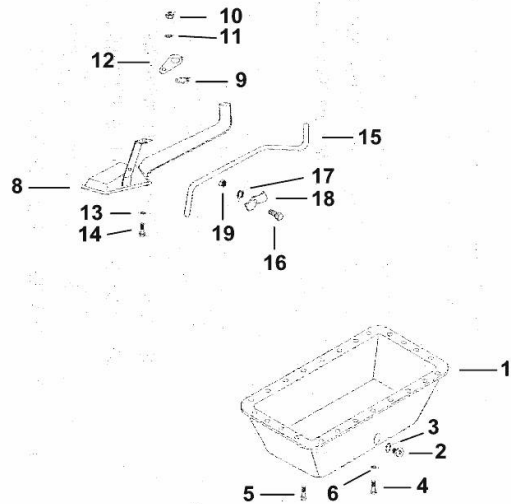

19_M3515_02_0-A-001

Thank you so much for reading.
Please click the “Buy Now!”
button below to download the
complete manual.



After you pay.

You can download the most
perfect and complete manual in
the world immediately.

Our support email:

ebooklibonline@outlook.com