

CRANKCASE

Fig.	P/n	QTY	Name
------	-----	-----	------

Notes:

[453 DX LD 2WD]-> 10011 - 22111 <-

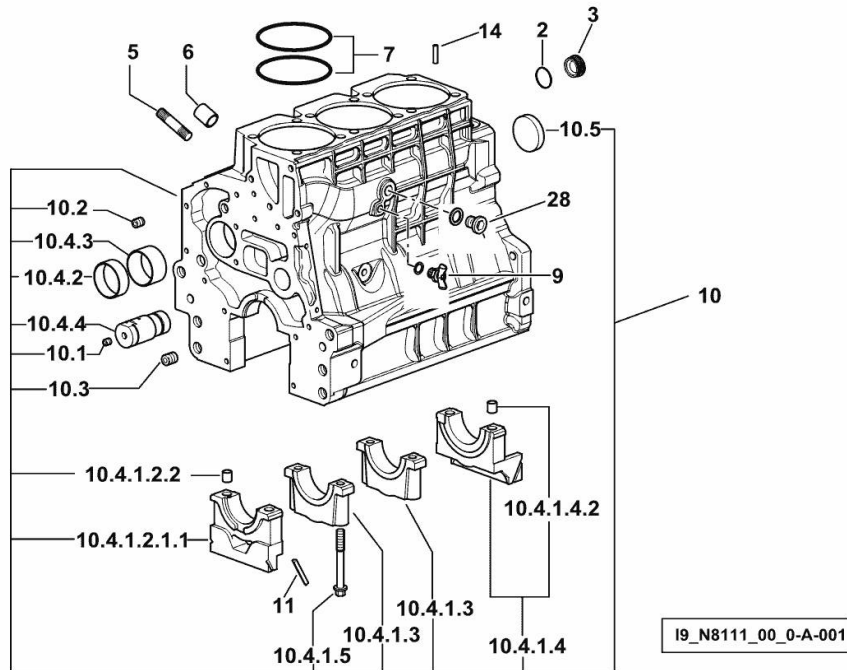

2	2.1532.072.0	1	oil seal 26.70x1.78
3	2.3199.405.2	1	plug m 28 p.1.5
5	2.0432.003.7	11	stud bolt m 8 p.1.25 / p.1 x 20
6	2.1559.188.2	3	bush 11.4 x 14 x16
7	2.1539.259.0	6	special oil seal 107.62x2.62
9	0.049.1152.0	1	cock
10	0.014.8700.4	1	crankcase
10.1	2.3130.001.1	9	plug 1/8" gas
10.2	2.3130.002.1	2	plug 1/4" gas
10.3	2.3130.003.1	2	plug 3/8" gas
10.4.1.2.1.1	0.065.1112.7/10	1	support
10.4.1.2.2	2.1699.165.0	1	bush 12.3x15x16
10.4.1.3	0.065.1114.0/10	2	support
10.4.1.4	0.065.1116.3	1	support
10.4.1.4.2	2.1699.165.0	1	bush 12.3x15x16
10.4.1.5	0.065.1117.0	8	screw m 12 x 100
10.4.2	0.065.1140.0	3	special bushing 59X55X20
10.4.3	0.065.1141.0	1	special bushing 59X55X30
10.4.4	0.014.1340.0	1	pin
10.5	2.3179.012.0	1	plug 60
11	0.066.1152.0/10	4	gasket
14	2.1549.154.2	3	bush 4.8x5.8x16
28	2.3131.004.2	1	plug m 18 p.1.5

Section: B0 - ENGINE

CRANKCASE

Fig.	P/n	QTY	Name
------	-----	-----	------

Notes:

[453 DX LD 2WD] -> 21641

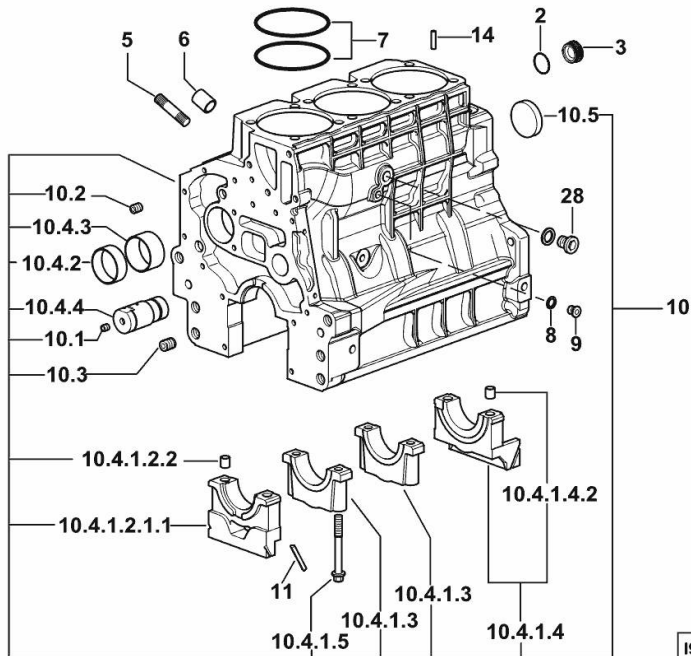

19_N8111_00_0-A-002

2	2.1532.072.0	1	oil seal 26.70x1.78
3	2.3199.405.2	1	plug m 28 p.1.5
5	2.0432.003.7	11	stud bolt m 8 p.1.25 / p.1 x 20
6	2.1559.188.2	3	bush 11.4 x 14 x16
7	2.1539.259.0	6	special oil seal 107.62x2.62
8	2.1560.010.0	1	gasket 14.2 x 20
9	2.3199.292.0	1	plug 1/4" gas
10	0.014.8700.4	1	crankcase
10.1	2.3130.001.1	9	plug 1/8" gas
10.2	2.3130.002.1	2	plug 1/4" gas
10.3	2.3130.003.1	2	plug 3/8" gas
10.4.1.2.1.1	0.065.1112.7/10	1	support
10.4.1.2.2	2.1699.165.0	1	bush 12.3x15x16
10.4.1.3	0.065.1114.0/10	2	support
10.4.1.4	0.065.1116.3	1	support
10.4.1.4.2	2.1699.165.0	1	bush 12.3x15x16
10.4.1.5	0.065.1117.0	8	screw m 12 x 100
10.4.2	0.065.1140.0	3	special bushing 59X55X20
10.4.3	0.065.1141.0	1	special bushing 59X55X30
10.4.4	0.014.1340.0	1	pin
10.5	2.3179.012.0	1	plug 60
11	0.066.1152.0/10	4	gasket
14	2.1549.154.2	3	bush 4.8x5.8x16
28	2.3131.004.2	1	plug m 18 p.1.5

MONOBLOC ENGINE-GEARBOX CONNECTING FLANGE

Fig.	P/n	QTY	Name
------	-----	-----	------

Notes:

[453 DX LD 2WD] -> 16541

1	0.015.8814.0	1	flange
2	2.0112.511.2	8	screw m 14 p.2 x 30
3	2.0432.255.7	2	stud bolt m 12 p.1.75-1.25x25
4	2.1651.912.0	4	cylindrical plug 12x28
5	2.0512.404.7	2	screw

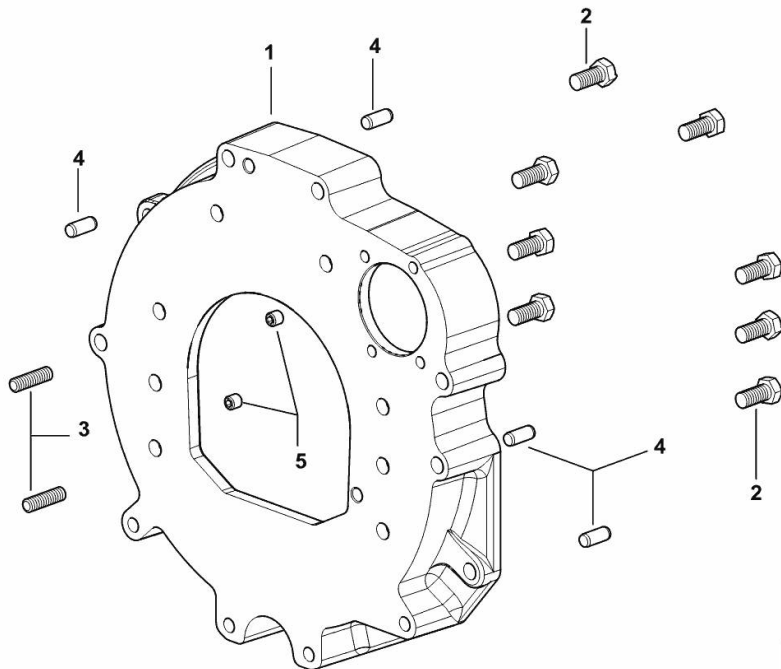

I9_38511_01_0-A-001

CRANKSHAFT

Fig.	P/n	QTY	Name
------	-----	-----	------

Notes:

[453 DX LD 2WD] -> 10011 - 22422 <-

7.1	0.007.1554.0/20	1	crankshaft
8	0.065.1215.0/10	4	main half bushing STANDARD
9	0.065.1216.0/10	4	main half bushing STANDARD
10	0.065.1218.0	4	shim STANDARD
15	0.065.1254.0/20	1	gasket
16	0.007.1711.0/10	1	cover
17	2.1475.002.2	9	conical washer 8
18	2.0112.207.2	9	screw m 8 p 1.25 x 20
19	2.1529.073.0	1	special oil seal 110x130x13
22	2.1599.524.7	1	washer 21x60x12
23	0.065.1323.0/30	1	gear Z = 29
24	2.1651.915.0	1	pin 12x35
25	2.3130.001.1	3	plug 1/8" gas
26	2.1720.006.0	1	key 4x6.5
801	0.065.1215.7	1	main half bushing - mm 0.25
802	0.065.1215.8	1	main half bushing - mm 0.50
901	0.065.1216.7	1	main half bushing - mm 0.25
902	0.065.1216.8	1	main half bushing - mm 0.50
1001	0.065.1218.7	1	shim + mm 0.10
1002	0.065.1218.8	1	shim + mm 0.15

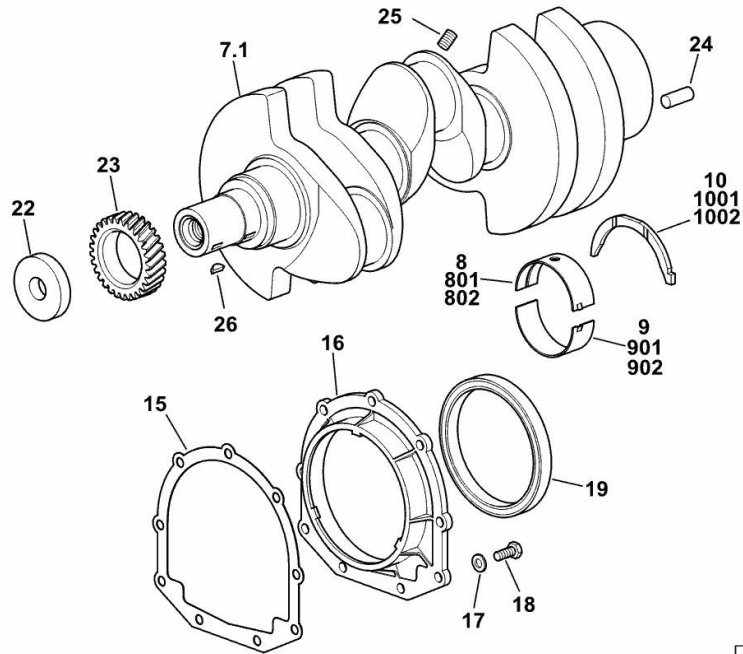

19_N8112_00_0-A-001

Section: B0 - ENGINE

CRANKSHAFT

Fig.	P/n	QTY	Name
------	-----	-----	------

Notes:

[453 DX LD 2WD]

7	0.019.2255.0/20	1	crankshaft
8	0.019.5455.0	4	main half bushing STANDARD
9	0.019.5456.0	4	main half bushing STANDARD
10	0.065.1218.0	4	shim STANDARD
15	0.065.1254.0/20	1	gasket
16	0.007.1711.0/10	1	cover
17	2.1475.002.2	9	conical washer 8
18	2.0112.207.2	9	screw m 8 p 1.25 x 20
19	2.1529.073.0	1	special oil seal 110x130x13
22	2.1599.524.7	1	washer 21x60x12
23	0.065.1323.0/30	1	gear Z = 29
24	2.1651.915.0	1	pin 12x35
26	2.1720.006.0	1	key 4x6.5
1001	0.065.1218.7	1	shim + mm 0.10
1002	0.065.1218.8	1	shim + mm 0.15

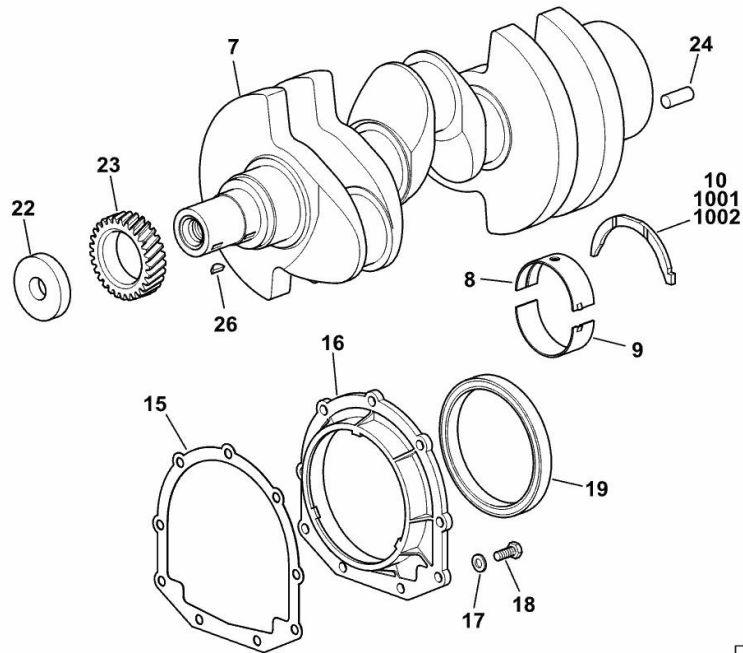

19_N8112_00_0-A-002

Section: B0 - ENGINE

CRANKSHAFT PULLEY

Fig.	P/n	QTY	Name
------	-----	-----	------

Notes:

[453 DX LD 2WD] -> 10011

3	0.014.5093.0	1	pulley
5	0.085.1248.0/20	1	hub
6	2.0399.144.7/10	1	screw m 20 p.1.5x51
8	2.1720.006.0	1	key 4x6.5

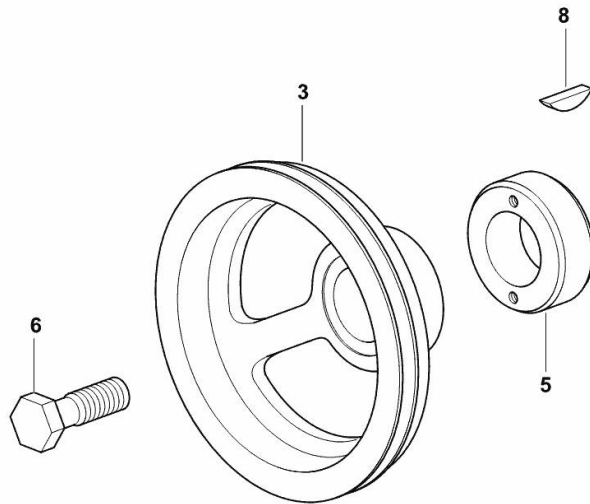

19_38512_04_0-A-001

Section: B0 - ENGINE

CRANKSHAFT PULLEY

Fig.	P/n	QTY	Name
------	-----	-----	------

Notes:

- FOR TYPES WITH AIR BARKING - I.S.R.O. [453 DX LD 2WD]

3	0.012.0659.0	1	none
5	0.085.1248.0/20	1	hub
6	2.0399.144.7/10	1	screw m 20 p.1.5x51
8	2.1720.006.0	1	key 4x6.5

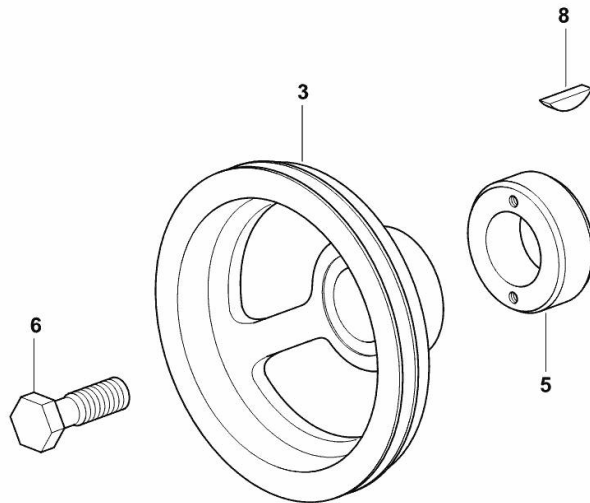

19_38512_11_0-A-001

Section: B0 - ENGINE

ENGINE FLYWHEEL

Fig.	P/n	QTY	Name
------	-----	-----	------

Notes:

[453 DX LD 2WD] -> 10011

1	0.012.0925.3	1	flywheel
1.2	0.069.1242.0	1	crown wheel Z = 121
2	2.0119.174.0/10	6	screw m 12 p.1.25x45
3	2.2041.008.9	1	ball bearing 20x47x14

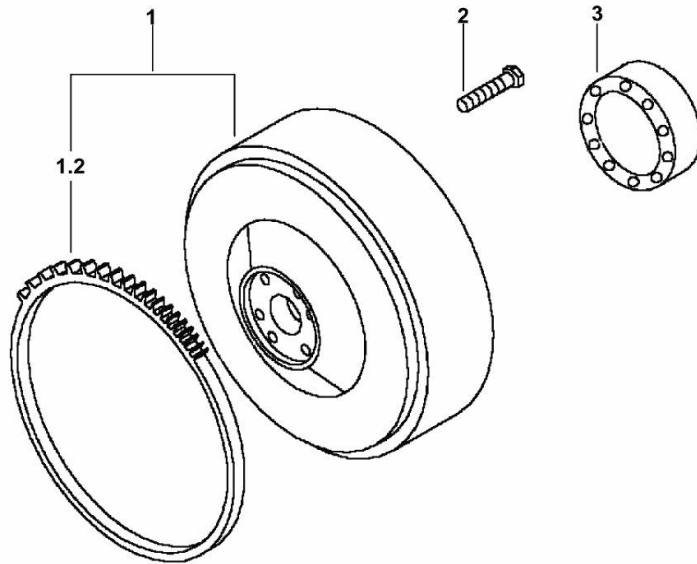

19_38512_02_0-A-001

Section: B0 - ENGINE

ENGINE FLYWHEEL

Fig.	P/n	QTY	Name
------	-----	-----	------

Notes:

[453 DX LD 2WD] -> 10923

1	0.007.1617.3/30	1	flywheel
1.2	0.069.1242.0	1	crown wheel Z = 121
2	2.0119.174.0/10	6	screw m 12 p.1.25x45
3	2.2041.008.9	1	ball bearing 20x47x14

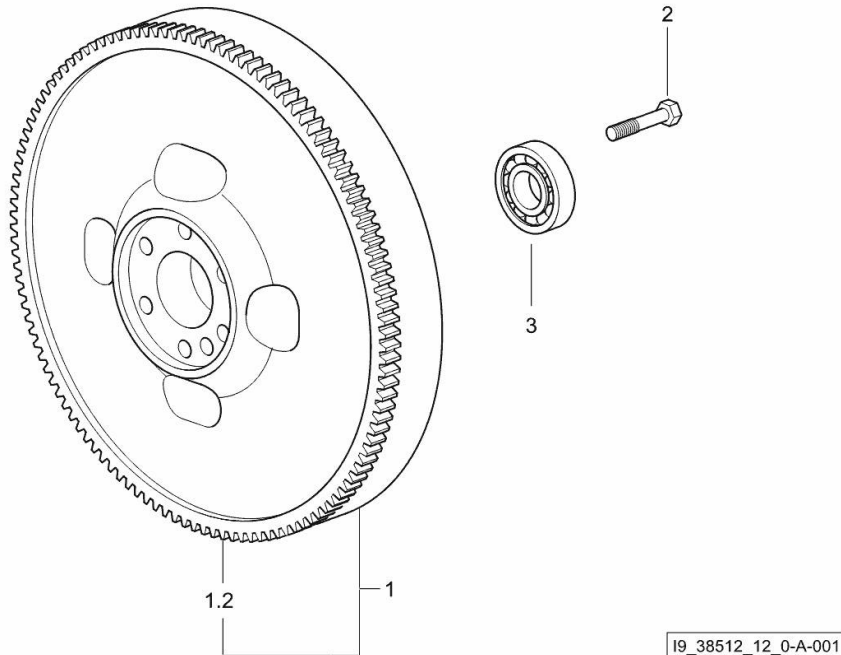

COOLANT PUMP DRIVEBELT

Fig.	P/n	QTY	Name
------	-----	-----	------

Notes:

[453 DX LD 2WD]

31	2.4119.139.0	1	belt mm 10.7x1254 (20357 <-)
31	2.4119.198.0	1	vee belt AV 10.7x1240 mm (-> 20244)

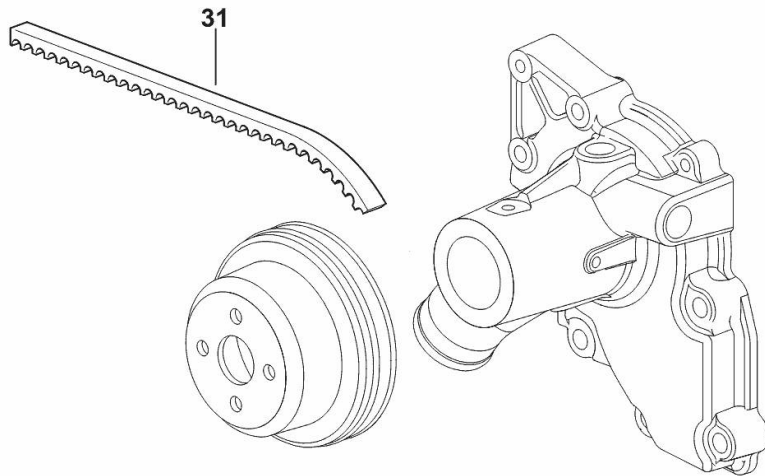

19_38519_11_0-B-001

CYLINDER - PISTON - CONNECTING ROD

Fig.	P/n	QTY	Name
------	-----	-----	------

Notes:
[453 DX LD 2WD]

1	0.386.0065.A	3	cyl. piston assembly "A" - CLASS A
1	0.386.0065.B	3	cyl. piston assembly "B" - CLASS B
1.1	0.A12.2675.0	1	engine cylinder "A" - CLASS A
1.1	0.B12.2675.0	1	engine cylinder "B" - CLASS B
1.2	0.379.0060.A	1	complete piston "A" - CLASS A
1.2	0.379.0060.B	1	complete piston "B" - CLASS B
1.2.1	0.086.0052.6/10	1	piston ring set
1.2.2	2.1411.014.1	1	circlip 35
1.2.3	0.078.1236.0	1	piston pin Ø 18 / Ø 35 / L = mm 86
2	0.065.1225.0	6	con.rod half bushing STANDARD - A = 28.75 -> 29.00 (...) <=
2	0.065.1225.7	6	con.rod half bushing - mm 0.25 (...) <=
2	0.065.1225.8	6	con.rod half bushing - mm 0.50 (...) <=
3	0.019.2226.3/10	1	engine connecting rod => (...)
3	0.078.1220.3/30	1	engine connecting rod (...) <=
3.1	2.0399.213.0	2	screw m 12 p.1.25x61.5 (...) <=
3.1	2.0399.365.0	2	screw m 10 p.1.25x61.5 => (...)
3.2	2.1559.114.0/10	1	special bushing (...) <=
3.2	2.1559.532.0	1	special bushing 34.60x39.130x36.65 => (...)
4	0.019.5453.0	3	con.rod half bushing STANDARD - A = 29.85 -> 30.10 => (...)
5	0.019.5454.0	3	con.rod half bushing STANDARD - A = 29.85 -> 30.10 => (...)

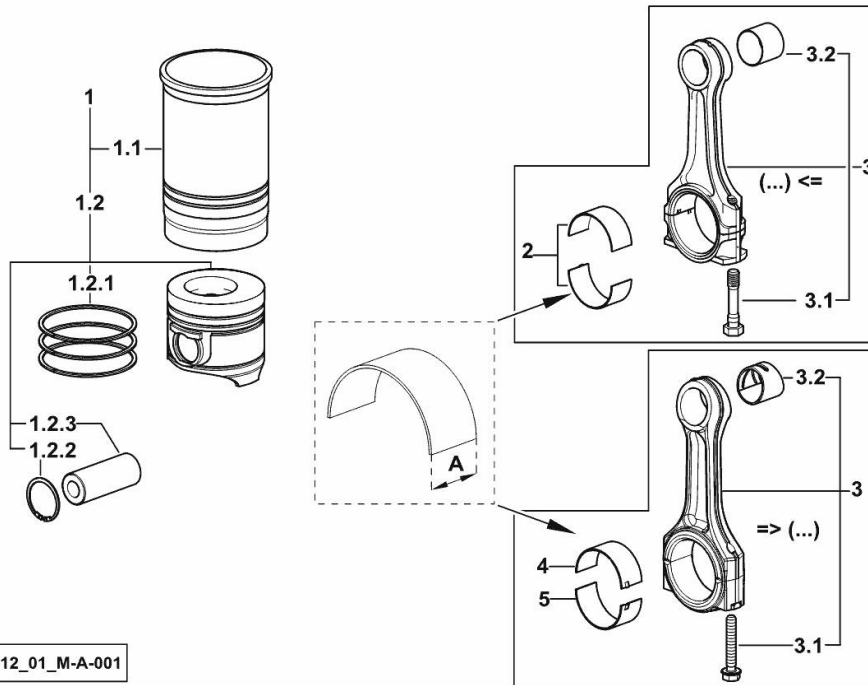

19_N8112_01_M-A-001

Section: B0 - ENGINE

CAMSHAFT

Fig.	P/n	QTY	Name
------	-----	-----	------

Notes:

[453 DX LD 2WD] -> 10011 - 10939 <-

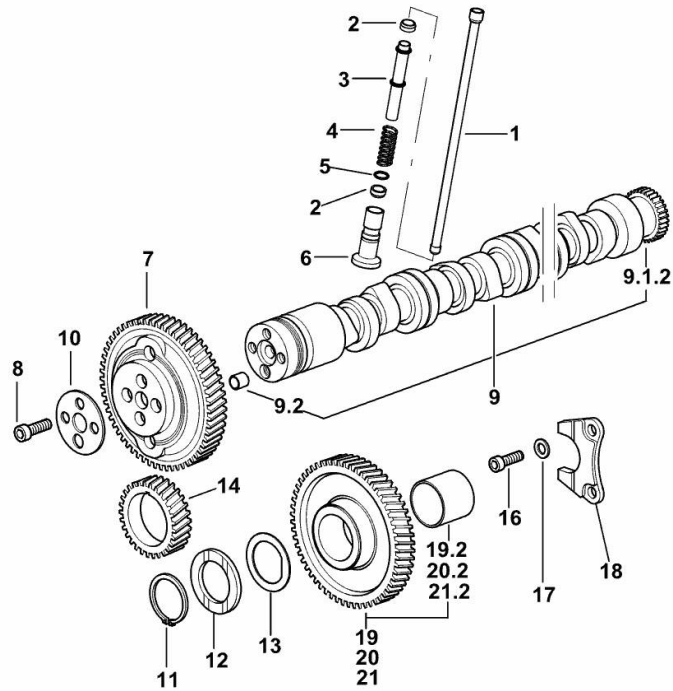

19_N8113_00_0-A-001

1	0.065.1331.2	6	rod
2	2.1569.114.0/10	12	gasket 14x18.5x8
3	0.065.1332.0	6	sleeve
4	2.4019.300.1/10	6	spring 18.5x52x2
5	2.1599.437.0	6	shoulder ring
6	0.065.1330.0	6	tappets
7	0.013.5017.0	1	gear z=58
8	2.0132.207.2	4	screw m 10 p.1 x 25
9	0.014.1945.4	1	camshaft
9.1.2	0.065.1324.0/10	1	gear Z = 32
9.2	2.1559.398.0	1	bushing 10.5x13x12
10	0.065.1350.0	1	small disc
11	2.1410.016.1	1	circlip 40
12	0.065.1352.0	1	shim
13	0.065.1351.0	2	shoulder ring
14	0.065.1323.0/30	1	gear Z = 29
16	2.0312.205.2	2	screw
17	2.1480.014.1	2	washer 8
18	0.065.1353.0	1	small plate
19	0.007.1177.3/20	0.1	gear z = 57
19.2	2.1559.185.0/10	1	bushing
20	0.007.1178.3/20	0.1	gear z = 57
20.2	2.1559.185.0/10	1	bushing
21	0.007.1179.3/20	0.8	gear z = 57
21.2	2.1559.185.0/10	1	bushing

Section: B0 - ENGINE

CAMSHAFT

Fig.	P/n	QTY	Name
------	-----	-----	------

Notes:

[453 DX LD 2WD] -> 10972

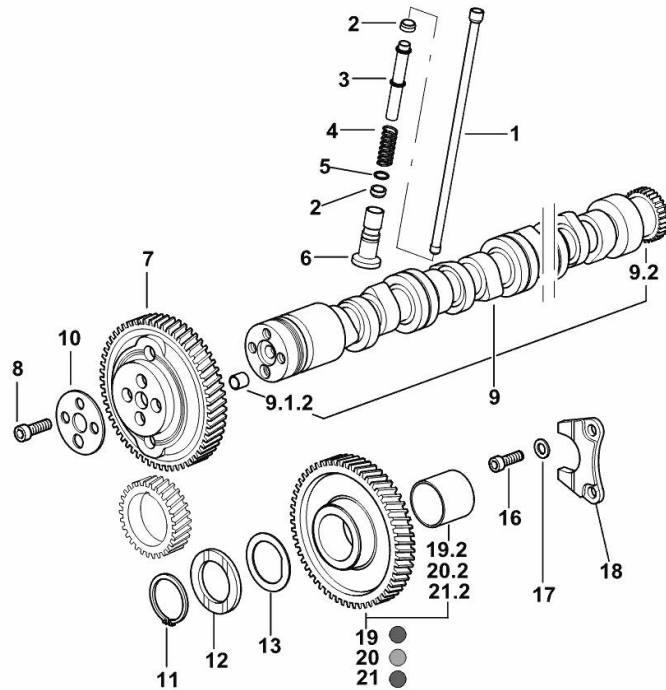

19_N8113_00_0-A-002

1	0.065.1331.2	6	rod
2	2.1569.114.0/10	12	gasket 14x18.5x8
3	0.065.1332.0	6	sleeve
4	2.4019.300.1/10	6	spring 18.5x52x2
5	2.1599.437.0	6	shoulder ring
6	0.065.1330.0	6	tappets
7	0.013.5017.0	1	gear z=58
8	2.0132.207.2	4	screw m 10 p.1 x 25
9	0.012.8270.4	1	camshaft
9.1.2	2.1559.398.0	1	bushing 10.5x13x12
9.2	0.065.1324.0/10	1	gear Z = 32
10	0.065.1350.0	1	small disc
11	2.1410.016.1	1	circlip 40
12	0.065.1352.0	1	shim
13	0.018.2233.0	2	shoulder ring
16	2.0312.205.2	2	screw
17	2.1480.014.1	2	washer 8
18	0.065.1353.0	1	small plate
19	0.007.1177.3/20	0.1	gear z = 57 - WITH RED IDENTIFICATION STAMP
19.2	2.1559.185.0/10	1	bushing
20	0.007.1178.3/20	0.1	gear z = 57 - WITH YELLOW IDENTIFICATION STAMP
20.2	2.1559.185.0/10	1	bushing
21	0.007.1179.3/20	0.8	gear z = 57 - WITH GREEN IDENTIFICATION STAMP
21.2	2.1559.185.0/10	1	bushing

Section: B0 - ENGINE

TIMING CASE

Fig.	P/n	QTY	Name
------	-----	-----	------

Notes:

[453 DX LD 2WD] -> 10011

5	2.0432.003.7	11	stud bolt m 8 p.1.25 / p.1 x 20
16	2.0312.214.2	7	screw m 8 p.1.25 x 40
17	2.1480.014.1	15	washer 8
18	0.013.4981.0	1	guard
19	0.065.1150.0/30	1	gasket
20	2.1470.004.2	2	lock washer 8
21	2.1011.405.2	2	nut m 8 p.1
22	2.0312.208.2	8	screw m 8 p.1.25 x 25
23	2.1529.167.0	1	oil seal

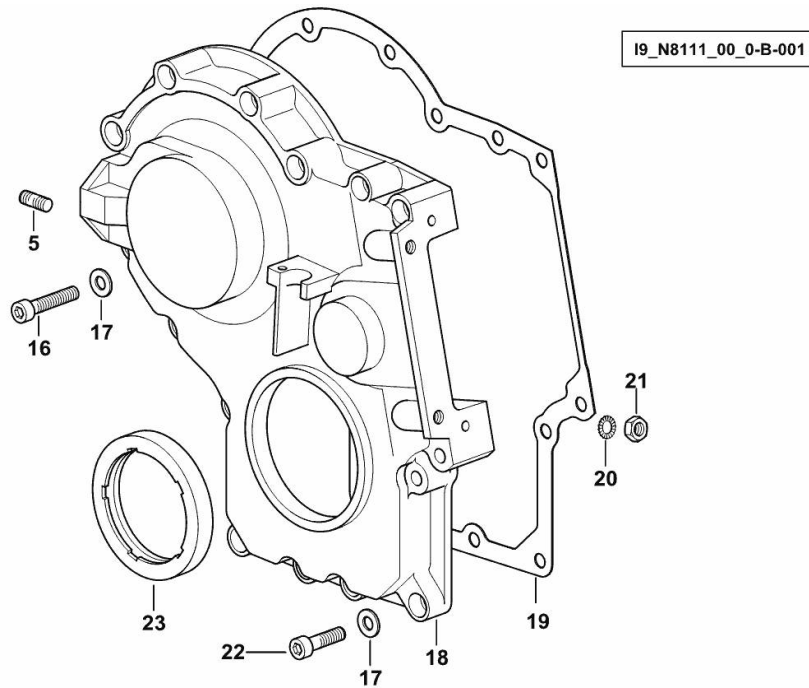

Section: B0 - ENGINE
CYLINDER HEAD

Fig.	P/n	QTY	Name
------	-----	-----	------

Notes:

[453 DX LD 2WD] -> 10011

1	2.0399.130.2/10	3	screw m 8x36x44
2	2.1569.170.0/10	3	gasket 8.2 x 14
3	0.016.0291.0	3	small cap
4	0.069.1450.0/30	1	tappet gasket
7	2.1011.421.2	6	nut m 10 p.1.25
9.2	0.021.1434.0	2	screw
9.10.3	2.1011.405.2	2	nut m 8 p.1
9.10.4	0.066.1432.3	2	rocker arm
9.10.4.2	2.1559.021.0/40	1	bushing 15x19x22
9.10.5	2.1410.055.7	2	circlip 19
9.10.6.1	0.066.1431.0	1	pin
9.10.6.2	0.066.1430.0/10	1	support
9.10.7	2.1599.432.0	2	shoulder ring
16	2.1530.051.0	3	oil seal 20.22x3.53
17	0.012.2673.0	12	screw m 14 p.2x141
18.1	0.014.8945.3/10	1	head
18.1.2	0.014.8942.0	1	valve seat mm 45.118
18.1.3	0.014.8941.0	1	valve seat mm 40.653
18.1.4	0.007.1779.0/20	2	valve guide
18.1.5	0.010.6041.0/10	1	bush
18.1.6	2.3170.012.2	2	expansion plug Ø 30
18.2	0.066.1421.0	1	exhaust valve
18.3	0.010.6016.0	1	inlet valve mm 43.63 / Ø mm 9
18.4	0.066.1425.0	2	cup
18.5	0.074.1423.0	4	conical valve cotter
18.6	2.4019.287.0	2	spring
18.7	2.1519.117.0	2	special oil seal
18.8	2.0432.161.7	1	stud bolt m 10 p.1.5 / p.1.25 x 40
18.9	2.0432.163.7	2	stud bolt m 10 p.1.5 / p.1.25 x 45
20	2.0432.011.7	3	stud bolt m 8 p.1.25 / p.1 x 40
21	2.0432.005.7	3	stud bolt m 8 p.1.5 / p.1 x 25
25	0.014.5260.0/10	0.5	gasket - A - mm 1.4
26	0.014.5259.0/10	2	gasket - B - mm 1.2
27	0.014.5261.0/10	0.5	gasket - C - mm 1.6

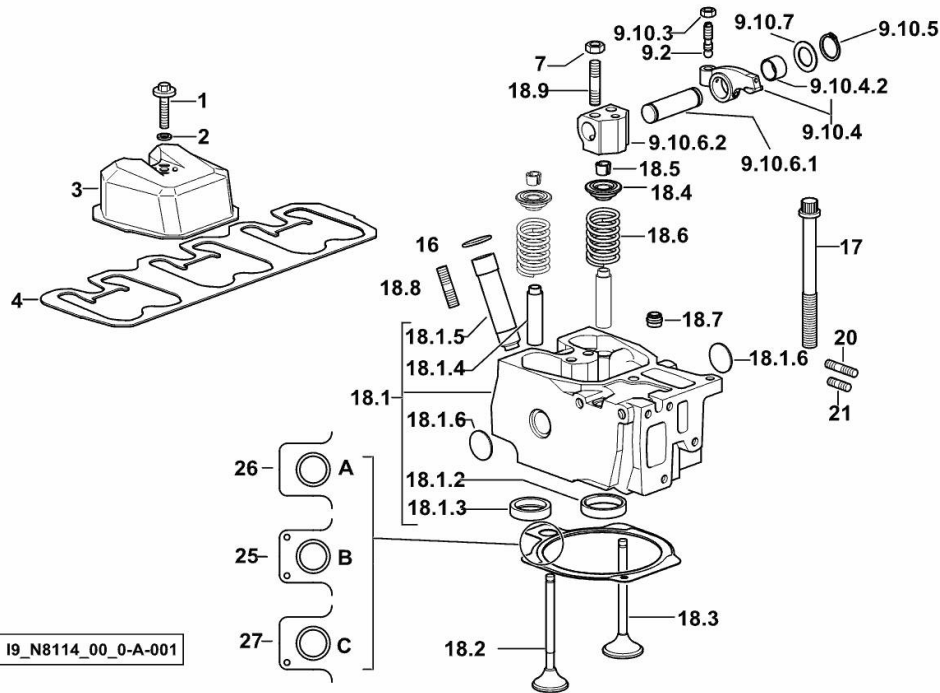

Thank you so much for reading.
Please click the “Buy Now!”
button below to download the
complete manual.



After you pay.

You can download the most
perfect and complete manual in
the world immediately.

Our support email:

ebooklibonline@outlook.com