

## Section: B0 - ENGINE

**CRANKCASE**

Fig.	P/n	QTY	Name
------	-----	-----	------

**Notes:**

[SAME 50]

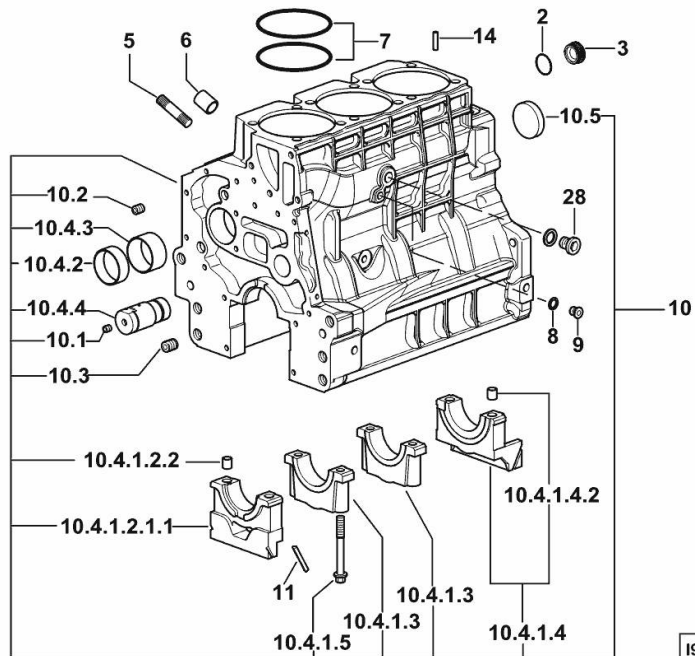

2	2.1532.072.0	1	oil seal 26.70x1.78
3	2.3199.405.2	1	plug m 28 p.1.5
5	2.0432.003.7	11	stud bolt m 8 p.1.25 / p.1 x 20
6	2.1559.188.2	3	bush 11.4 x 14 x16
7	2.1539.259.0	6	special oil seal 107.62x2.62
8	2.1560.010.0	1	gasket 14.2 x 20
9	2.3199.292.0	1	plug 1/4" gas
10	0.014.8700.4	1	crankcase
10.1	2.3130.001.1	9	plug 1/8" gas
10.2	2.3130.002.1	2	plug 1/4" gas
10.3	2.3130.003.1	2	plug 3/8" gas
10.4.1.2.1.1	0.065.1112.7/10	1	support
10.4.1.2.2	2.1699.165.0	1	bush 12.3x15x16
10.4.1.3	0.065.1114.0/10	2	support
10.4.1.4	0.065.1116.3	1	support
10.4.1.4.2	2.1699.165.0	1	bush 12.3x15x16
10.4.1.5	0.065.1117.0	8	screw m 12 x 100
10.4.2	0.065.1140.0	3	special bushing 59X55X20
10.4.3	0.065.1141.0	1	special bushing 59X55X30
10.4.4	0.014.1340.0	1	pin
10.5	2.3179.012.0	1	plug 60
11	0.066.1152.0/10	4	gasket
14	2.1549.154.2	3	bush 4.8x5.8x16
28	2.3131.004.2	1	plug m 18 p.1.5

19\_N8111\_00\_0-A-002

**MONOBLOC ENGINE-GEARBOX CONNECTING FLANGE**

Fig.	P/n	QTY	Name
------	-----	-----	------

**Notes:**

[SAME 50]

1	0.015.8814.0	1	flange
2	2.0112.511.2	8	screw m 14 p.2 x 30
3	2.0432.255.7	2	stud bolt m 12 p.1.75-1.25x25
4	2.1651.912.0	4	cylindrical plug 12x28
5	2.0512.404.7	2	screw

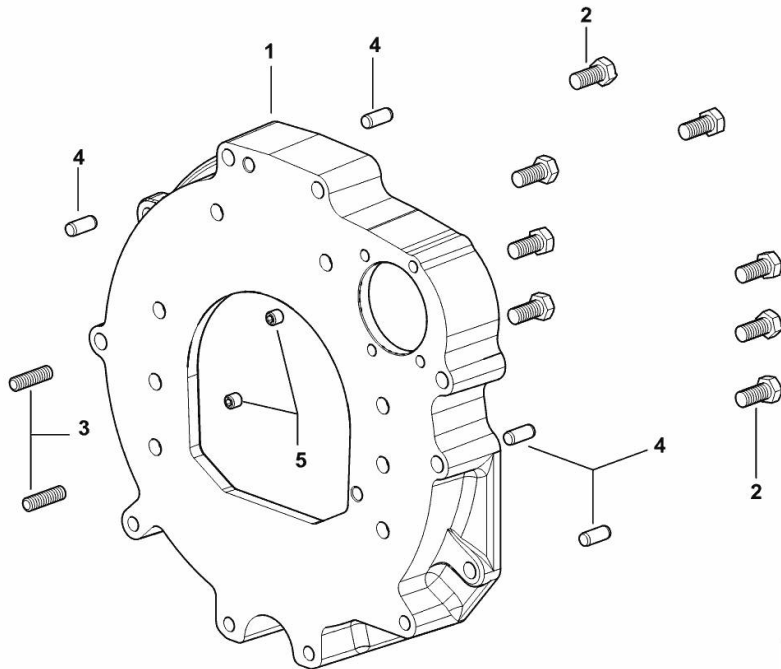

**CRANKSHAFT**

Fig.	P/n	QTY	Name
------	-----	-----	------

**Notes:**

[SAME 50] 23076 &lt;-

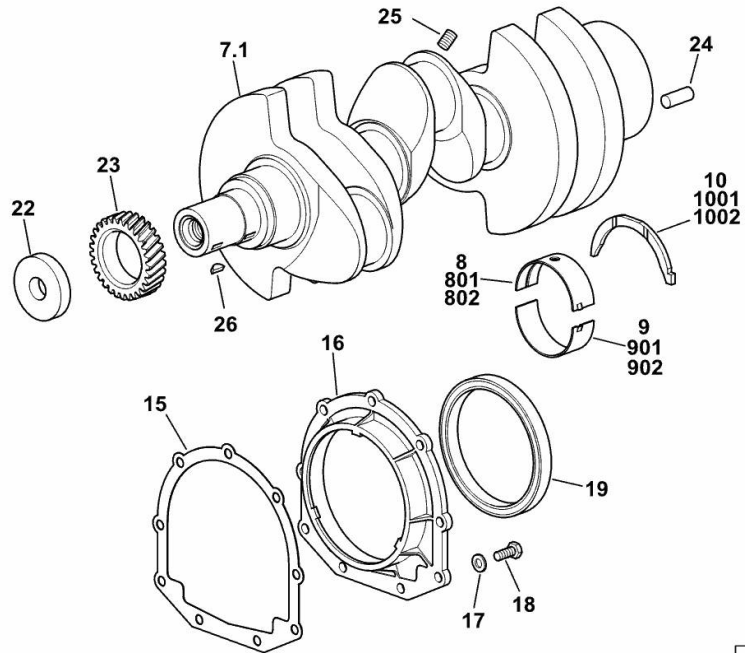

7.1	0.007.1554.0/20	1	crankshaft
8	0.065.1215.0/10	4	main half bushing STANDARD
9	0.065.1216.0/10	4	main half bushing STANDARD
10	0.065.1218.0	4	shim STANDARD
15	0.065.1254.0/20	1	gasket
16	0.007.1711.0/10	1	cover
17	2.1475.002.2	9	conical washer 8
18	2.0112.207.2	9	screw m 8 p 1.25 x 20
19	2.1529.073.0	1	special oil seal 110x130x13
22	2.1599.524.7	1	washer 21x60x12
23	0.065.1323.0/30	1	gear Z = 29
24	2.1651.915.0	1	pin 12x35
25	2.3130.001.1	3	plug 1/8" gas
26	2.1720.006.0	1	key 4x6.5
801	0.065.1215.7	1	main half bushing - mm 0.25
802	0.065.1215.8	1	main half bushing - mm 0.50
901	0.065.1216.7	1	main half bushing - mm 0.25
902	0.065.1216.8	1	main half bushing - mm 0.50
1001	0.065.1218.7	1	shim + mm 0.10
1002	0.065.1218.8	1	shim + mm 0.15

19\_N8112\_00\_0-A-001

**CRANKSHAFT**

Fig.	P/n	QTY	Name
------	-----	-----	------

**Notes:**

[SAME 50] -&gt; 23169

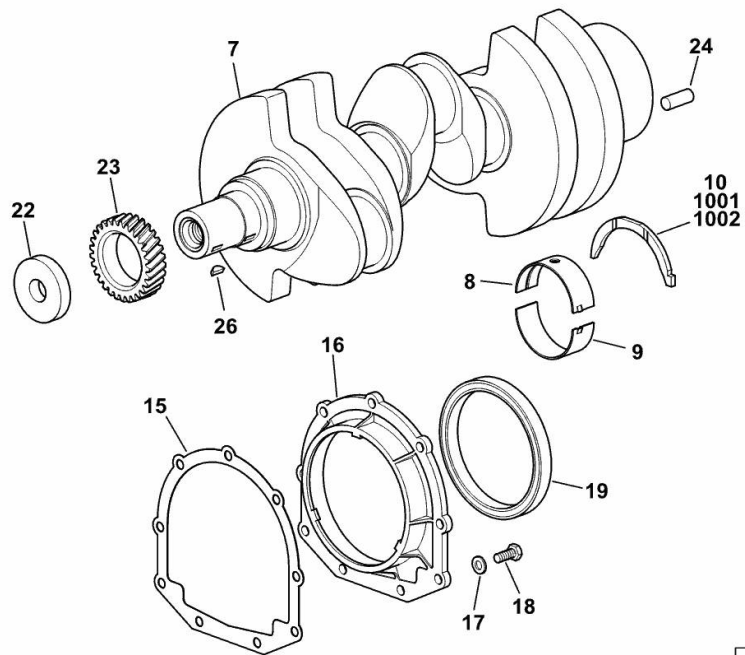

19\_N8112\_00\_0-A-002

7	0.019.2255.0/20	1	crankshaft
8	0.019.5455.0	4	main half bushing STANDARD
9	0.019.5456.0	4	main half bushing STANDARD
10	0.065.1218.0	4	shim STANDARD
15	0.065.1254.0/20	1	gasket
16	0.007.1711.0/10	1	cover
17	2.1475.002.2	9	conical washer 8
18	2.0112.207.2	9	screw m 8 p 1.25 x 20
19	2.1529.073.0	1	special oil seal 110x130x13
22	2.1599.524.7	1	washer 21x60x12
23	0.065.1323.0/30	1	gear Z = 29
24	2.1651.915.0	1	pin 12x35
26	2.1720.006.0	1	key 4x6.5
1001	0.065.1218.7	1	shim + mm 0.10
1002	0.065.1218.8	1	shim + mm 0.15

**CRANKSHAFT PULLEY**

Fig.	P/n	QTY	Name
------	-----	-----	------

**Notes:**

[SAME 50]

3	0.014.5093.0	1	pulley
5	0.085.1248.0/20	1	hub
6	2.0399.144.7/10	1	screw m 20 p.1.5x51
8	2.1720.006.0	1	key 4x6.5

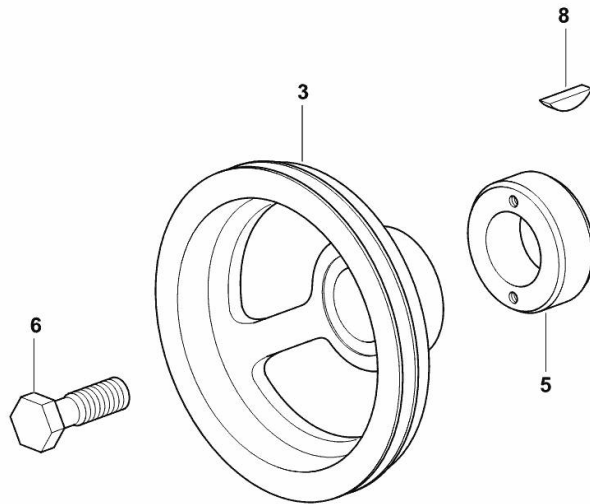

19\_38512\_04\_0-A-001

**CRANKSHAFT PULLEY**

Fig.	P/n	QTY	Name
------	-----	-----	------

**Notes:**

- FOR TYPES WITH AIR BARKING - I.S.R.O. [SAME 50]

3	0.012.0659.0	1	none
5	0.085.1248.0/20	1	hub
6	2.0399.144.7/10	1	screw m 20 p.1.5x51
8	2.1720.006.0	1	key 4x6.5

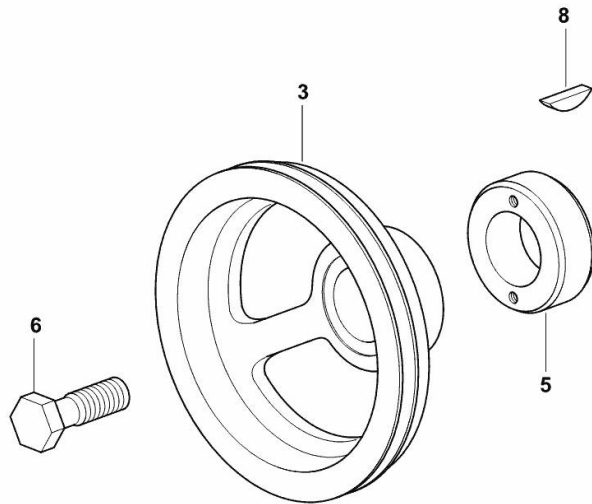

19\_38512\_11\_0-A-001

Section: B0 - ENGINE  
**ENGINE FLYWHEEL**

Fig.	P/n	QTY	Name
------	-----	-----	------

Notes:  
 [SAME 50]

1	0.012.0925.3	1	flywheel
1.2	0.069.1242.0	1	crown wheel Z = 121
2	2.0119.174.0/10	6	screw m 12 p.1.25x45
3	2.2041.008.9	1	ball bearing 20x47x14

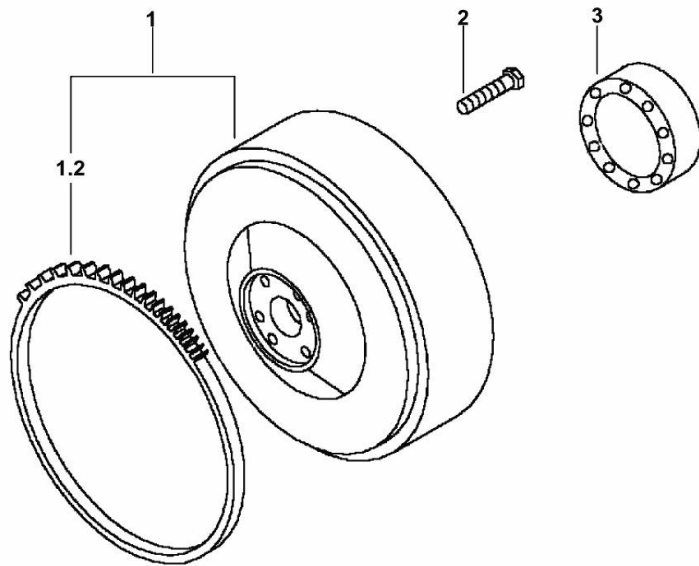

19\_38512\_02\_0-A-001

Section: B0 - ENGINE  
**ENGINE FLYWHEEL**

Fig.	P/n	QTY	Name
------	-----	-----	------

Notes:  
 [SAME 50]

1	0.007.1617.3/30	1	flywheel
1.2	0.069.1242.0	1	crown wheel Z = 121
2	2.0119.174.0/10	6	screw m 12 p.1.25x45
3	2.2041.008.9	1	ball bearing 20x47x14

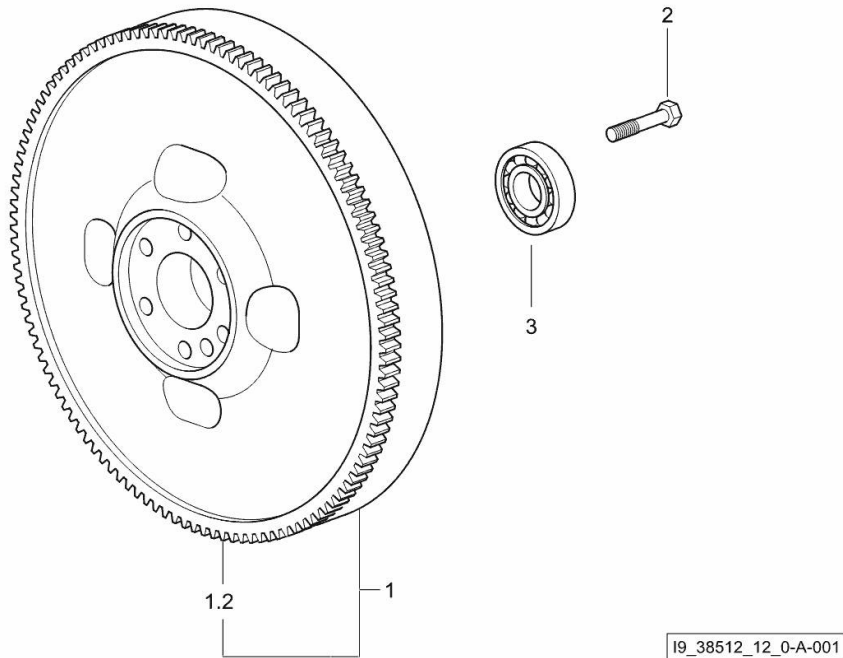



**COOLANT PUMP DRIVEBELT**

Fig.	P/n	QTY	Name
------	-----	-----	------

Notes:  
[SAME 50]

31	2.4119.198.0	1	vee belt AV 10.7x1240 mm ( -> 22405 )
----	--------------	---	---------------------------------------

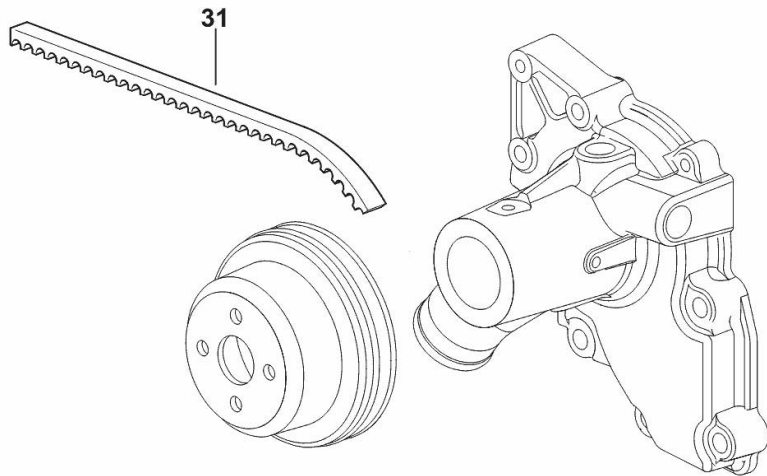

19\_38519\_11\_0-B-001

**CYLINDER - PISTON - CONNECTING ROD**

Fig.	P/n	QTY	Name
------	-----	-----	------

Notes:  
[SAME 50]

1	0.386.0065.A	3	cyl. piston assembly "A" - CLASS A
1	0.386.0065.B	3	cyl. piston assembly "B" - CLASS B
1.1	0.A12.2675.0	1	engine cylinder "A" - CLASS A
1.1	0.B12.2675.0	1	engine cylinder "B" - CLASS B
1.2	0.379.0060.A	1	complete piston "A" - CLASS A
1.2	0.379.0060.B	1	complete piston "B" - CLASS B
1.2.1	0.086.0052.6/10	1	piston ring set
1.2.2	2.1411.014.1	1	circlip 35
1.2.3	0.078.1236.0	1	piston pin Ø 18 / Ø 35 / L = mm 86
2	0.065.1225.0	6	con.rod half bushing STANDARD - A = 28.75 -> 29.00 (...) <=
2	0.065.1225.7	6	con.rod half bushing - mm 0.25 (...) <=
2	0.065.1225.8	6	con.rod half bushing - mm 0.50 (...) <=
3	0.019.2226.3/10	1	engine connecting rod => (...)
3	0.078.1220.3/30	1	engine connecting rod (...) <=
3.1	2.0399.213.0	2	screw m 12 p.1.25x61.5 (...) <=
3.1	2.0399.365.0	2	screw m 10 p.1.25x61.5 => (...)
3.2	2.1559.114.0/10	1	special bushing (...) <=
3.2	2.1559.532.0	1	special bushing 34.60x39.130x36.65 => (...)
4	0.019.5453.0	3	con.rod half bushing STANDARD - A = 29.85 -> 30.10 => (...)
5	0.019.5454.0	3	con.rod half bushing STANDARD - A = 29.85 -> 30.10 => (...)

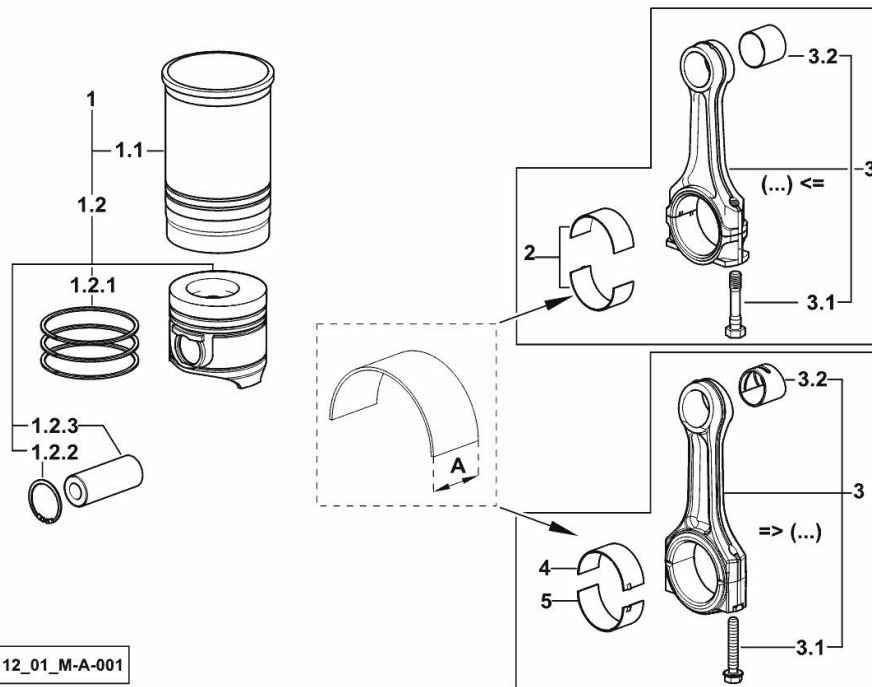

19\_N8112\_01\_M-A-001

**CAMSHAFT**

Fig.	P/n	QTY	Name
------	-----	-----	------

**Notes:**

[SAME 50]

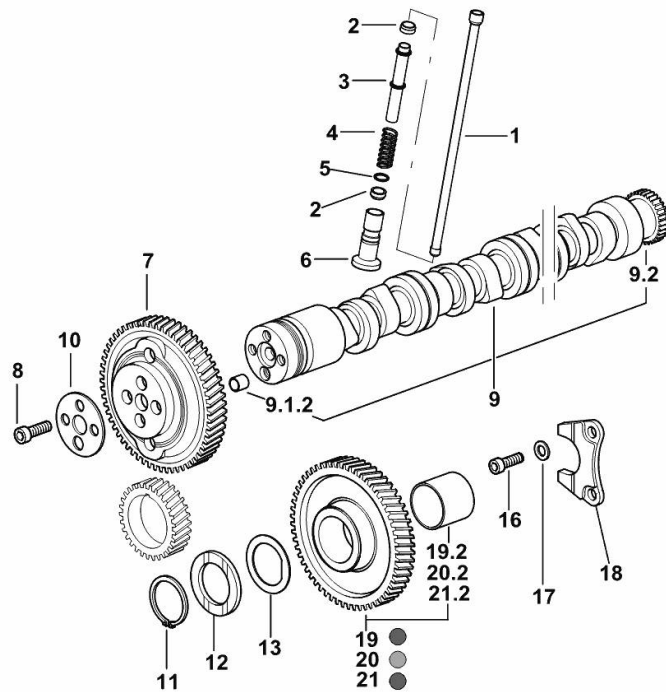

19\_N8113\_00\_0-A-002

1	0.065.1331.2	6	rod
2	2.1569.114.0/10	12	gasket 14x18.5x8
3	0.065.1332.0	6	sleeve
4	2.4019.300.1/10	6	spring 18.5x52x2
5	2.1599.437.0	6	shoulder ring
6	0.065.1330.0	6	tappets
7	0.013.5017.0	1	gear z=58
8	2.0132.207.2	4	screw m 10 p.1 x 25
9	0.012.8270.4	1	camshaft
9.1.2	2.1559.398.0	1	bushing 10.5x13x12
9.2	0.065.1324.0/10	1	gear Z = 32
10	0.065.1350.0	1	small disc
11	2.1410.016.1	1	circlip 40
12	0.065.1352.0	1	shim
13	0.018.2233.0	2	shoulder ring
16	2.0312.205.2	2	screw
17	2.1480.014.1	2	washer 8
18	0.065.1353.0	1	small plate
19	0.007.1177.3/20	0.1	gear z = 57 - WITH RED IDENTIFICATION STAMP
19.2	2.1559.185.0/10	1	bushing
20	0.007.1178.3/20	0.1	gear z = 57 - WITH YELLOW IDENTIFICATION STAMP
20.2	2.1559.185.0/10	1	bushing
21	0.007.1179.3/20	0.8	gear z = 57 - WITH GREEN IDENTIFICATION STAMP
21.2	2.1559.185.0/10	1	bushing

**TIMING CASE**

Fig.	P/n	QTY	Name
------	-----	-----	------

**Notes:**

[SAME 50]

5	2.0432.003.7	11	stud bolt m 8 p.1.25 / p.1 x 20
16	2.0312.214.2	7	screw m 8 p.1.25 x 40
17	2.1480.014.1	15	washer 8
18	0.013.4981.0	1	guard
19	0.065.1150.0/30	1	gasket
20	2.1470.004.2	2	lock washer 8
21	2.1011.405.2	2	nut m 8 p.1
22	2.0312.208.2	8	screw m 8 p.1.25 x 25
23	2.1529.167.0	1	oil seal

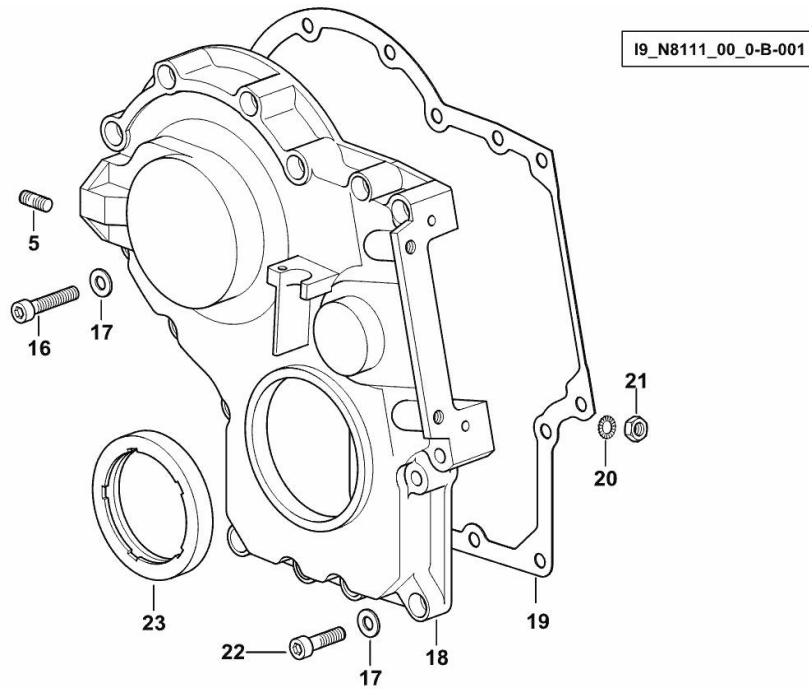

Section: B0 - ENGINE  
**CYLINDER HEAD**

Fig.	P/n	QTY	Name
------	-----	-----	------

Notes:

[SAME 50]

1	2.0399.130.2/10	3	screw m 8x36x44
2	2.1569.170.0/10	3	gasket 8.2 x 14
3	0.016.0291.0	3	small cap
4	0.069.1450.0/30	1	tappet gasket
7	2.1011.421.2	6	nut m 10 p.1.25
9.2	0.021.1434.0	2	screw
9.10.3	2.1011.405.2	2	nut m 8 p.1
9.10.4	0.066.1432.3	2	rocker arm
9.10.4.2	2.1559.021.0/40	1	bushing 15x19x22
9.10.5	2.1410.055.7	2	circlip 19
9.10.6.1	0.066.1431.0	1	pin
9.10.6.2	0.066.1430.0/10	1	support
9.10.7	2.1599.432.0	2	shoulder ring
16	2.1530.051.0	3	oil seal 20.22x3.53
17	0.012.2673.0	12	screw m 14 p.2x141
18.1	0.014.8945.3/10	1	head
18.1.2	0.014.8942.0	1	valve seat mm 45.118
18.1.3	0.014.8941.0	1	valve seat mm 40.653
18.1.4	0.007.1779.0/20	2	valve guide
18.1.5	0.010.6041.0/10	1	bush
18.1.6	2.3170.012.2	2	expansion plug Ø 30
18.2	0.066.1421.0	1	exhaust valve
18.3	0.010.6016.0	1	inlet valve mm 43.63 / Ø mm 9
18.4	0.066.1425.0	2	cup
18.5	0.074.1423.0	4	conical valve cotter
18.6	2.4019.287.0	2	spring
18.7	2.1519.117.0	2	special oil seal
18.8	2.0432.161.7	1	stud bolt m 10 p.1.5 / p.1.25 x 40
18.9	2.0432.163.7	2	stud bolt m 10 p.1.5 / p.1.25 x 45
20	2.0432.011.7	3	stud bolt m 8 p.1.25 / p.1 x 40
21	2.0432.005.7	3	stud bolt m 8 p.1.5 / p.1 x 25
25	0.014.5260.0/10	0.5	gasket - A - mm 1.4
26	0.014.5259.0/10	2	gasket - B - mm 1.2
27	0.014.5261.0/10	0.5	gasket - C - mm 1.6

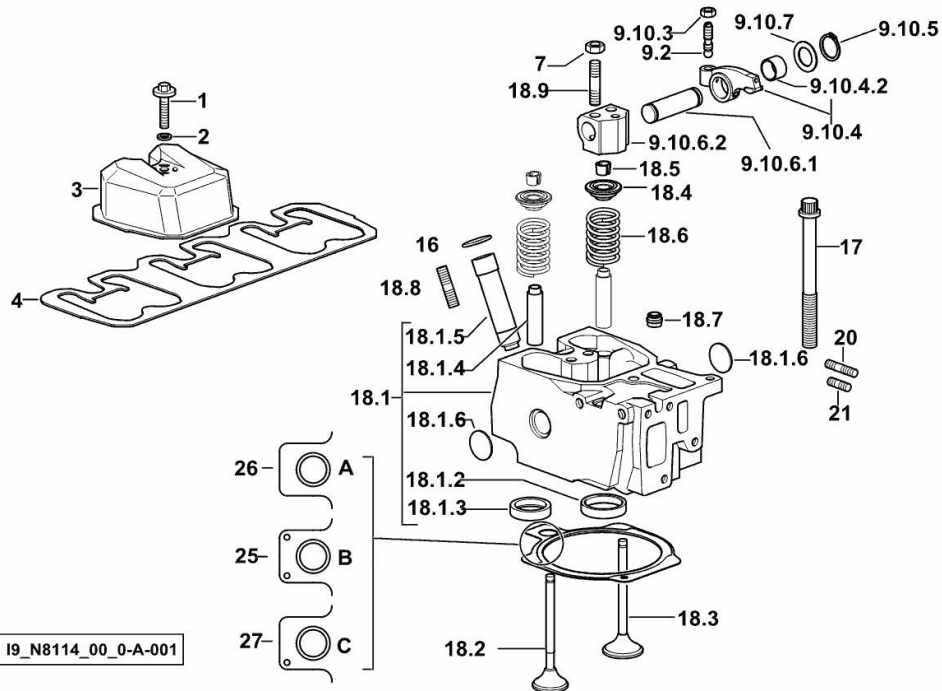

19\_N8114\_00\_0-A-001

Section: B0 - ENGINE  
**ENGINE OIL PUMP**

Fig.	P/n	QTY	Name
------	-----	-----	------

Notes:  
 [SAME 50]

35	0.065.1560.0/30	2	gasket
36	2.0169.005.2	2	screw m 6 p.1 x 12
37	2.1652.711.0	2	cylindrical plug 8x25
38	0.075.1551.4/30	1	support
38.1	0.075.1551.3/40	1	support
38.1.2	2.1559.186.0	1	special bushing 26 x 31.5 x 35
38.2	2.1219.025.2/10	1	ring nut m 36 p.1.5
38.3	2.1410.057.1	1	circlip 15
38.4	2.1589.153.0	1	shoulder ring 15.2 x 19 x 1.00
38.5	2.1589.146.0	2	shoulder ring 15.2 x 19 x 0.15
38.6	2.1589.147.0	2	shoulder ring 15.2 x 19 x 0.10
38.7	2.2020.001.0	1	ball bearing 15 x 32 x 8.00
38.8	2.1589.148.0	1	shoulder ring 28.2 x 31.8 x 0.5
38.9	2.1589.150.0	2	shoulder ring 28.2 x 31.8 x 0.1
38.10	2.1589.151.0	2	shoulder ring 28.2 x 31.8 x 0.15
38.11.1	0.065.1558.6/10	1	bevel drive
38.11.2	0.065.1559.0	1	bush
38.12	2.2680.020.0	1	ring 12 x 15 x 12
38.13	2.2725.016.0	1	roller cage 15 x 21 x 12
38.14	2.0342.007.2	1	screw m 4 p.0.7x25
38.15	2.0399.128.2/10	1	screw m 8 p.1 x 8
38.16	2.2030.002.0	1	ball bearing 12 x 28 x 8
40	0.065.1569.0/40	1	shaft
41	0.065.1562.0/10	1	joint
42	0.014.7994.4	1	oil pump
43	2.1470.006.2	2	lock washer 10
44	2.0112.323.2	2	screw m 10 p.1.5x70

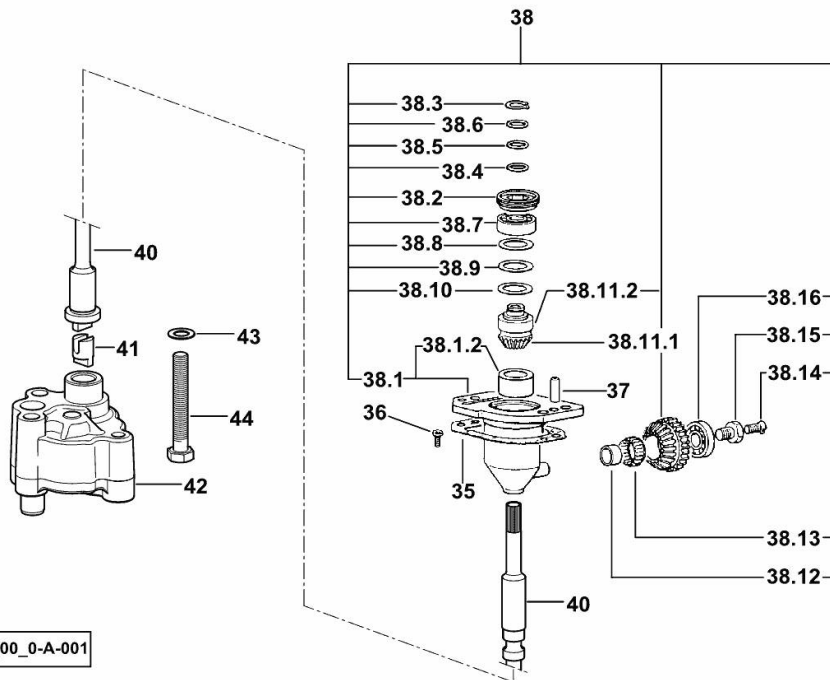

19\_38515\_00\_0-A-001

**LUBRICATION**

Fig.	P/n	QTY	Name
------	-----	-----	------

Notes:  
[SAME 50]

1	0.065.1160.3/20	3	valve
50	2.1099.108.2	3	special nut m 10 p.1
51	2.1560.006.0	12	gasket 10.2 x 16
52	0.086.1550.2	3	sprayer nozzle
55	2.0312.221.2	2	screw m 8 p.1.25x75
56	2.1480.014.1	2	washer 8
57	0.012.0688.4	1	sediment bowl
57.1	0.066.1553.0	1	cover
57.2	0.066.1554.0/20	1	gasket
57.3	2.0399.304.2	4	screw m 4 x 10
57.4.1	0.066.1555.0	1	tube
57.4.2	0.012.0688.0	1	small tank
58	2.1532.012.0	1	oil seal 6.75 x 1.78
59	2.1539.072.0	2	special oil seal 23.52 x 1.78
60	0.066.1558.0	1	bush
61	0.066.1557.2	1	tube
62	2.3350.003.1	1	nosepiece 8
63	2.3339.418.1	1	pipe fitting m 12 p.1
65	0.007.1427.0	1	tube
66	0.002.8816.0	1	small plate
67	2.0112.007.2	1	screw m 6 p.1 x 20
68	2.1011.103.2	1	nut m 6 p.1
69	2.1470.002.2	1	lock washer 6

19\_38515\_00\_0-C-001

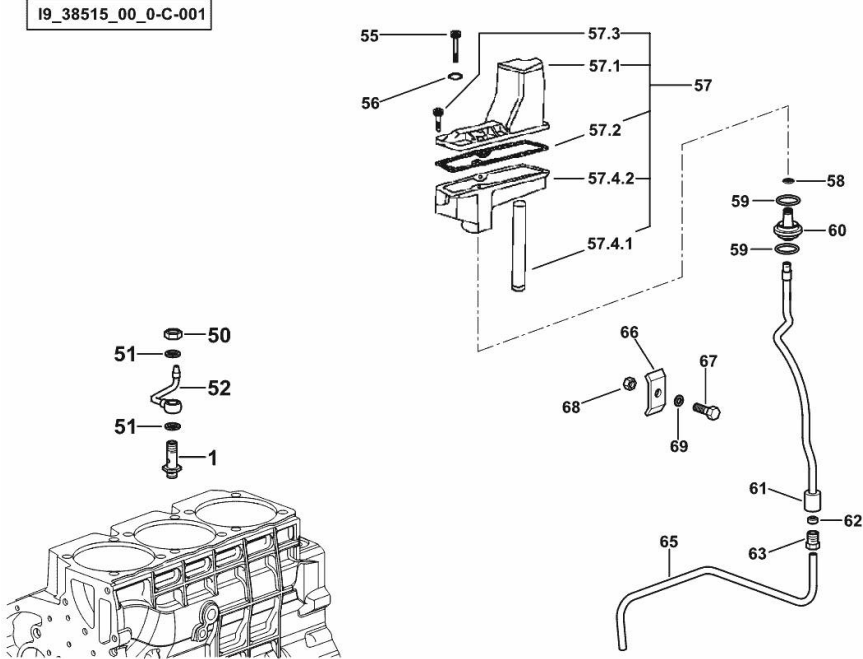

**LUBRICATION**

Fig.	P/n	QTY	Name
------	-----	-----	------

**Notes:**

[SAME 50]

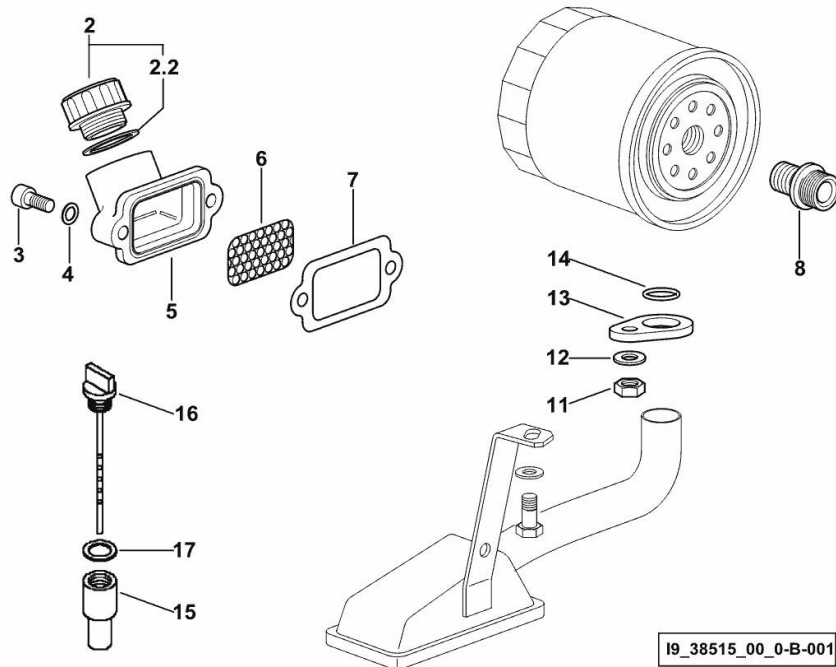

2	0.041.1135.4	1	plug 1" gas
2.2	2.1569.072.0	1	gasket 32 x 39.5 x 2
3	2.0312.205.2	2	screw
4	2.1480.014.1	2	washer 8
5	0.012.0613.0	1	pipe union
6	0.065.1567.0/10	1	filter
7	0.065.1566.0	1	gasket
8	2.3339.307.0	1	pipe fitting m 22 p.1.5-3/4"
11	2.1011.105.2	1	nut m 8 p.1.25
12	2.1470.004.2	1	lock washer 8
13	0.065.1538.0	1	flange
14	2.1539.040.0	1	special oil seal 21.82 x 3.53
15	0.012.0684.0	1	none
16	0.012.0682.2	1	dipstick
17	2.1539.065.0	1	special oil seal 8.73 x 1.78



**LUBRICANT OIL SUCTION PIPE**

Fig.	P/n	QTY	Name
------	-----	-----	------

Notes:  
[SAME 50]

83	2.1470.004.2	1	lock washer 8
84	2.0112.205.2	1	screw m 8 p.1.25 x 16
85	0.007.1425.3/10	1	tube

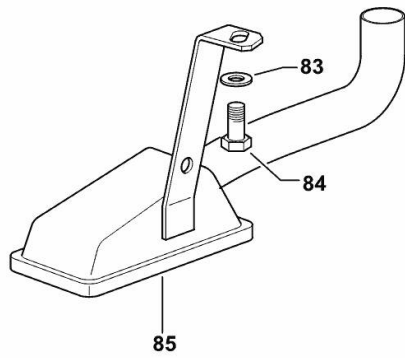

19\_38515\_06\_0-A-001

**SEDIMENTER BOWL BREATHER PIPE**

---

Fig.	P/n	QTY	Name
------	-----	-----	------

---

Notes:  
[SAME 50]

14	0.066.1559.0	1	tube
16	2.6859.073.2	1	clamp

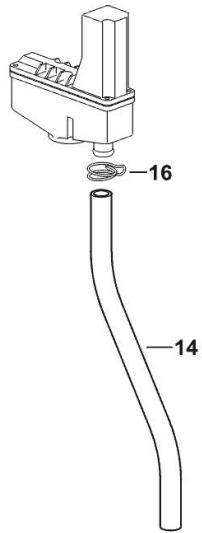

I9\_38519\_11\_0-C-001

**PIPE FOR OIL PRESSURE SENSOR**

Fig.	P/n	QTY	Name
------	-----	-----	------

**Notes:**

[SAME 50]

2	0.010.4868.3	1	tube
3	2.3249.014.2	1	pipe fitting m 12 p.1.5
4	2.3339.746.2	1	pipe union
5	2.0432.013.7	1	stud bolt m 8 p.1.25 / p.1 x 45
6	2.1560.008.0	3	gasket 12.2 x 18

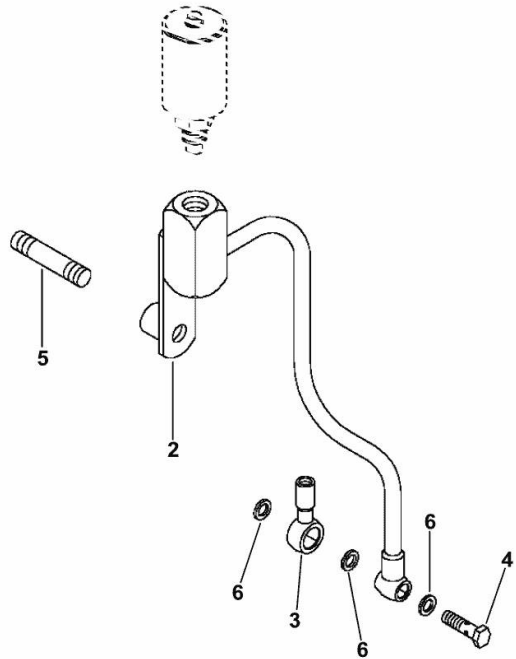

I9\_38515\_03\_0-B-001

**FUEL SETTLING FILTER VENT HOSE BRACKET**

Fig.	P/n	QTY	Name
------	-----	-----	------

Notes:  
[SAME 50]

2	0.075.1151.0	1	bracket
---	--------------	---	---------

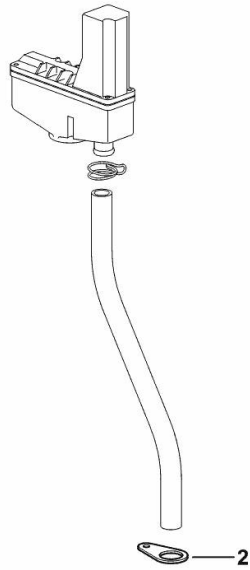

I9\_N8019\_12\_0-B-001

Thank you so much for reading.  
Please click the “Buy Now!”  
button below to download the  
complete manual.



After you pay.

You can download the most  
perfect and complete manual in  
the world immediately.

Our support email:

[ebooklibonline@outlook.com](mailto:ebooklibonline@outlook.com)