

CRANKCASE

Fig.	P/n	QTY	Name
------	-----	-----	------

Notes:

[5090 D 2WD -> ZKDBC60100TD30001] [5090 D 4WD -> ZKDBC60200TD30001]

19_K7711_00_0-A-001

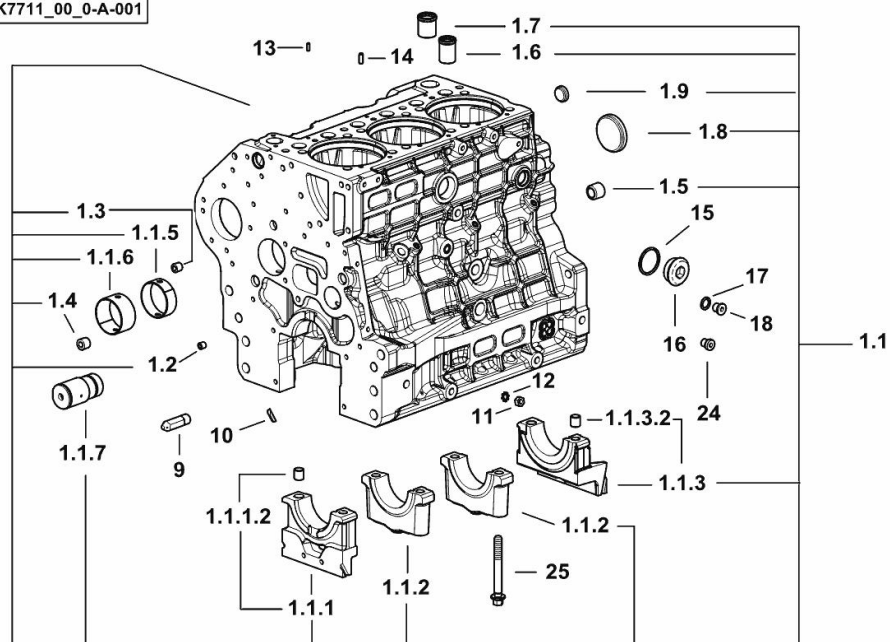

1.1	0.020.4331.3/20	1	crankcase
1.1.1	0.019.5106.3	1	support
1.1.1.2	2.1699.165.0	1	bush 12.3x15x16
1.1.2	0.019.5107.7	2	support
1.1.3	0.019.5108.3	1	support
1.1.3.2	2.1699.165.0	1	bush 12.3x15x16
1.1.5	0.065.1140.0	3	special bushing 59X55X20
1.1.6	0.065.1141.0	1	special bushing 59X55X30
1.1.7	0.019.4412.0	1	pin
1.2	2.3130.001.7	12	plug
1.3	2.3130.002.7	2	plug 1/4" gas
1.4	2.3130.003.7	4	plug 3/8" gas
1.5	2.3130.005.7	3	plug
1.6	0.019.4146.0	1	tube
1.7	0.019.6173.0	1	tube
1.8	2.3179.012.0	1	plug 60
1.9	2.3171.010.4	5	plug 25
9	0.019.4415.0/10	1	tube
10	0.066.1152.0/10	4	gasket
11	2.1011.405.2	2	nut m 8 p.1
12	2.1470.004.2	4	lock washer 8
13	2.1651.305.0	3	pin 4 x 12
14	2.1651.507.0	3	pin 6 x 16
15	2.1560.027.0	1	copper gasket 38.3x44
16	2.3139.031.2	1	plug
17	2.1560.010.0	1	gasket 14.2 x 20
18	2.3199.292.0	1	plug 1/4" gas
24	2.3139.024.2	1	plug m 12 p.1.5 (-> 30001)
25	2.0399.367.7	8	screw

CYLINDER LINER O-RING

Fig.	P/n	QTY	Name
------	-----	-----	------

Notes:

[5090 D 2WD -> ZKDBC60100TD30001] [5090 D 4WD -> ZKDBC60200TD30001]

16	2.1539.259.0	6	special oil seal 107.62x2.62
----	--------------	---	------------------------------

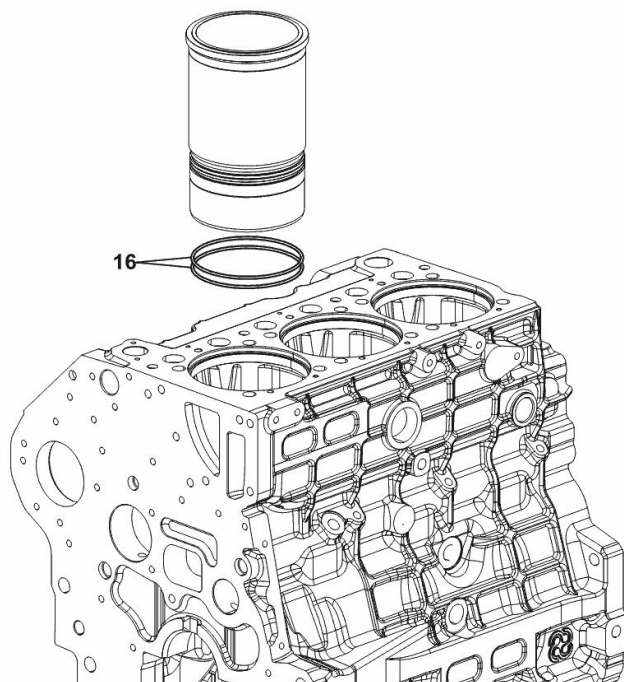

I9_K7712_00_0-B-001

MONOBLOC ENGINE-GEARBOX CONNECTING FLANGE

Fig.	P/n	QTY	Name
------	-----	-----	------

Notes:

[5090 D 2WD -> ZKDBC60100TD30001] [5090 D 4WD -> ZKDBC60200TD30001]

1	0.007.7752.0/30	1	flange
2	2.0112.511.2	8	screw m 14 p.2 x 30
3	2.1651.912.0	2	cylindrical plug 12x28
4	2.1651.917.0	1	cylindrical plug 12x40
5	2.0432.257.7	1	stud bolt m 12 p.1.75 - 1.25 x 30
6	2.0439.250.7	1	stud bolt m 12 / m 10 x 30
7	0.011.9294.0/10	1	bush

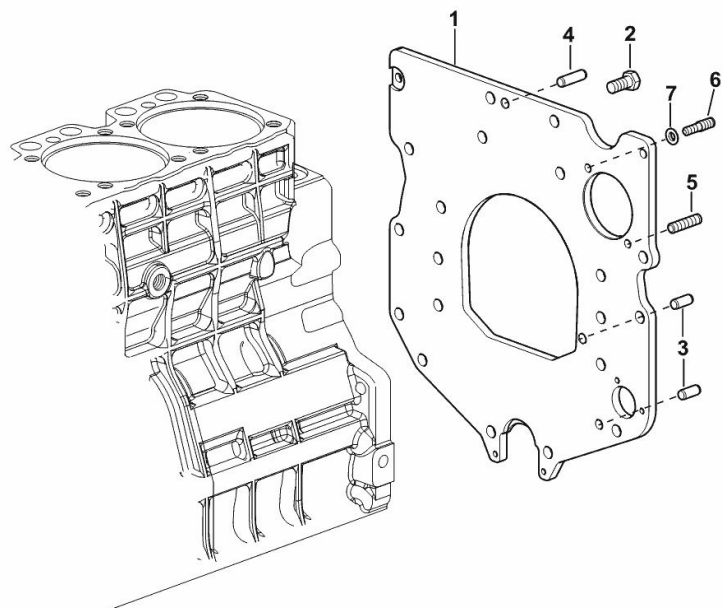

19_N8911_01_0-A-001

SIDE PLUG FOR CYLINDER BLOCK

Fig.	P/n	QTY	Name
------	-----	-----	------

Notes:

[5090 D 2WD -> ZKDBC60100TD30001] [5090 D 4WD -> ZKDBC60200TD30001]

12	2.1560.018.0	1	gasket 22.2 x 29
13	2.3120.102.0	1	plug

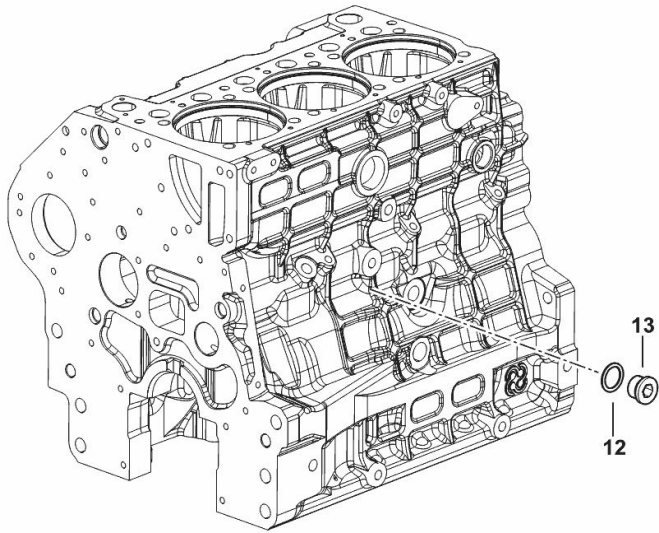

19_K7815_03_0-B-001

FITTING FOR ENGINE OIL PRESSURE SWITCH

Fig.	P/n	QTY	Name
------	-----	-----	------

Notes:

[5090 D 2WD -> ZKDBC60100TD30001] [5090 D 4WD -> ZKDBC60200TD30001]

1	2.3120.101.0	1	plug m 18 p.1.5
2	2.1560.014.0	1	washer 18.2 x 24
3	2.3249.697.2	1	pipe union
4	2.1560.008.0	3	gasket 12.2 x 18
5	2.3249.014.2	1	pipe fitting m 12 p.1.5

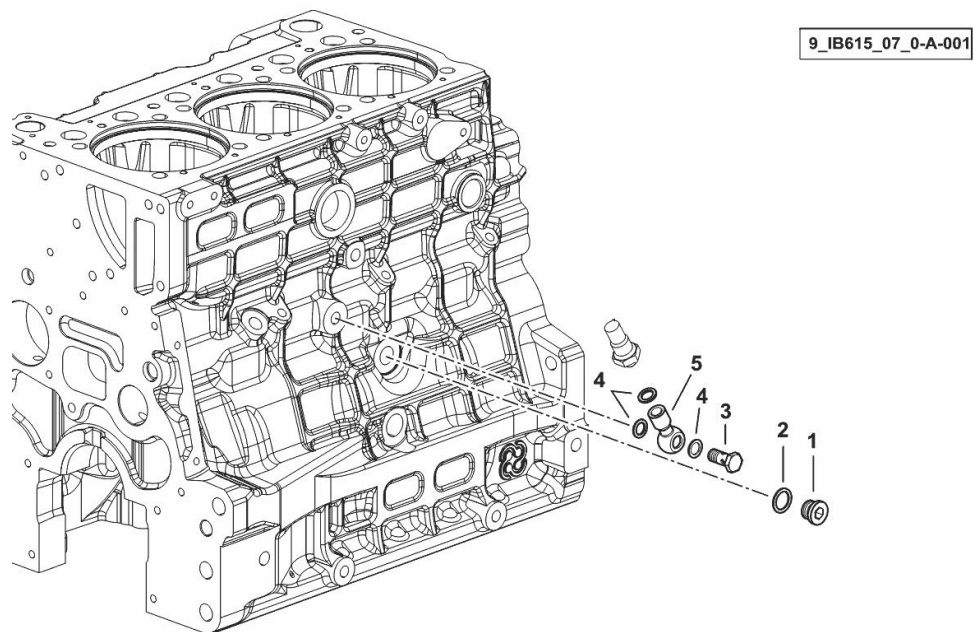

CRANKSHAFT

Fig.	P/n	QTY	Name
------	-----	-----	------

Notes:

[5090 D 2WD -> ZKDBC60100TD30001] [5090 D 4WD -> ZKDBC60200TD30001]

1	0.019.2255.3/20	1	crankshaft
1.2	0.007.0855.0/10	1	gear
1.3	2.1651.915.0	1	pin 12x35
7	0.019.5455.0	4	main half bushing STANDARD
8	0.019.5456.0	4	main half bushing STANDARD
9	2.1599.524.7	1	washer 21x60x12
10	0.065.1218.0	4	shim STANDARD
11	2.1529.073.0	1	special oil seal 110x130x13
12	0.065.1254.0/20	1	gasket
13	0.007.0851.0/10	1	cover
14	2.1475.002.7	9	washer 8.4
15	2.0112.207.2	7	screw m 8 p 1.25 x 20
20	2.0432.003.7	2	stud bolt m 8 p.1.25 / p.1 x 20
21	2.1011.405.2	2	nut m 8 p.1
1001	0.065.1218.7		shim + mm 0.10
1002	0.065.1218.8		shim + mm 0.15

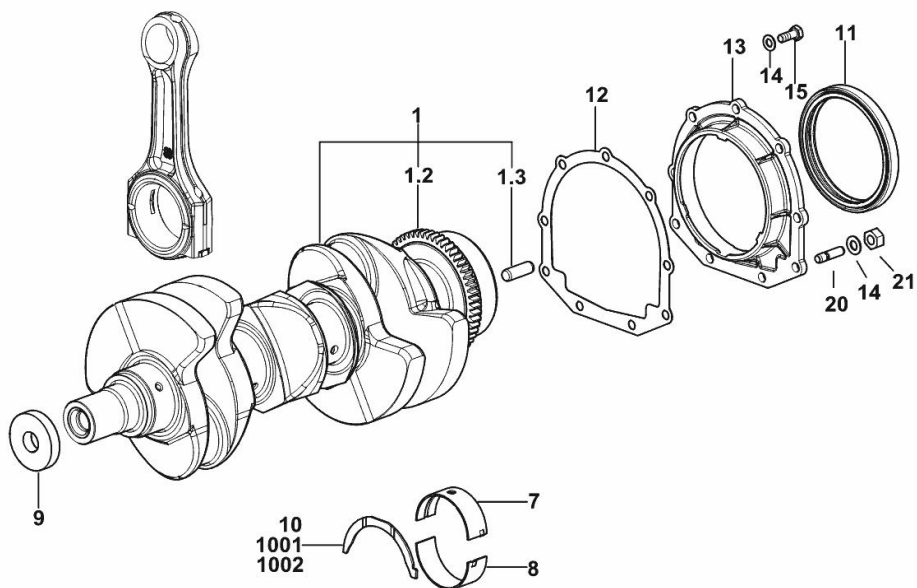

I9_K7712_00_0-A-001

CRANKSHAFT GEAR

Fig.	P/n	QTY	Name
------	-----	-----	------

Notes:

[5090 D 2WD -> ZKDBC60100TD30001] [5090 D 4WD -> ZKDBC60200TD30001]

1	0.019.4145.0	1	gear z = 33
2	2.1720.006.0	1	key 4x6.5

I9_K7713_00_0-D-001

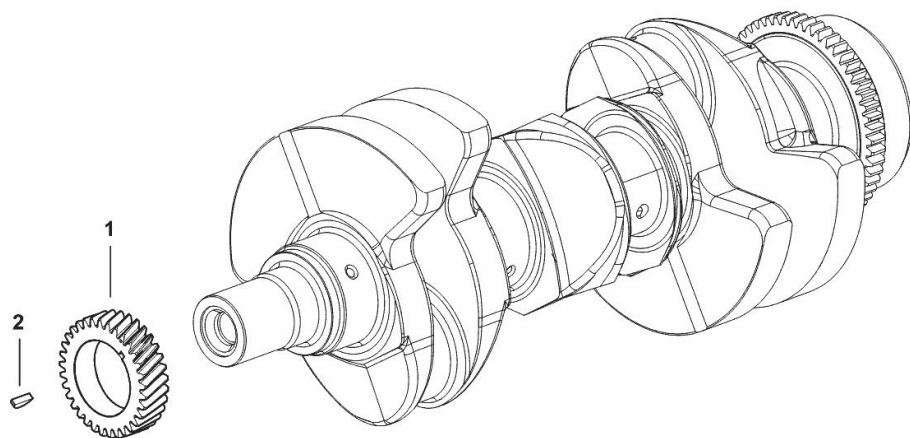

CRANKSHAFT PULLEY

Fig.	P/n	QTY	Name
------	-----	-----	------

Notes:

[5090 D 2WD -> ZKDBC60100TD30001] [5090 D 4WD -> ZKDBC60200TD30001]

1	0.019.9925.0	1	pulley
2	0.019.6668.0	1	flange
3	0.065.1256.0	2	ring 45x52
4	2.1579.865.0	1	spacer 45.2x51.8x10
5	2.0439.195.7	1	stud bolt m 20 p.1.5x80
6	2.1019.094.7	1	nut m 20 p.1.5
7	2.0112.320.2	6	screw m 10 p.1.5 x 55
8	2.1470.006.2	6	lock washer 10
9	2.1720.006.0	1	key 4x6.5
10	0.019.6413.0	1	gear wheel
11	2.1651.505.0	1	cylindrical plug 6x12

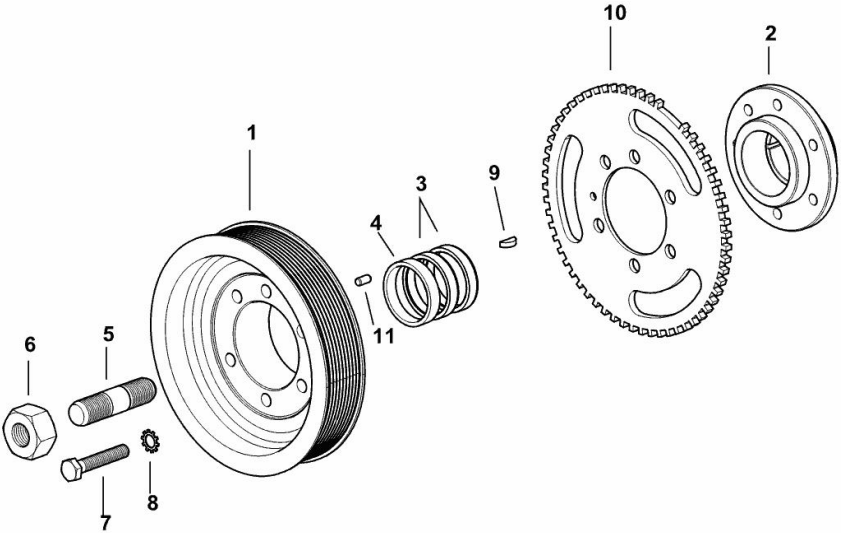

19_K7812_01_0-A-001

CRANKSHAFT - FLYWHEEL

Fig.	P/n	QTY	Name
------	-----	-----	------

Notes:

[5090 D 2WD -> ZKDBC60100TD30001] [5090 D 4WD -> ZKDBC60200TD30001]

1	0.011.2162.3/10	1	flywheel
1.2	0.069.1242.0	1	crown wheel Z = 121
2	0.255.2525.0/10	1	flange
3	2.0399.371.0	6	screw

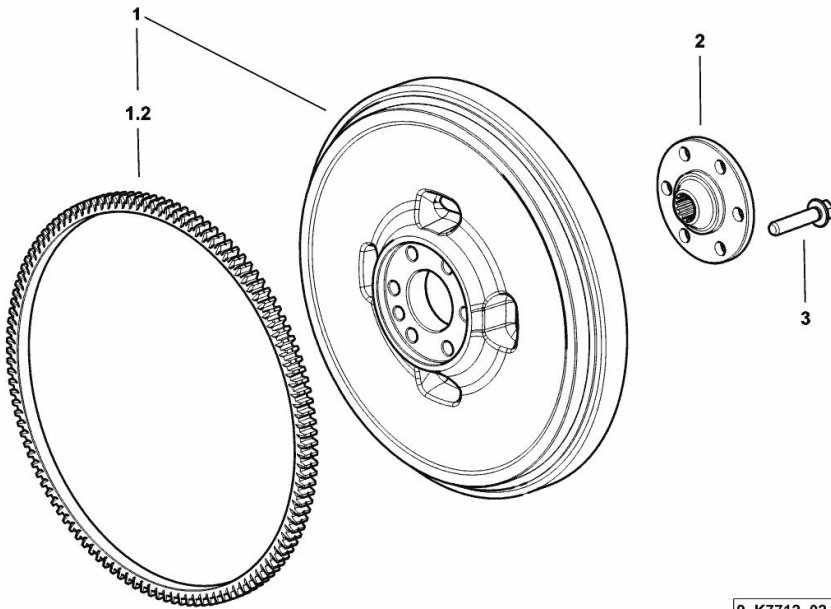

9_K7712_02_0-A-001

CRANKSHAFT - FLYWHEEL

Fig.	P/n	QTY	Name
------	-----	-----	------

Notes:

[5090 D 2WD -> ZKDBC60100TD30001] [5090 D 4WD -> ZKDBC60200TD30001]

1	0.014.2774.3	1	flywheel
1.2	0.069.1242.0	1	crown wheel Z = 121
2	2.0399.368.0	6	screw

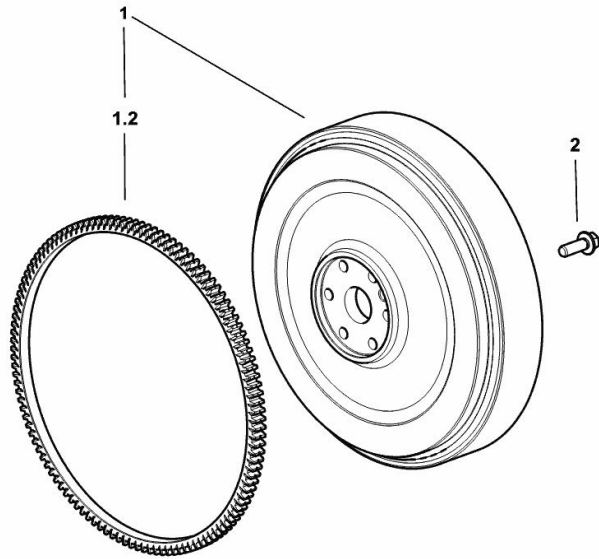

9_K7712_03_0-A-001

Buy Now



Our support email:

ebooklibonline@outlook.com