

OIL COOLER PIPE

Fig.	P/n	QTY	Name
------	-----	-----	------

Notes:

[5100 C -> ZKDY480200TD10001]

1	0.020.7682.3	1	tube
2	0.020.7684.3	1	tube
3	2.3249.460.2	2	pipe fitting m 22 p.1.5 - 7/8
4	0.020.7686.3	1	tube
5	0.020.7685.3	1	tube
6	0.019.1193.3	1	channel
7	2.3121.008.2	1	plug
9	2.3320.321.0	1	terminal Ø 20/20
10	0.019.1197.0	2	bracket
11	2.1310.004.2	2	flat washer 8.4x17
12	2.0112.207.2	1	screw m 8 p 1.25 x 20
13	2.1310.002.2	4	flat washer 6.4x12.5
14	2.0112.004.2	2	screw m 6 p.1 x 14
15	2.0112.220.2	1	screw m 8 p.1.25x55
16	2.1011.103.2	2	nut m 6 p.1
17	2.1560.010.0	1	gasket 14.2 x 20
18	2.3120.009.4	1	plug m 14 p.1.5

9_Y5282_05_0-A-001

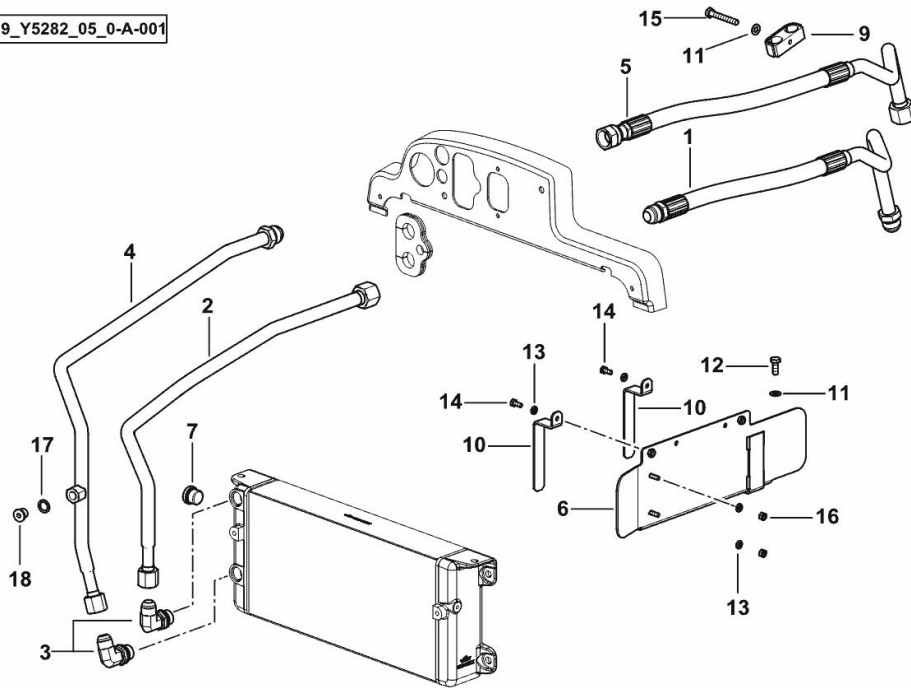

GEARBOX OIL HEAT EXCHANGER SYSTEM

9_Y5682_02_0-A-001

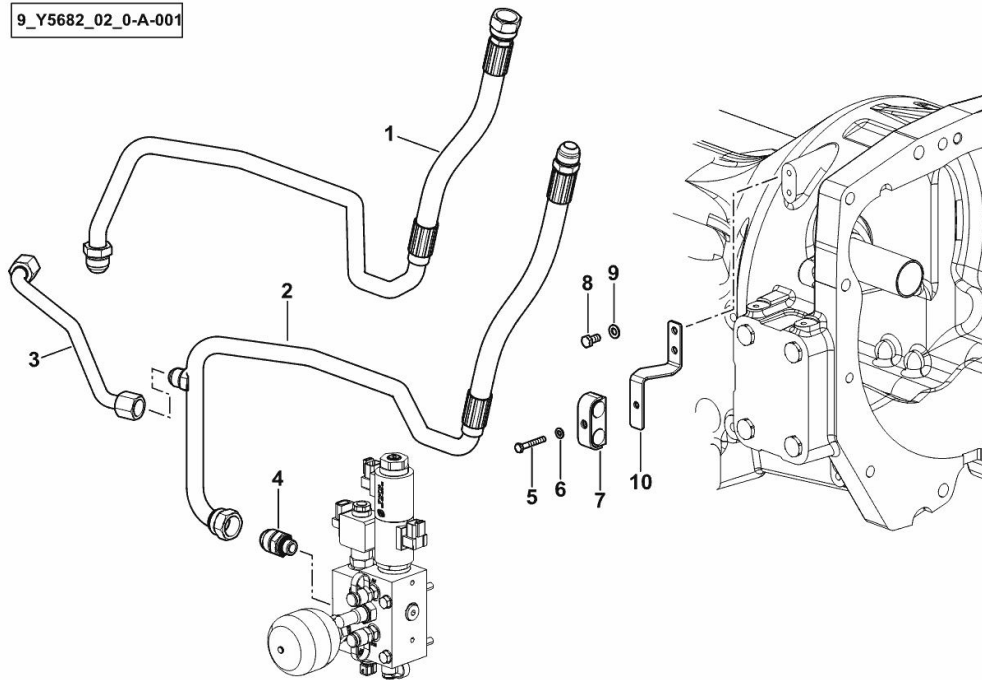

Fig.	P/n	QTY	Name
------	-----	-----	------

Notes:

[5100 C -> ZKDY480200TD10001]

1	0.020.7545.3	1	tube
2	0.020.7556.3	1	tube
3	0.020.8613.3	1	tube
4	2.3249.148.2	1	pipe fitting m 18 - 1/16" JIC
5	2.0112.015.2	1	screw m 6 p.1x40
6	2.1310.002.2	1	flat washer 6.4x12.5
7	2.3320.321.0	1	terminal Ø 20/20
8	2.0112.205.2	2	screw m 8 p.1.25 x 16
9	2.1310.004.2	2	flat washer 8.4x17
10	0.020.7558.3	1	bracket

HYDRAULIC PUMP 14 cc dx/rh/re

Fig.	P/n	QTY	Name
------	-----	-----	------

Notes:

[5100 C -> ZKDY480200TD10001]

1	2.4539.480.0/10	1	hydraulic pump 14 cc dx/rh/re - BOSCH ☞ 2.4539.480.0/10
2	2.1549.321.0	2	spacer 10.5X18X5
3	2.1474.010.2	2	washer 10
4	2.0112.331.2	2	screw m 10 p.1.5x110

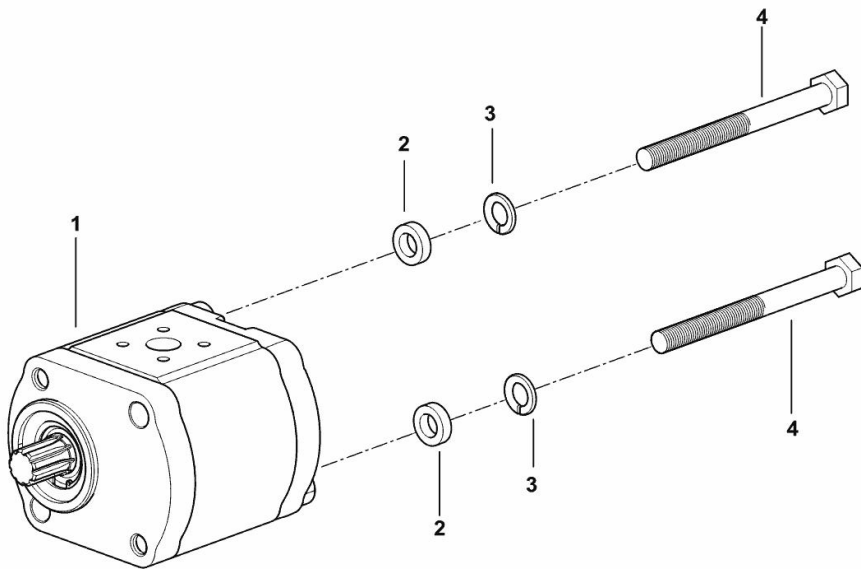

9_R8982_01_0-A-001

HYDRAULIC PUMP 16 cc - sx/lh/li

Fig.	P/n	QTY	Name
------	-----	-----	------

Notes:

[5100 C -> ZKDY480200TD10001]

1	2.4539.310.0/10	1	hydraulic pump 16cc sx/lh/li - BOSCH ☞ 2.4539.310.0/10
2	2.1474.010.2	2	washer 10
3	2.0312.327.2	2	screw m 10 p.1.5x110

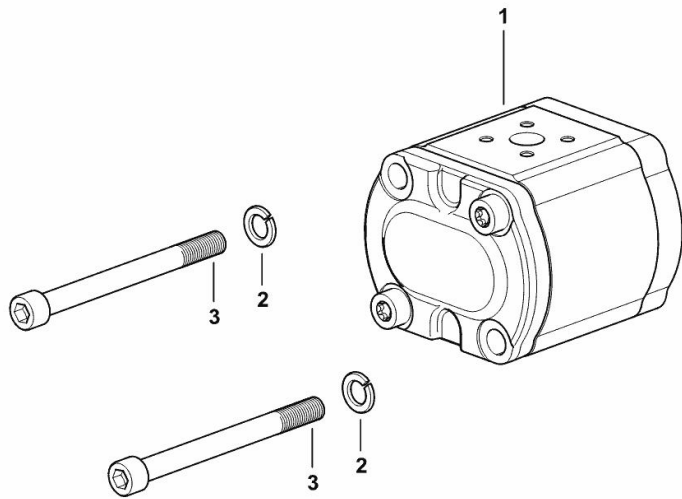

9_F0282_02_0-A-002

HYDRAULIC PUMP 22.5 cc - dx/rh/re

Fig.	P/n	QTY	Name
------	-----	-----	------

Notes:

[5100 C -> ZKDY480200TD10001]

1	2.4539.620.0/10	1	hydraulic pump 22.5 cc dx/rh/re - BOSCH - ☞ 2.4539.620.0/10
2	2.1480.015.2	2	washer 10
3	2.0169.019.2	2	screw m 10x135

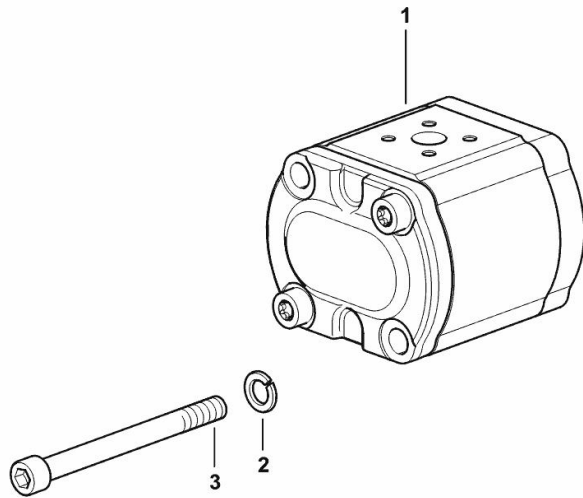

9_21082_01_0-A-001

REDUCE AND OLD VALVE

Fig.	P/n	QTY	Name
------	-----	-----	------

Notes:

[5100 C -> ZKDY480200TD10001]

1	0.015.0001.4/10	1	valve
1.2	0.015.0236.0	1	slider
1.3	2.4019.431.1/30	1	spring 6.9x11.3x2.2x64
1.4	2.1561.108.0	1	oil seal 16
1.5	2.3120.010.4	1	plug m 16 p.1.5
1.6	0.015.0028.0	2	slider
1.7	2.4019.770.1	1	spring
1.8	2.1539.250.0	1	ring 11.3x2.2
1.9	2.3139.021.2	1	plug m 14
1.10	2.1539.251.0	2	ring 15.3x2.2
1.11	2.3199.331.2	1	plug m 18
1.12	2.4019.428.1	1	spring 10.4x7.2x1.6
1.13	2.3199.330.2	1	plug m 18
1.14	2.1560.006.0	1	gasket 10.2 x 16
1.15	2.2810.002.0	1	ball mm 6.350
1.16	2.3199.252.2	1	plug m 10 p.1.5
1.17	2.1531.016.0	1	ring 8.74 x 1.78
2	2.3729.696.0	2	socket
3	2.1480.014.2	2	washer 8
4	2.0312.221.2	2	screw m 8 p.1.25x75

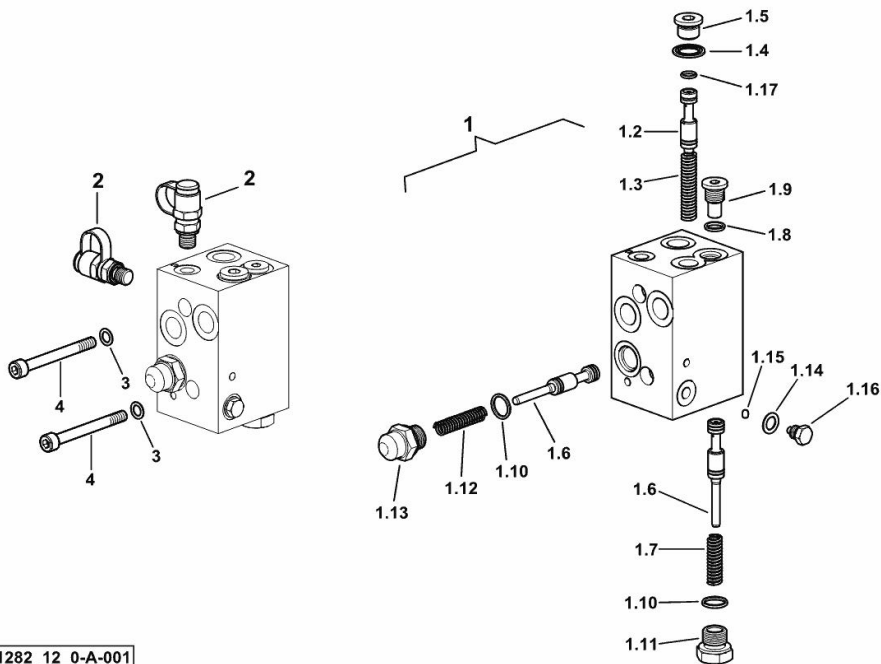

9_H1282_12_0-A-001

PRESSURE CONTROL VALVE AND HOLDING VALVE

Fig.	P/n	QTY	Name
------	-----	-----	------

Notes:

[5100 C -> ZKDY480200TD10001]

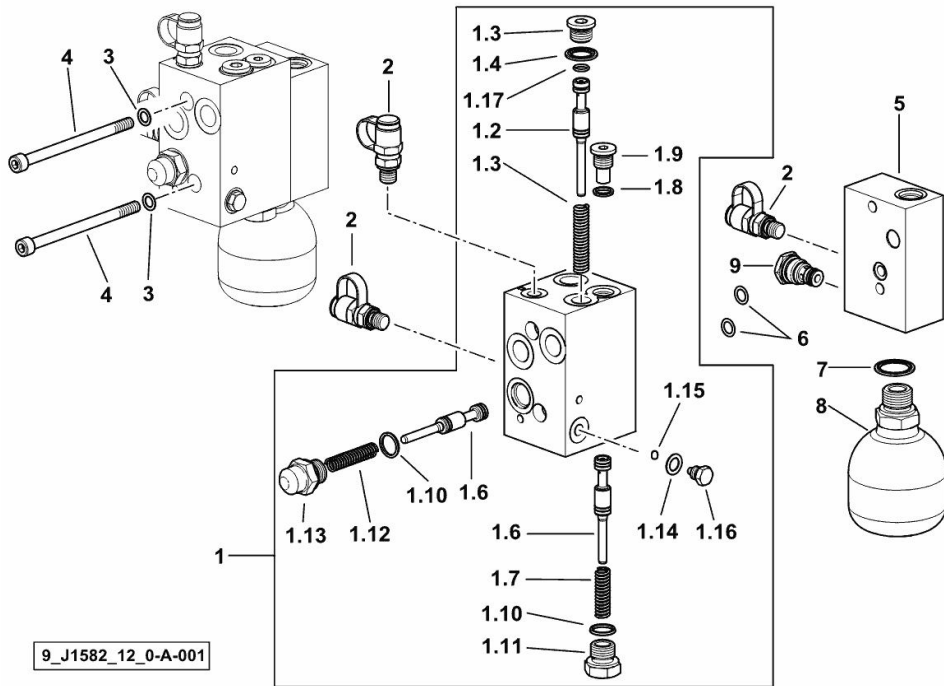

1	0.015.0001.4/10	1	valve
1.2	0.015.0236.0	1	slider
1.3	2.4019.431.1/30	1	spring 6.9x11.3x2.2x64
1.4	2.1561.108.0	1	oil seal 16
1.6	0.015.0028.0	2	slider
1.7	2.4019.770.1	1	spring
1.8	2.1539.250.0	1	ring 11.3x2.2
1.9	2.3139.021.2	1	plug m 14
1.10	2.1539.251.0	2	ring 15.3x2.2
1.11	2.3199.331.2	1	plug m 18
1.12	2.4019.428.1	1	spring 10.4x7.2x1.6
1.13	2.3199.330.2	1	plug m 18
1.14	2.1560.006.0	1	gasket 10.2 x 16
1.15	2.2810.002.0	1	ball mm 6.350
1.16	2.3199.252.2	1	plug m 10 p.1.5
1.17	2.1531.016.0	1	ring 8.74 x 1.78
2	2.3729.696.0	3	socket
3	2.1480.014.2	2	washer 8
4	2.0319.025.2	2	screw
5	0.015.6629.0/10	1	small block
6	2.1531.025.0	2	oil seal 10.82x1.78
7	2.1561.112.0	1	gasket Ø 22 -B-
8	0.013.8759.0/10	1	accumulator lt 0.16
9	2.3729.691.0	1	valve

9_J1582_12_0-A-001

OIL PRESSURE LINE FILTER

Fig.	P/n	QTY	Name
------	-----	-----	------

Notes:

[5100 C -> ZKDY480200TD10001]

1	2.4419.813.0	1	oil filter 9" ☞ 2.4419.813.0
---	--------------	---	---------------------------------

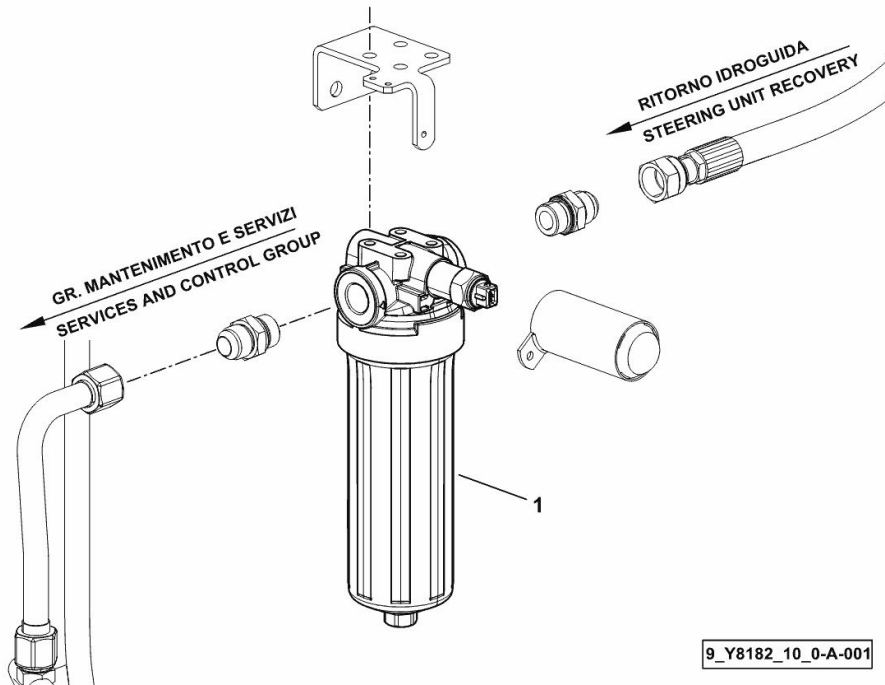

9_Y8182_10_0-A-001

PRESSURE REGULATION SYSTEM

Fig.	P/n	QTY	Name
------	-----	-----	------

Notes:

- FOR TYPES WITH HYDRAULIC PARK BRAKE [5100 C -> ZKDY480200TD10001]

9_Y5282_08_0-A-001

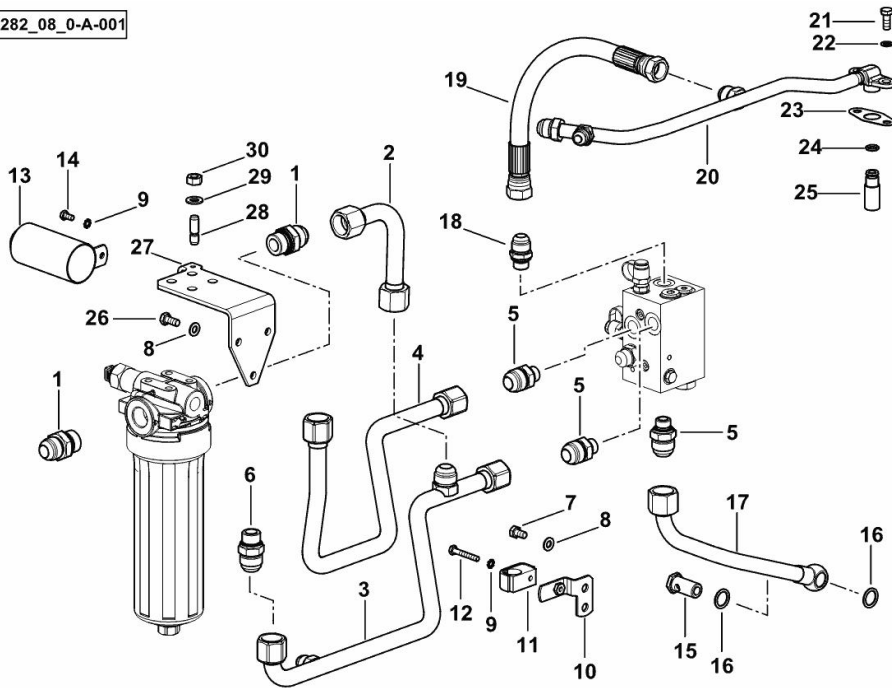

1	2.3249.100.2	2	pipe fitting M/M 1-16JIC-G3/4
2	0.020.4687.3	1	tube
3	0.015.6635.3/10	1	tube
4	0.015.6637.3	1	tube
5	2.3249.148.2	3	pipe fitting m 18 - 1/16" JIC
6	2.3249.158.2	1	pipe fitting
7	2.0112.204.2	2	screw m 8 p.1.25x14
8	2.1310.004.2	5	flat washer 8.4x17
9	2.1470.002.2	1	lock washer 6
10	0.015.2985.3	1	bracket
11	2.3320.111.0	1	terminal Ø 20
12	2.0112.015.2	1	screw m 6 p.1x40
13	0.019.4482.2	1	tube
14	2.0112.003.2	1	screw m 6 p.1 x 12
15	2.3339.295.2/10	1	pipe union m 18 p.1.5 x 35
16	2.1560.014.0	2	washer 18.2 x 24
17	0.015.6636.3	1	tube
18	2.3249.141.2	1	pipe fitting 7/8 JIC-M18
19	0.015.0404.3	1	tube
20	0.020.8688.3	1	tube
21	2.0112.207.2	2	screw m 8 p 1.25 x 20
22	2.1560.004.0	2	copper gasket 8.2 x 14
23	0.052.1558.0/10	1	gasket
24	2.1531.024.0	1	oil seal 10.77x2.62
25	0.008.3750.0	1	tube
26	2.0112.206.2	3	screw m 8 p.1.25 x 18
27	0.020.4815.0/10	1	bracket
28	2.0432.153.7	4	stud bolt m 10 p.1.5 / p.1.25 x 20
29	2.1310.006.2	4	flat washer 10.5x21
30	2.1011.421.2	4	nut m 10 p.1.25

PRESSURE REGULATION SYSTEM

9_Y4982_08_0-A-001

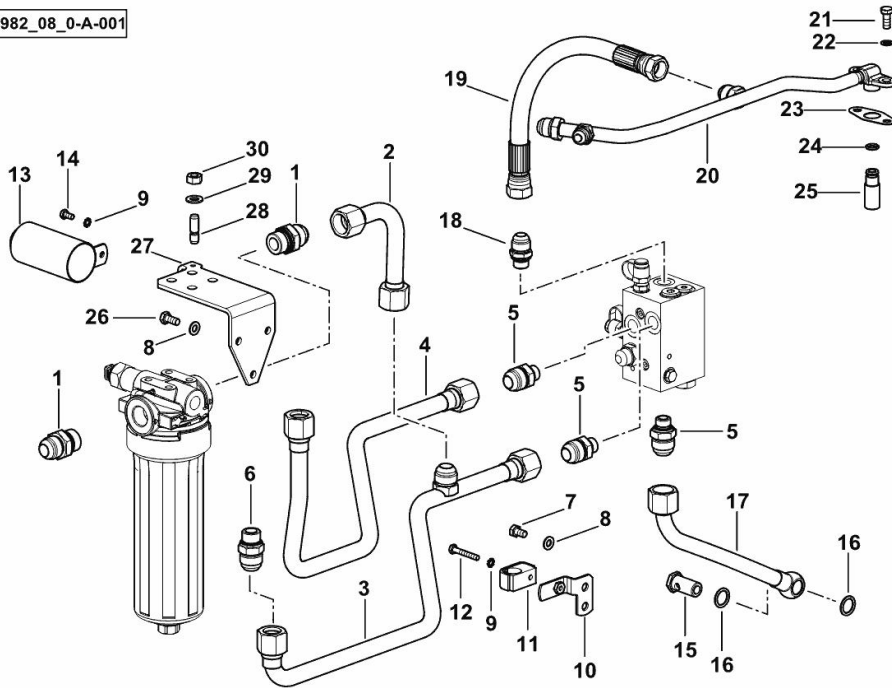

Fig.	P/n	QTY	Name
------	-----	-----	------

Notes:

[5100 C -> ZKDY480200TD10001]

1	2.3249.100.2	2	pipe fitting M/M 1-16JIC-G3/4
2	0.020.4687.3	1	tube
3	0.015.1363.3	1	tube
4	0.015.1365.3	1	tube
5	2.3249.148.2	3	pipe fitting m 18 - 1/16" JIC
6	2.3249.158.2	1	pipe fitting
7	2.0112.204.2	2	screw m 8 p.1.25x14
8	2.1310.004.2	5	flat washer 8.4x17
9	2.1470.002.2	1	lock washer 6
10	0.015.2985.3	1	bracket
11	2.3320.111.0	1	terminal Ø 20
12	2.0112.015.2	1	screw m 6 p.1x40
13	0.019.4482.2	1	tube
14	2.0112.003.2	1	screw m 6 p.1 x 12
15	2.3339.295.2/10	1	pipe union m 18 p.1.5 x 35
16	2.1560.014.0	2	washer 18.2 x 24
17	0.015.0405.3	1	tube
18	2.3249.141.2	1	pipe fitting 7/8 JIC-M18
19	0.015.0404.3	1	tube
20	0.020.8688.3	1	tube
21	2.0112.207.2	2	screw m 8 p 1.25 x 20
22	2.1560.004.0	2	copper gasket 8.2 x 14
23	0.052.1558.0/10	1	gasket
24	2.1531.024.0	1	oil seal 10.77x2.62
25	0.008.3750.0	1	tube
26	2.0112.206.2	3	screw m 8 p.1.25 x 18
27	0.020.4815.0/10	1	bracket
28	2.0432.153.7	4	stud bolt m 10 p.1.5 / p.1.25 x 20
29	2.1310.006.2	4	flat washer 10.5x21
30	2.1011.421.2	4	nut m 10 p.1.25

Buy Now



Our support email:

ebooklibonline@outlook.com