

COMPLEMENT FOR 10-WAY AUXILIARY HYDRAULIC CONTROL VALVE

Fig.	P/n	QTY	Name
------	-----	-----	------

Notes:
 [5120P -> ZKDBA602W0TD20001]

1	0.019.1147.3	1	tube
2	2.1561.112.0	4	gasket Ø 22 -B-
3	2.3339.581.2/20	2	pipe union m 22 p.1.5x45
4	2.3249.464.2	1	pipe fitting
5	0.019.1148.3	1	tube
6	0.019.1149.0	1	bracket
7	2.0112.203.2	2	screw m 8 p.1.25 x 12
8	2.1310.004.2	2	flat washer 8.4x17
9	2.1019.091.2	2	special nut m 30 p.1.5x8
10	0.010.8473.0	2	coupling FASTER - m 22 p.1.5 / Ø 38

☞ 0.010.8473.0

9_Y8888_46_0-A-001

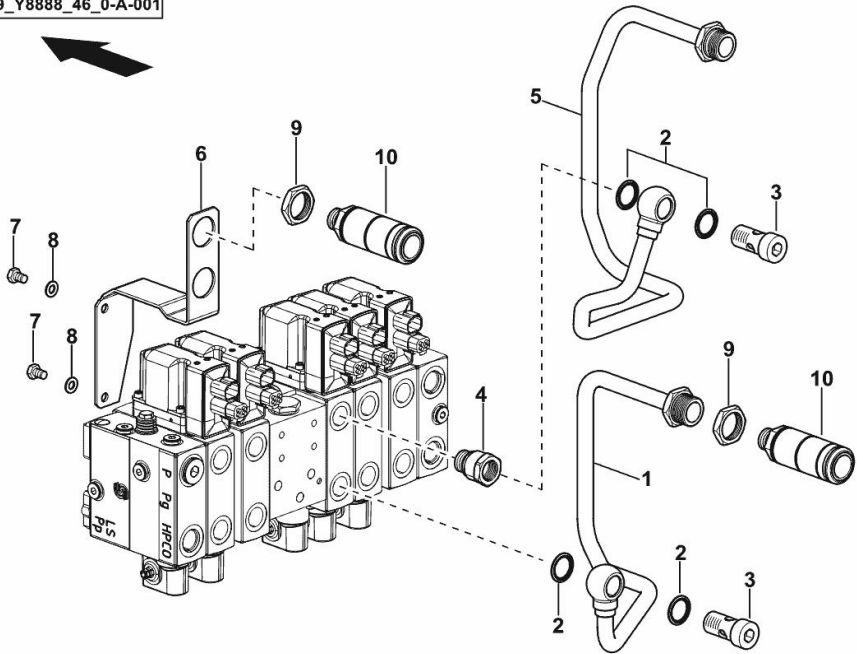

REAR QUICK ACTION COUPLERS - POWERBEYOND

Fig.	P/n	QTY	Name
------	-----	-----	------

Notes:
 - FOR TYPES WITH FRONT LOADER [5120P -> ZKDBA602W0TD20001]

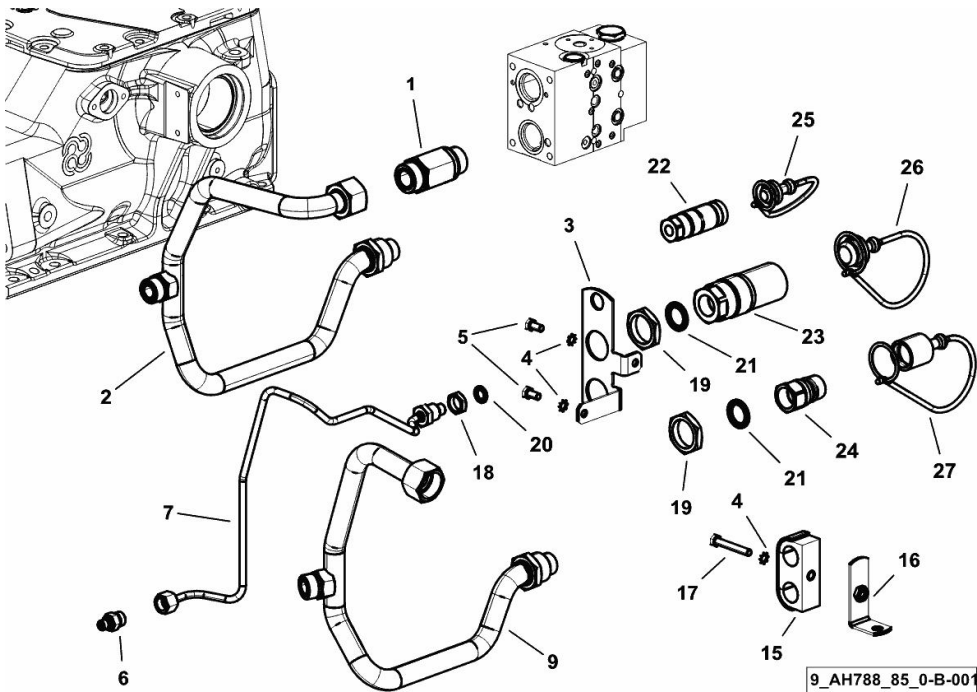

1	2.3249.448.2	1	pipe fitting
2	0.021.3523.3	1	tube
3	0.017.7066.0	1	bracket
4	2.1470.004.2	3	lock washer 8
5	2.0112.205.2	2	screw m 8 p.1.25 x 16
6	2.3272.005.0	1	pipe fitting m 12
7	0.021.3505.3	1	tube
9	0.021.3633.3	1	terminal
15	2.3329.004.0	1	terminal
16	0.017.9009.3	1	bracket
17	2.0112.220.2	1	screw m 8 p.1.25x55
18	2.1019.111.2	1	nut m 20 p.1.5
19	2.1019.146.2	2	nut m 36 p.2
20	2.1569.207.0	1	special oil seal G 1/4
21	2.1569.205.0	2	special oil seal G 3/4
22	2.3729.560.2	1	coupling 3/8
			☞ 2.3729.560.2
23	2.3729.570.2	1	coupling 3/4
			☞ 2.3729.570.2
24	2.3339.963.2	1	coupling 3/4
25	0.012.2605.0	1	plug 3/8 M
26	0.012.2603.0	1	plug 3/4 M
27	0.012.2604.0	1	plug 3/4 F

REAR QUICK ACTION COUPLERS - POWERBEYOND

Fig.	P/n	QTY	Name
------	-----	-----	------

Notes:

- FOR TYPES WITH SUSPENDED DRIVING AXLE [5120P -> ZKDBA602W0TD20001]

1	2.3249.448.2	1	pipe fitting
2	0.019.4274.3	1	tube
3	0.017.7066.0	1	bracket
4	2.1470.004.2	3	lock washer 8
5	2.0112.205.2	2	screw m 8 p.1.25 x 16
6	2.3335.006.2	1	pipe union m 14 p.1.5X26
7	0.019.6449.3	1	tube
8	2.1561.107.0	2	oil seal Ø 14 -B-
9	0.019.4277.3	1	tube
15	2.3329.004.0	1	terminal
16	0.017.9009.3	1	bracket
17	2.0112.220.2	1	screw m 8 p.1.25x55
18	2.1019.111.2	1	nut m 20 p.1.5
19	2.1019.146.2	2	nut m 36 p.2
20	2.1569.207.0	1	special oil seal G 1/4
21	2.1569.205.0	2	special oil seal G 3/4
22	2.3729.560.2	1	coupling 3/8 ☞ 2.3729.560.2
23	2.3729.570.2	1	coupling 3/4 ☞ 2.3729.570.2
24	2.3339.963.2	1	coupling 3/4
25	0.012.2605.0	1	plug 3/8 M
26	0.012.2603.0	1	plug 3/4 M
27	0.012.2604.0	1	plug 3/4 F

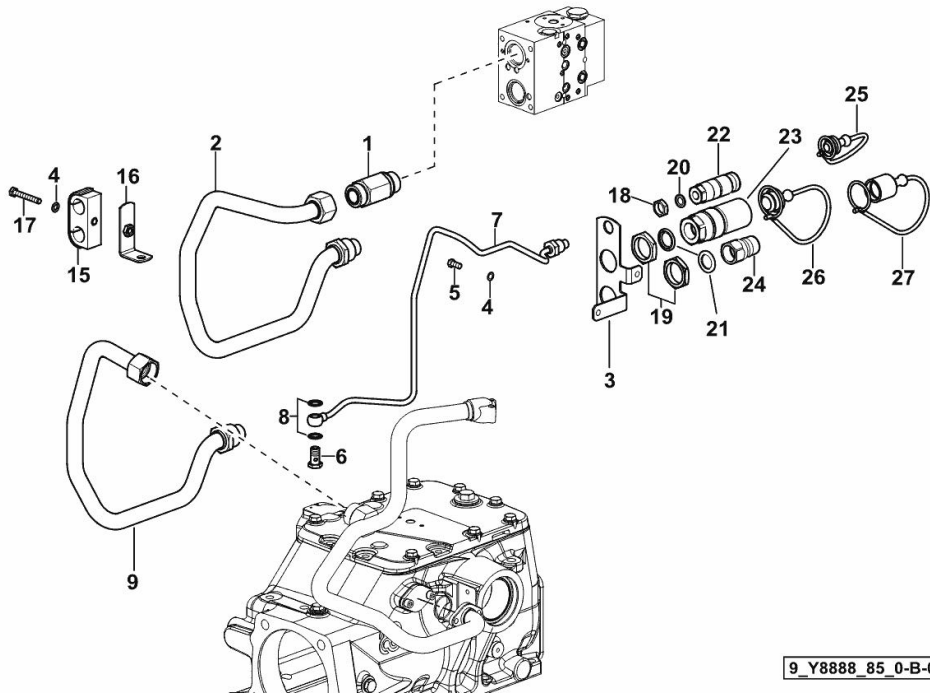

9_Y8888_85_0-B-001

REAR QUICK ACTION COUPLERS - POWERBEYOND

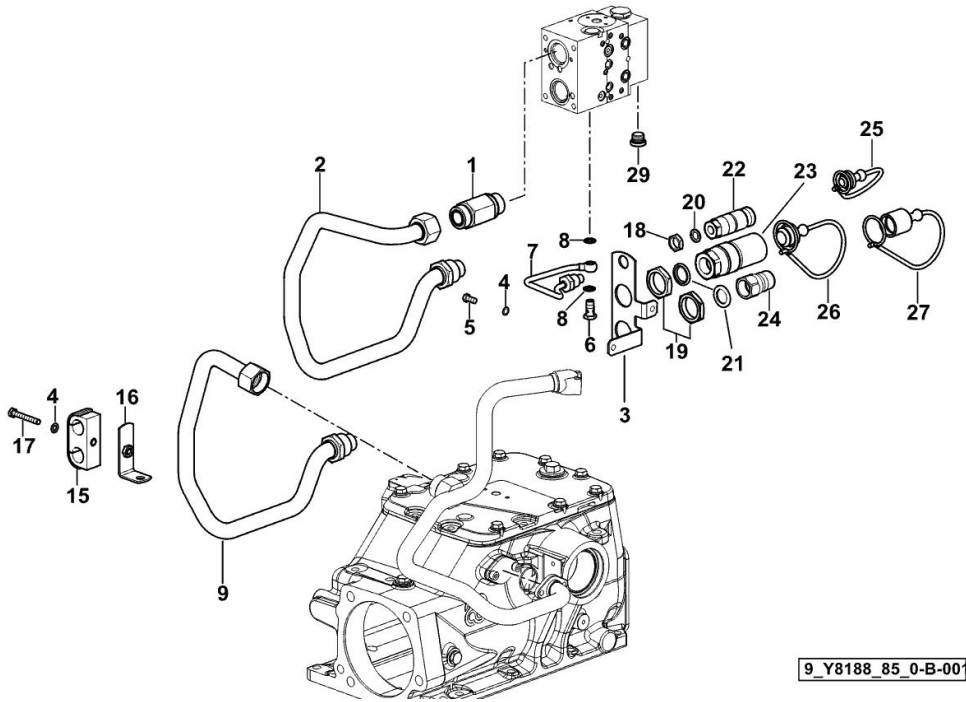

9_Y8188_85_0-B-001

Fig.	P/n	QTY	Name
------	-----	-----	------

Notes:

[5120P -> ZKDBA602W0TD20001]

1	2.3249.448.2	1	pipe fitting
2	0.019.4274.3	1	tube
3	0.017.7066.0	1	bracket
4	2.1470.004.2	3	lock washer 8
5	2.0112.205.2	2	screw m 8 p.1.25 x 16
6	2.3335.005.2	1	pipe union m 12 p.1.5 x 24
7	0.017.9012.3	1	tube
8	2.1561.106.0	2	gasket Ø 12 -B-
9	0.019.4277.3	1	tube
15	2.3329.004.0	1	terminal
16	0.017.9009.3	1	bracket
17	2.0112.220.2	1	screw m 8 p.1.25x55
18	2.1019.111.2	1	nut m 20 p.1.5
19	2.1019.146.2	2	nut m 36 p.2
20	2.1569.207.0	1	special oil seal G 1/4
21	2.1569.205.0	2	special oil seal G 3/4
22	2.3729.560.2	1	coupling 3/8
23	2.3729.570.2	1	coupling 3/4
24	2.3339.963.2	1	coupling 3/4
25	0.012.2605.0	1	plug 3/8 M
26	0.012.2603.0	1	plug 3/4 M
27	0.012.2604.0	1	plug 3/4 F
29	04454782	1	plug m 18 p.1.5

CONNECTOR OIL COLLECTION SYSTEM

Fig.	P/n	QTY	Name
------	-----	-----	------

Notes:

- FOR TYPES WITH MECHANICAL REMOTE VALVE CONTROL [5120P -> ZKDBA602W0TD20001]

1	0.015.3430.0	1	bracket
2	04426824.4	1	tank 600 cm ³
3	2.1475.004.2	1	spring washer 12
4	2.0112.407.2	1	screw m 12 p.1.75 x 20
5	2.6857.019.0	4	clamp 14
6	0.012.9660.0/10	0.75	flexible hose
7	2.6839.066.0/10	1	clamp 16
9	0.015.3818.3/10	1	bracket
10	2.1470.002.2	1	lock washer 6
11	2.0112.003.2	1	screw m 6 p.1 x 12

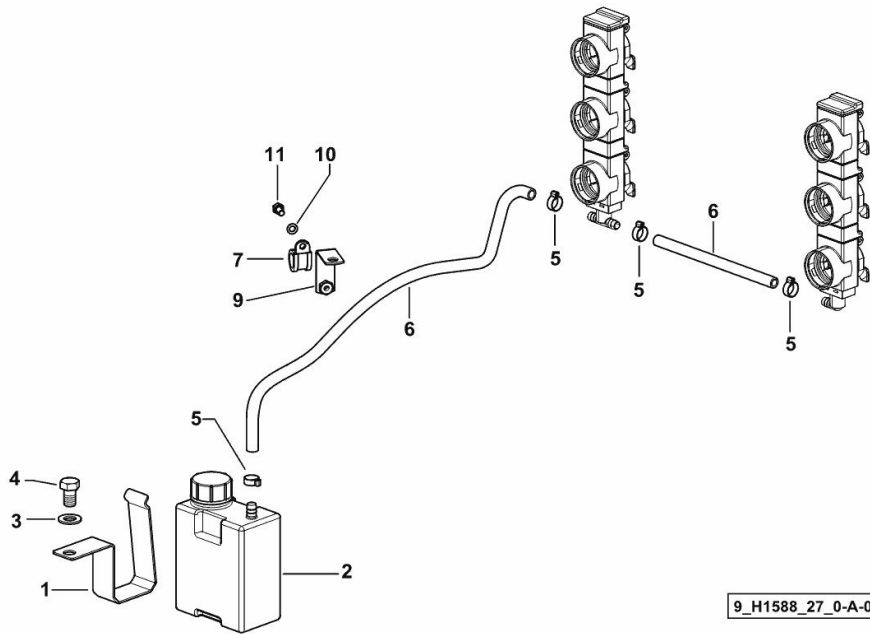

9_H1588_27_0-A-002

CONNECTOR OIL COLLECTION SYSTEM

Fig.	P/n	QTY	Name
------	-----	-----	------

Notes:
 - WITH ELECTRONIC 6-WAY REMOTE VALVE [5120P -> ZKDBA602W0TD20001]

1	0.017.8241.0	1	plug
2	0.017.8242.0	1	plug
3	0.017.8243.0	1	plug
4	2.6857.019.0	5	clamp 14
5	0.012.9660.0/10	0.25	flexible hose
6	0.012.9660.0/10	0.25	flexible hose
7	2.3249.456.0	1	pipe fitting Y
8	0.012.9660.0/10	0.37	flexible hose
9	0.012.9660.0/10	0.62	flexible hose
10	2.0112.407.2	2	screw m 12 p.1.75 x 20
11	2.1475.004.2	2	spring washer 12
12	0.015.3430.0	2	bracket
13	04426824.4	2	tank 600 cm ³
13.1	04428375	1	plug
14	2.6852.203.0	5	clamp 292 x 4.8
15	0.015.3818.3/10	1	bracket
16	2.6839.066.0/10	1	clamp 16
17	2.0112.003.2	1	screw m 6 p.1 x 12
18	2.1470.002.2	1	lock washer 6

9_R8888_27_0-A-002

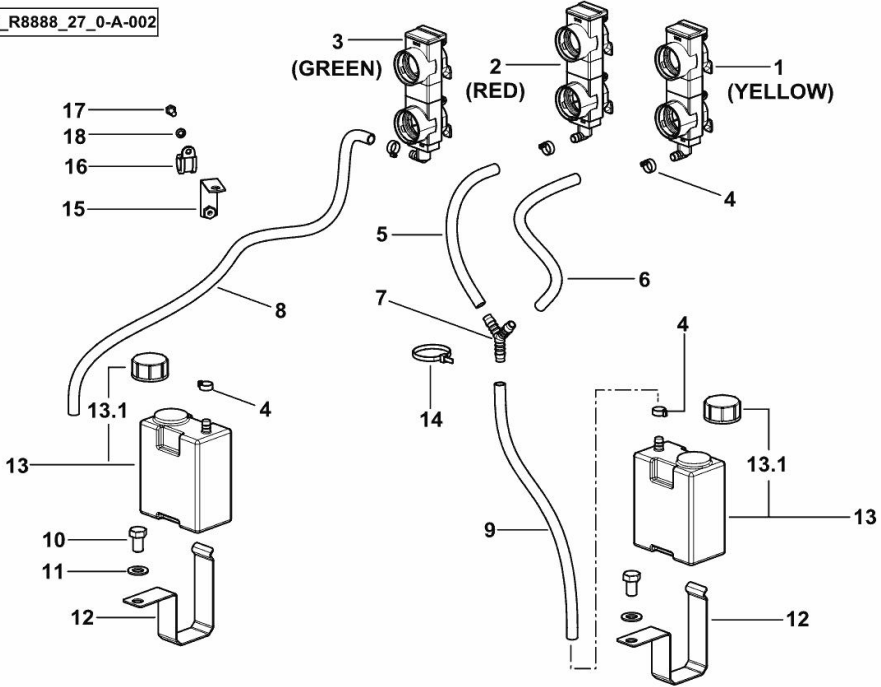

CONNECTOR OIL COLLECTION SYSTEM

Fig.	P/n	QTY	Name
------	-----	-----	------

Notes:
 - WITH ELECTRONIC 8-WAY REMOTE VALVE [5120P -> ZKDBA602W0TD20001]

9_R8888_37_0-A-002

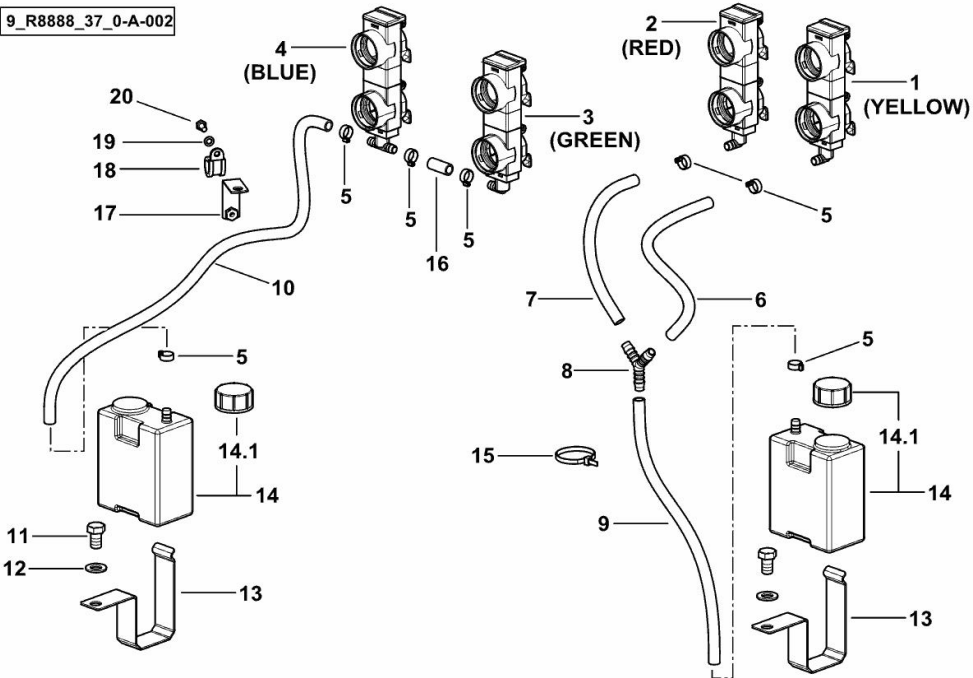

1	0.017.8241.0	1	plug
2	0.017.8242.0	1	plug
3	0.017.8243.0	1	plug
4	0.017.8244.0	1	plug
5	2.6857.019.0	6	clamp 14
6	0.012.9660.0/10	0.25	flexible hose
7	0.012.9660.0/10	0.25	flexible hose
8	2.3249.456.0	1	pipe fitting Y
9	0.012.9660.0/10	0.37	flexible hose
10	0.012.9660.0/10	0.62	flexible hose
11	2.0112.407.2	2	screw m 12 p.1.75 x 20
12	2.1475.004.2	2	spring washer 12
13	0.015.3430.0	2	bracket
14	04426824.4	2	tank 600 cm ³
14.1	04428375	1	plug
15	2.6852.203.0	5	clamp 292 x 4.8
16	0.012.9660.0/10	0.03	flexible hose
17	0.015.3818.3/10	1	bracket
18	2.6839.066.0/10	1	clamp 16
19	2.1470.002.2	1	lock washer 6
20	2.0112.003.2	1	screw m 6 p.1 x 12

10-WAY REMOTE VALVES - OIL RECOVERY

Fig.	P/n	QTY	Name
------	-----	-----	------

Notes:

- FOR TYPES WITH ELECTRICAL REMOTE VALVE CONTROL [5120P -> ZKDBA602W0TD20001]

1	0.017.8241.0	1	plug - YELLOW COLOUR
2	0.017.8242.0	1	plug - RED COLOUR
3	0.017.8243.0	1	plug - COLORE VERDE
4	0.017.8244.0	1	plug - BLUE COLOUR
5	0.019.1150.0	1	plug - BROWN
6	2.6857.019.0	8	clamp 14
7	0.012.9660.0/10	0.25	flexible hose
8	0.012.9660.0/10	0.25	flexible hose
9	2.3249.456.0	2	pipe fitting Y
10	0.012.9660.0/10	0.37	flexible hose
11	0.012.9660.0/10	0.03	flexible hose
12	0.012.9660.0/10	0.2	flexible hose
13	0.012.9660.0/10	0.34	flexible hose
14	0.012.9660.0/10	0.38	flexible hose
15	2.0112.407.2	2	screw m 12 p.1.75 x 20
16	2.1475.004.2	2	spring washer 12
17	0.015.3430.0	2	bracket
18	04426824.4	2	tank 600 cm ³
18.1	04428375	1	plug
19	2.6852.203.0	8	clamp 292 x 4.8

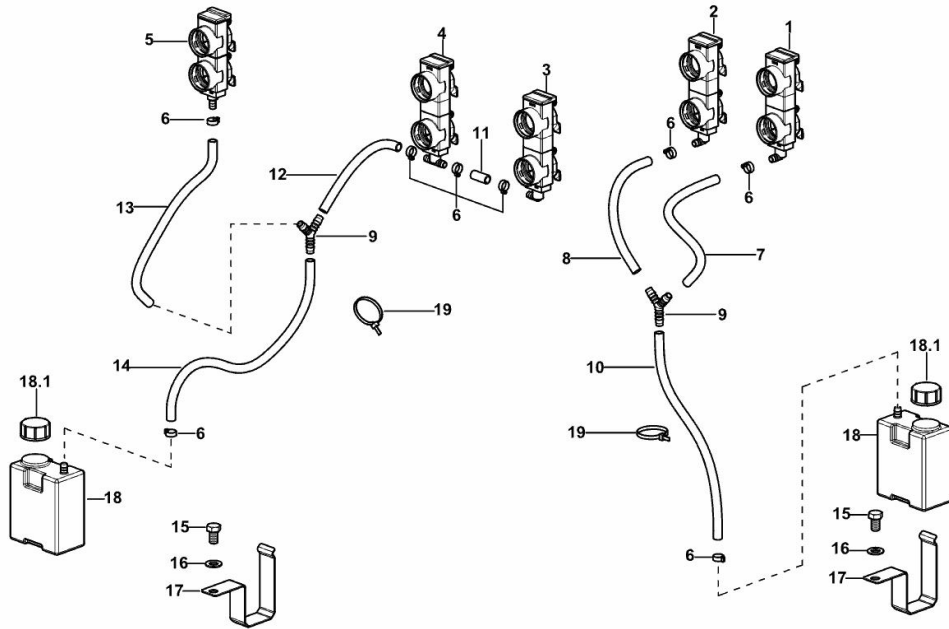

9_Y8888_47_0-A-001

FREE OIL RETURN

Fig.	P/n	QTY	Name
------	-----	-----	------

Notes:
 [5120P -> ZKDBA602W0TD20001]

1	0.009.3149.0	1	plug
2	0.98309.51.3/10	1	coupling 1/2
3	2.1560.054.0	1	gasket 21 x 26
4	2.1019.091.2	1	special nut m 30 p.1.5x8
5	0.017.8498.3	1	bracket
6	0.017.8499.3	1	tube
7	2.1560.018.0	2	gasket 22.2 x 29
8	2.3339.660.2	1	pipe union

9_R8888_80_0-A-001

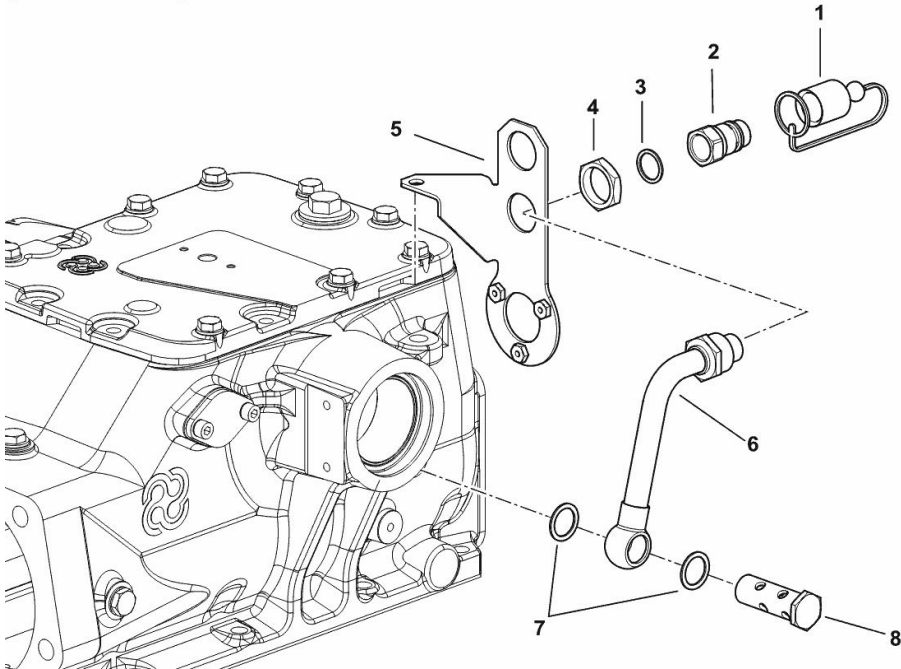

PIPE FROM AUXILIARY CONTROL VALVE TO ELECTRONIC ACS - POWERBEYOND

Fig.	P/n	QTY	Name
------	-----	-----	------

Notes:

- FOR TYPES WITH SUSPENDED DRIVING AXLE [5120P -> ZKDBA602W0TD20001]

10	0.017.9011.3	1	tube
11	2.1480.012.2	3	washer 6, d128
12	2.0312.112.2	3	screw m 6 p.1 x 35
13	2.1532.071.0	1	oil seal 26.64x2.62
14	2.1532.092.0	1	ring 34.65x1.78
28	2.1011.405.2	2	nut m 8 p.1

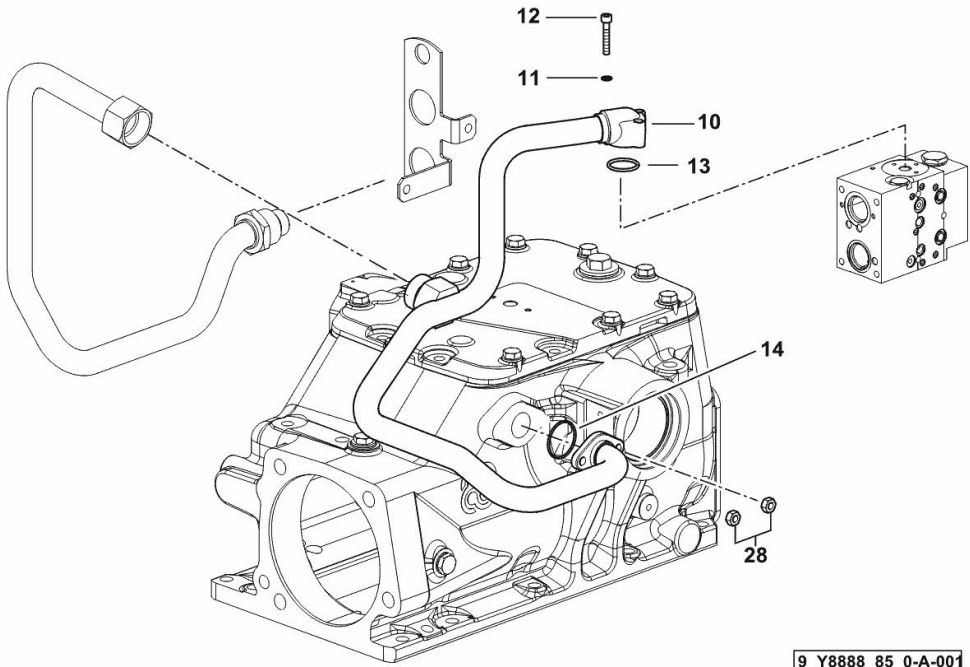

9_Y8888_85_0-A-001

Buy Now



Our support email:

ebooklibonline@outlook.com