

FOLDING STRAW WALKER

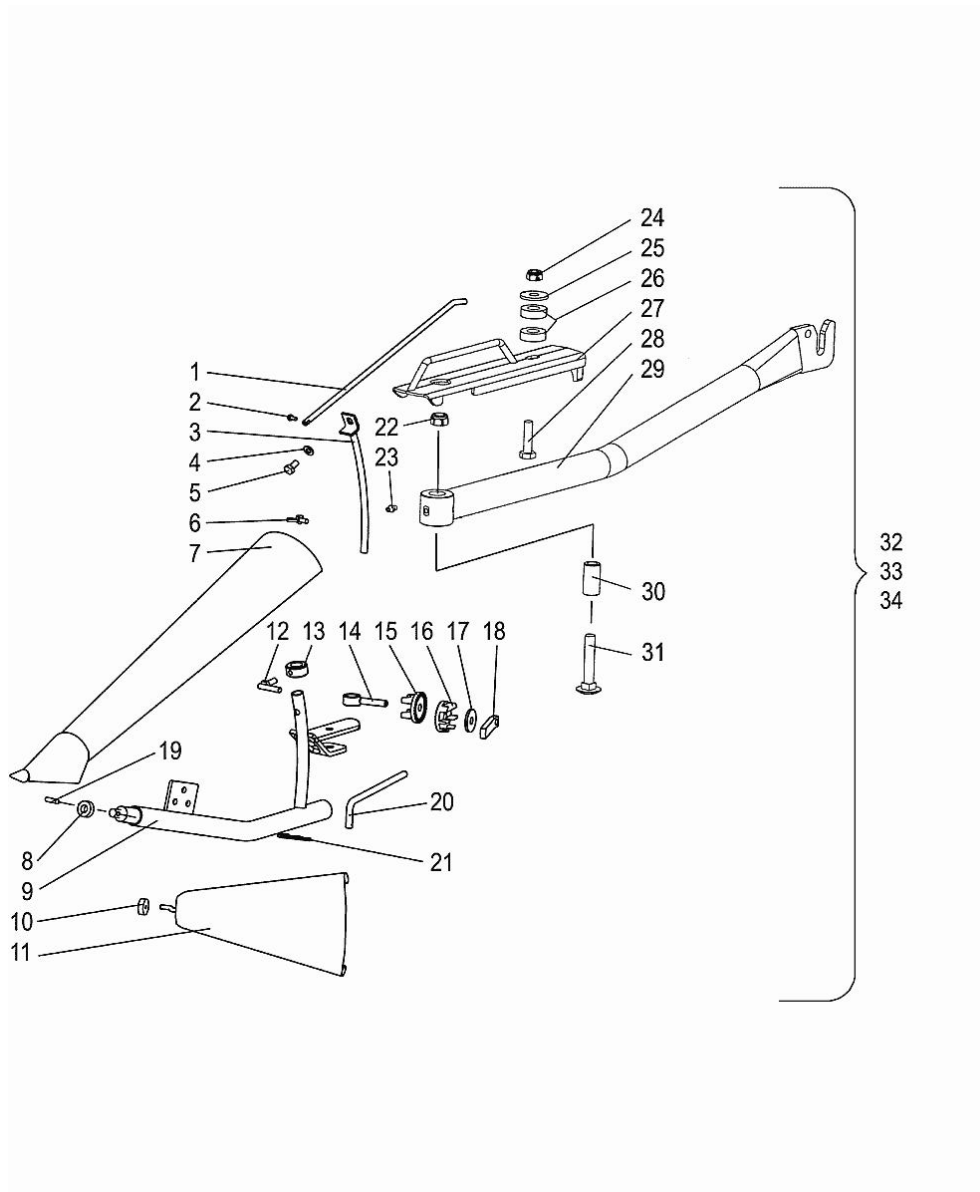

Fig.	P/n	QTY	Name
Notes:			
[5485HT]			
1	R702528	1	rod
2	6210667	1	screw
3	R702524	1	rod
4	7400033	1	washer
5	6226167	1	screw
6	6290034	1	screw
7	R702516	1	plate
8	R618931	1	shock absorber
9	R702502	1	tube
10	R619014	1	shock absorber
11	R702521	1	small guard
12	R596034	1	screw
13	R596036	1	ring
14	R615795	1	screw
15	R616697	1	adjustable tensioner
16	R082544	1	adjustable tensioner
17	7414062	1	washer
18	R595936	1	nut
19	7814198	1	pin
20	R082536	1	adjustable tensioner
21	7812410	1	pin
22	6594238	1	nut
23	0252405	1	grease gun
24	6594148	1	nut
25	7414059	1	washer
26	R618931	1	shock absorber
27	R702540	1	handle
28	6226767	1	screw
29	R702508	1	hook
30	R702539	1	bushing
31	6771844	1	screw
32	R702500	1	separator
			RIGHT-HAND SIDE
33	R702501	1	separator
			LEFT-HAND SIDE
34	R702485	1	separator - KIT
			INCLUDES 32, 33

LONG DIVIDERS, WB

Fig.	P/n	QTY	Name
------	-----	-----	------

Notes:
[5485HT]

1	R625236	1	cover
3	R618931	2	shock absorber
4	R698832	2	tube
5	7814198	2	pin
6	R619014	4	shock absorber
7	R618954	2	rod
8	6226167	2	screw
9	R618960	2	rod
10	7400033	2	washer
11	7414471	2	washer
12	6506434	4	nut
13	R615795	2	screw
14	7812410	2	pin
15	R082536	2	adjustable tensioner
16	R616697	2	adjustable tensioner
17	R082544	2	adjustable tensioner
18	7414062	2	washer
19	R595936	4	nut
20	R596036	2	ring
21	R596034	2	screw
22	R698830	1	separator LEFT-HAND SIDE
23	R698831	1	separator RIGHT-HAND SIDE
24	R698848	1	separator INCLUDES 23, 24
42	R588385	2	plate
43	7814285	2	pin

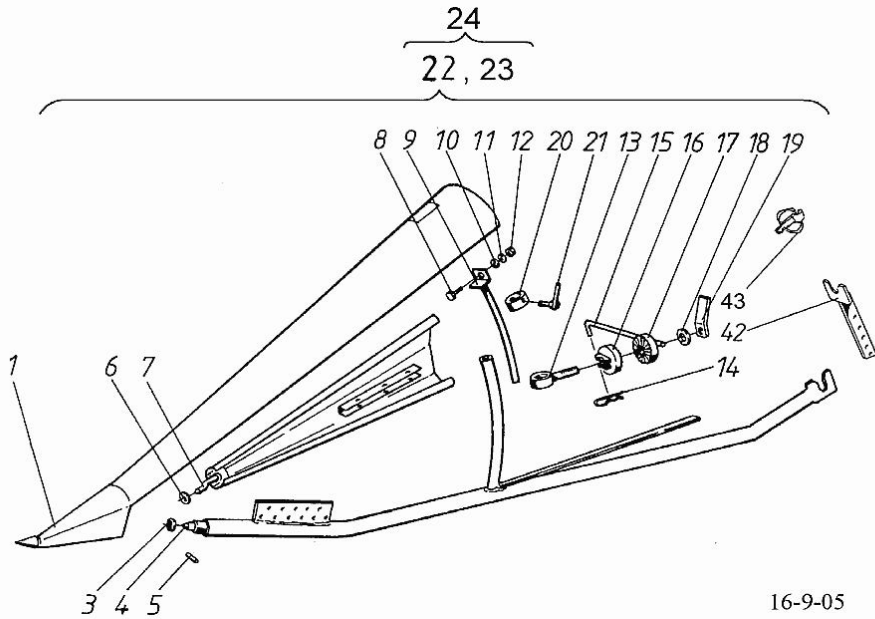

LONG DIVIDERS, KK

Fig.	P/n	QTY	Name
------	-----	-----	------

Notes:
[5485HT]

1	R625236	1	cover LEFT-HAND SIDE
2	R625237	1	cover RIGHT-HAND SIDE
3	R618931	2	shock absorber
4	R618968	2	tube
5	7814198	2	pin
6	R619014	4	shock absorber
7	R618954	2	rod
8	6226167	2	screw
9	R618960	2	rod
10	7400033	2	washer
11	7414471	2	washer
12	6506434	4	nut
13	R615795	2	screw
14	7812410	2	pin
15	R082536	2	adjustable tensioner
16	R616697	2	adjustable tensioner
17	R082544	2	adjustable tensioner
18	7414062	2	washer
19	R595936	4	nut
20	R596036	2	ring
21	R596034	2	screw
22	R640998	1	separator
42	R588385	2	plate
43	7814285	2	pin

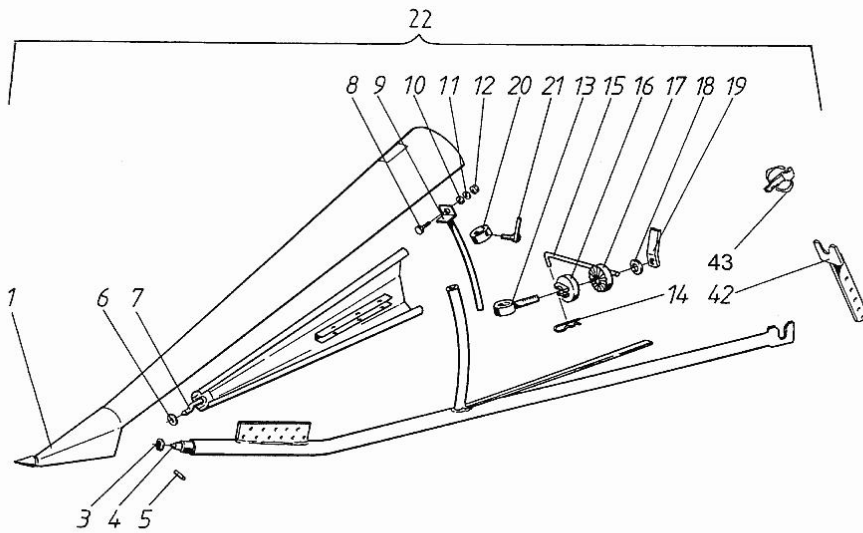

SHORT DIVIDERS, KK

Fig.	P/n	QTY	Name
------	-----	-----	------

Notes:
[5485HT]

3	R618931	2	shock absorber
5	7814198	2	pin
8	6226167	2	screw
11	7414471	2	washer
12	6506434	4	nut
20	R596036	2	ring
21	R596034	2	screw
31	R679079	1	cover
32	R679089	1	pin
33	R679087	1	support
34	R679076	2	tube
35	R699884	1	stay
36	6506234	2	nut
37	7414469	2	washer
38	6221267	4	screw
41	R679083	1	separator - KIT
42	R588385	2	plate
43	7814285	2	pin

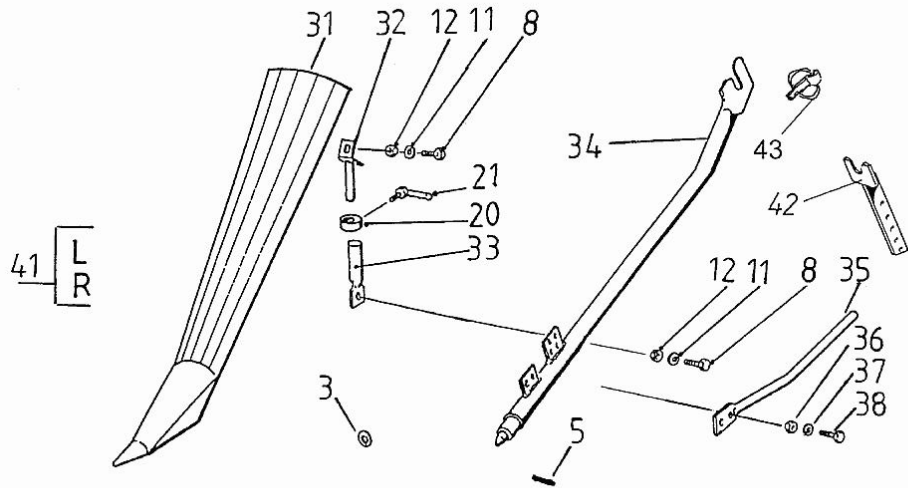

SIDETUBE

Fig.	P/n	QTY	Name
------	-----	-----	------

Notes:
[5485HT]

6	R619014	4	shock absorber
12	6506434	4	nut
19	R595936	4	nut
25	R618963	1	tube
25	R652141	1	tube
			For Norway
26	R596035	4	screw
27	R595864	2	support
28	R595865	2	tube
29	R082550	2	adjustable tensioner
42	6226977	2	screw
49	R643603	1	adjustable tensioner

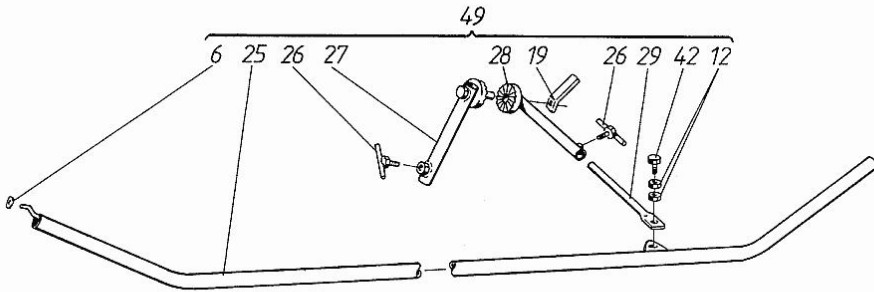

BOW DIVIDER

Fig.	P/n	QTY	Name
------	-----	-----	------

Notes:
[5485HT]

38	6221267	4	screw
42	R588385	2	plate
43	7814285	2	pin
51	R698840	1	tube
52	6594048	2	nut
53	R683151	1	tube
54	7400032	2	washer
55	R698841	1	tube
			LEFT-HAND SIDE
56	R698842	1	tube
			RIGHT-HAND SIDE
57	R698850	1	tube - KIT
			INCLUDES 55, 56

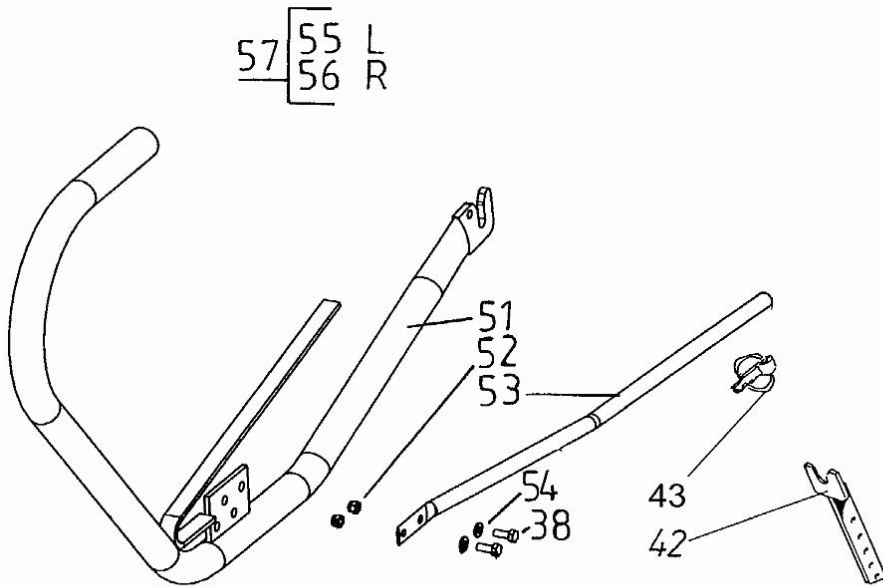

VERTICAL BLADES, DX/RH/RE

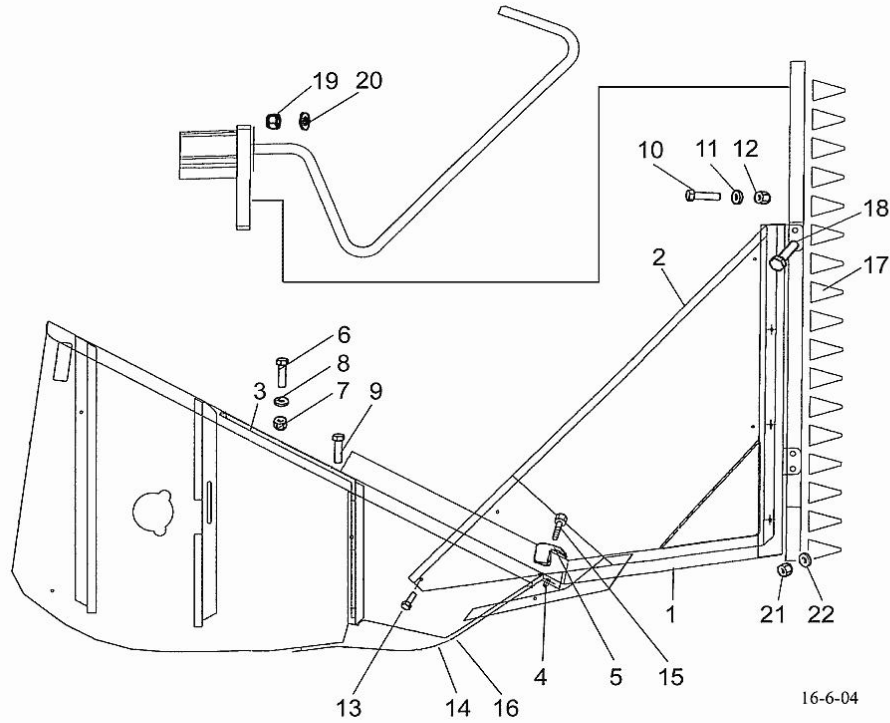

Fig.	P/n	QTY	Name
------	-----	-----	------

Notes:
[5485HT]

1	R693509	1	support
2	R693516	1	plate
3	R693522	1	support
4	R693507	1	clamp
5	R693508	1	clamp
6	6226367	7	screw
7	6594148	24	nut
8	7400033	24	washer
9	6226567	4	screw
10	6212877	4	screw
11	7400030	9	washer
12	6593838	5	nut
13	6210667	1	screw
14	6763544	9	screw
15	6228977	2	screw
16	R693518	1	support
17	0493084	1	blade
18	6226967	2	screw
19	6594038	2	nut
20	7400032	2	washer
21	6506234	2	nut
22	7414469	2	washer

VERTICAL BLADES, SX/LH/LI

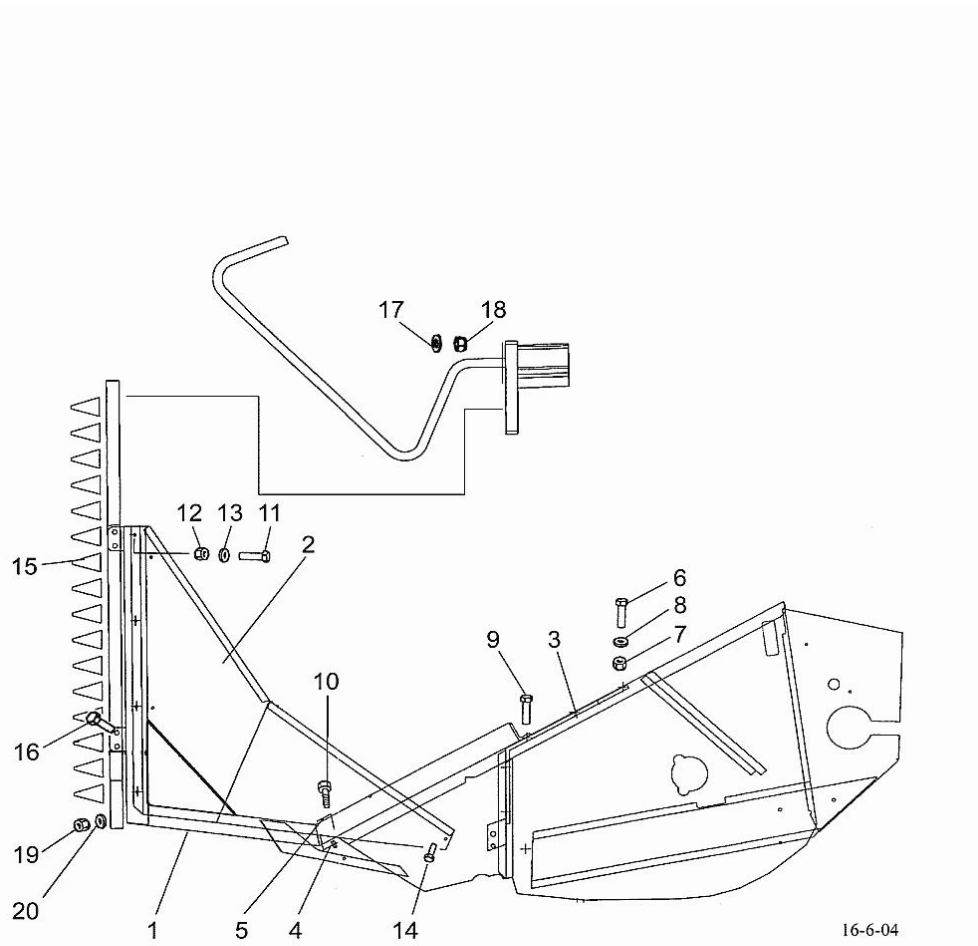

Fig.	P/n	QTY	Name
------	-----	-----	------

Notes:
[5485HT]

1	R693520	1	support
2	R693523	1	plate
3	R693521	1	support
4	R693507	1	clamp
5	R693508	1	clamp
6	6226367	5	screw
7	6594148	11	nut
8	7400033	11	washer
9	6226567	4	screw
10	6228977	2	screw
11	6212877	4	screw
12	6593838	5	nut
13	7400030	9	washer
14	6210667	1	screw
15	0493084	1	blade
16	6226967	2	screw
17	6594038	2	nut
18	7400032	2	washer
19	6506234	2	nut
20	7414469	2	washer

EARLIFTERS

Fig.	P/n	QTY	Name
------	-----	-----	------

Notes:
[5485HT]

1	0498864	9	earlifter L = mt. 3,1
---	---------	---	--------------------------

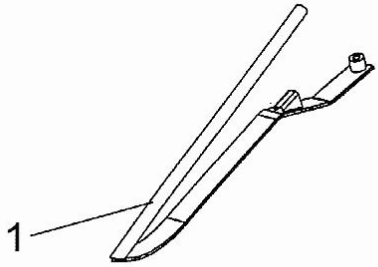
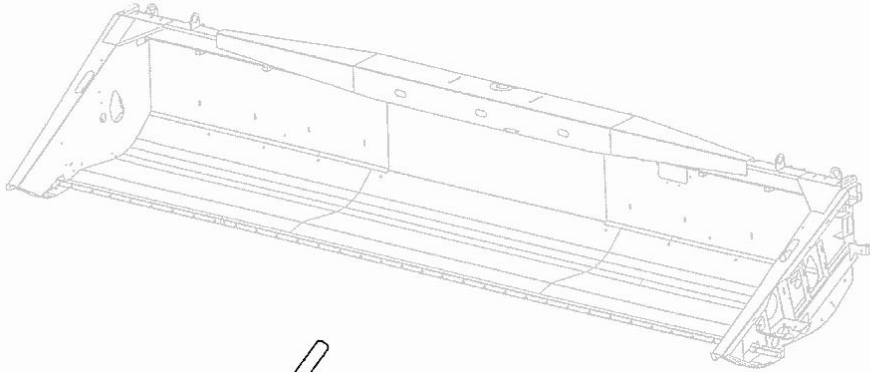

▶◀ 3,1m x 9
 3,4m x 10
 3,9m x 12
 4,2m x 13
 4,5m x 14
 4,8m x 15
 5,1m x 16

CUTTING TABLE'S COMMON PARTS

Fig.	P/n	QTY	Name
------	-----	-----	------

Notes:
[5485HT]

4	R687106	1	support
5	6598504	2	wing nut
6	7400030	10	washer
7	R678333	1	stopper
17	6506234	30	nut
37	R594817	2	support
38	8020236	2	reflector
40	6593838	5	nut
42	6211067	5	screw
54	R689393	1	plate
55	R689394	1	plate
RIGHT-HAND SIDE			
56	7268607	4	block
62	R691390	2	guard
63	0812714	2	plate
64	6598704	2	nut
65	6221467	2	screw

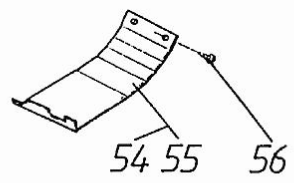
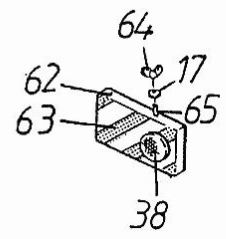
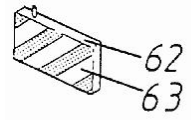
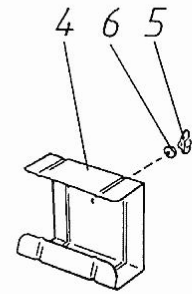
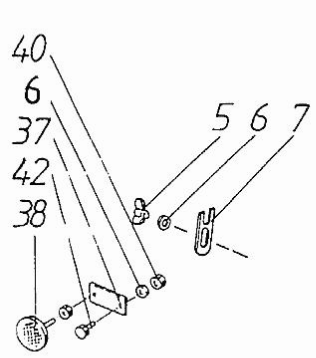

Thank you so much for reading.
Please click the “Buy Now!”
button below to download the
complete manual.



After you pay.

You can download the most
perfect and complete manual in
the world immediately.

Our support email:

ebooklibonline@outlook.com