

CRANKCASE

| Fig. | P/n | QTY | Name |
|------|-----|-----|------|
|------|-----|-----|------|

Notes:

[603 LD 2WD] -> 9960 [603 LD 4WD] -> 9960

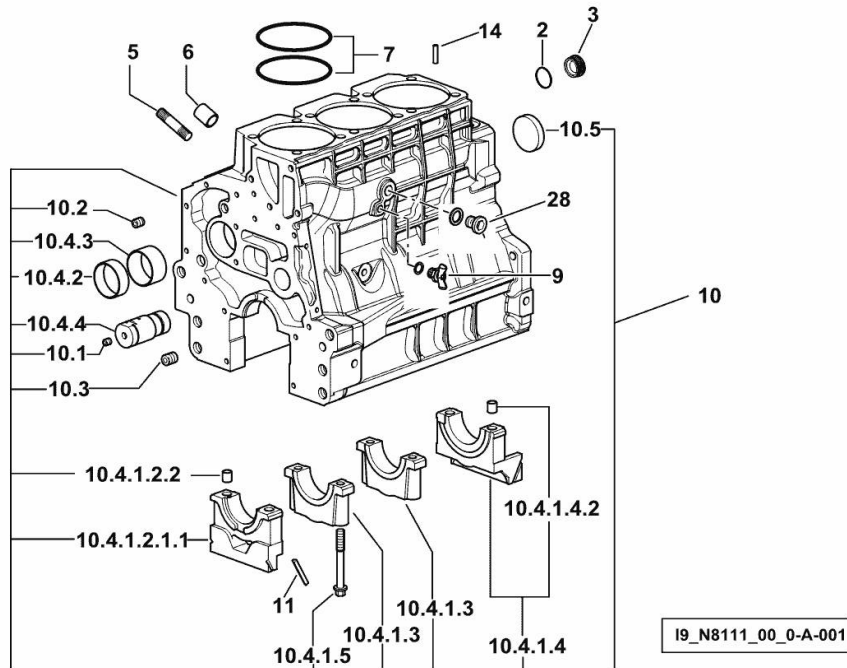

| | | | |
|--------------|-----------------|----|---------------------------------|
| 2 | 2.1532.072.0 | 1 | oil seal 26.70x1.78 |
| 3 | 2.3199.405.2 | 1 | plug m 28 p.1.5 |
| 5 | 2.0432.003.7 | 11 | stud bolt m 8 p.1.25 / p.1 x 20 |
| 6 | 2.1559.188.2 | 3 | bush 11.4 x 14 x16 |
| 7 | 2.1539.259.0 | 6 | special oil seal 107.62x2.62 |
| 9 | 0.049.1152.0 | 1 | cock |
| 10 | 0.014.8700.4 | 1 | crankcase |
| 10.1 | 2.3130.001.1 | 9 | plug 1/8" gas |
| 10.2 | 2.3130.002.1 | 2 | plug 1/4" gas |
| 10.3 | 2.3130.003.1 | 2 | plug 3/8" gas |
| 10.4.1.2.1.1 | 0.065.1112.7/10 | 1 | support |
| 10.4.1.2.2 | 2.1699.165.0 | 1 | bush 12.3x15x16 |
| 10.4.1.3 | 0.065.1114.0/10 | 2 | support |
| 10.4.1.4 | 0.065.1116.3 | 1 | support |
| 10.4.1.4.2 | 2.1699.165.0 | 1 | bush 12.3x15x16 |
| 10.4.1.5 | 0.065.1117.0 | 8 | screw m 12 x 100 |
| 10.4.2 | 0.065.1140.0 | 3 | special bushing 59X55X20 |
| 10.4.3 | 0.065.1141.0 | 1 | special bushing 59X55X30 |
| 10.4.4 | 0.014.1340.0 | 1 | pin |
| 10.5 | 2.3179.012.0 | 1 | plug 60 |
| 11 | 0.066.1152.0/10 | 4 | gasket |
| 14 | 2.1549.154.2 | 3 | bush 4.8x5.8x16 |
| 28 | 2.3131.004.2 | 1 | plug m 18 p.1.5 |

MONOBLOC ENGINE-GEARBOX CONNECTING FLANGE

| Fig. | P/n | QTY | Name |
|------|-----|-----|------|
|------|-----|-----|------|

Notes:

[603 LD 2WD]-> 16415 [603 LD 4WD]-> 16415

| | | | |
|---|--------------|---|-------------------------------|
| 1 | 0.015.8814.0 | 1 | flange |
| 2 | 2.0112.511.2 | 8 | screw m 14 p.2 x 30 |
| 3 | 2.0432.255.7 | 2 | stud bolt m 12 p.1.75-1.25x25 |
| 4 | 2.1651.912.0 | 4 | cylindrical plug 12x28 |
| 5 | 2.0512.404.7 | 2 | screw |

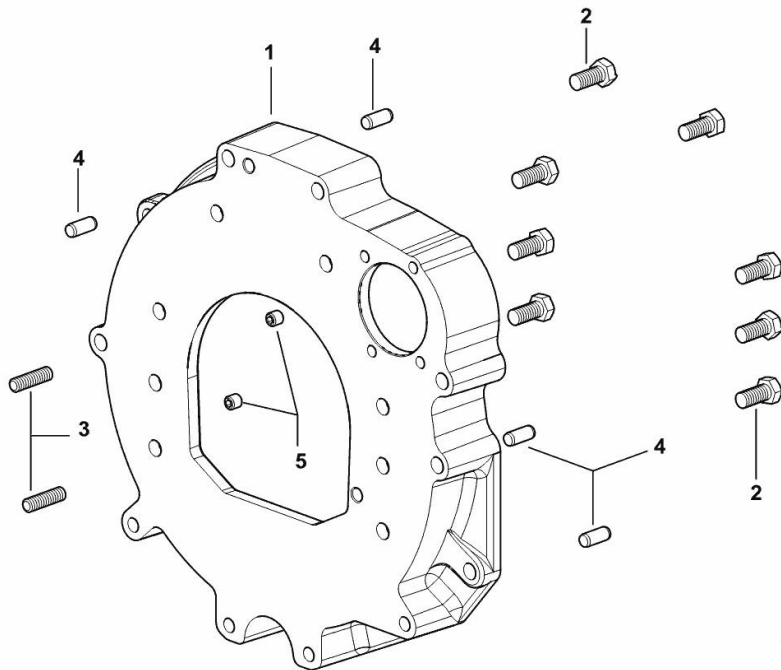

I9_38511_01_0-A-001

CRANKSHAFT

| Fig. | P/n | QTY | Name |
|------|-----|-----|------|
|------|-----|-----|------|

Notes:

[603 LD 2WD] -> 9960 [603 LD 4WD] -> 9960

| | | | |
|------|-----------------|---|-----------------------------|
| 7.1 | 0.007.1554.0/20 | 1 | crankshaft |
| 8 | 0.065.1215.0/10 | 4 | main half bushing STANDARD |
| 9 | 0.065.1216.0/10 | 4 | main half bushing STANDARD |
| 10 | 0.065.1218.0 | 4 | shim STANDARD |
| 15 | 0.065.1254.0/20 | 1 | gasket |
| 16 | 0.007.1711.0/10 | 1 | cover |
| 17 | 2.1475.002.2 | 9 | conical washer 8 |
| 18 | 2.0112.207.2 | 9 | screw m 8 p 1.25 x 20 |
| 19 | 2.1529.073.0 | 1 | special oil seal 110x130x13 |
| 22 | 2.1599.524.7 | 1 | washer 21x60x12 |
| 23 | 0.065.1323.0/30 | 1 | gear Z = 29 |
| 24 | 2.1651.915.0 | 1 | pin 12x35 |
| 25 | 2.3130.001.1 | 3 | plug 1/8" gas |
| 26 | 2.1720.006.0 | 1 | key 4x6.5 |
| 801 | 0.065.1215.7 | 1 | main half bushing - mm 0.25 |
| 802 | 0.065.1215.8 | 1 | main half bushing - mm 0.50 |
| 901 | 0.065.1216.7 | 1 | main half bushing - mm 0.25 |
| 902 | 0.065.1216.8 | 1 | main half bushing - mm 0.50 |
| 1001 | 0.065.1218.7 | 1 | shim + mm 0.10 |
| 1002 | 0.065.1218.8 | 1 | shim + mm 0.15 |

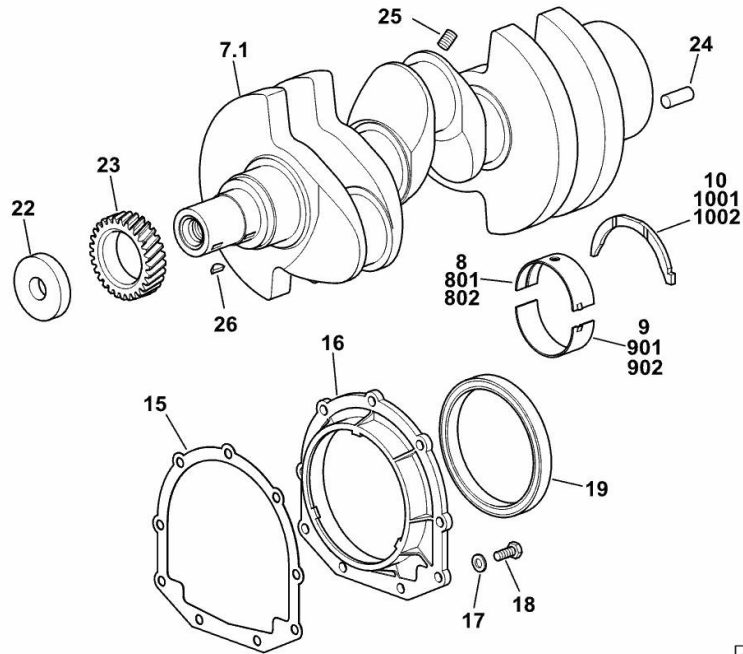

19_N8112_00_0-A-001

Section: B0 - ENGINE

CRANKSHAFT PULLEY

| Fig. | P/n | QTY | Name |
|------|-----|-----|------|
|------|-----|-----|------|

Notes:

[603 LD 2WD] -> 9960 [603 LD 4WD] -> 9960

| | | | |
|---|-----------------|---|---------------------|
| 3 | 0.014.5093.0 | 1 | pulley |
| 5 | 0.085.1248.0/20 | 1 | hub |
| 6 | 2.0399.144.7/10 | 1 | screw m 20 p.1.5x51 |
| 8 | 2.1720.006.0 | 1 | key 4x6.5 |

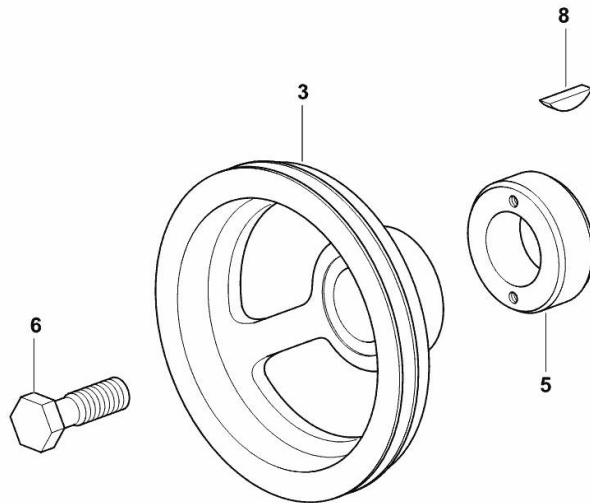

19_38512_04_0-A-001

CRANKSHAFT PULLEY

| Fig. | P/n | QTY | Name |
|------|-----|-----|------|
|------|-----|-----|------|

Notes:

- FOR TYPES WITH AIR BARKING - I.S.R.O. [603 LD 2WD]

| | | | |
|---|-----------------|---|---------------------|
| 3 | 0.012.0659.0 | 1 | none |
| 5 | 0.085.1248.0/20 | 1 | hub |
| 6 | 2.0399.144.7/10 | 1 | screw m 20 p.1.5x51 |
| 8 | 2.1720.006.0 | 1 | key 4x6.5 |

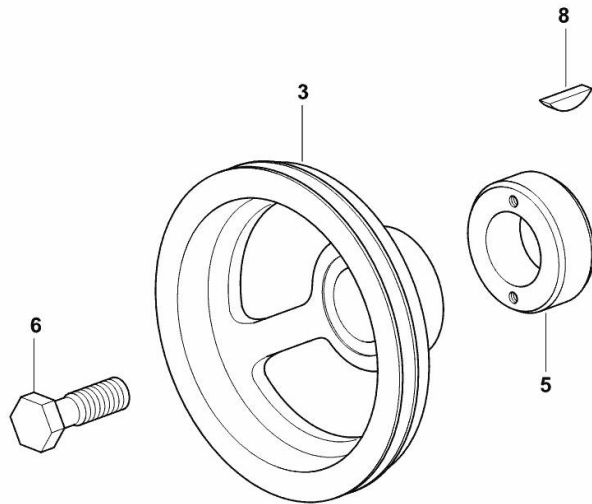

19_38512_11_0-A-001

Section: B0 - ENGINE
ENGINE FLYWHEEL

| Fig. | P/n | QTY | Name |
|------|-----|-----|------|
|------|-----|-----|------|

Notes:

[603 LD 2WD] -> 9960

| | | | |
|-----|-----------------|---|-----------------------|
| 1 | 0.012.0925.3 | 1 | flywheel |
| 1.2 | 0.069.1242.0 | 1 | crown wheel Z = 121 |
| 2 | 2.0119.174.0/10 | 6 | screw m 12 p.1.25x45 |
| 3 | 2.2041.008.9 | 1 | ball bearing 20x47x14 |

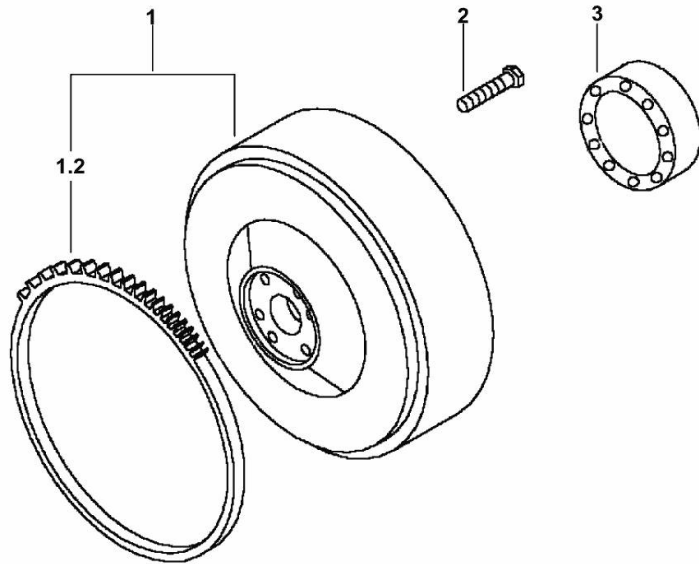

19_38512_02_0-A-001

ENGINE FLYWHEEL

| Fig. | P/n | QTY | Name |
|------|-----|-----|------|
|------|-----|-----|------|

Notes:

[603 LD 4WD] -> 10039 [603 LD 2WD] -> 10039

| | | | |
|-----|-----------------|---|-----------------------|
| 1 | 0.007.1617.3/30 | 1 | flywheel |
| 1.2 | 0.069.1242.0 | 1 | crown wheel Z = 121 |
| 2 | 2.0119.174.0/10 | 6 | screw m 12 p.1.25x45 |
| 3 | 2.2041.008.9 | 1 | ball bearing 20x47x14 |

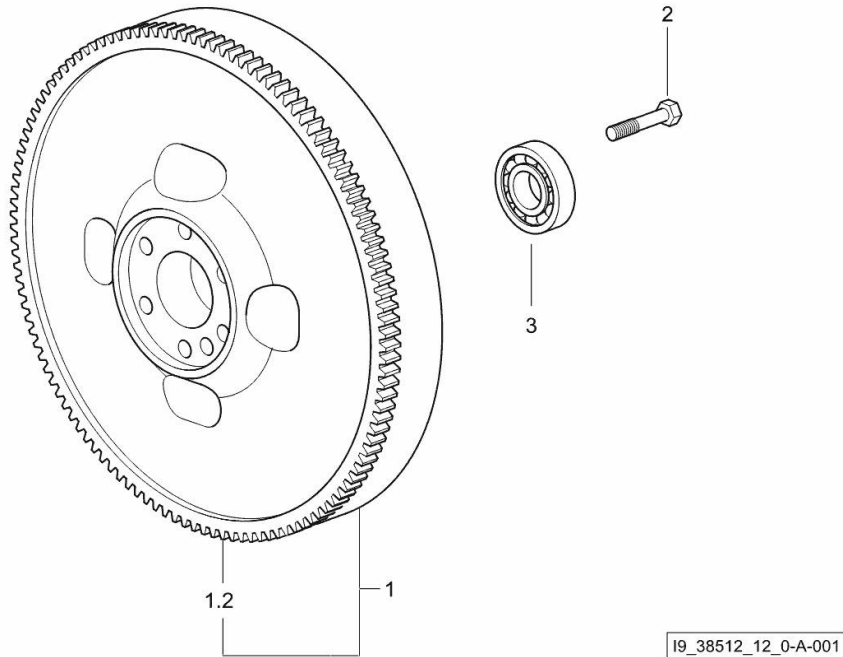

ENGINE FLYWHEEL

| Fig. | P/n | QTY | Name |
|------|-----|-----|------|
|------|-----|-----|------|

Notes:

- FOR TYPES WITH SAFETY CLUTCH [603 LD 2WD] - FOR TYPES WITH SAFETY CLUTCH [603 LD 4WD]

| | | | |
|-----|-----------------|---|-----------------------|
| 1 | 0.014.6127.3 | 1 | none |
| 1.2 | 0.069.1242.0 | 1 | crown wheel Z = 121 |
| 2 | 2.0119.174.0/10 | 6 | screw m 12 p.1.25x45 |
| 3 | 2.2041.008.9 | 1 | ball bearing 20x47x14 |

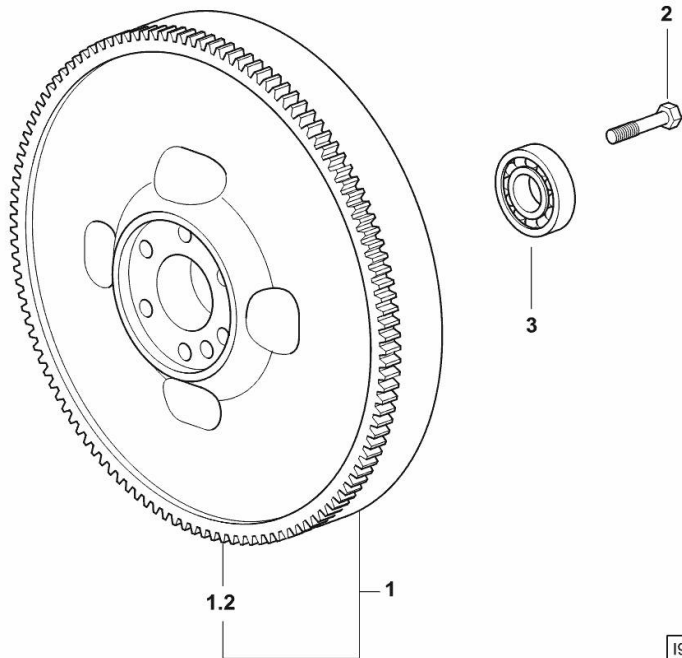

19_N8012_02_0-A-001

COOLANT PUMP DRIVEBELT

| Fig. | P/n | QTY | Name |
|------|-----|-----|------|
|------|-----|-----|------|

Notes:

[603 LD 2WD] [603 LD 4WD]

| | | | |
|----|--------------|---|---------------------------------------|
| 31 | 2.4119.139.0 | 1 | belt mm 10.7x1254 (19962 <-) |
| 31 | 2.4119.198.0 | 1 | vee belt AV 10.7x1240 mm (-> 20462) |

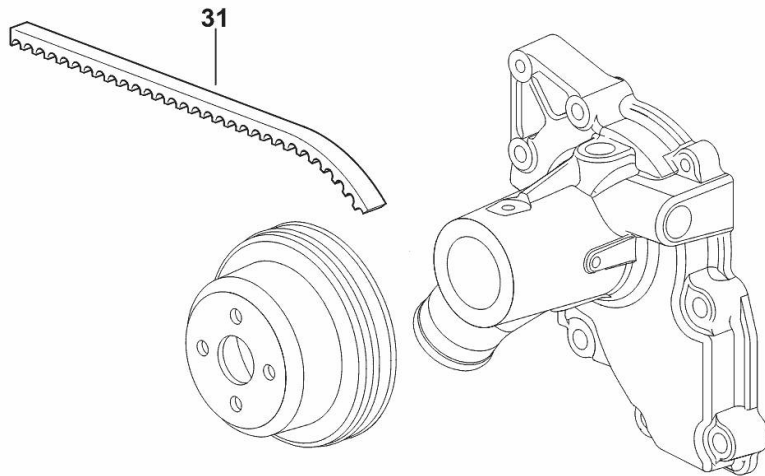

19_38519_11_0-B-001

CYLINDER - PISTON - CONNECTING ROD

| Fig. | P/n | QTY | Name |
|------|-----|-----|------|
|------|-----|-----|------|

Notes:

[603 LD 2WD] [603 LD 4WD]

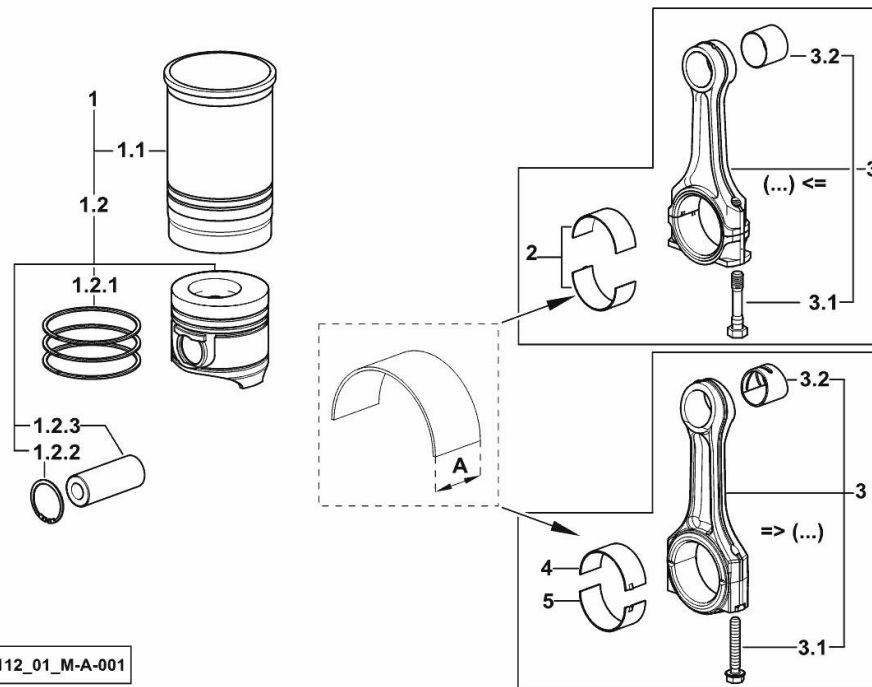

I9_N8112_01_M-A-001

| | | | |
|-------|-----------------|---|--|
| 1 | 0.386.0065.A | 3 | cyl. piston assembly "A" - CLASS A |
| 1 | 0.386.0065.B | 3 | cyl. piston assembly "B" - CLASS B |
| 1.1 | 0.A12.2675.0 | 1 | engine cylinder "A" - CLASS A |
| 1.1 | 0.B12.2675.0 | 1 | engine cylinder "B" - CLASS B |
| 1.2 | 0.379.0060.A | 1 | complete piston "A" - CLASS A |
| 1.2 | 0.379.0060.B | 1 | complete piston "B" - CLASS B |
| 1.2.1 | 0.086.0052.6/10 | 1 | piston ring set |
| 1.2.2 | 2.1411.014.1 | 1 | circlip 35 |
| 1.2.3 | 0.078.1236.0 | 1 | piston pin Ø 18 / Ø 35 / L = mm 86 |
| 2 | 0.065.1225.0 | 6 | con.rod half bushing STANDARD - A = 28.75 -> 29.00 (...) <= |
| 2 | 0.065.1225.7 | 6 | con.rod half bushing - mm 0.25 (...) <= |
| 2 | 0.065.1225.8 | 6 | con.rod half bushing - mm 0.50 (...) <= |
| 3 | 0.019.2226.3/10 | 1 | engine connecting rod => (...) |
| 3 | 0.078.1220.3/30 | 1 | engine connecting rod (...) <= |
| 3.1 | 2.0399.213.0 | 2 | screw m 12 p.1.25x61.5 (...) <= |
| 3.1 | 2.0399.365.0 | 2 | screw m 10 p.1.25x61.5 => (...) |
| 3.2 | 2.1559.114.0/10 | 1 | special bushing (...) <= |
| 3.2 | 2.1559.532.0 | 1 | special bushing 34.60x39.130x36.65 => (...) |
| 4 | 0.019.5453.0 | 3 | con.rod half bushing STANDARD - A = 29.85 -> 30.10 => (...) |
| 5 | 0.019.5454.0 | 3 | con.rod half bushing STANDARD - A = 29.85 -> 30.10 => (...) |

CAMSHAFT

| Fig. | P/n | QTY | Name |
|------|-----|-----|------|
|------|-----|-----|------|

Notes:

[603 LD 2WD] -> 9960 - 10891 <- [603 LD 4WD] -> 9960 - 10891 <-

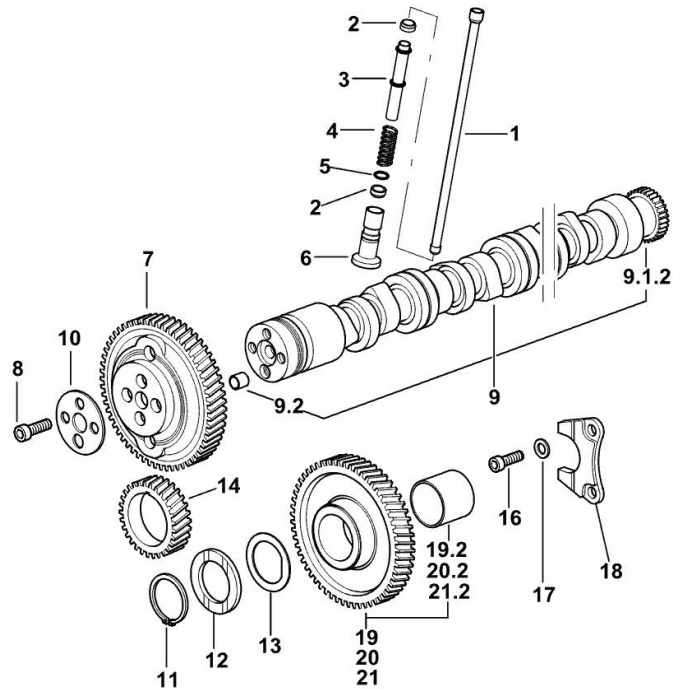

| | | | |
|-------|-----------------|-----|---------------------|
| 1 | 0.065.1331.2 | 6 | rod |
| 2 | 2.1569.114.0/10 | 12 | gasket 14x18.5x8 |
| 3 | 0.065.1332.0 | 6 | sleeve |
| 4 | 2.4019.300.1/10 | 6 | spring 18.5x52x2 |
| 5 | 2.1599.437.0 | 6 | shoulder ring |
| 6 | 0.065.1330.0 | 6 | tappets |
| 7 | 0.013.5017.0 | 1 | gear z=58 |
| 8 | 2.0132.207.2 | 4 | screw m 10 p.1 x 25 |
| 9 | 0.014.1945.4 | 1 | camshaft |
| 9.1.2 | 0.065.1324.0/10 | 1 | gear Z = 32 |
| 9.2 | 2.1559.398.0 | 1 | bushing 10.5x13x12 |
| 10 | 0.065.1350.0 | 1 | small disc |
| 11 | 2.1410.016.1 | 1 | circlip 40 |
| 12 | 0.065.1352.0 | 1 | shim |
| 13 | 0.065.1351.0 | 2 | shoulder ring |
| 14 | 0.065.1323.0/30 | 1 | gear Z = 29 |
| 16 | 2.0312.205.2 | 2 | screw |
| 17 | 2.1480.014.1 | 2 | washer 8 |
| 18 | 0.065.1353.0 | 1 | small plate |
| 19 | 0.007.1177.3/20 | 0.1 | gear z = 57 |
| 19.2 | 2.1559.185.0/10 | 1 | bushing |
| 20 | 0.007.1178.3/20 | 0.1 | gear z = 57 |
| 20.2 | 2.1559.185.0/10 | 1 | bushing |
| 21 | 0.007.1179.3/20 | 0.8 | gear z = 57 |
| 21.2 | 2.1559.185.0/10 | 1 | bushing |

19_N8113_00_0-A-001

CAMSHAFT

| Fig. | P/n | QTY | Name |
|------|-----|-----|------|
|------|-----|-----|------|

Notes:

[603 LD 2WD] -> 10798 [603 LD 4WD] -> 10798

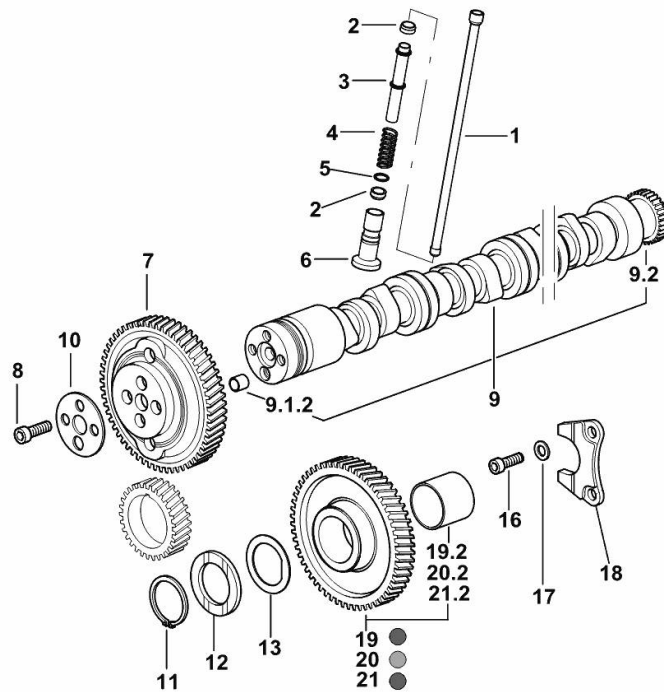

| | | | |
|-------|-----------------|-----|---|
| 1 | 0.065.1331.2 | 6 | rod |
| 2 | 2.1569.114.0/10 | 12 | gasket 14x18.5x8 |
| 3 | 0.065.1332.0 | 6 | sleeve |
| 4 | 2.4019.300.1/10 | 6 | spring 18.5x52x2 |
| 5 | 2.1599.437.0 | 6 | shoulder ring |
| 6 | 0.065.1330.0 | 6 | tappets |
| 7 | 0.013.5017.0 | 1 | gear z=58 |
| 8 | 2.0132.207.2 | 4 | screw m 10 p.1 x 25 |
| 9 | 0.012.8270.4 | 1 | camshaft |
| 9.1.2 | 2.1559.398.0 | 1 | bushing 10.5x13x12 |
| 9.2 | 0.065.1324.0/10 | 1 | gear Z = 32 |
| 10 | 0.065.1350.0 | 1 | small disc |
| 11 | 2.1410.016.1 | 1 | circlip 40 |
| 12 | 0.065.1352.0 | 1 | shim |
| 13 | 0.018.2233.0 | 2 | shoulder ring |
| 16 | 2.0312.205.2 | 2 | screw |
| 17 | 2.1480.014.1 | 2 | washer 8 |
| 18 | 0.065.1353.0 | 1 | small plate |
| 19 | 0.007.1177.3/20 | 0.1 | gear z = 57 - WITH RED IDENTIFICATION STAMP |
| 19.2 | 2.1559.185.0/10 | 1 | bushing |
| 20 | 0.007.1178.3/20 | 0.1 | gear z = 57 - WITH YELLOW IDENTIFICATION STAMP |
| 20.2 | 2.1559.185.0/10 | 1 | bushing |
| 21 | 0.007.1179.3/20 | 0.8 | gear z = 57 - WITH GREEN IDENTIFICATION STAMP |
| 21.2 | 2.1559.185.0/10 | 1 | bushing |

19_N8113_00_0-A-002

TIMING CASE

| Fig. | P/n | QTY | Name |
|------|-----|-----|------|
|------|-----|-----|------|

Notes:

[603 LD 2WD] -> 9960 [603 LD 4WD] -> 9960

| | | | |
|----|-----------------|----|---------------------------------|
| 5 | 2.0432.003.7 | 11 | stud bolt m 8 p.1.25 / p.1 x 20 |
| 16 | 2.0312.214.2 | 7 | screw m 8 p.1.25 x 40 |
| 17 | 2.1480.014.1 | 15 | washer 8 |
| 18 | 0.013.4981.0 | 1 | guard |
| 19 | 0.065.1150.0/30 | 1 | gasket |
| 20 | 2.1470.004.2 | 2 | lock washer 8 |
| 21 | 2.1011.405.2 | 2 | nut m 8 p.1 |
| 22 | 2.0312.208.2 | 8 | screw m 8 p.1.25 x 25 |
| 23 | 2.1529.167.0 | 1 | oil seal |

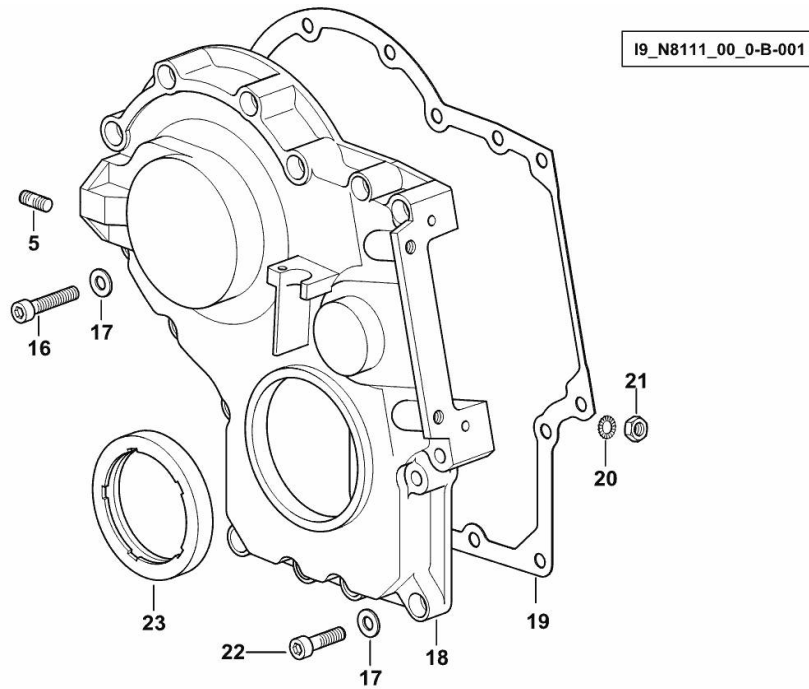

Section: B0 - ENGINE
CYLINDER HEAD

| Fig. | P/n | QTY | Name |
|------|-----|-----|------|
|------|-----|-----|------|

Notes:

[603 LD 2WD] -> 9960 [603 LD 4WD] -> 9960

| | | | |
|----------|-----------------|-----|------------------------------------|
| 1 | 2.0399.130.2/10 | 3 | screw m 8x36x44 |
| 2 | 2.1569.170.0/10 | 3 | gasket 8.2 x 14 |
| 3 | 0.016.0291.0 | 3 | small cap |
| 4 | 0.069.1450.0/30 | 1 | tappet gasket |
| 7 | 2.1011.421.2 | 6 | nut m 10 p.1.25 |
| 9.2 | 0.021.1434.0 | 2 | screw |
| 9.10.3 | 2.1011.405.2 | 2 | nut m 8 p.1 |
| 9.10.4 | 0.066.1432.3 | 2 | rocker arm |
| 9.10.4.2 | 2.1559.021.0/40 | 1 | bushing 15x19x22 |
| 9.10.5 | 2.1410.055.7 | 2 | circlip 19 |
| 9.10.6.1 | 0.066.1431.0 | 1 | pin |
| 9.10.6.2 | 0.066.1430.0/10 | 1 | support |
| 9.10.7 | 2.1599.432.0 | 2 | shoulder ring |
| 16 | 2.1530.051.0 | 3 | oil seal 20.22x3.53 |
| 17 | 0.012.2673.0 | 12 | screw m 14 p.2x141 |
| 18.1 | 0.014.8945.3/10 | 1 | head |
| 18.1.2 | 0.014.8942.0 | 1 | valve seat mm 45.118 |
| 18.1.3 | 0.014.8941.0 | 1 | valve seat mm 40.653 |
| 18.1.4 | 0.007.1779.0/20 | 2 | valve guide |
| 18.1.5 | 0.010.6041.0/10 | 1 | bush |
| 18.1.6 | 2.3170.012.2 | 2 | expansion plug Ø 30 |
| 18.2 | 0.066.1421.0 | 1 | exhaust valve |
| 18.3 | 0.010.6016.0 | 1 | inlet valve mm 43.63 / Ø mm 9 |
| 18.4 | 0.066.1425.0 | 2 | cup |
| 18.5 | 0.074.1423.0 | 4 | conical valve cotter |
| 18.6 | 2.4019.287.0 | 2 | spring |
| 18.7 | 2.1519.117.0 | 2 | special oil seal |
| 18.8 | 2.0432.161.7 | 1 | stud bolt m 10 p.1.5 / p.1.25 x 40 |
| 18.9 | 2.0432.163.7 | 2 | stud bolt m 10 p.1.5 / p.1.25 x 45 |
| 20 | 2.0432.011.7 | 3 | stud bolt m 8 p.1.25 / p.1 x 40 |
| 21 | 2.0432.005.7 | 3 | stud bolt m 8 p.1.5 / p.1 x 25 |
| 25 | 0.014.5260.0/10 | 0.5 | gasket - A - mm 1.4 |
| 26 | 0.014.5259.0/10 | 2 | gasket - B - mm 1.2 |
| 27 | 0.014.5261.0/10 | 0.5 | gasket - C - mm 1.6 |

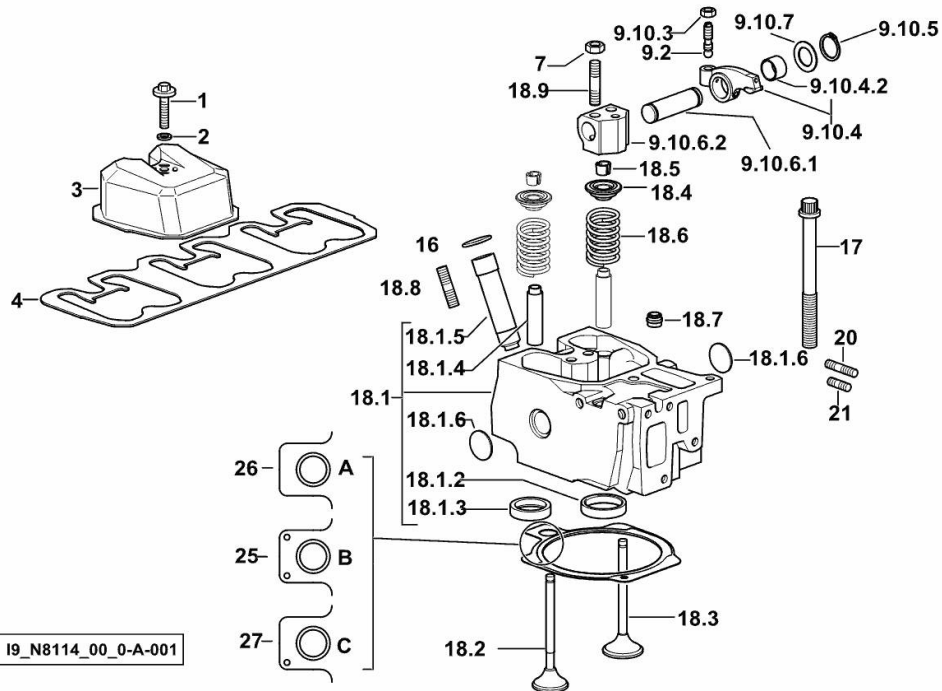

19_N8114_00_0-A-001

Section: B0 - ENGINE
ENGINE OIL PUMP

| Fig. | P/n | QTY | Name |
|------|-----|-----|------|
|------|-----|-----|------|

Notes:

[603 LD 2WD] -> 9960 [603 LD 4WD] -> 9960

| | | | |
|---------|-----------------|---|----------------------------------|
| 35 | 0.065.1560.0/30 | 2 | gasket |
| 36 | 2.0169.005.2 | 2 | screw m 6 p.1 x 12 |
| 37 | 2.1652.711.0 | 2 | cylindrical plug 8x25 |
| 38 | 0.075.1551.4/30 | 1 | support |
| 38.1 | 0.075.1551.3/40 | 1 | support |
| 38.1.2 | 2.1559.186.0 | 1 | special bushing 26 x 31.5 x 35 |
| 38.2 | 2.1219.025.2/10 | 1 | ring nut m 36 p.1.5 |
| 38.3 | 2.1410.057.1 | 1 | circlip 15 |
| 38.4 | 2.1589.153.0 | 1 | shoulder ring 15.2 x 19 x 1.00 |
| 38.5 | 2.1589.146.0 | 2 | shoulder ring 15.2 x 19 x 0.15 |
| 38.6 | 2.1589.147.0 | 2 | shoulder ring 15.2 x 19 x 0.10 |
| 38.7 | 2.2020.001.0 | 1 | ball bearing 15 x 32 x 8.00 |
| 38.8 | 2.1589.148.0 | 1 | shoulder ring 28.2 x 31.8 x 0.5 |
| 38.9 | 2.1589.150.0 | 2 | shoulder ring 28.2 x 31.8 x 0.1 |
| 38.10 | 2.1589.151.0 | 2 | shoulder ring 28.2 x 31.8 x 0.15 |
| 38.11.1 | 0.065.1558.6/10 | 1 | bevel drive |
| 38.11.2 | 0.065.1559.0 | 1 | bush |
| 38.12 | 2.2680.020.0 | 1 | ring 12 x 15 x 12 |
| 38.13 | 2.2725.016.0 | 1 | roller cage 15 x 21 x 12 |
| 38.14 | 2.0342.007.2 | 1 | screw m 4 p.0.7x25 |
| 38.15 | 2.0399.128.2/10 | 1 | screw m 8 p.1 x 8 |
| 38.16 | 2.2030.002.0 | 1 | ball bearing 12 x 28 x 8 |
| 40 | 0.065.1569.0/40 | 1 | shaft |
| 41 | 0.065.1562.0/10 | 1 | joint |
| 42 | 0.014.7994.4 | 1 | oil pump |
| 43 | 2.1470.006.2 | 2 | lock washer 10 |
| 44 | 2.0112.323.2 | 2 | screw m 10 p.1.5x70 |

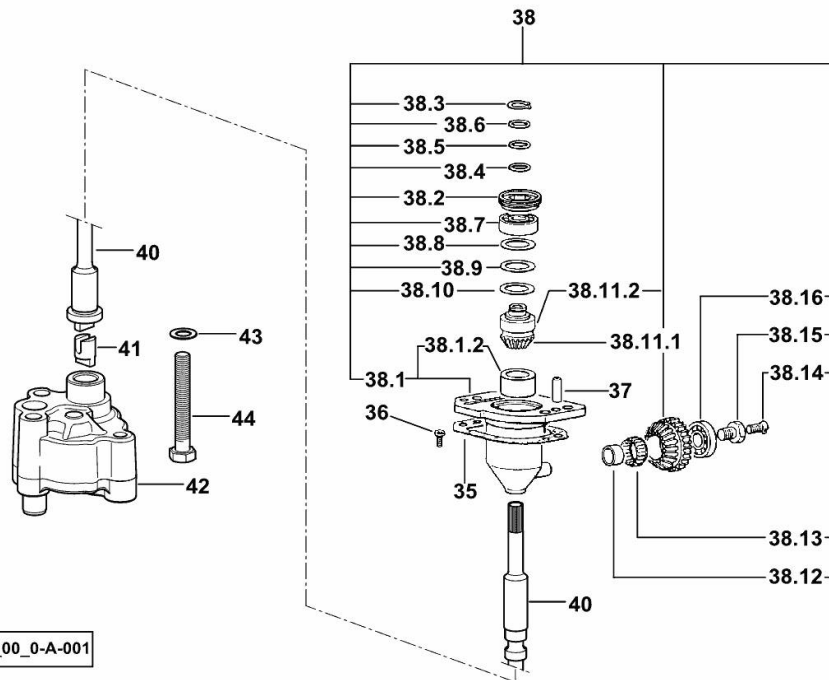

19_38515_00_0-A-001

Section: B0 - ENGINE

ENGINE OIL PUMP

| Fig. | P/n | QTY | Name |
|------|-----|-----|------|
|------|-----|-----|------|

Notes:

- FOR TYPES WITH DOUBLE CLUTCH [603 LD 2WD]

| | | | |
|---------|-----------------|---|----------------------------------|
| 36 | 2.0169.005.2 | 2 | screw m 6 p.1 x 12 |
| 37 | 2.1652.711.0 | 2 | cylindrical plug 8x25 |
| 38 | 0.075.1551.4/30 | 1 | support |
| 38.1 | 0.075.1551.3/40 | 1 | support |
| 38.1.2 | 2.1559.186.0 | 1 | special bushing 26 x 31.5 x 35 |
| 38.2 | 2.1219.025.2/10 | 1 | ring nut m 36 p.1.5 |
| 38.3 | 2.1410.057.1 | 1 | circlip 15 |
| 38.4 | 2.1589.153.0 | 1 | shoulder ring 15.2 x 19 x 1.00 |
| 38.5 | 2.1589.146.0 | 2 | shoulder ring 15.2 x 19 x 0.15 |
| 38.6 | 2.1589.147.0 | 2 | shoulder ring 15.2 x 19 x 0.10 |
| 38.7 | 2.2020.001.0 | 1 | ball bearing 15 x 32 x 8.00 |
| 38.8 | 2.1589.148.0 | 1 | shoulder ring 28.2 x 31.8 x 0.5 |
| 38.9 | 2.1589.150.0 | 2 | shoulder ring 28.2 x 31.8 x 0.1 |
| 38.10 | 2.1589.151.0 | 2 | shoulder ring 28.2 x 31.8 x 0.15 |
| 38.11.1 | 0.065.1558.6/10 | 1 | bevel drive |
| 38.11.2 | 0.065.1559.0 | 1 | bush |
| 38.12 | 2.2680.020.0 | 1 | ring 12 x 15 x 12 |
| 38.13 | 2.2725.016.0 | 1 | roller cage 15 x 21 x 12 |
| 38.14 | 2.0342.007.2 | 1 | screw m 4 p.0.7x25 |
| 38.15 | 2.0399.128.2/10 | 1 | screw m 8 p.1 x 8 |
| 38.16 | 2.2030.002.0 | 1 | ball bearing 12 x 28 x 8 |
| 39 | 0.065.1560.0/30 | 2 | gasket |
| 40 | 0.065.1569.0/40 | 1 | shaft |
| 41 | 0.065.1562.0/10 | 1 | joint |
| 42 | 0.014.7994.4 | 1 | oil pump |
| 43 | 2.1470.006.2 | 2 | lock washer 10 |
| 44 | 2.0112.323.2 | 2 | screw m 10 p.1.5x70 |

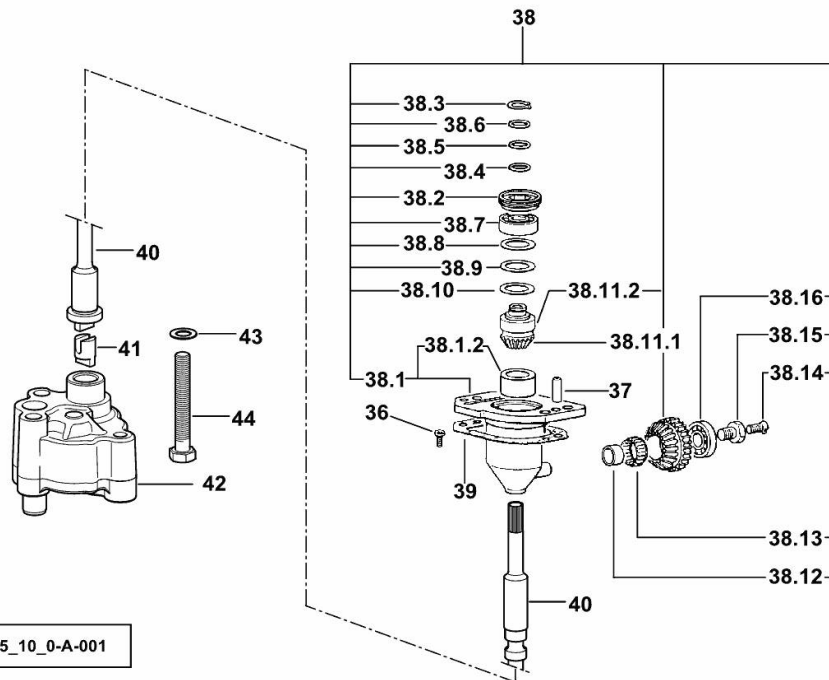

19_38515_10_0-A-001

LUBRICATION

| Fig. | P/n | QTY | Name |
|------|-----|-----|------|
|------|-----|-----|------|

Notes:

[603 LD 2WD] -> 9960 [603 LD 4WD] -> 9960

| | | | |
|--------|-----------------|----|-------------------------------|
| 1 | 0.065.1160.3/20 | 3 | valve |
| 50 | 2.1099.108.2 | 3 | special nut m 10 p.1 |
| 51 | 2.1560.006.0 | 12 | gasket 10.2 x 16 |
| 52 | 0.086.1550.2 | 3 | sprayer nozzle |
| 55 | 2.0312.221.2 | 2 | screw m 8 p.1.25x75 |
| 56 | 2.1480.014.1 | 2 | washer 8 |
| 57 | 0.012.0688.4 | 1 | sediment bowl |
| 57.1 | 0.066.1553.0 | 1 | cover |
| 57.2 | 0.066.1554.0/20 | 1 | gasket |
| 57.3 | 2.0399.304.2 | 4 | screw m 4 x 10 |
| 57.4.1 | 0.066.1555.0 | 1 | tube |
| 57.4.2 | 0.012.0688.0 | 1 | small tank |
| 58 | 2.1532.012.0 | 1 | oil seal 6.75 x 1.78 |
| 59 | 2.1539.072.0 | 2 | special oil seal 23.52 x 1.78 |
| 60 | 0.066.1558.0 | 1 | bush |
| 61 | 0.066.1557.2 | 1 | tube |
| 62 | 2.3350.003.1 | 1 | nosepiece 8 |
| 63 | 2.3339.418.1 | 1 | pipe fitting m 12 p.1 |
| 65 | 0.007.1427.0 | 1 | tube |
| 66 | 0.002.8816.0 | 1 | small plate |
| 67 | 2.0112.007.2 | 1 | screw m 6 p.1 x 20 |
| 68 | 2.1011.103.2 | 1 | nut m 6 p.1 |
| 69 | 2.1470.002.2 | 1 | lock washer 6 |

I9_38515_00_0-C-001

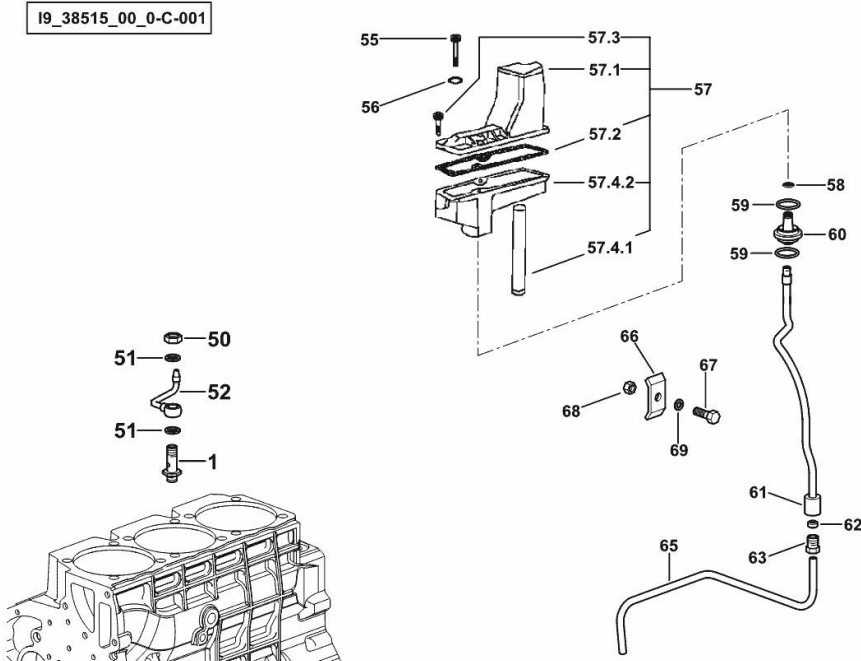

LUBRICATION

| Fig. | P/n | QTY | Name |
|------|-----|-----|------|
|------|-----|-----|------|

Notes:

- FOR TYPES WITH DOUBLE CLUTCH [603 LD 2WD]

| | | | |
|--------|-----------------|----|-------------------------------|
| 1 | 0.065.1160.3/20 | 3 | valve |
| 50 | 2.1099.108.2 | 3 | special nut m 10 p.1 |
| 51 | 2.1560.006.0 | 12 | gasket 10.2 x 16 |
| 52 | 0.086.1550.2 | 3 | sprayer nozzle |
| 55 | 2.0312.221.2 | 2 | screw m 8 p.1.25x75 |
| 56 | 2.1480.014.1 | 2 | washer 8 |
| 57 | 0.012.0688.4 | 1 | sediment bowl |
| 57.1 | 0.066.1553.0 | 1 | cover |
| 57.2 | 0.066.1554.0/20 | 1 | gasket |
| 57.3 | 2.0399.304.2 | 4 | screw m 4 x 10 |
| 57.4.1 | 0.066.1555.0 | 1 | tube |
| 57.4.2 | 0.012.0688.0 | 1 | small tank |
| 58 | 2.1532.012.0 | 1 | oil seal 6.75 x 1.78 |
| 59 | 2.1539.072.0 | 2 | special oil seal 23.52 x 1.78 |
| 60 | 0.066.1558.0 | 1 | bush |
| 61 | 0.066.1557.2 | 1 | tube |
| 62 | 2.3350.003.1 | 1 | nosepiece 8 |
| 63 | 2.3339.418.1 | 1 | pipe fitting m 12 p.1 |
| 65 | 0.069.1550.0 | 1 | tube |
| 66 | 0.075.1552.4 | 1 | bracket |
| 66.1 | 0.075.1552.0 | 1 | bracket |
| 66.2 | 0.075.1552.2 | 1 | bracket |
| 66.3 | 2.1011.103.2 | 1 | nut m 6 p.1 |
| 66.4 | 2.1470.002.2 | 1 | lock washer 6 |

I9_38515_10_0-C-001

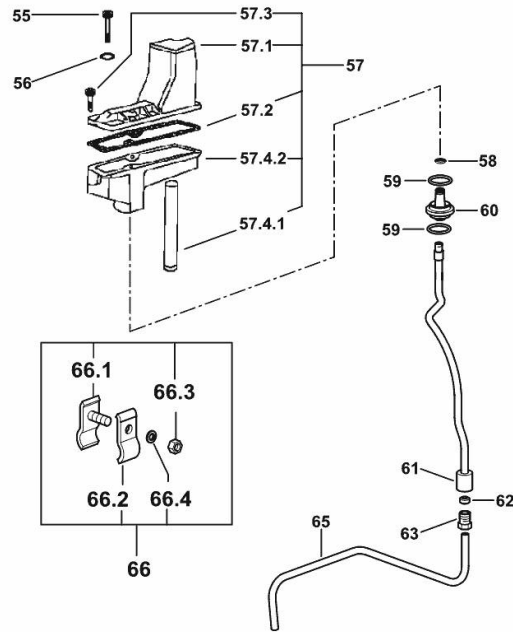
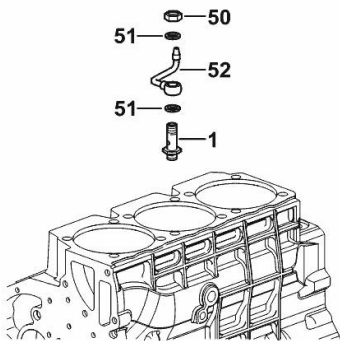

LUBRICATION

| Fig. | P/n | QTY | Name |
|------|-----|-----|------|
|------|-----|-----|------|

Notes:

[603 LD 2WD] -> 9960 [603 LD 4WD] -> 9960

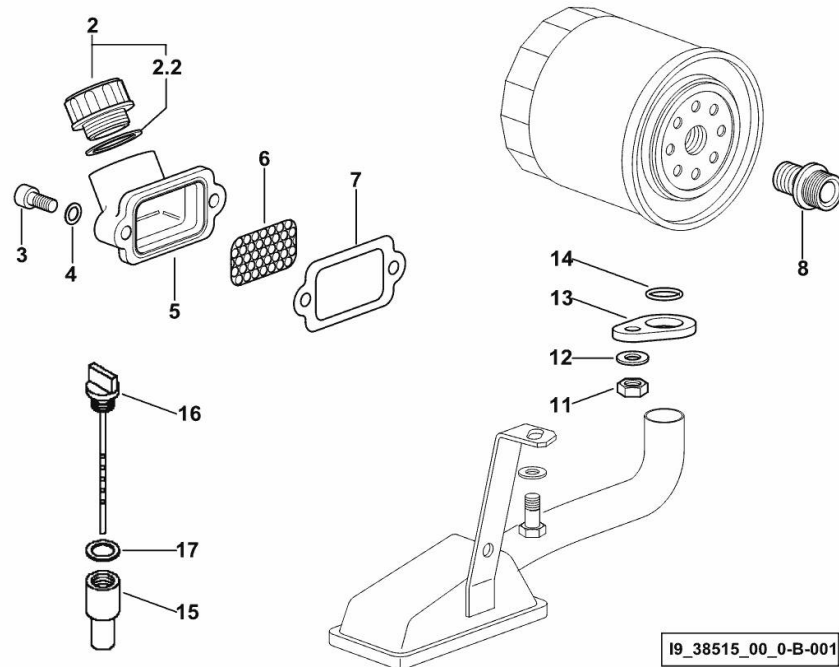

| | | | |
|-----|-----------------|---|-------------------------------|
| 2 | 0.041.1135.4 | 1 | plug 1" gas |
| 2.2 | 2.1569.072.0 | 1 | gasket 32 x 39.5 x 2 |
| 3 | 2.0312.205.2 | 2 | screw |
| 4 | 2.1480.014.1 | 2 | washer 8 |
| 5 | 0.012.0613.0 | 1 | pipe union |
| 6 | 0.065.1567.0/10 | 1 | filter |
| 7 | 0.065.1566.0 | 1 | gasket |
| 8 | 2.3339.307.0 | 1 | pipe fitting m 22 p.1.5-3/4" |
| 11 | 2.1011.105.2 | 1 | nut m 8 p.1.25 |
| 12 | 2.1470.004.2 | 1 | lock washer 8 |
| 13 | 0.065.1538.0 | 1 | flange |
| 14 | 2.1539.040.0 | 1 | special oil seal 21.82 x 3.53 |
| 15 | 0.012.0684.0 | 1 | none |
| 16 | 0.012.0682.2 | 1 | dipstick |
| 17 | 2.1539.065.0 | 1 | special oil seal 8.73 x 1.78 |

I9_38515_00_0-B-001

LUBRICATION

| Fig. | P/n | QTY | Name |
|------|-----|-----|------|
|------|-----|-----|------|

Notes:

- FOR TYPES WITH DOUBLE CLUTCH [603 LD 2WD]

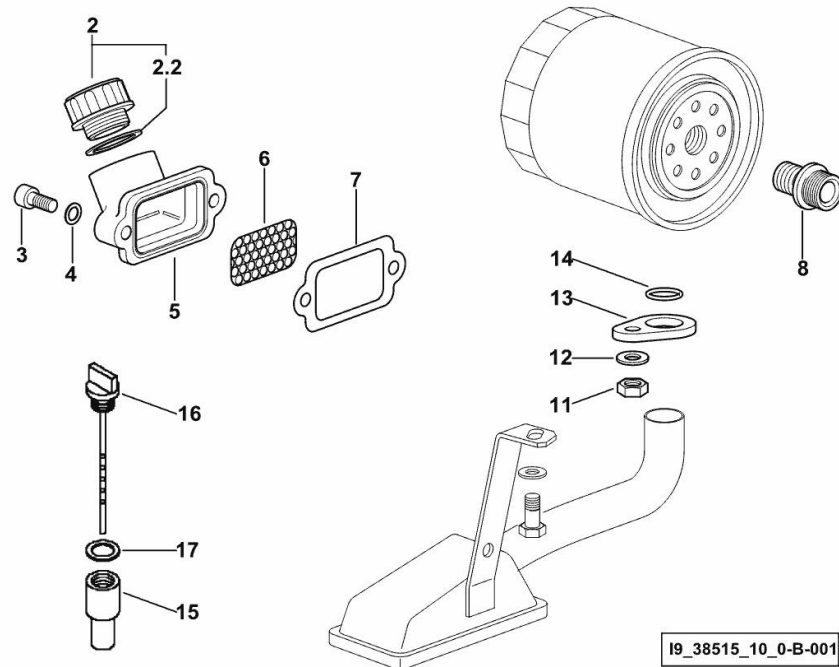

| | | | |
|-----|-----------------|---|-------------------------------|
| 2 | 0.041.1135.4 | 1 | plug 1" gas |
| 2.2 | 2.1569.072.0 | 1 | gasket 32 x 39.5 x 2 |
| 3 | 2.0312.205.2 | 2 | screw |
| 4 | 2.1480.014.1 | 2 | washer 8 |
| 5 | 0.012.0613.0 | 1 | pipe union |
| 6 | 0.065.1567.0/10 | 1 | filter |
| 7 | 0.065.1566.0 | 1 | gasket |
| 8 | 2.3339.307.0 | 1 | pipe fitting m 22 p.1.5-3/4" |
| 11 | 2.1011.105.2 | 1 | nut m 8 p.1.25 |
| 12 | 2.1470.004.2 | 1 | lock washer 8 |
| 13 | 0.065.1538.0 | 1 | flange |
| 14 | 2.1539.040.0 | 1 | special oil seal 21.82 x 3.53 |
| 15 | 0.012.0684.0 | 1 | none |
| 16 | 0.012.0682.2 | 1 | dipstick |
| 17 | 2.1539.065.0 | 1 | special oil seal 8.73 x 1.78 |

Thank you so much for reading.
Please click the “Buy Now!”
button below to download the
complete manual.



After you pay.

You can download the most
perfect and complete manual in
the world immediately.

Our support email:

ebooklibonline@outlook.com