

FRAME SHROUDING & ATTACHING PARTS, RIGHT SIDE

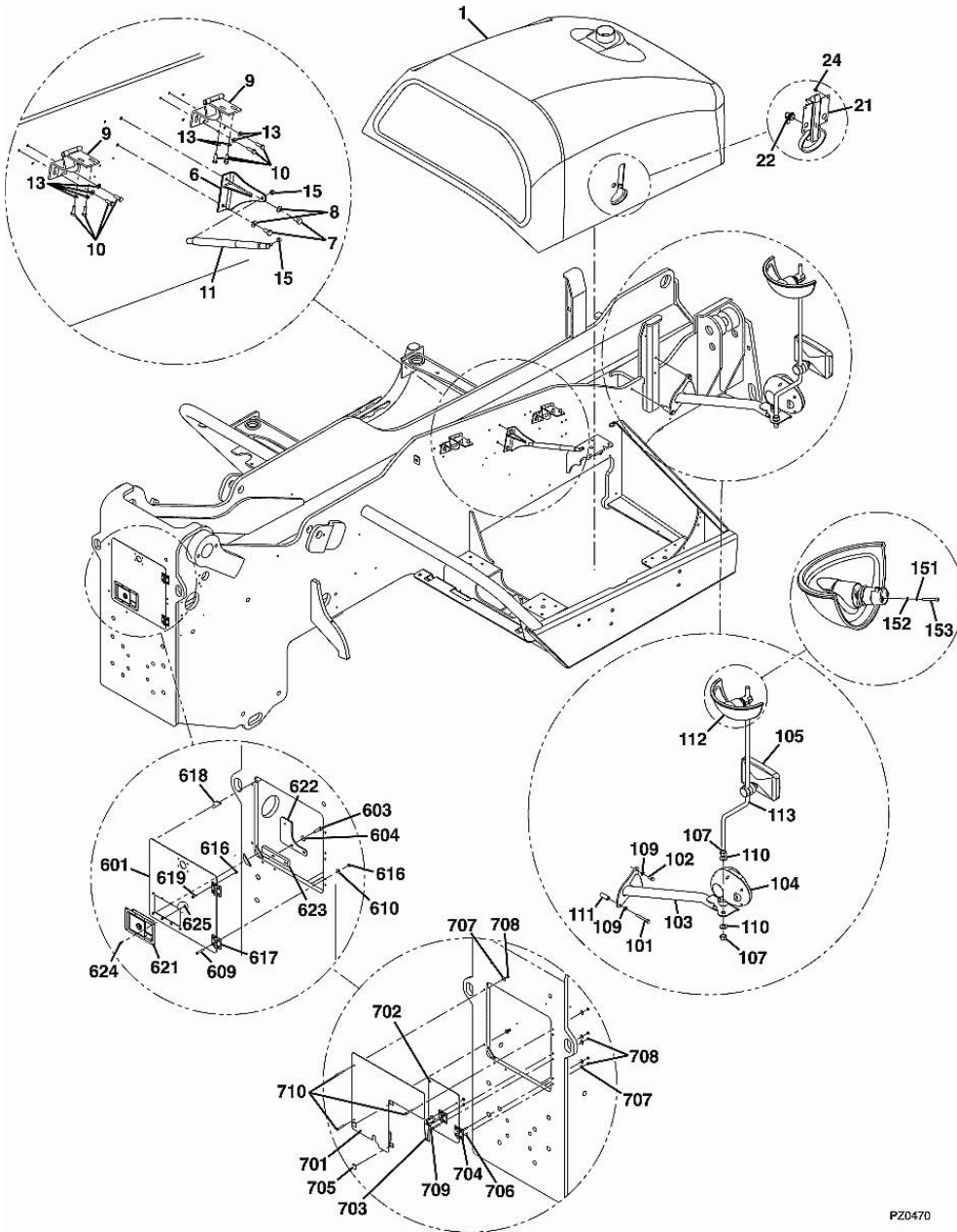

P20470

Fig.	P/n	QTY	Name
Notes:			
[Agrovector 40.9]			
1	0.900.1137.0	1	hood kpl. INCLUDES ITEMS 21 THRU 24
6	0.900.1049.9	1	bracket
7	0.900.0155.9	2	screw m 10 p.1.5 x 20
8	0.900.0201.4	2	washer 10.5
9	0.900.0200.6	2	hinge
10	0.900.0155.5	2	screw m 8 p.1.25 x 25
11	0.900.0245.5	1	spring
13	0.900.0201.3	8	washer 8
15	0.900.0182.7	2	nut m 8 p.1.25
21	0.900.0245.4	1	small plate
22	0.900.0245.8	1	interlock
23	0.900.0165.1		gasket NOT SHOWN
24	0.900.0938.5	3	nut
101	0.900.1004.3	1	screw m 10 p.1.5 x 80
102	0.900.0156.1	2	screw m 10 p.1.5 x 25
103	0.900.1136.1	1	bracket dx/rh/re
104	0.000.0000.1		cannot be supplied INCLUDES MOUNTING HARDWARE ☞ 3A.00.5
105	0.900.0420.9	1	mirror
107	0.900.0183.4	2	nut m 20 p.2.25
109	0.900.0201.4	3	washer 10.5
110	0.900.0201.7	2	washer 20
111	0.900.1093.4	1	tube
112	0.900.1008.4	1	rear view mirror kpl. INCLUDES ITEMS 151 THRU 153
113	0.900.1016.6	1	support
151	0.900.1008.5	2	washer # 12
152	0.900.1008.6	2	washer
153	0.900.1136.5	2	bolt
251	0.900.0154.9	7	screw m 6 p.1 x 16
252	0.900.1006.3	1	bracket
253	0.900.1006.4	1	bracket
254	0.900.1006.5	1	support
255	0.900.1025.9		lining
256	0.900.1139.6	1	panel
257	0.900.1139.2	1	panel kpl.
258	0.900.0890.0	2	screw
259	0.900.1059.9	1	bolt m 8 x 25

FRAME SHROUDING & ATTACHING PARTS, RIGHT SIDE

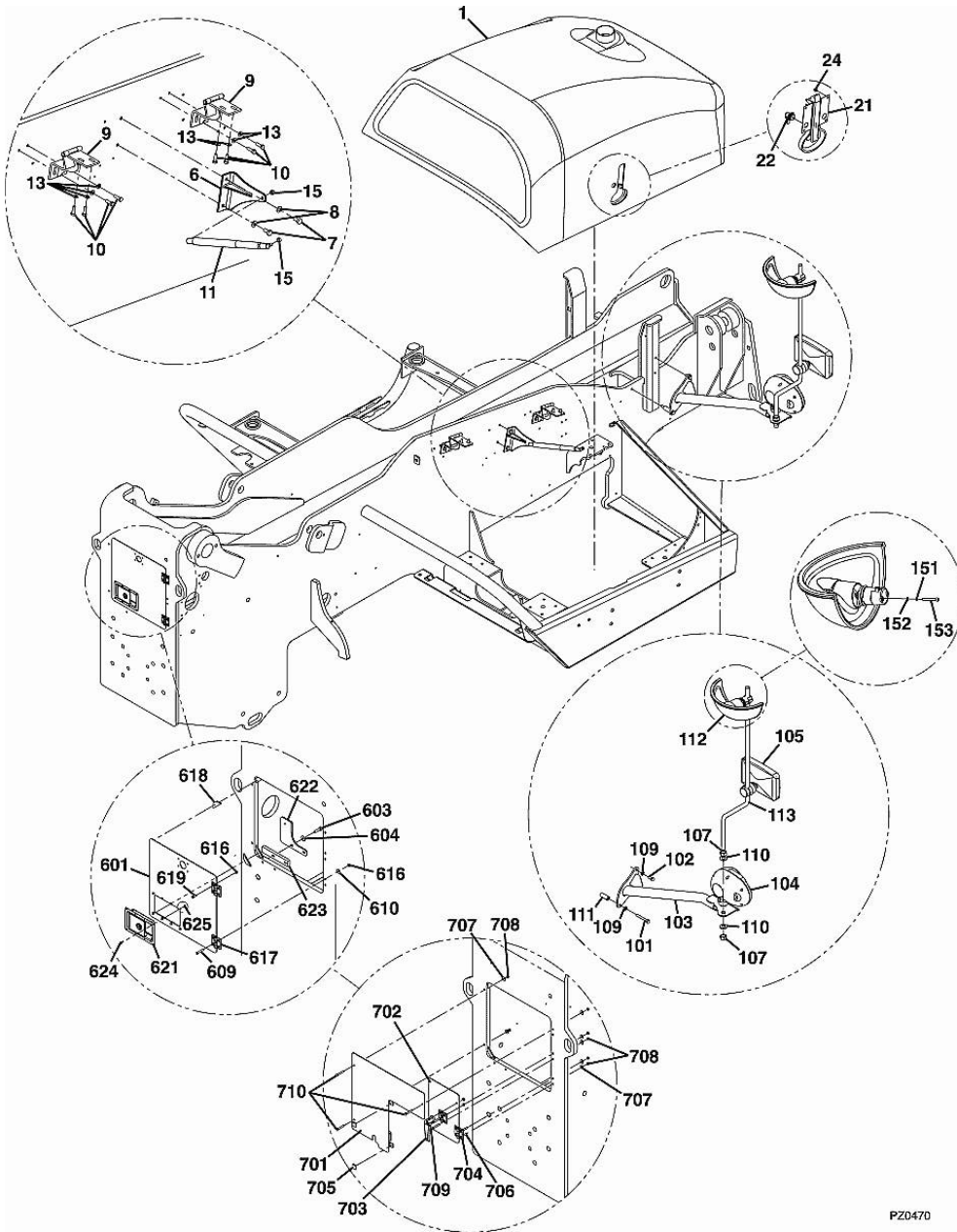

P20470

Fig.	P/n	QTY	Name
260	0.900.0203.3	12	washer 6, d128
262	0.900.0203.6	1	nut m 8
263	0.900.0155.0	3	screw m 6 x 20
264	0.900.0155.1	2	screw m 6 x 25
351	0.900.1004.6	2	screw m 4 x 41
352	0.900.1041.0	2	nut m 4 p.0.7
353	0.900.1145.9	1	plate
354	0.900.1053.8	1	tank
355	0.900.0431.3	2	washer 4
356	0.900.1060.2	2	bolt
357	0.900.1094.1	1	plate
358	0.000.0000.1		cannot be supplied ☞ 38.00.0
401	0.000.0000.1		cannot be supplied ☞ 3A.00.3
402	0.000.0000.1		cannot be supplied ☞ 3A.00.3
501	0.900.1135.8	1	support sx/lh/li
502	0.900.1135.9	1	support dx/rh/re
503	0.000.0000.1		cannot be supplied ☞ 3A.00.5
504	0.000.0000.1		cannot be supplied ☞ 3A.00.5
505	0.900.0201.3	4	washer 8
506	0.900.0182.7	4	nut m 8 p.1.25
507	0.900.0203.5	4	washer 10.2
508	0.900.0156.1	4	screw m 10 p.1.5 x 25
509	0.900.0162.4	4	washer
510	0.900.0153.8	2	screw 1.75x55
511	0.900.0183.2	2	nut 1.75x12
512	0.900.0251.4	2	rubber buffer
513	0.900.0251.0	2	plate
601	0.900.1137.5	1	rear panel
603	0.900.0155.6	2	screw m 8 p.1.5 x 30
604	0.900.0203.4	2	washer 8
609	0.900.0249.4	4	screw m 6 p.1 x 40
610	0.900.0203.3	4	washer 6, d128
616	0.900.0182.4	8	nut
617	0.900.0249.3	2	hinge
618	0.900.0253.5		gasket 0.12 m
619	0.900.0152.0	4	screw m 6 x 20 40 mm
621	0.900.0925.0	1	cover

FRAME SHROUDING & ATTACHING PARTS, RIGHT SIDE

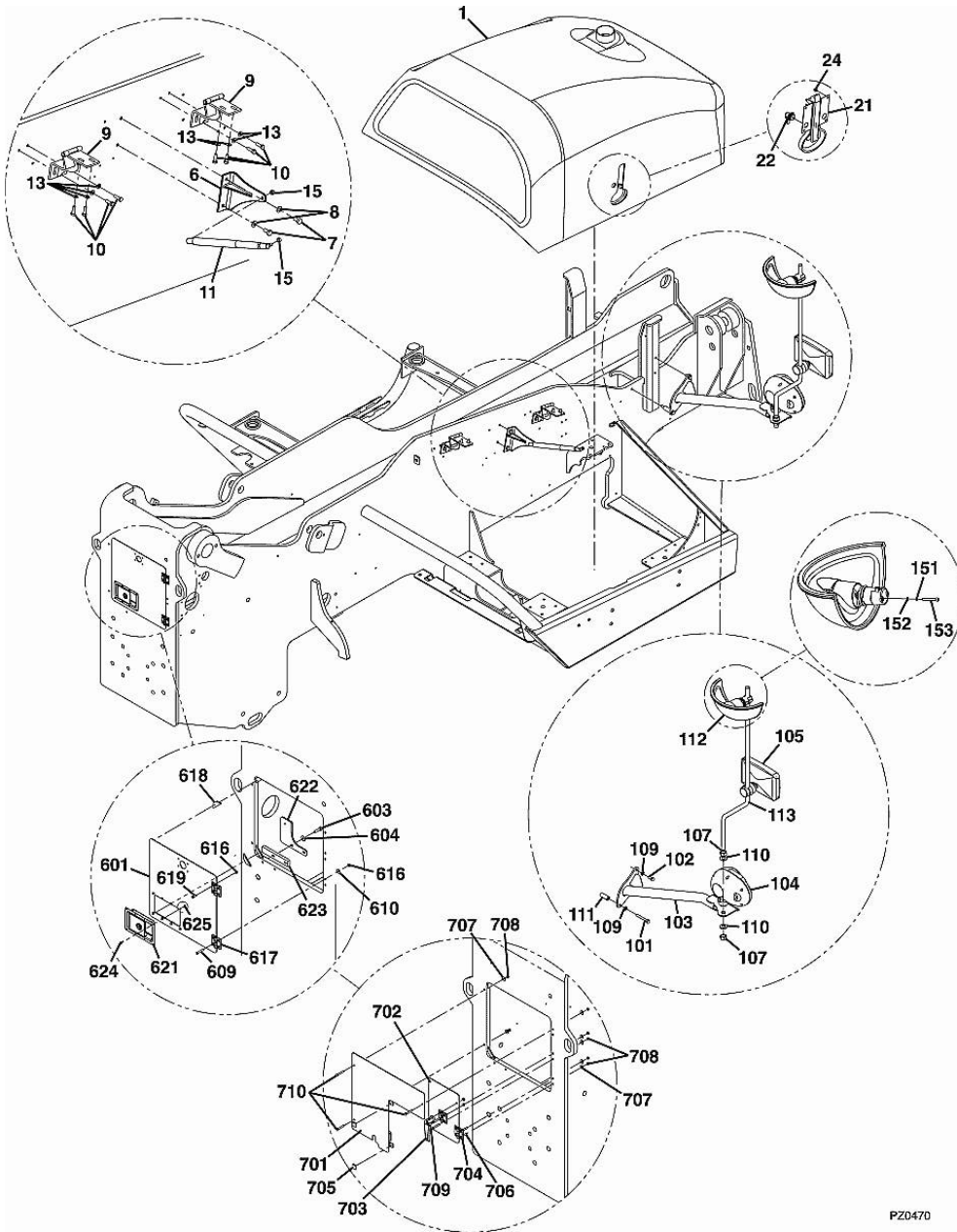
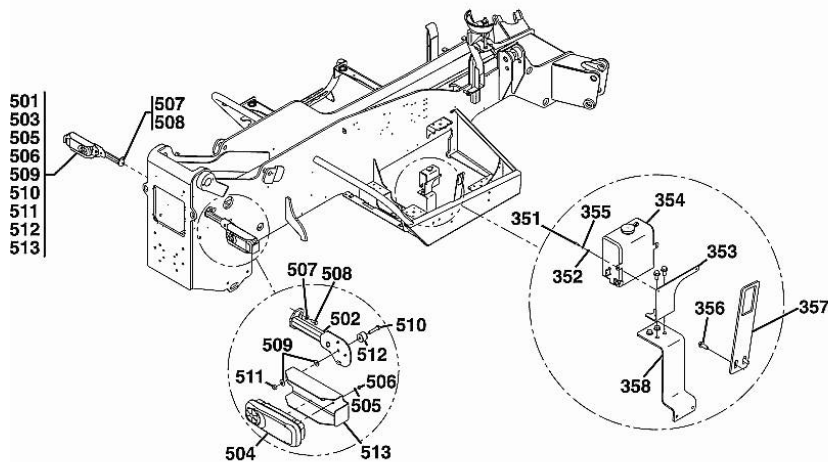
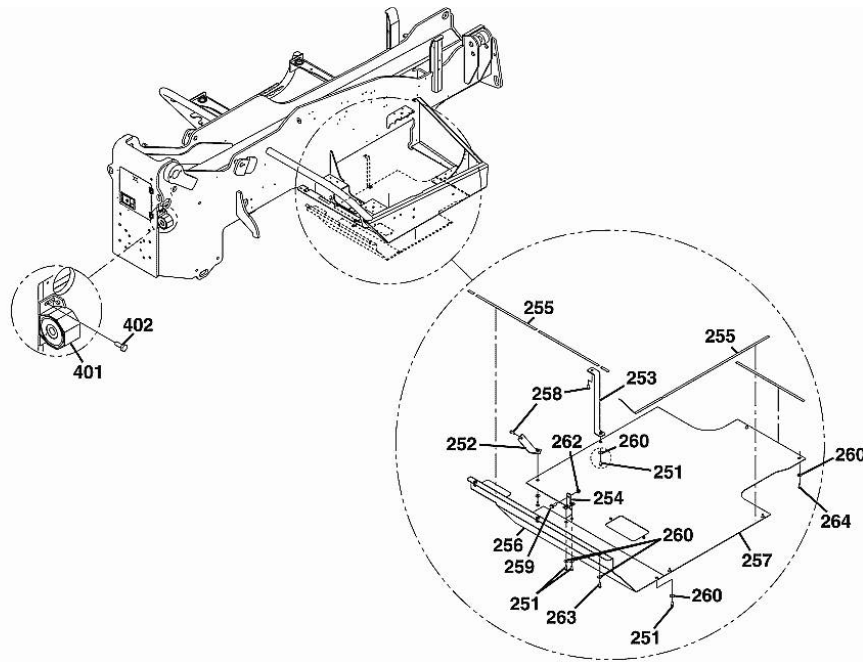

Fig.	P/n	QTY	Name
622	0.900.0924.8	1	0.6 m bracket
623	0.900.0924.9	1	1.05 m spacer
624	0.900.1018.7	8	0.8 m screw m 5 p.0.8 x 10
625	0.900.0929.0	8	0.9 m nut m5x0.8
626	0.000.0000.1		2.5 m cannot be supplied NOT SHOWN ☞ 3A.00.5
701	0.900.1145.2	1	panel
702	0.900.1145.3	1	door
703	0.900.1039.7	1	handle L
704	0.900.0249.3	2	hinge
705	0.900.0253.5		gasket 40 mm
706	0.900.0249.4	4	screw m 6 p.1 x 40
707	0.900.0203.3	7	washer 6, d128
708	0.900.0182.4	11	nut
709	0.900.0152.0	4	screw m 6 x 20
710	0.900.0152.6	3	screw m 6 p.1x40
999	0.000.0000.1		cannot be supplied

FRAME SHROUDING & ATTACHING PARTS, RIGHT SIDE



P22420

Fig.	P/n	QTY	Name
Notes:			
[Agrovector 40.9]			
1	0.900.1137.0	1	hood kpl. INCLUDES ITEMS 21 THRU 24
6	0.900.1049.9	1	bracket
7	0.900.0155.9	2	screw m 10 p.1.5 x 20
8	0.900.0201.4	2	washer 10.5
9	0.900.0200.6	2	hinge
10	0.900.0155.5	2	screw m 8 p.1.25 x 25
11	0.900.0245.5	1	spring
13	0.900.0201.3	8	washer 8
15	0.900.0182.7	2	nut m 8 p.1.25
21	0.900.0245.4	1	small plate
22	0.900.0245.8	1	interlock
23	0.900.0165.1		gasket NOT SHOWN
24	0.900.0938.5	3	nut
101	0.900.1004.3	1	screw m 10 p.1.5 x 80
102	0.900.0156.1	2	screw m 10 p.1.5 x 25
103	0.900.1136.1	1	bracket dx/rh/re
104	0.000.0000.1		cannot be supplied INCLUDES MOUNTING HARDWARE ☞ 3A.00.5
105	0.900.0420.9	1	mirror
107	0.900.0183.4	2	nut m 20 p.2.25
109	0.900.0201.4	3	washer 10.5
110	0.900.0201.7	2	washer 20
111	0.900.1093.4	1	tube
112	0.900.1008.4	1	rear view mirror kpl. INCLUDES ITEMS 151 THRU 153
113	0.900.1016.6	1	support
151	0.900.1008.5	2	washer # 12
152	0.900.1008.6	2	washer
153	0.900.1136.5	2	bolt
251	0.900.0154.9	7	screw m 6 p.1 x 16
252	0.900.1006.3	1	bracket
253	0.900.1006.4	1	bracket
254	0.900.1006.5	1	support
255	0.900.1025.9		lining
256	0.900.1139.6	1	panel
257	0.900.1139.2	1	panel kpl.
258	0.900.0890.0	2	screw
259	0.900.1059.9	1	bolt m 8 x 25

FRAME SHROUDING & ATTACHING PARTS, RIGHT SIDE

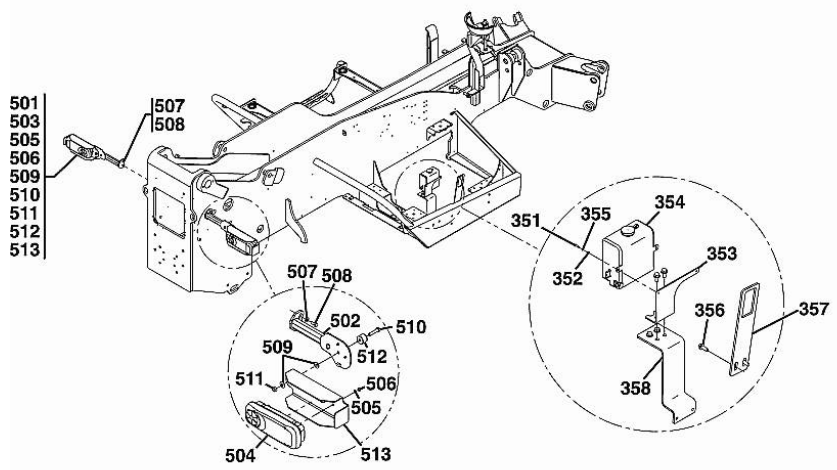
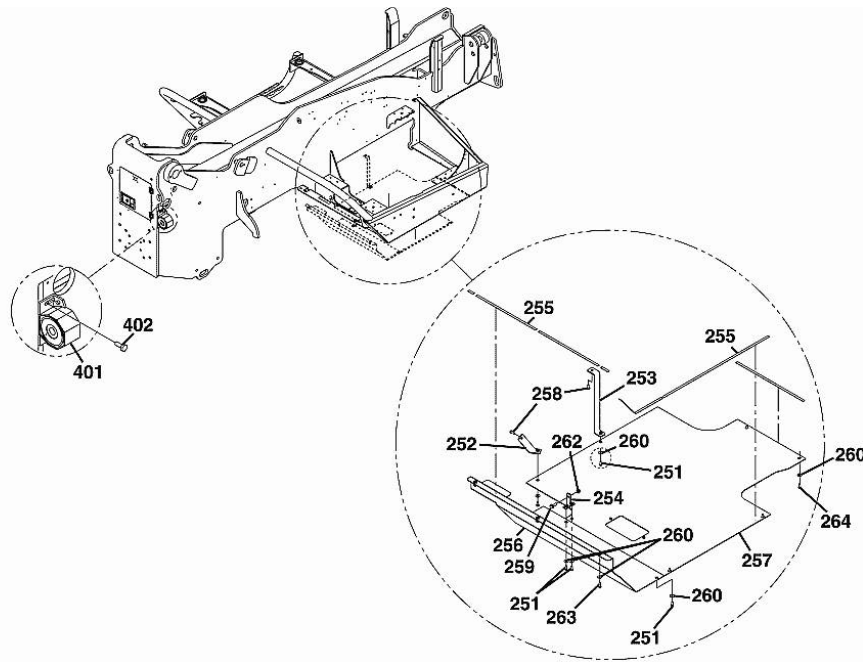

Fig.	P/n	QTY	Name
260	0.900.0203.3	12	washer 6, d128
262	0.900.0203.6	1	nut m 8
263	0.900.0155.0	3	screw m 6 x 20
264	0.900.0155.1	2	screw m 6 x 25
351	0.900.1004.6	2	screw m 4 x 41
352	0.900.1041.0	2	nut m 4 p.0.7
353	0.900.1145.9	1	plate
354	0.900.1053.8	1	tank
355	0.900.0431.3	2	washer 4
356	0.900.1060.2	2	bolt
357	0.900.1094.1	1	plate
358	0.000.0000.1		cannot be supplied ☞ 38.00.0
401	0.000.0000.1		cannot be supplied ☞ 3A.00.3
402	0.000.0000.1		cannot be supplied ☞ 3A.00.3
501	0.900.1135.8	1	support sx/lh/li
502	0.900.1135.9	1	support dx/rh/re
503	0.000.0000.1		cannot be supplied ☞ 3A.00.5
504	0.000.0000.1		cannot be supplied ☞ 3A.00.5
505	0.900.0201.3	4	washer 8
506	0.900.0182.7	4	nut m 8 p.1.25
507	0.900.0203.5	4	washer 10.2
508	0.900.0156.1	4	screw m 10 p.1.5 x 25
509	0.900.0162.4	4	washer
510	0.900.0153.8	2	screw 1.75x55
511	0.900.0183.2	2	nut 1.75x12
512	0.900.0251.4	2	rubber buffer
513	0.900.0251.0	2	plate
601	0.900.1137.5	1	rear panel
603	0.900.0155.6	2	screw m 8 p.1.5 x 30
604	0.900.0203.4	2	washer 8
609	0.900.0249.4	4	screw m 6 p.1 x 40
610	0.900.0203.3	4	washer 6, d128
616	0.900.0182.4	8	nut
617	0.900.0249.3	2	hinge
618	0.900.0253.5		gasket 0.12 m
619	0.900.0152.0	4	screw m 6 x 20 40 mm
621	0.900.0925.0	1	cover

P22420

FRAME SHROUDING & ATTACHING PARTS, RIGHT SIDE

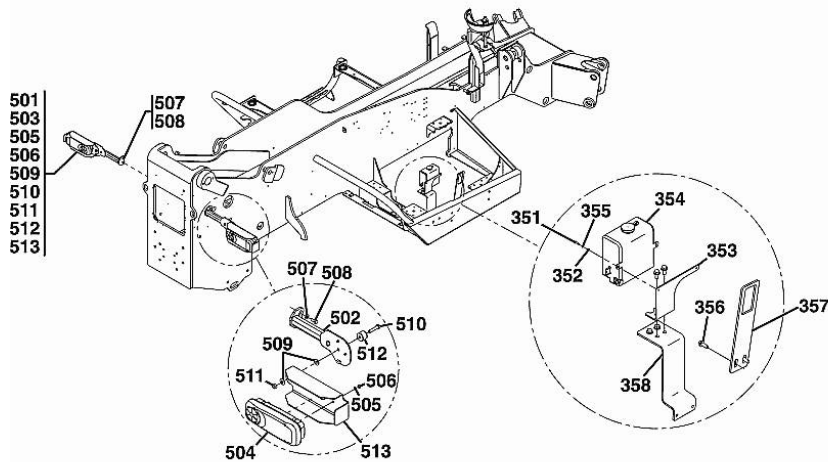
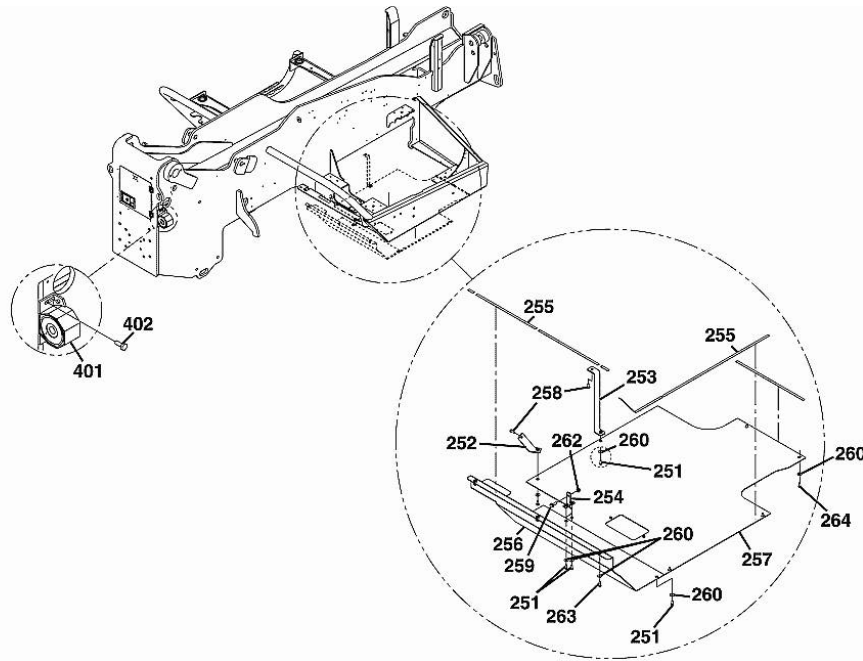
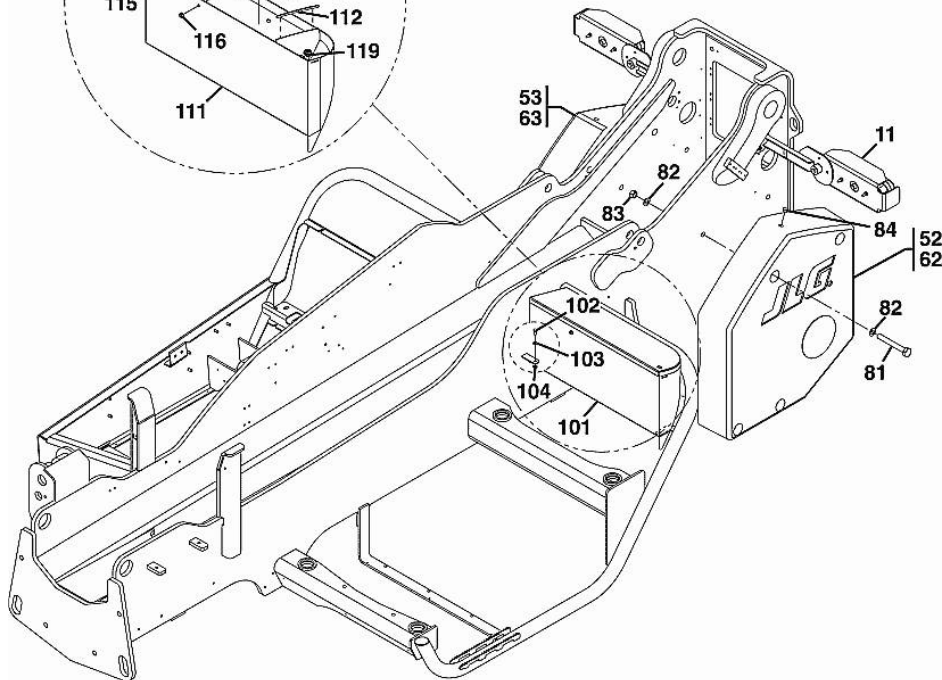
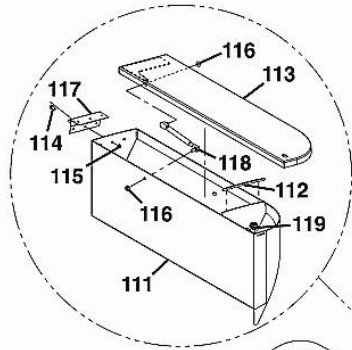
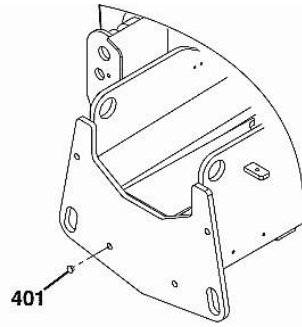

Fig.	P/n	QTY	Name
622	0.900.0924.8	1	0.6 m bracket
623	0.900.0924.9	1	1.05 m spacer
624	0.900.1018.7	8	0.8 m screw m 5 p.0.8 x 10
625	0.900.0929.0	8	0.9 m nut m5x0.8
626	0.000.0000.1		2.5 m cannot be supplied NOT SHOWN ☞ 3A.00.5
701	0.900.1145.2	1	panel
702	0.900.1145.3	1	door
703	0.900.1039.7	1	handle L
704	0.900.0249.3	2	hinge
705	0.900.0253.5		gasket 40 mm
706	0.900.0249.4	4	screw m 6 p.1 x 40
707	0.900.0203.3	7	washer 6, d128
708	0.900.0182.4	11	nut
709	0.900.0152.0	4	screw m 6 x 20
710	0.900.0152.6	3	screw m 6 p.1x40
999	0.000.0000.1		cannot be supplied

FRAME SHROUDING & ATTACHING PARTS, LEFT SIDE



PZ2400

Fig.	P/n	QTY	Name
Notes: [Agrovector 40.9]			
11	0.000.0000.1		cannot be supplied ☞ 3A.00.5
52	0.900.1150.9	1	counterweight LEFT
53	0.900.1151.0	1	counterweight RIGHT
62	0.900.1150.7	1	counterweight LEFT
63	0.900.1150.8	1	counterweight RIGHT
81	0.900.1004.4	8	screw m 20 p.2.5 x 200
82	0.900.0201.7	16	washer 20
83	0.900.1041.3	8	nut m 20
84	0.900.1104.7	2	cap
101	0.900.1135.0	1	toolbox kpl. INCLUDES ITEMS 111 THRU 119
102	0.900.0155.4	3	screw m 8 p.1.25 x 20
103	0.900.0798.5	3	washer
104	0.900.0203.6	3	nut m 8
111	0.900.1135.1	1	implements
112	0.900.1040.5	1	rubber
113	0.900.1145.4	1	cover
114	0.900.0890.0	3	screw
115	0.900.1060.7	6	rivet mm 6
116	0.900.0203.6	2	nut m 8
117	0.900.1095.6	1	hinge
118	0.900.1151.1	1	shock absorber
119	0.900.1103.7	1	lock
201	0.000.0000.1		cannot be supplied ☞ 36.00.0
202	0.900.1025.9		lining
203	0.900.1094.0		gasket 0.6 m
205	0.900.0192.2		rubber
206	0.900.0890.0	6	screw
207	0.900.1042.1	1	guard
401	0.900.1103.8	4	cap PVC
501	0.900.0252.7	1	support
502	0.900.0252.8	1	support
503	0.900.1040.0	4	tube
504	0.900.1060.0	4	bolt m 8 x 30

FRAME SHROUDING & ATTACHING PARTS, LEFT SIDE

Fig.	P/n	QTY	Name
999	0.000.0000.1		cannot be supplied

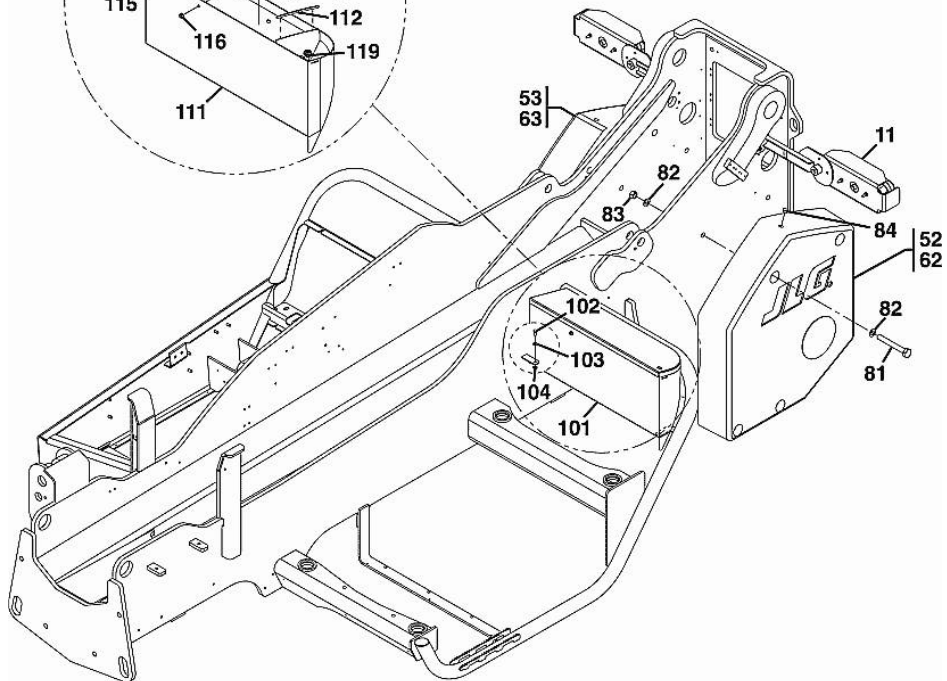
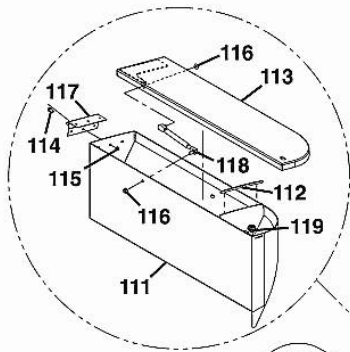
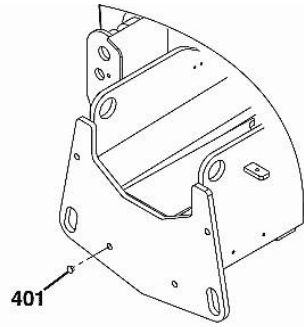

FRAME SHROUDING & ATTACHING PARTS, LEFT SIDE

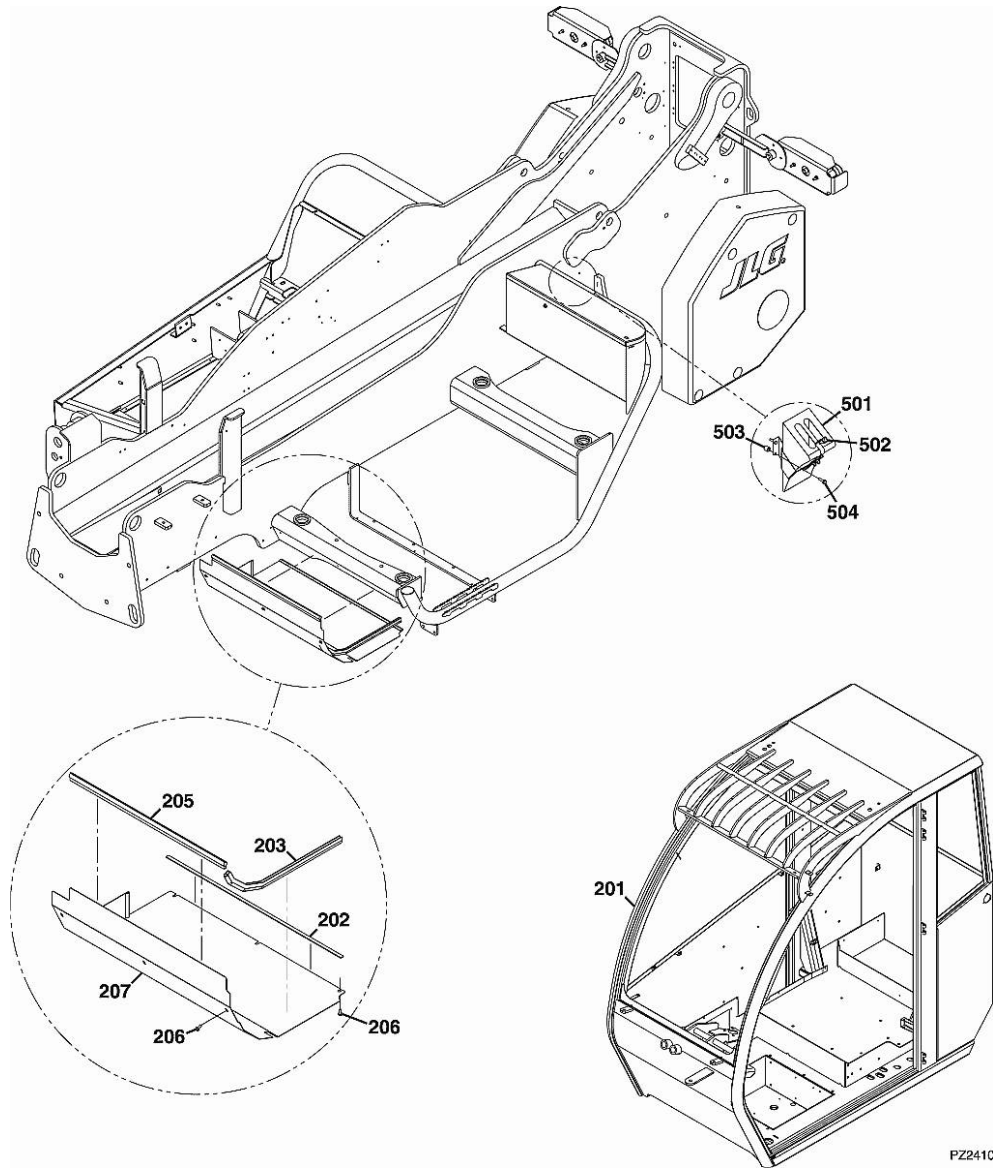
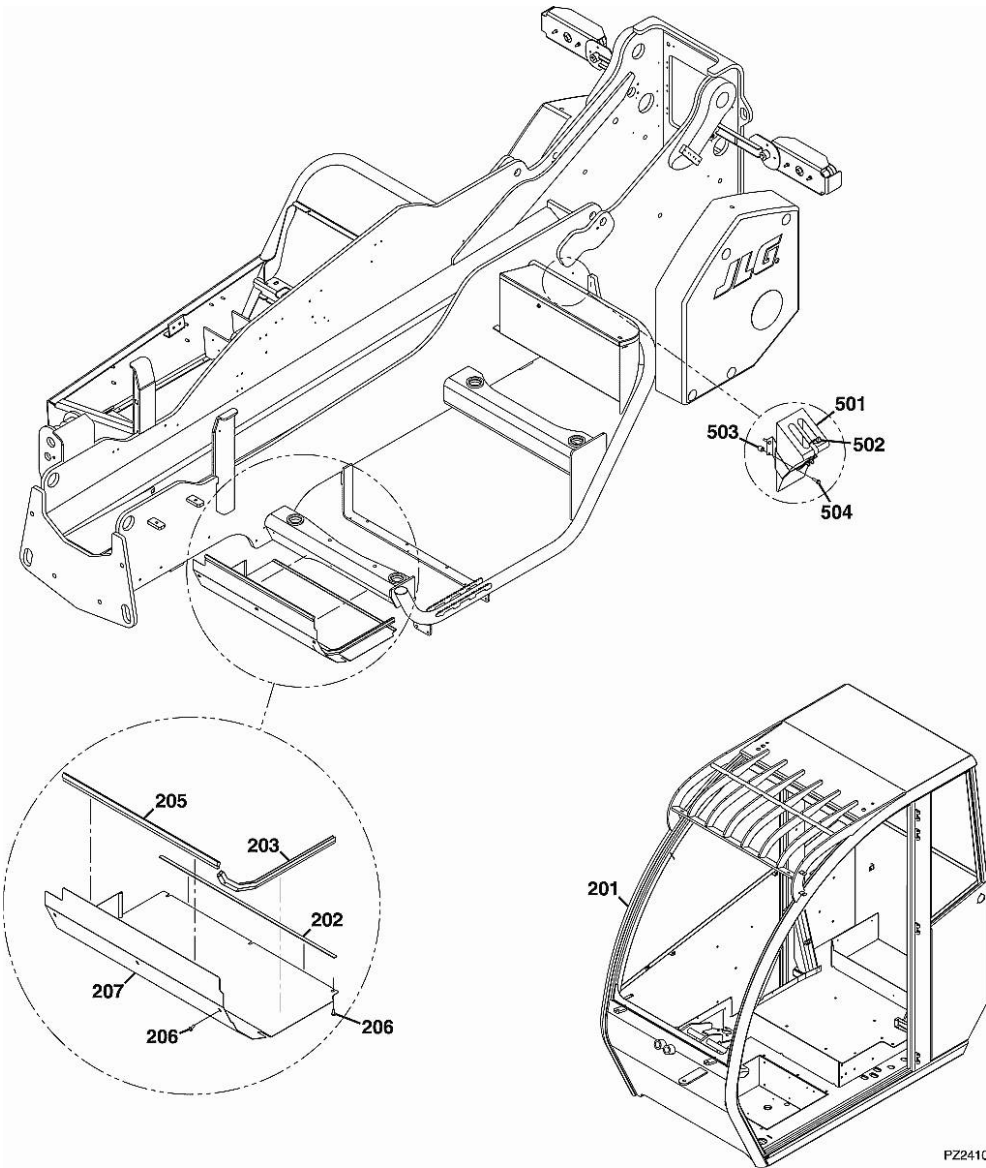

Fig.	P/n	QTY	Name
Notes:			
[Agrovector 40.9]			
11	0.000.0000.1		cannot be supplied ☞ 3A.00.5
52	0.900.1150.9	1	counterweight LEFT
53	0.900.1151.0	1	counterweight RIGHT
62	0.900.1150.7	1	counterweight LEFT
63	0.900.1150.8	1	counterweight RIGHT
81	0.900.1004.4	8	screw m 20 p.2.5 x 200
82	0.900.0201.7	16	washer 20
83	0.900.1041.3	8	nut m 20
84	0.900.1104.7	2	cap
101	0.900.1135.0	1	toolbox kpl. INCLUDES ITEMS 111 THRU 119
102	0.900.0155.4	3	screw m 8 p.1.25 x 20
103	0.900.0798.5	3	washer
104	0.900.0203.6	3	nut m 8
111	0.900.1135.1	1	implements
112	0.900.1040.5	1	rubber
113	0.900.1145.4	1	cover
114	0.900.0890.0	3	screw
115	0.900.1060.7	6	rivet mm 6
116	0.900.0203.6	2	nut m 8
117	0.900.1095.6	1	hinge
118	0.900.1151.1	1	shock absorber
119	0.900.1103.7	1	lock
201	0.000.0000.1		cannot be supplied ☞ 36.00.0
202	0.900.1025.9		lining
203	0.900.1094.0		gasket 0.6 m
205	0.900.0192.2		rubber
206	0.900.0890.0	6	screw
207	0.900.1042.1	1	guard
401	0.900.1103.8	4	cap PVC
501	0.900.0252.7	1	support
502	0.900.0252.8	1	support
503	0.900.1040.0	4	tube
504	0.900.1060.0	4	bolt m 8 x 30

FRAME SHROUDING & ATTACHING PARTS, LEFT SIDE

Fig.	P/n	QTY	Name
999	0.000.0000.1		cannot be supplied



PZ2410

Section: FRAME & ATTACHING PARTS
AXLE & FENDER INSTALLATION

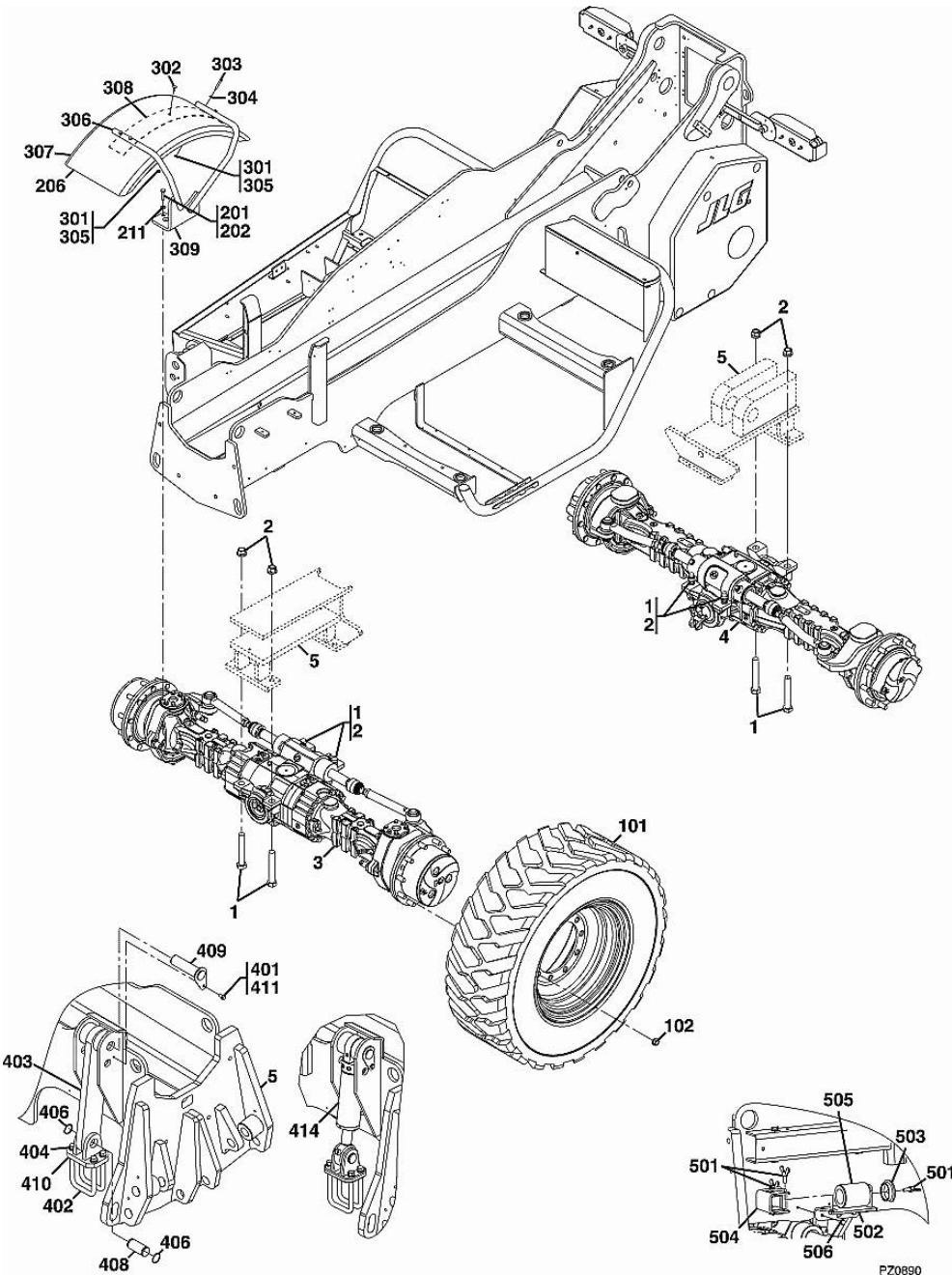

Fig.	P/n	QTY	Name
Notes: [Agrovector 40.9]			
1	0.900.1003.6	8	screw
2	0.900.0183.5	8	nut m 20 p.1.5
3	0.000.0000.1		FRONT AXLE, TORQUE TO 550-600 NM; REAR AXLE, TORQUE TO 550-660 NM cannot be supplied ☞ 35.00.0
4	0.000.0000.1		cannot be supplied ☞ 35.00.5
5	0.000.0000.1		cannot be supplied ☞ 31.00.0
101	0.000.0000.1		cannot be supplied ☞ 35.00.11
102	0.000.0000.1		cannot be supplied ☞ 35.00.11
201	0.900.0148.9		loctite # 242
202	0.900.1003.5	16	screw
211	0.900.1056.6	16	washer m 12
301	0.900.0148.9		loctite # 242
302	0.900.0421.1	1	bolt 1.25 x 20
303	0.900.0923.8	4	screw m 8 p.1.25x50
304	0.900.0201.3	4	washer 8
305	0.900.0203.6	5	nut m 8
306	0.900.0249.6	2	plug
307	0.900.1105.6	1	fender
308	0.900.0252.2	1	support
309	0.900.1105.7	1	support sx/lh/li LEFT, (NOT SHOWN
310	0.900.1105.8	1	support dx/rh/re RIGHT
401	0.900.0148.9		loctite # 242
402	0.000.0000.1		cannot be supplied ☞ 35.00.0
403	0.900.1135.6	1	bracket
404	0.000.0000.1		cannot be supplied ☞ 35.00.0
406	0.900.1044.1	2	ring
408	0.900.1057.3	1	pin
409	0.900.1057.4	1	pin
410	0.000.0000.1		cannot be supplied ☞ 35.00.0
411	0.900.1060.4	1	bolt m 12 x 20

Thank you so much for reading.
Please click the “Buy Now!”
button below to download the
complete manual.



After you pay.

You can download the most
perfect and complete manual in
the world immediately.

Our support email:

ebooklibonline@outlook.com