

ENGINE TYPE-APPROVAL DATA PLATE

Fig.	P/n	QTY	Name
------	-----	-----	------

Notes:
 [DORADO³ 60 -> ZKDR3802W0TS01001]

1	0.000.0000.1		cannot be supplied MADE BY TREVIGLIO ITALY
2	0.000.0000.1		cannot be supplied MADE AT RANIPET - INDIA

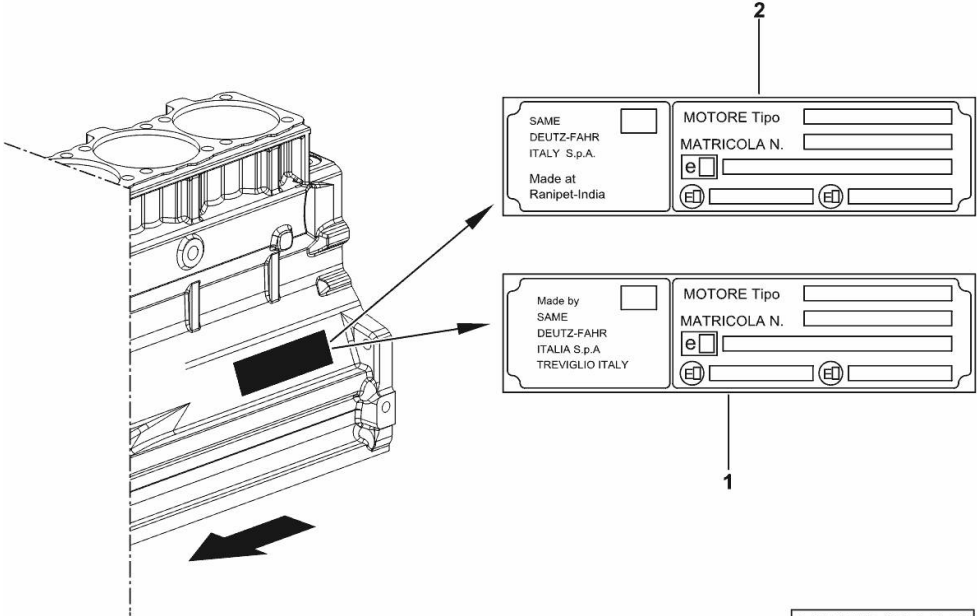

9_STA000_00_0-A-001

CRANKCASE

Fig.	P/n	QTY	Name
------	-----	-----	------

Notes:

FOR ENGINES PRODUCED IN : TREVIGLIO ITALY [DORADO³ 60 -> ZKDR3802W0TS01001]

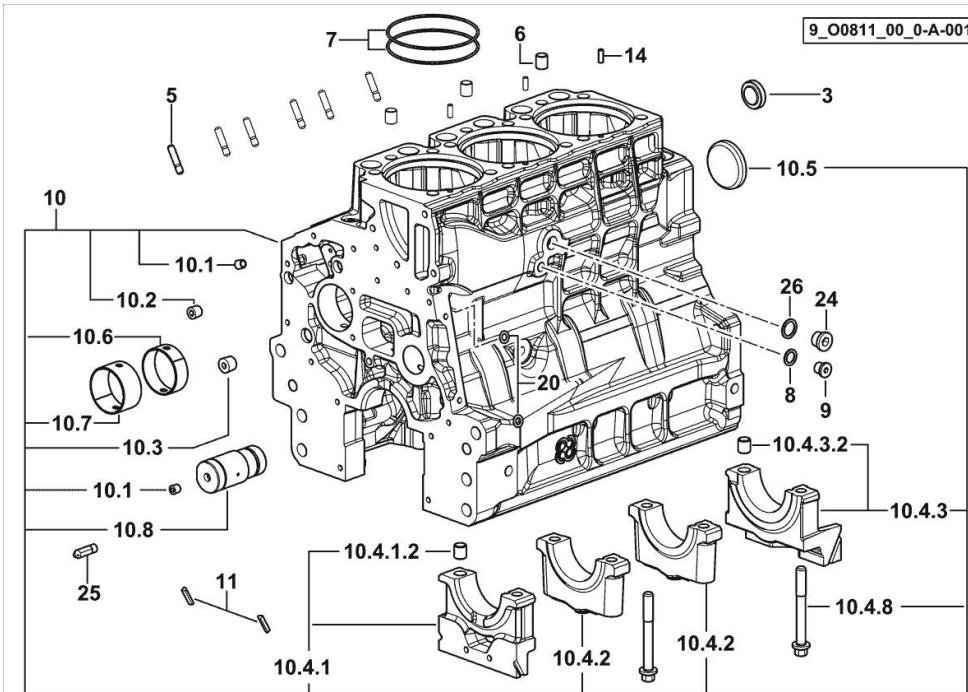

3	2.3199.312.2/20	1	plug m 35x1.5x9.5
5	2.0439.279.7	6	stud bolt m 8 p.1 x 25
6	2.1559.188.2	3	bush 11.4 x 14 x16
7	2.1539.259.0	6	special oil seal 107.62x2.62
8	2.1560.010.0	1	gasket 14.2 x 20
9	2.3199.292.0	1	plug 1/4" gas
10	0.014.9911.4/30	1	crankcase
10.1	2.3130.001.1	12	plug 1/8" gas
10.2	2.3130.002.1	4	plug 1/4" gas
10.3	2.3130.003.1	2	plug 3/8" gas
10.4.1	0.065.1112.3	1	support
10.4.1.2	2.1699.165.0	1	bush 12.3x15x16
10.4.2	0.065.1114.0/10	2	support
10.4.3	0.065.1116.3	1	support
10.4.3.2	2.1699.165.0	1	bush 12.3x15x16
10.4.8	0.065.1117.0	8	screw m 12 x 100
10.5	2.3179.012.0	1	plug 60
10.6	0.065.1140.0	3	special bushing 59X55X20
10.7	0.065.1141.0	1	special bushing 59X55X30
10.8	0.014.1340.0/10	1	pin mm 85
11	0.066.1152.0/10	4	gasket
14	2.1549.154.2	3	bush 4.8x5.8x16
20	2.1470.004.2	4	lock washer 8
24	2.3120.101.0	1	plug m 18 p.1.5
25	0.013.4946.0/10	1	sprayer nozzle
26	2.1560.014.0	1	washer 18.2 x 24

MONOBLOC ENGINE-GEARBOX CONNECTING FLANGE

Fig.	P/n	QTY	Name
------	-----	-----	------

Notes:FOR ENGINES PRODUCED IN : TREVIGLIO ITALY [DORADO³ 60 -> ZKDR3802W0TS01001]

1	0.007.7752.0/30	1	flange
2	2.0112.511.2	8	screw m 14 p.2 x 30
3	2.1651.912.0	2	cylindrical plug 12x28
4	2.1651.917.0	1	cylindrical plug 12x40
5	2.0432.257.7	1	stud bolt m 12 p.1.75 - 1.25 x 30
6	2.0439.250.7	1	stud bolt m 12 / m 10 x 30
7	0.011.9294.0/10	1	bush

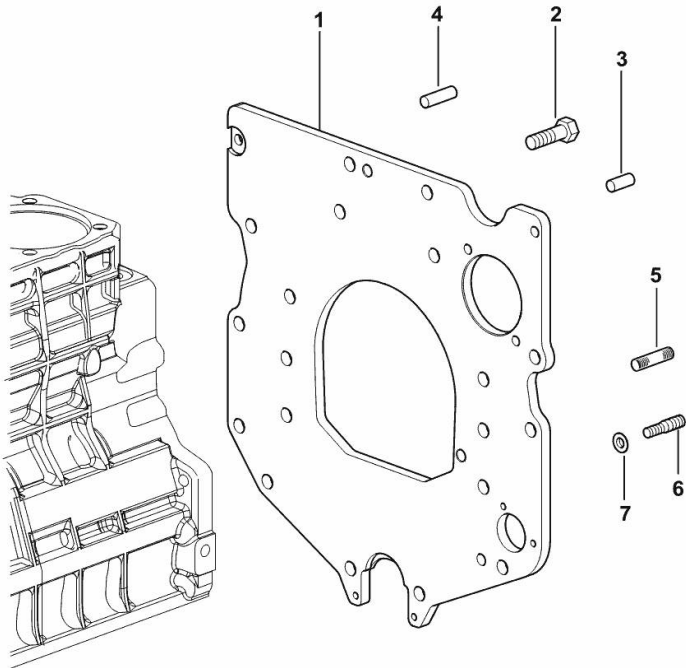

9_37311_01_0-A-001

ENGINE CRANKSHAFT PULLEY WITH RING-FEEDER RINGS

Fig.	P/n	QTY	Name
------	-----	-----	------

Notes:FOR ENGINES PRODUCED IN : TREVIGLIO ITALY [DORADO³ 60 -> ZKDR3802W0TS01001]

1	0.015.6055.0	1	pulley
2	0.011.3515.0/20	1	hub Z = 48
3	0.065.1256.0	2	ring 45x52
4	2.1579.865.0	1	spacer 45.2x51.8x10
5	2.0439.195.7	1	stud bolt m 20 p.1.5x80
6	2.1019.094.7	1	nut m 20 p.1.5
7	2.0112.320.2	6	screw m 10 p.1.5 x 55
8	2.1470.006.2	6	lock washer 10

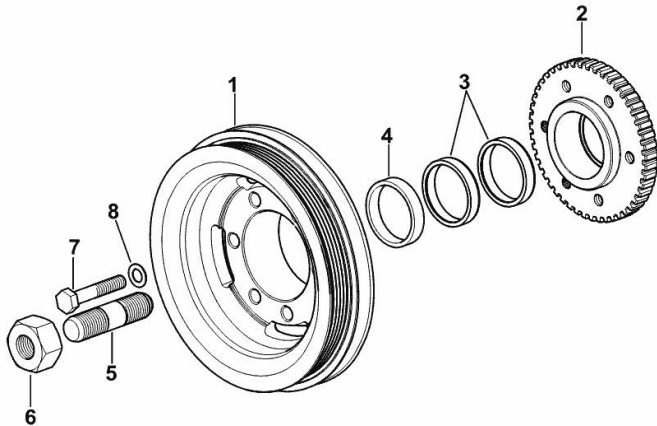

9_O6312_03_0-A-001

COOLANT PUMP AND ALTERNATOR DRIVEBELT

Fig.	P/n	QTY	Name
------	-----	-----	------

Notes:
- FOR MODELS WITH COMPRESSOR [DORADO³ 60 -> ZKDR3802W0TS01001] 1002 <-

1	2.4119.143.0	1	belt AV 12.7x1225 mm
2	2.4119.214.0	1	belt PV-K5 (mm 17.4x1245)

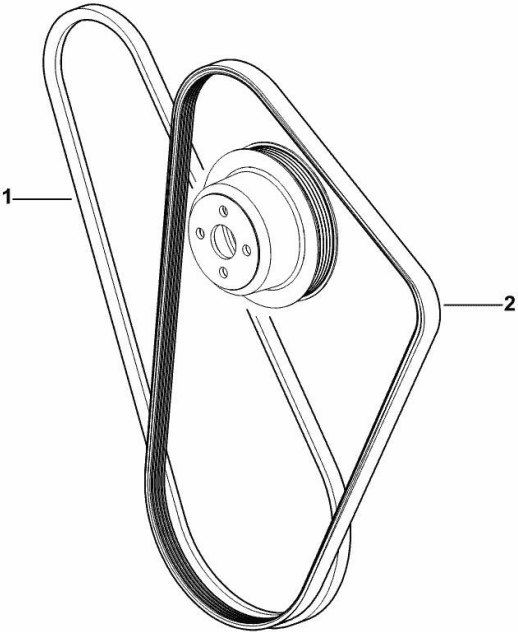

9_O6317_09_0-A-001

COOLANT PUMP AND ALTERNATOR DRIVEBELT

Fig.	P/n	QTY	Name
------	-----	-----	------

Notes:
- FOR MODELS WITH COMPRESSOR [DORADO³ 60 -> ZKDR3802W0TS01001] -> 1007

1	2.4119.143.0	1	belt AV 12.7x1225 mm
2	2.4119.206.0	1	belt PV-K5 17.4x1270 mm

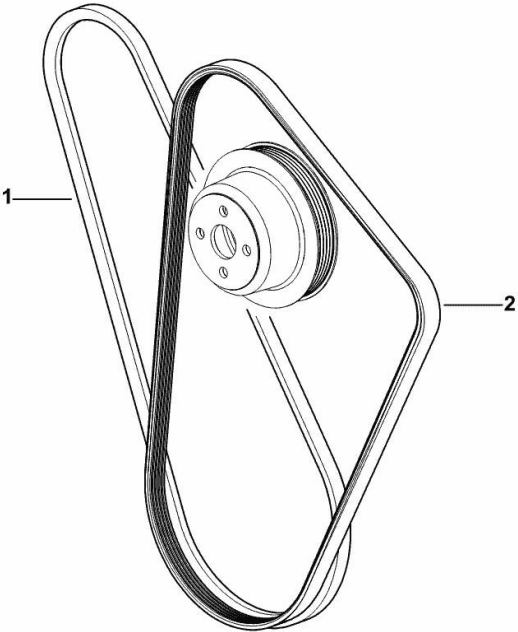

9_O6617_09_0-A-001

COOLANT PUMP AND ALTERNATOR DRIVEBELT

Fig.	P/n	QTY	Name
------	-----	-----	------

Notes:
[DORADO³ 60 -> ZKDR3802W0TS01001] 1005 <-

1	2.4119.187.0	1	belt PV-K5 (mm 1230)
---	--------------	---	----------------------

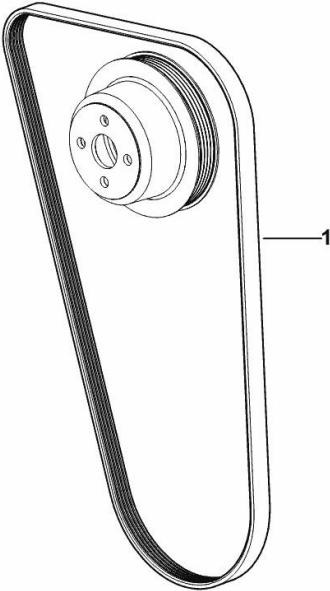

9_O6817_09_0-A-001

COOLANT PUMP AND ALTERNATOR DRIVEBELT

Fig.	P/n	QTY	Name
------	-----	-----	------

Notes:
[DORADO³ 60 -> ZKDR3802W0TS01001] -> 1009

1	2.4119.188.0	1	belt PV-K5 17.4x1275 mm
---	--------------	---	-------------------------

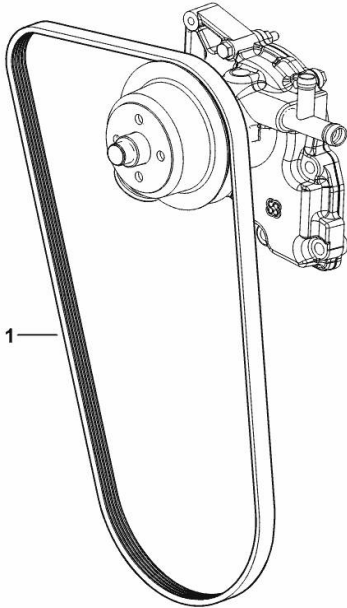

9_N1817_09_0-A-001

CRANKSHAFT

Fig.	P/n	QTY	Name
------	-----	-----	------

Notes:
 FOR ENGINES PRODUCED IN : TREVIGLIO ITALY [DORADO³ 60 -> ZKDR3802W0TS01001]

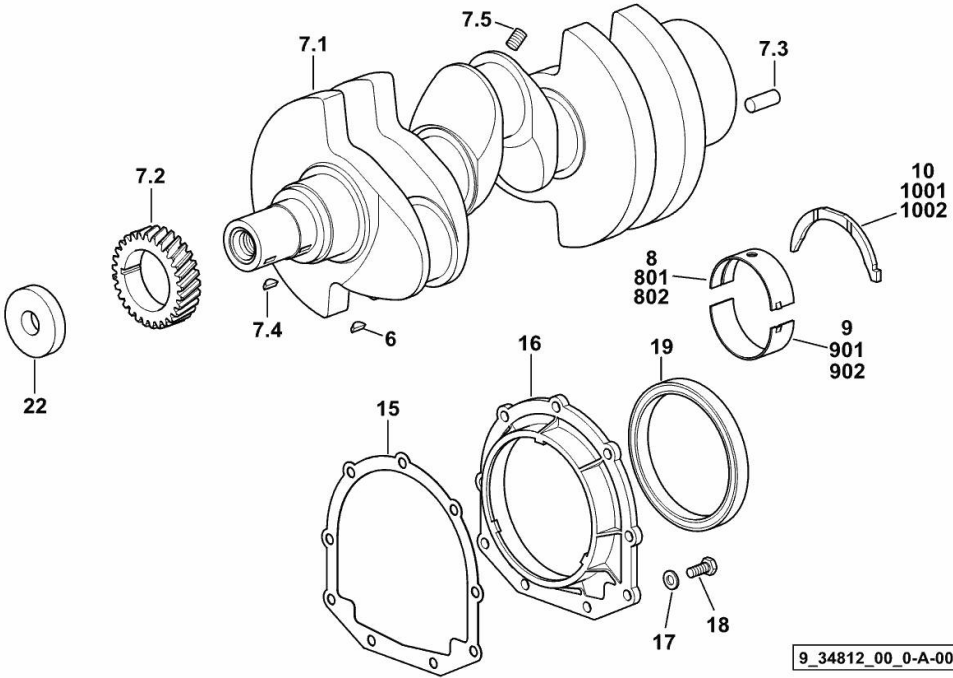

6	2.1720.006.0	1	key 4x6.5
7.1	0.007.1554.0/20	1	crankshaft
7.2	0.065.1323.0/30	1	gear Z = 29
7.3	2.1651.915.0	1	pin 12x35
7.4	2.1720.006.0	1	key 4x6.5
7.5	2.3130.001.1	3	plug 1/8" gas
8	0.065.1215.0/10	4	main half bushing STANDARD
9	0.065.1216.0/10	4	main half bushing STANDARD
10	0.065.1218.0	4	shim STANDARD
15	0.065.1254.0/20	1	gasket
16	0.007.1711.0/10	1	cover
17	2.1475.002.2	9	conical washer 8
18	2.0112.207.2	9	screw m 8 p 1.25 x 20
19	2.1529.073.0	1	special oil seal 110x130x13
22	2.1599.524.7	1	washer 21x60x12
801	0.065.1215.7		main half bushing - mm 0.25
802	0.065.1215.8		main half bushing - mm 0.50
901	0.065.1216.7		main half bushing - mm 0.25
902	0.065.1216.8		main half bushing - mm 0.50
1001	0.065.1218.7		shim + mm 0.10
1002	0.065.1218.8		shim + mm 0.15

9_34812_00_0-A-001

ENGINE FLYWHEEL

Fig.	P/n	QTY	Name
------	-----	-----	------

Notes:
[DORADO³ 60 -> ZKDR3802W0TS01001]

1	0.014.2774.3	1	flywheel
1.2	0.069.1242.0	1	crown wheel Z = 121
2	2.0139.036.2	6	screw m 12 p.1.25 x 35

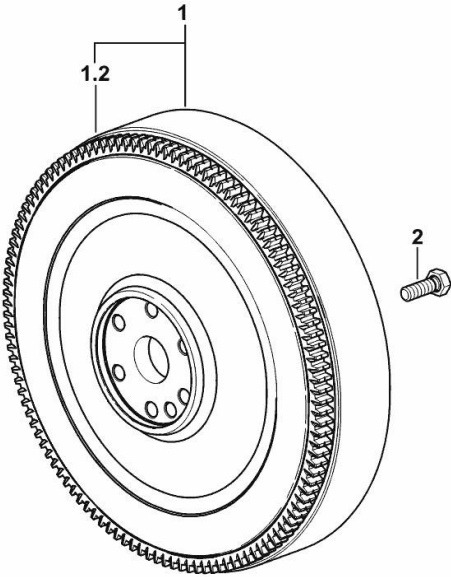

9_N1112_02_0-A-001

CYLINDER - PISTON - CONNECTING ROD

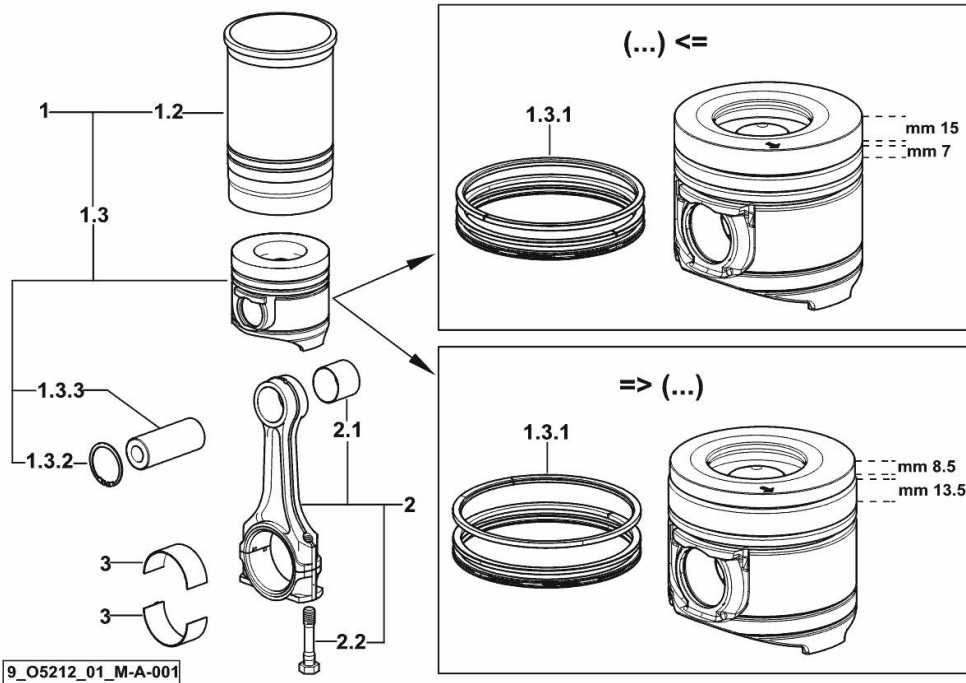

Fig.	P/n	QTY	Name
------	-----	-----	------

Notes:

FOR ENGINES PRODUCED IN : TREVIGLIO ITALY [DORADO³ 60 -> ZKDR3802W0TS01001]

1	0.O68.0065.A	3	cyl. piston assembly "A" (...) <= - CLASS A
1	0.O68.0065.B	3	cyl. piston assembly "B" (...) <= - CLASS B
1	0.Q92.0065.A	3	cyl. piston assembly "A" => (...) - CLASS A
1	0.Q92.0065.B	3	cyl. piston assembly "B" => (...) - CLASS B
1.2	0.A12.2675.0	1	engine cylinder "A" - CLASS A
1.2	0.B12.2675.0	1	engine cylinder "B" - CLASS B
1.3	0.O68.0060.A	1	complete piston "A" (...) <= - CLASS A
1.3	0.O68.0060.B	1	complete piston "B" (...) <= - CLASS B
1.3	0.Q92.0060.A	1	complete piston "A" => (...) - CLASS A
1.3	0.Q92.0060.B	1	complete piston "B" => (...) - CLASS B
1.3.1	0.081.0090.6/10	1	piston ring set (...) <=
1.3.1	0.Q92.0052.6	1	piston ring set => (...)
1.3.2	2.1411.014.1	2	circlip 35
1.3.3	0.078.1236.0	1	piston pin Ø 18 / Ø 35 / L = mm 86
2	0.014.5175.3	3	engine connecting rod
2.1	2.1559.255.0	1	special bushing 34.60x39.130x34.65
2.2	2.0399.213.0	2	screw m 12 p.1.25x61.5
3	0.065.1225.0	6	con.rod half bushing STANDARD - A = 28.75 -> 29.00
3	0.065.1225.7	6	con.rod half bushing - mm 0.25
3	0.065.1225.8	6	con.rod half bushing - mm 0.50

TIMING CASE

Fig.	P/n	QTY	Name
------	-----	-----	------

Notes:
 FOR ENGINES PRODUCED IN : TREVIGLIO ITALY [DORADO³ 60 -> ZKDR3802W0TS01001]

15	2.0432.003.7	2	stud bolt m 8 p.1.25 / p.1 x 20
16	2.0312.214.2	7	screw m 8 p.1.25 x 40
17	2.1480.014.1	15	washer 8
18	0.013.4981.0	1	guard
19	0.065.1150.0/30	1	gasket
20	2.1470.004.2	4	lock washer 8
21	2.1011.405.2	2	nut m 8 p.1
22	2.0312.208.2	8	screw m 8 p.1.25 x 25
23	2.1529.167.0	1	oil seal

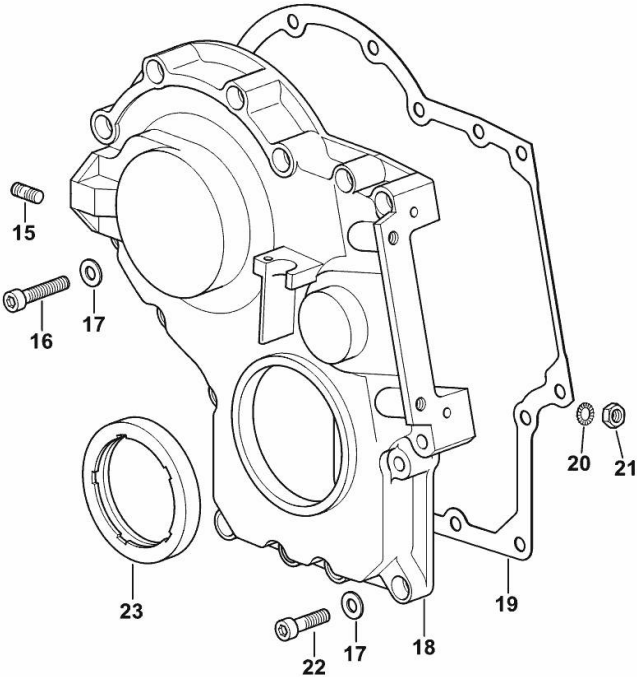

9_O0811_00_0-B-001

TIMING COVER FIXING

Fig.	P/n	QTY	Name
------	-----	-----	------

Notes:
FOR ENGINES PRODUCED IN : TREVIGLIO ITALY [DORADO³ 60 -> ZKDR3802W0TS01001]

4	0.016.7791.0	2	small column
---	--------------	---	--------------

9_O6311_01_0-B-001

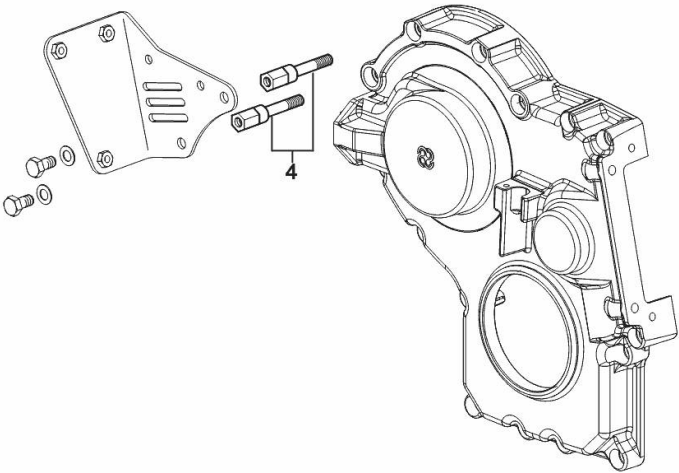

CASING COVER

Fig.	P/n	QTY	Name
------	-----	-----	------

Notes:
FOR ENGINES PRODUCED IN : TREVIGLIO ITALY [DORADO³ 60 -> ZKDR3802W0TS01001]

30	0.065.1152.0	1	gasket
31	0.013.6374.2	1	cover
32	0.013.6368.0/20	4	stud bolt m 8 p.1 / = mm 51.5
34	2.1310.004.2	8	flat washer 8.4x17
35	2.1011.405.2	4	nut m 8 p.1

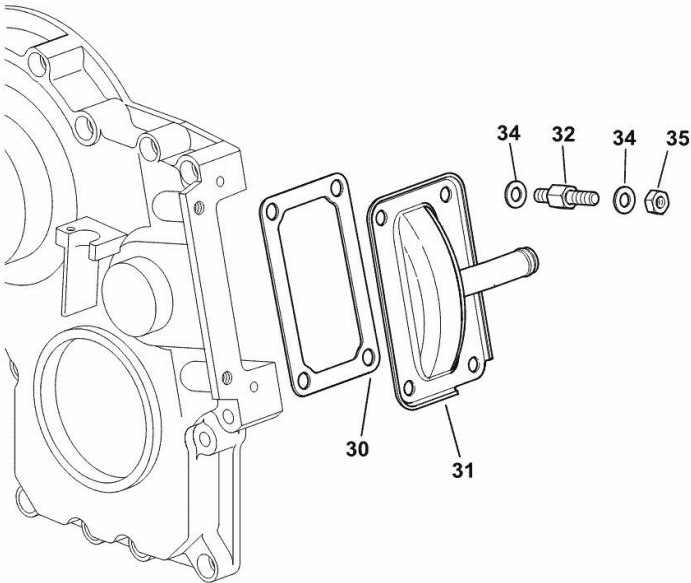

9_N1411_01_0-A-001

CAMSHAFT

Fig.	P/n	QTY	Name
------	-----	-----	------

Notes:
 FOR ENGINES PRODUCED IN : TREVIGLIO ITALY [DORADO³ 60 -> ZKDR3802W0TS01001]

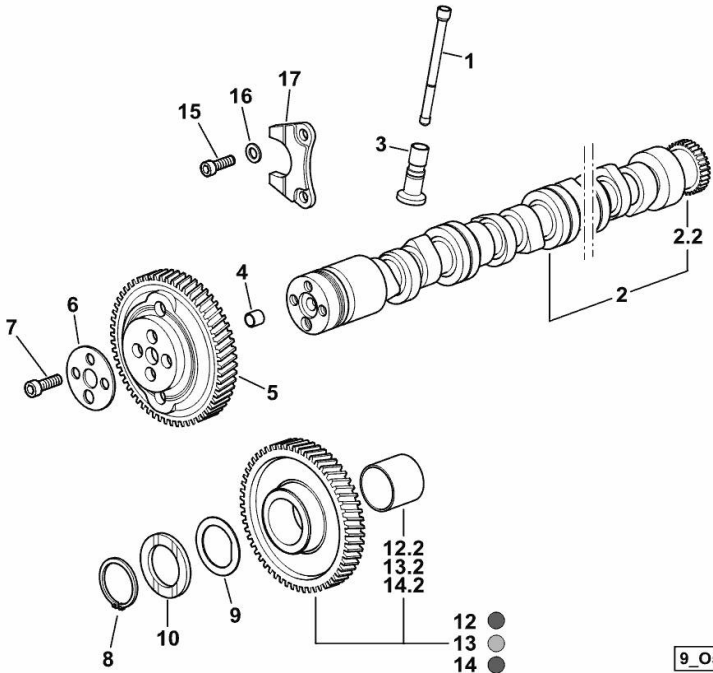

1	0.065.1331.2	6	rod
2	0.016.3967.3	1	camshaft
2.2	0.065.1324.0/10	1	gear Z = 32
3	0.065.1330.0	6	tappets
4	2.1559.398.0	1	bushing 10.5x13x12
5	0.013.5017.0	1	gear z=58
6	0.065.1350.0	1	small disc
7	2.0132.207.2	4	screw m 10 p.1 x 25
8	2.1410.016.1	1	circlip 40
9	0.065.1352.0	1	shim
10	0.018.2233.0	2	shoulder ring
12	0.007.1177.3/20	1	gear z = 57 - WITH RED IDENTIFICATION STAMP
12.2	2.1559.185.0/10	1	bushing
13	0.007.1178.3/20	1	gear z = 57 - WITH YELLOW IDENTIFICATION STAMP
13.2	2.1559.185.0/10	1	bushing
14	0.007.1179.3/20	1	gear z = 57 - WITH GREEN IDENTIFICATION STAMP
14.2	2.1559.185.0/10	1	bushing
15	2.0312.205.2	2	screw
16	2.1480.014.1	2	washer 8
17	0.065.1353.0	1	small plate

9_O5213_00_0-A-001

Thank you so much for reading.
Please click the “Buy Now!”
button below to download the
complete manual.



After you pay.

You can download the most
perfect and complete manual in
the world immediately.

Our support email:

ebooklibonline@outlook.com