

Section: ENGINE  
**CRANKCASE**

Fig.	P/n	QTY	Name
------	-----	-----	------

Notes:  
 [EXPLORER 70 Special -> 15500]

1	0.087.0050.6/10		gasket set - FOR ENGINE MOUNTING
2	2.0112.511.2	8	screw m 14 p.2 x 30
3	0.066.1130.0/20	1	flange
8	2.1099.108.2	4	special nut m 10 p.1
9	2.1560.006.0	8	gasket 10.2 x 16
10	0.086.1550.2	4	sprayer nozzle
11	0.065.1160.3/20	4	valve
12	2.1539.047.0	1	special oil seal 26.7x1.78
13	2.3199.405.2	1	plug m 28 p.1.5
16	2.0432.003.7	12	stud bolt m 8 p.1.25 / p.1 x 20
19	2.1539.130.0/10	4	special oil seal 117.07x3.53
20	0.007.0762.0/50	4	engine cylinder
25	0.066.1152.0/10	4	gasket
26	0.007.1140.6/10	1	crankcase
27	0.065.1112.7	1	support
28	2.1699.165.0	1	bush 12.3x15x16
29	0.065.1116.3	1	support
30	2.1699.165.0	1	bush 12.3x15x16
31	0.066.1151.0	1	pin
32	0.065.1141.0	1	special bushing 59X55X30
33	0.065.1140.0	4	special bushing 59X55X20
34	2.3179.012.0	1	plug 60
35	2.3130.001.1	11	plug 1/8" gas
36	2.3130.002.1	2	plug 1/4" gas
37	2.3130.003.1	7	plug 3/8" gas
38	2.3199.092.0	4	plug 8 x 12
41	2.1324.011.0	1	plug
42	0.065.1117.0	10	screw m 12 x 100
43	0.065.1114.0/10	3	support
44	2.1651.912.0	2	cylindrical plug 12x28
45	2.1651.917.0	1	cylindrical plug 12x40
46	2.0432.255.7	2	stud bolt m 12 p.1.75-1.25x25
52	2.1560.017.0	1	gasket 22.2 x 27
53	2.3120.002.4	1	plug m 22 x 1.5

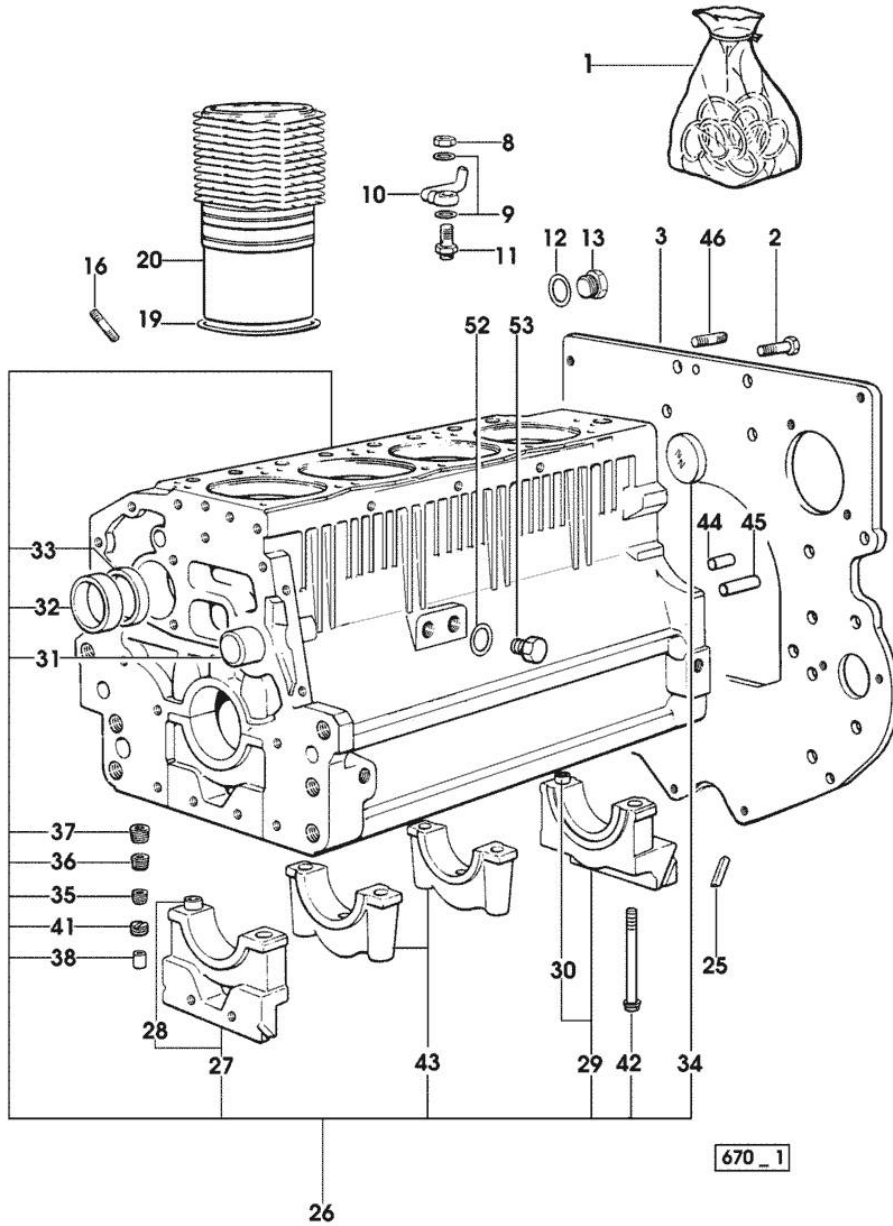

Section: ENGINE

**TIMING CASE**

Fig.	P/n	QTY	Name
------	-----	-----	------

**Notes:**

[EXPLORER 70 Special -&gt; 15500]

1	0.007.1262.3/50	1	guard
2	0.007.1271.0/10	1	small column m 8 p.1.25 / L = mm 60
3	0.007.1272.0/10	2	small column m 8 p.1.25 / L = mm 50
5	2.1310.004.2	3	flat washer 8.4x17
7	2.0112.205.2	3	screw m 8 p.1.25 x 16

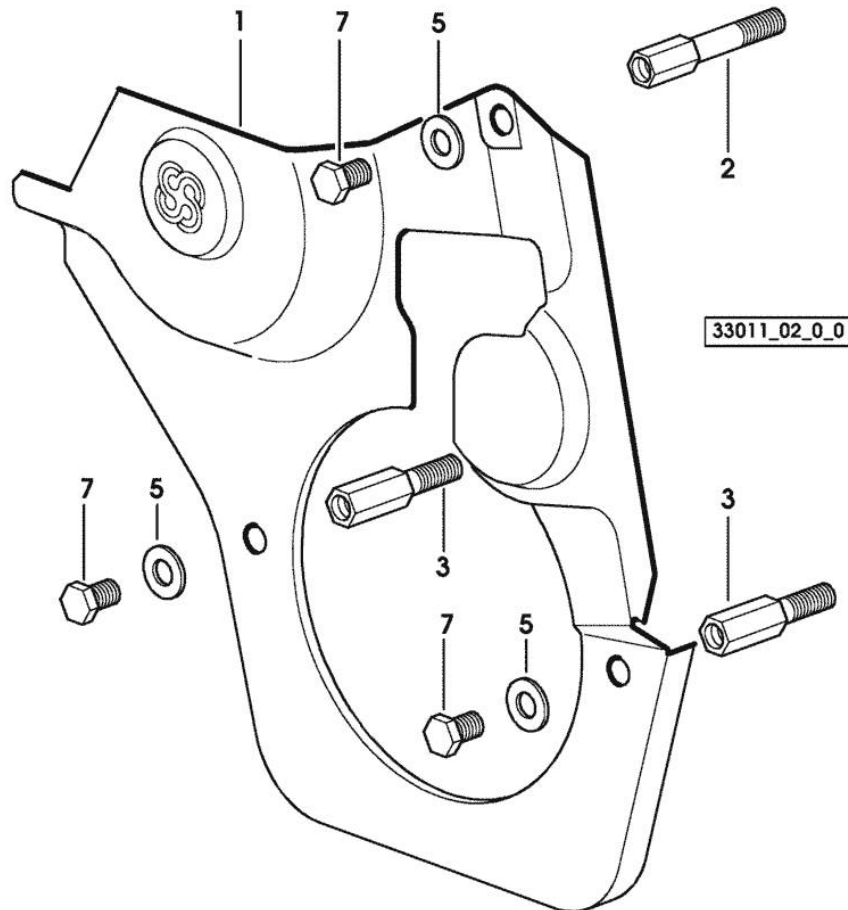

Section: ENGINE  
TIMING CASE

Fig.	P/n	QTY	Name
------	-----	-----	------

Notes:

[EXPLORER 70 Special -> 15500]

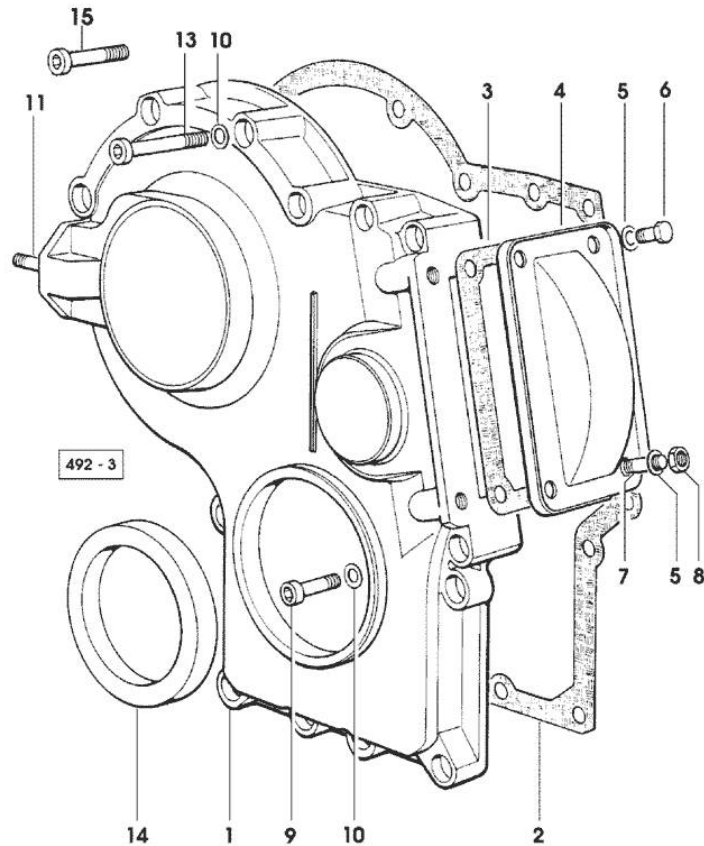

1	0.065.1132.0/60	1	guard
2	0.065.1150.0/30	1	gasket
3	0.065.1152.0	1	gasket
4	0.065.1151.0	1	cover
5	2.1470.004.2	4	lock washer 8
6	2.0112.205.2	2	screw m 8 p.1.25 x 16
7	2.0432.003.7	2	stud bolt m 8 p.1.25 / p.1 x 20
8	2.1011.405.2	2	nut m 8 p.1
9	2.0312.208.2	8	screw m 8 p.1.25 x 25
10	2.1480.014.1	15	washer 8
11	2.0432.003.7	2	stud bolt m 8 p.1.25 / p.1 x 20
13	2.0312.219.2	4	screw m 8 p.1.25x65
14	2.1529.141.0	1	special oil seal
15	2.0312.214.2	3	screw m 8 p.1.25 x 40

**CRANKSHAFT**

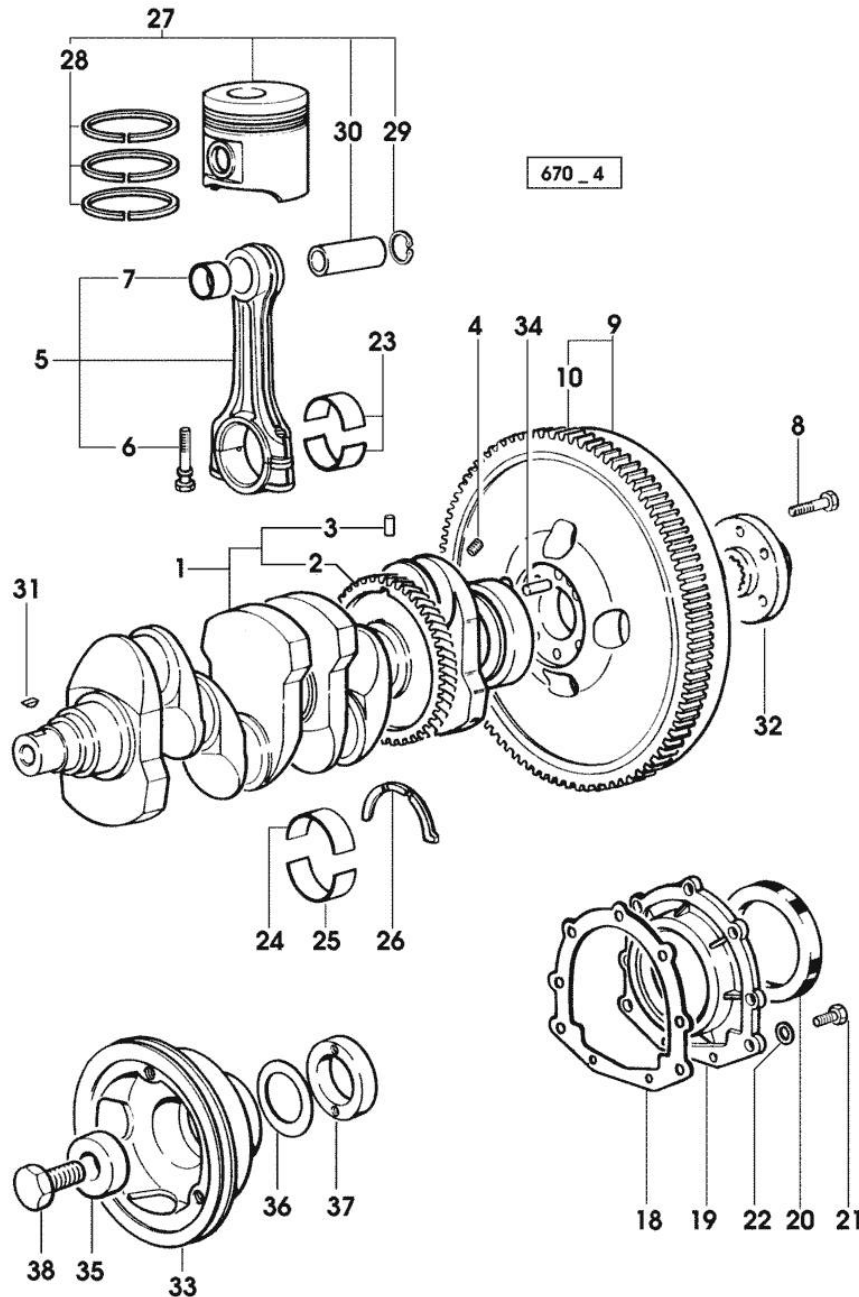

Fig.	P/n	QTY	Name
------	-----	-----	------

**Notes:**

[EXPLORER 70 Special -> 15500]

1	0.086.1210.3/30	1	crankshaft
2	0.065.1211.0/10	1	crown wheel
3	2.1630.608.0	1	pin 6x16
4	2.3130.001.1	4	plug 1/8" gas
5	0.078.1220.3/30	4	engine connecting rod
6	2.0399.213.0	8	screw m 12 p.1.25x61.5
7	2.1559.114.0/10	4	special bushing
8	2.0139.022.2	6	screw m 12 p.1.25x55
9	0.007.1702.3/30	1	flywheel
			-> 15593 X 80HP
			- FOR 80HP LP WITH 385 mm DIAMETER FLYWHEEL
			-> 2975 X 90HP
			-> 1076 X 90HP LOW PROFILE
9	0.008.4049.3	1	flywheel mm 373
			15592 <- X 80HP
			- FOR 80HP LP WITH 373 mm DIAMETER FLYWHEEL
			2974 <- X 90HP
			1075 <- X 90HP LOW PROFILE
9	0.076.1247.3/20	1	flywheel
			- X 70HP
10	0.065.1242.0	1	crown wheel Z = 123
18	0.065.1254.0/20	1	gasket
19	0.007.1711.0/10	1	cover
20	2.1529.073.0	1	special oil seal 110x130x13
21	2.0112.207.2	9	screw m 8 p 1.25 x 20
22	2.1475.002.2	9	conical washer 8
23	0.065.1225.0	8	con.rod half bushing STANDARD - A = 28.75 -> 29.00
23	0.065.1225.7		con.rod half bushing - mm 0.25
23	0.065.1225.8		con.rod half bushing - mm 0.50
24	0.065.1215.0	5	main half bushing STANDARD
24	0.065.1215.7		main half bushing - mm 0.25
24	0.065.1215.8		main half bushing - mm 0.50
25	0.065.1216.0	5	main half bushing
25	0.065.1216.7		main half bushing - mm 0.25
25	0.065.1216.8		main half bushing - mm 0.50
26	0.065.1218.0	4	shim STANDARD
26	0.065.1218.7		shim + mm 0.10
26	0.065.1218.8		shim + mm 0.15
27	0.086.0060.6/30	4	complete piston
			- X 70HP - 80HP
27	0.338.0060.6/20	4	complete piston



**COUNTERWEIGHTS**

Fig.	P/n	QTY	Name
------	-----	-----	------

**Notes:**

[EXPLORER 70 Special -> 15500]

1	0.086.1233.3/30	1	mass sx/lh/li
2	2.1559.115.0	2	special bushing 26x30x30
3	2.1652.302.0	1	roll pin 4x6
4	0.000.0000.1		cannot be supplied
5	0.065.1233.3/30	1	mass dx/rh/re
6	2.1410.018.1	1	circlip 45
7	2.1652.302.0	1	roll pin 4x6
8	2.1559.115.0	2	special bushing 26x30x30
9	0.000.0000.1		cannot be supplied
10	2.1589.185.0	4	shoulder ring 26.1x34x1
11	2.1631.717.0	2	roll pin 8 x 40
12	0.086.1231.0/10	1	box
13	2.3130.001.1	4	plug 1/8" gas
14	2.0139.028.2	4	screw m 12
15	2.1579.629.0		spacer 12.5x26x0.1
16	2.1589.049.0		shoulder ring 12.5x26x0.3
17	2.1579.626.0	2	spacer 13.2x16x11
18	2.1589.140.0		shoulder ring mm 0.1
19	2.1589.139.0		shoulder ring mm 0.3
20	2.1699.191.0	1	bush 7x10x16
21	0.065.1234.0/10	2	shaft
22	2.3130.001.1	1	plug 1/8" gas
23	2.1579.628.0		spacer 16.5x26x0.1
23	2.1589.048.0		shoulder ring 16.5x26x0.3

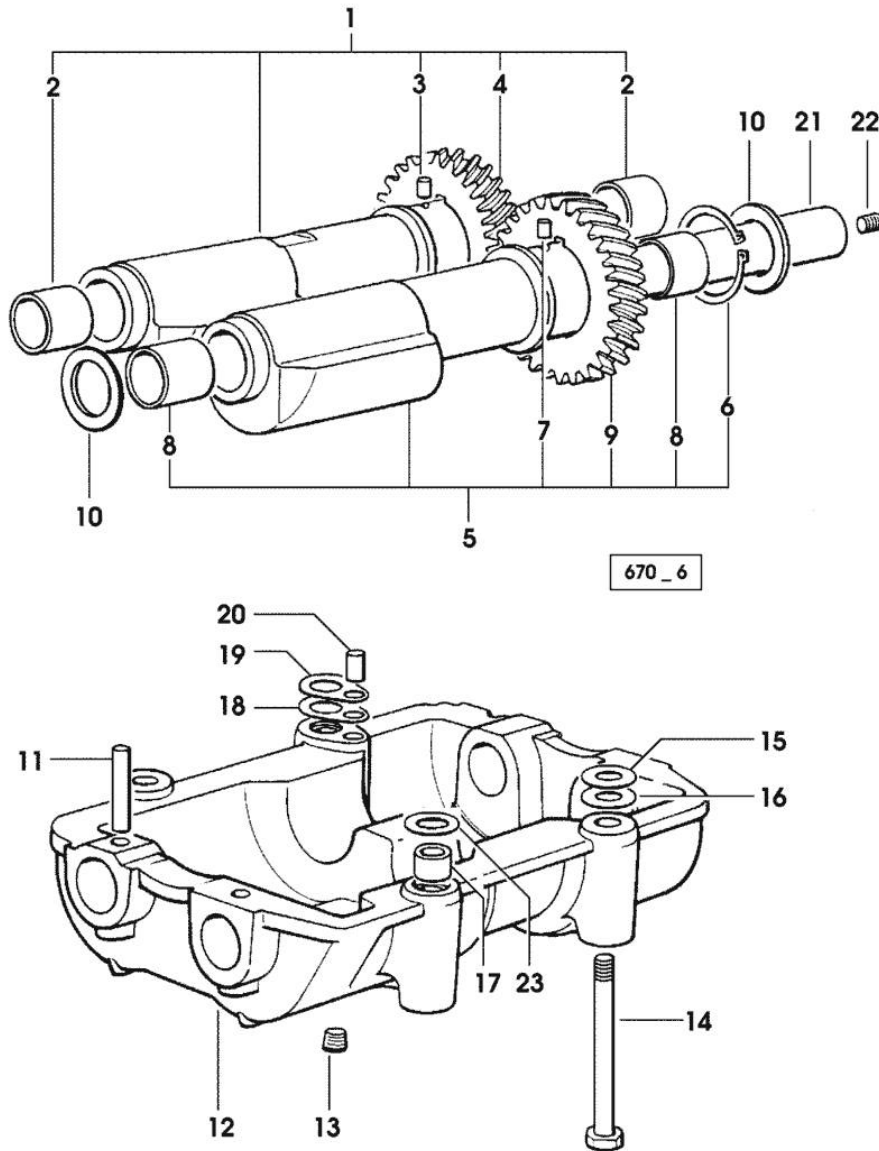

Section: ENGINE

**CAMSHAFT**

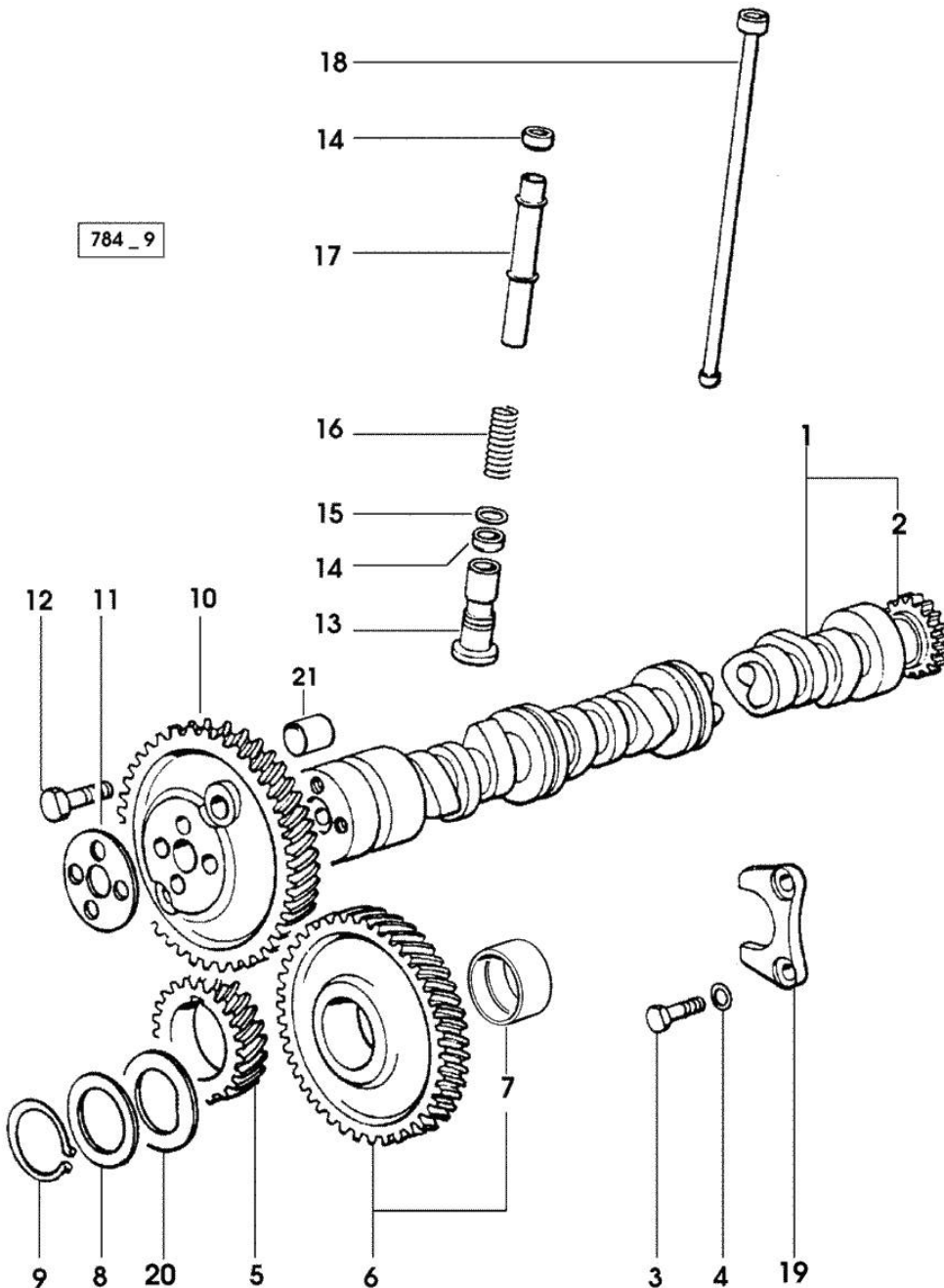

Fig.	P/n	QTY	Name
------	-----	-----	------

Notes:

[EXPLORER 70 Special -> 15500]

1	0.007.1712.3/10	1	camshaft - EXPORT U.S.A.
1	0.066.1310.3/40	1	camshaft
2	0.065.1324.0/10	1	gear Z = 32
3	2.0312.206.2	2	screw m 8 p 1.25 x 20
4	2.1480.014.1	2	washer 8
5	0.065.1323.0/30	1	gear Z = 29
6	0.007.1177.3/10		gear z = 57 - WITH RED IDENTIFICATION STAMP
6	0.007.1178.3/10		gear z = 57 - WITH YELLOW IDENTIFICATION STAMP
6	0.007.1179.3/10		gear z = 57 - WITH GREEN IDENTIFICATION STAMP
7	2.1559.185.0/10	1	bushing
8	0.065.1352.0	1	shim
9	2.1410.016.1	1	circlip 40
10	0.065.1354.0/20	1	gear z=58
11	0.065.1350.0	1	small disc
12	2.0132.207.2	4	screw m 10 p.1 x 25
13	0.065.1330.0	8	tappets
14	2.1569.114.0/10	16	gasket 14x18.5x8
15	2.1599.437.0	8	shoulder ring
16	2.4019.300.1/10	8	spring 18.5x52x2
17	0.065.1332.0	8	sleeve
18	0.065.1331.2	8	rod
19	0.065.1353.0	1	small plate
20	0.065.1351.0	2	shoulder ring
21	2.1559.398.0	1	bushing 10.5x13x12

Section: ENGINE  
CYLINDER HEAD

Fig.	P/n	QTY	Name
------	-----	-----	------

Notes:  
[EXPLORER 70 Special -> 15500]

1	2.0399.130.2/10	4	screw m 8x36x44
2	2.1569.170.0/10	4	gasket 8.2 x 14
3	0.007.1139.0/10	4	small cap
4	0.065.1450.0/30	1	tappet gasket
5	2.1011.421.2	8	nut m 10 p.1.25
6	2.0432.163.7	8	stud bolt m 10 p.1.5 / p.1.25 x 45
7	0.066.1430.0/10	4	support
8	0.066.1432.3	8	rocker arm
9	2.1559.021.0/40	8	bushing 15x19x22
10	2.1410.055.1	8	circlip 19
11	2.1011.405.2	8	nut m 8 p.1
12	0.021.1434.0	8	screw
13	0.074.1423.0	16	conical valve cotter
14	0.066.1425.0	8	cup
15	2.4019.287.0	8	spring
17	2.0432.161.7	4	stud bolt m 10 p.1.5 / p.1.25 x 40
18	0.065.1443.0/20	16	screw
21	0.085.1450.0		head gasket mm 0.5 -A-
21	0.085.1451.0		head gasket mm 0.7 -B-
21	0.085.1452.0		head gasket mm 1.0 -C-
21	0.085.1453.0		head gasket mm 0.8 -D-
22	0.010.6022.0	4	exhaust valve mm 39.1 / Ø mm 9 - X 90HP -> (...) = B
22	0.066.1421.0	4	exhaust valve - X 70HP - 80HP - X 90HP (...) <= A
23	0.010.6016.0	4	inlet valve mm 43.63 / Ø mm 9 - X 70HP - 80HP
23	0.010.6017.0	4	inlet valve mm 43.63 / Ø mm 9 - X 90HP -> (...) = B
23	0.081.1420.0	4	inlet valve Ø mm 9 - X 90HP (...) <= A
24	0.007.1110.3/50	4	engine head - X 70HP - 80HP - X 90HP (...) <= A
24	0.007.1359.3/50	4	engine head - X 90HP -> (...) = B
25	0.066.1427.0	4	valve seat
26	0.078.1426.0	4	valve seat
27	0.007.1779.0/10	8	valve guide
28	0.066.1431.0	4	pin

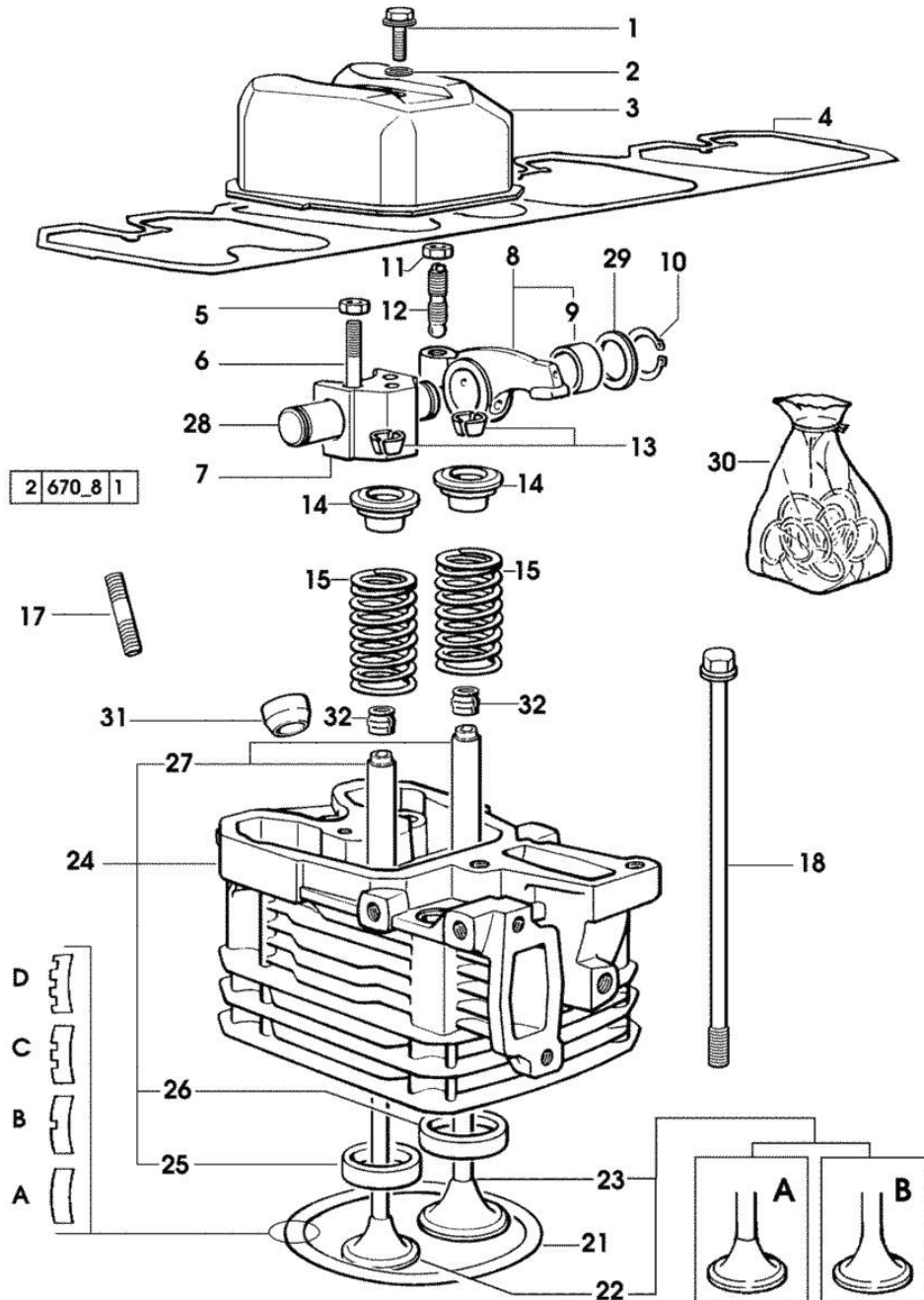



**CYLINDER HEAD**

Fig.	P/n	QTY	Name
29	2.1599.432.0	8	shoulder ring
30	0.085.0057.6/10		gasket set - FOR 1 CYLINDER VALVE GRINDING AND PISTON RINGS REPLACEMENT
31	0.007.1122.0/10	4	bush L = mm 6.4
32	2.1519.117.0	8	special oil seal

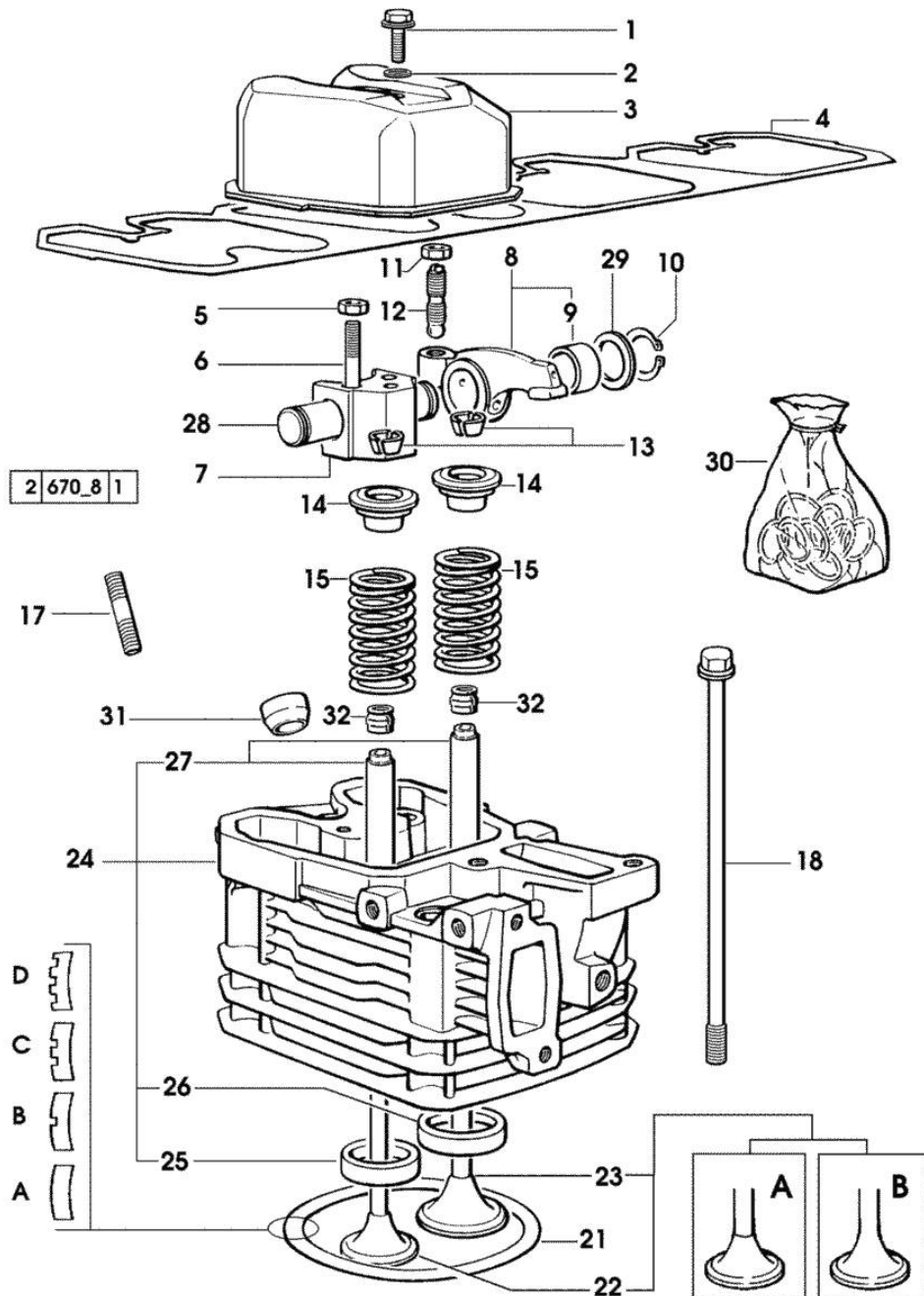

Section: ENGINE

LUBRICATION

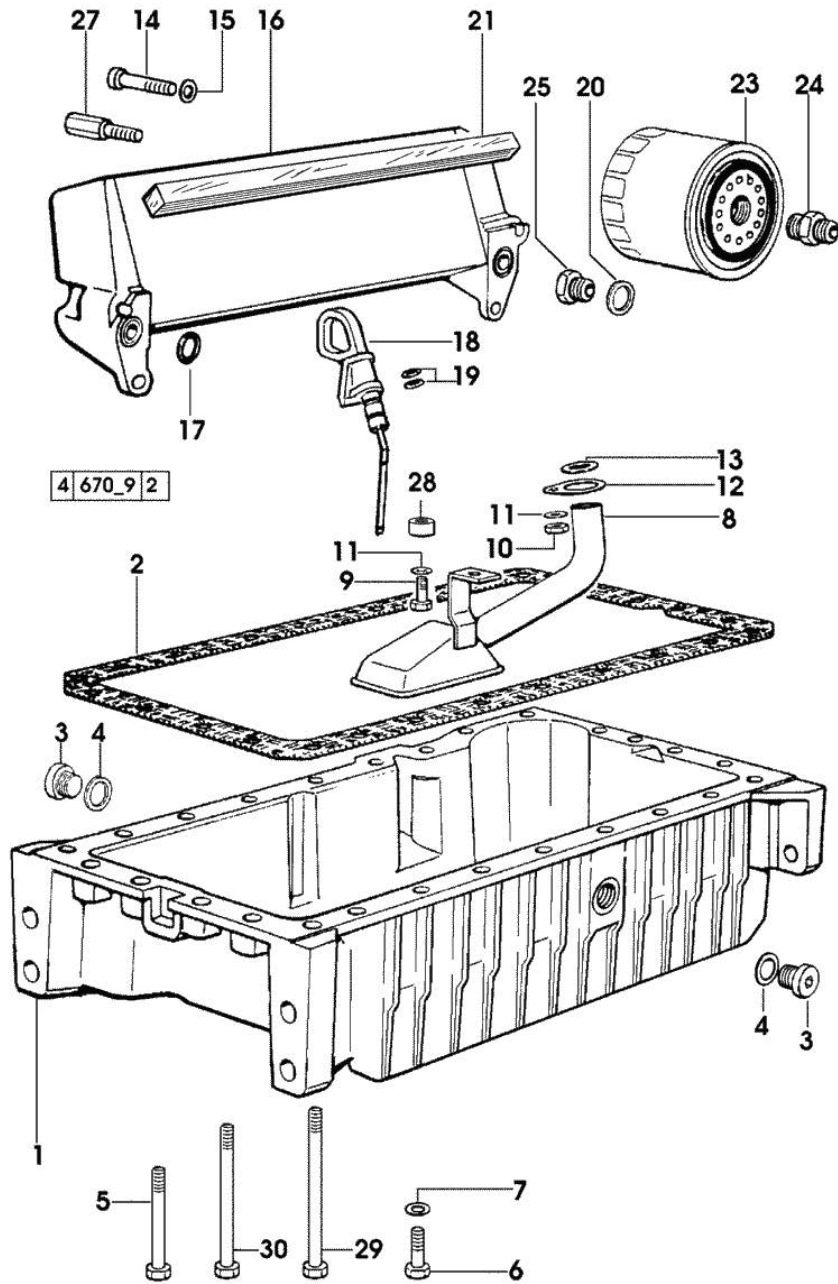
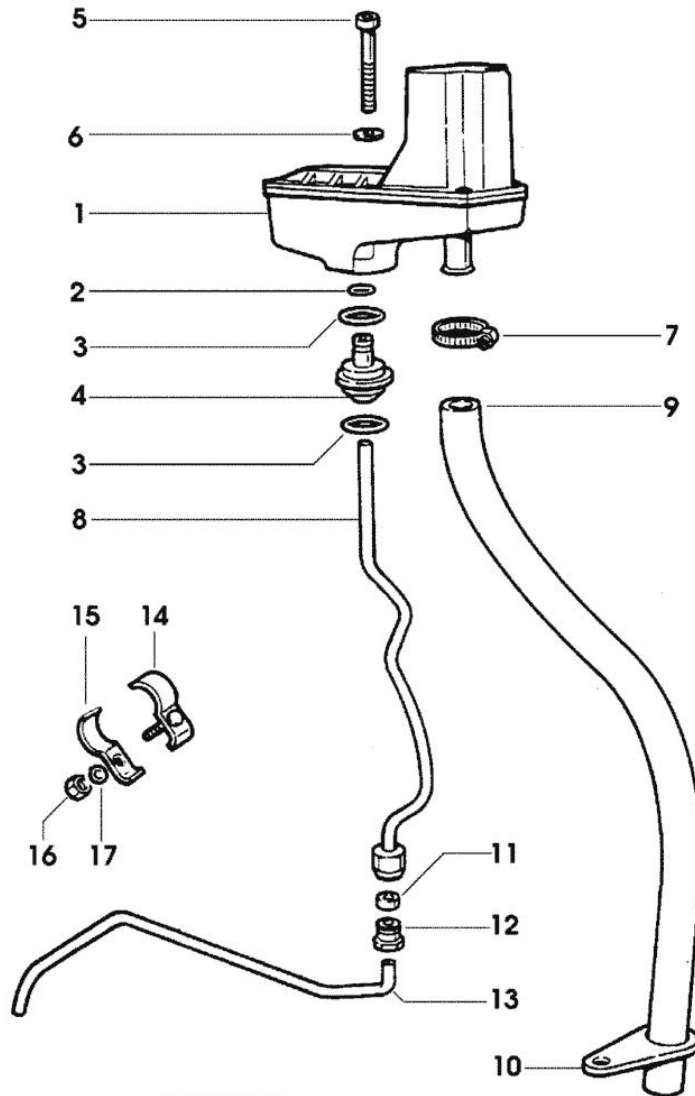

Fig.	P/n	QTY	Name
------	-----	-----	------

Notes:  
[EXPLORER 70 Special -> 15500]

1	0.007.1277.0/40	1	oil sump
2	0.065.1550.0/10	1	gasket
3	2.3199.001.2	2	plug 1/2" gas
4	2.1560.054.0	2	gasket 21 x 26
5	2.0112.226.2	4	screw m 8 p.1.25 x 85
6	2.0112.215.2	17	screw m 8 p.1.25 x 40
7	2.1470.004.2	26	lock washer 8
8	0.065.1531.3/20	1	tube
9	2.0112.209.2	1	screw m 8 p 1.25 x 25
10	2.1011.105.2	1	nut m 8 p.1.25
11	2.1470.004.2	2	lock washer 8
12	0.065.1538.0	1	flange
13	2.1539.040.0	1	special oil seal 21.82 x 3.53
14	2.0312.216.2	2	screw m 8 p.1.25x50
15	2.1310.004.2	2	flat washer 8.4x17
16	0.065.1540.3/20	1	oil cooler
16	0.086.1540.3	1	oil cooler
17	2.1539.048.0	2	special oil seal 20.35x1.78
18	0.086.1513.2/30	1	dipstick
19	2.1539.065.0	2	special oil seal 8.73 x 1.78
20	2.1560.014.0	1	washer 18.2 x 24
21	0.052.1856.0	2	gasket
23	0.044.1567.0	1	oil filter element
23	2.4419.340.0	1	oil filter element
24	2.3339.307.0	1	pipe fitting m 22 p.1.5-3/4"
25	2.3339.353.2/20	1	pipe fitting 12 p.1.5-18 p.1.5
27	2.0399.113.2/10	2	screw
27	2.0399.125.2/10	2	screw m 8 x 55
28	2.1579.766.2	1	spacer 8.5x16x10
29	2.0112.239.2	2	screw m 8 p.1.25 x 150
30	2.0112.235.2	3	screw m 8 p.1.25 x 130

Section: ENGINE  
**LUBRICATION**



642 - 10

Fig.	P/n	QTY	Name
<b>Notes:</b>			
[EXPLORER 70 Special -> 15500]			
1	0.066.1552.4/10	1	sediment bowl ☞ 01.00.30
2	2.1539.074.0	1	special oil seal 7.66 x 1.78
3	2.1539.072.0	2	special oil seal 23.52 x 1.78
4	0.066.1558.0	1	bush
5	2.0312.221.2	2	screw m 8 p.1.25x75
6	2.1480.014.1	2	washer 8
7	2.6859.073.2	1	clamp
8	0.066.1557.2	1	tube
9	0.066.1559.0	1	tube
10	0.075.1151.0	1	bracket
11	2.3350.003.1	1	nosepiece 8
12	2.3339.418.1	1	pipe fitting m 12 p.1
13	0.066.1556.0	1	tube
14	0.075.1552.2	1	bracket
15	0.075.1552.0	1	bracket
16	2.1011.103.2	1	nut m 6 p.1
17	2.1470.002.2	1	lock washer 6

Section: ENGINE  
**LUBRICATION**

Fig.	P/n	QTY	Name
------	-----	-----	------

**Notes:**

- EXPORT U.S.A. [EXPLORER 70 Special -> 15500]

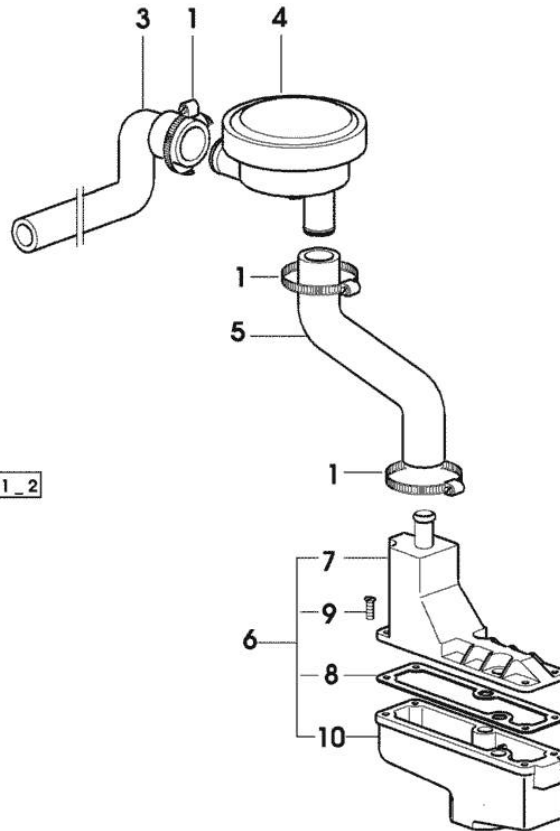

1	2.6850.004.0	4	clamp
3	0.011.0996.0	1	tube - X 70HP - 80HP
3	0.011.3801.0	1	tube - X 90HP
4	0.010.6507.0	1	valve
5	0.011.1026.0	1	tube - X 70HP - 80HP
5	0.011.3800.0	1	tube - X 90HP
6	0.011.1030.4	1	sediment bowl
7	0.011.1028.3	1	cover
8	0.066.1554.0/10	1	gasket
9	2.0351.203.6	4	screw 3.5x9.5
10	0.011.1030.0	1	sediment bowl

**OIL VAPORS SEDIMENT BOWL PARTS**

Fig.	P/n	QTY	Name
------	-----	-----	------

**Notes:**

[EXPLORER 70 Special -> 15500]

1	0.066.1552.0	1	sediment bowl
2	0.066.1555.0	1	tube
3	0.066.1554.0/10	1	gasket
4	0.066.1553.0	1	cover
5	2.0351.203.2	4	screw 3.5x9.5

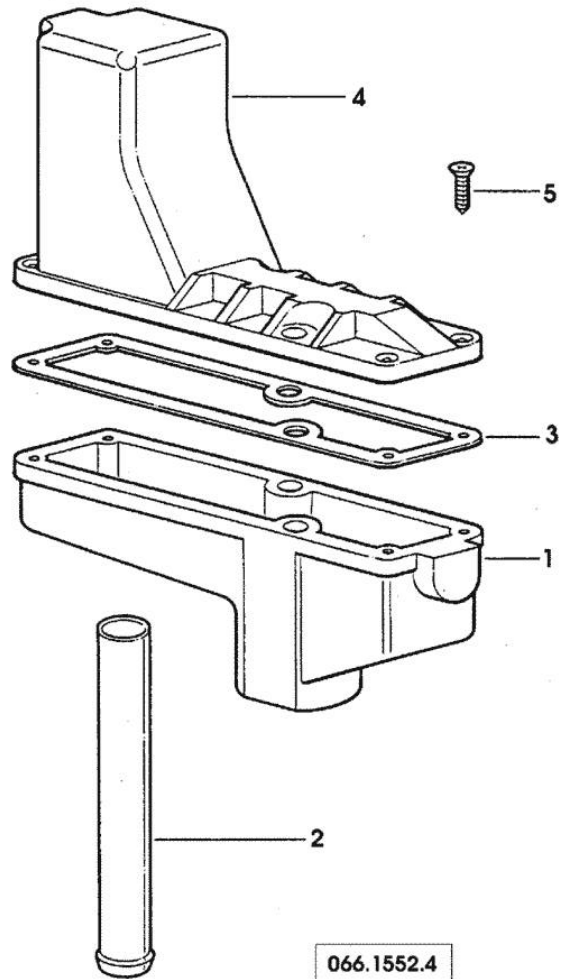

LUBRICATION

Fig.	P/n	QTY	Name
------	-----	-----	------

Notes:

[EXPLORER 70 Special -> 15500]

1	2.0312.206.2	2	screw m 8 p 1.25 x 20
2	2.1480.014.1	2	washer 8
3	0.041.1135.4	1	plug 1" gas
4	2.1569.072.0	1	gasket 32 x 39.5 x 2
5	0.065.1565.0/10	1	pipe union
6	0.010.5441.4/10	1	oil pump
7	0.065.1552.3/60	1	valve
8	2.1539.042.0	1	special oil seal 47.35x1.78
9	2.1651.711.0	2	pin 8 x 14
10	2.0169.005.2	2	screw m 6 p.1 x 12
11	0.065.1569.0/40	1	shaft
12	2.1470.006.2	2	lock washer 10
13	2.0112.324.2	2	screw m 10 p.1.5x75
14	0.065.1560.0/20	2	gasket
15	0.065.1562.0/10	1	joint
16	0.075.1551.4/20	1	support
17	2.2020.001.0	1	ball bearing 15 x 32 x 8.00
18	2.2725.016.0	1	roller cage 15 x 21 x 12
19	2.2680.020.0	1	ring 12 x 15 x 12
20	2.0399.128.2/10	1	screw m 8 p.1 x 8
21	2.2030.002.0	1	ball bearing 12 x 28 x 8
22	2.1219.025.2/10	1	ring nut m 36 p.1.5
23	2.1589.148.0	1	shoulder ring 28.2 x 31.8 x 0.5
23	2.1589.150.0	2	shoulder ring 28.2 x 31.8 x 0.1
23	2.1589.151.0	2	shoulder ring 28.2 x 31.8 x 0.15
24	0.075.1551.3/30	1	support
25	2.1589.146.0	2	shoulder ring 15.2 x 19 x 0.15
25	2.1589.147.0	2	shoulder ring 15.2 x 19 x 0.10
25	2.1589.153.0	1	shoulder ring 15.2 x 19 x 1.00
26	2.1410.057.1	1	circlip 15
27	2.0342.007.2	1	screw m 4 p.0.7x25
28	0.065.1558.6/10	1	bevel drive
29	0.065.1559.0	1	bush
30	2.1560.010.0	1	gasket 14.2 x 20
31	2.3110.403.1	1	plug m 14 p.1.5x12
32	0.065.1581.4/20	1	valve
33	2.1539.048.0	1	special oil seal 20.35x1.78
34	2.1539.072.0	1	special oil seal 23.52 x 1.78
35	2.1480.014.1	2	washer 8
36	2.0312.215.1	2	screw m 8 p.1.25 x 45
37	0.065.1567.0/10	1	filter

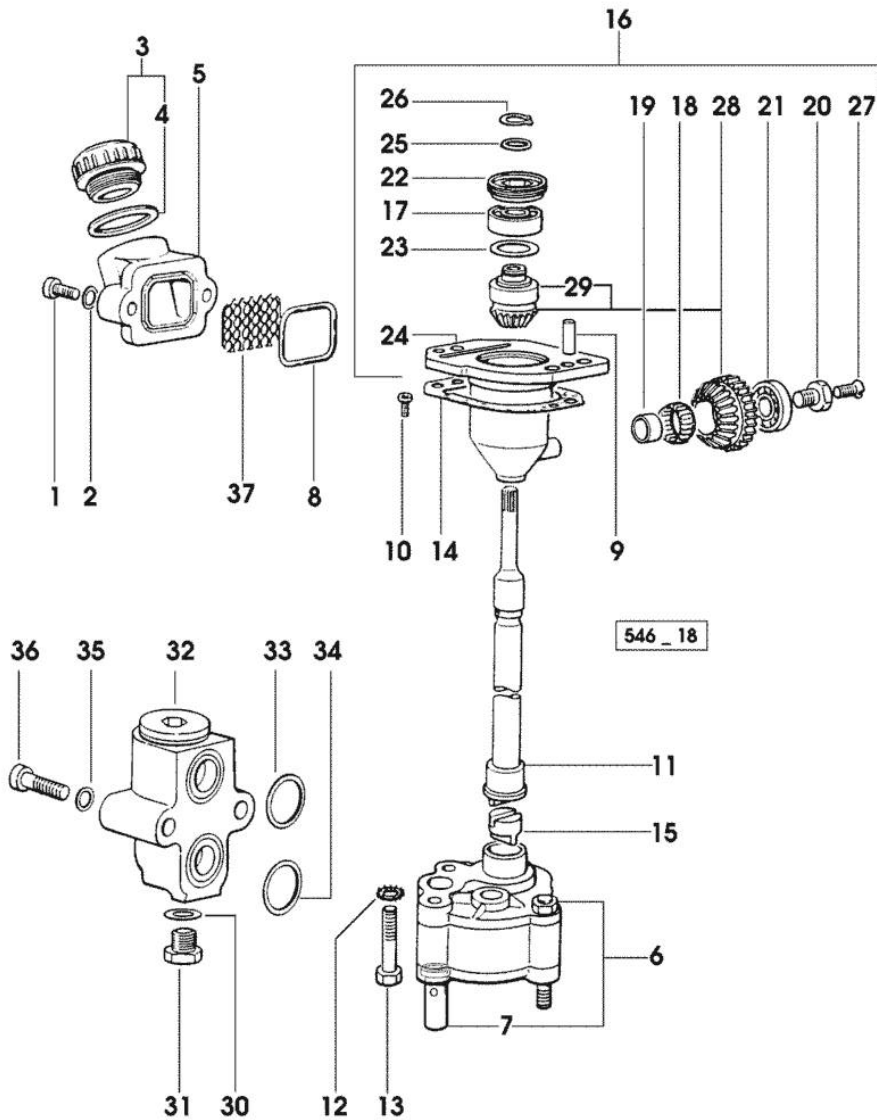

**FUEL SUPPLY SYSTEM**

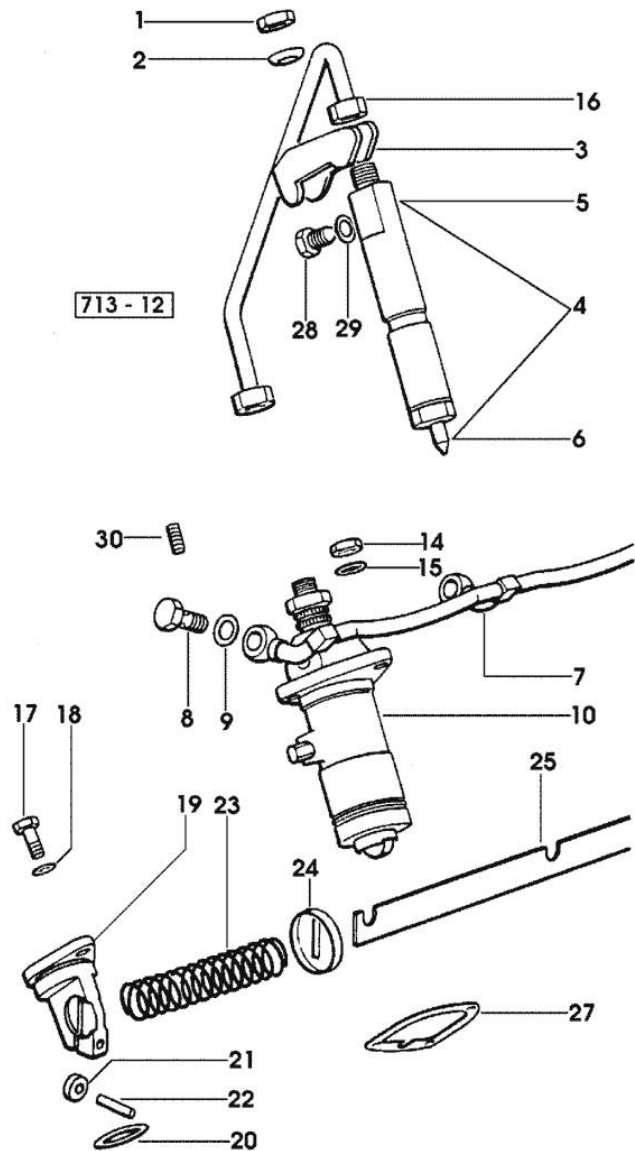

Fig.	P/n	QTY	Name
<b>Notes:</b>			
[EXPLORER 70 Special -> 15500]			
1	2.1011.421.2	4	nut m 10 p.1.25
2	2.1599.454.0	4	shoulder ring 10.5x17x7.5
3	0.011.5275.0/20	4	bracket
4	2.4719.200.0/10	4	injector assembly BOSCH
4	2.4719.320.0/10	4	injector assembly BOSCH - EXPORT U.S.A.
5	2.4719.190.0	4	nozzle holder BOSCH ☞ 2.4719.190.0 ☞ 01.00.48
6	2.4729.100.0	4	nozzle BOSCH
6	2.4729.170.0/10	4	nozzle BOSCH - EXPORT U.S.A.
7	0.077.1650.3/10	1	tube
8	2.3339.001.2	4	pipe union m 10 p.1x27
9	2.1560.005.0	8	copper gasket 10.2 x 14
10	2.4619.030.0/10	4	injector pump - 555 - BOSCH - EXPORT U.S.A. ☞ 2.4619.030.0/10 ☞ 01.00.59
10	2.4619.050.0/30	4	injector pump - 542 - BOSCH F 17 - 17/1 ☞ 2.4619.050.0/30 ☞ 01.00.59
14	2.1011.405.2	12	nut m 8 p.1
15	2.1599.458.0/10	12	shoulder ring 8.4x18x2
16	0.065.1650.3	4	tube
17	2.0112.207.2	2	screw m 8 p 1.25 x 20
18	2.1310.004.2	2	flat washer 8.4x17
19	0.065.1693.0/20	2	support
20	2.1530.072.0	2	oil seal 26.70x1.78
21	0.065.1660.0	2	roller
22	2.1652.507.0	2	pin 6x16
23	2.4019.314.1/20	1	spring 21.5x76x1
24	0.065.1659.0	1	stop
25	0.065.1613.3/20	1	rod
27	0.065.1655.0/10	4	shim mm 0.1
27	0.065.1656.0/10	16	shim mm 0.20
28	2.3119.024.2	4	plug m 6
29	2.1560.001.0	4	gasket 6.2x10
30	2.0512.102.7	4	screw m 6 p.1 x 8

(...) <-

Thank you so much for reading.  
Please click the “Buy Now!”  
button below to download the  
complete manual.



After you pay.

You can download the most  
perfect and complete manual in  
the world immediately.

Our support email:

[ebooklibonline@outlook.com](mailto:ebooklibonline@outlook.com)